



**MODEL EF  
Full Circle  
Tire Spreader**

Installation, Operation  
& Repair Parts  
Information

---



## **CAUTION**

- ◆ **Before using this product, read and fully understand the operating instructions and all decals on the product. This is necessary to prevent injury to the operator and damage to the product.**
- ◆ **This product is intended to be used to spread tire casings for inspection and/or repair only.**
- ◆ **Keep fingers and hands clear of all hooks and mechanisms during operation.**
- ◆ **Do not use this product if it is visibly worn, distorted or damaged.**
- ◆ **Always wear appropriate eye protection.**

## **WARNING**

- ◆ **Keep feet clear of the tire lift when raising and lowering tire.**
- ◆ **All personnel must be clear of the spread arms during operation.**

## **INSTALLATION**

- 1) Position the Model eF on a solid level floor leaving a minimum of 12 inches of clearance from rear and 24 inches of clearance from sides. The eF can be bolted down if desired using the four holes in bottom of frame.
- 2) Install the light post in socket on the top of cylinder housing and lock in place with set screw. Hang the light fixture assembly on the light post as shown on the cover of this manual. Lock in place with tee set screw. Cable tie the power cord to the light post and plug in to outlet on frame column.
- 3) Attach the loose spread arm spring to spread arm. Refer to the other spread arm for proper spring location.
- 4) Attach the lift cradle to the lower lift arms.
- 5) Install a 1/4 NPT quick coupler nipple (not provided) into the air filter located on frame column. Use 1/4 inch air hose with 100 p.s.i. minimum.

## **OPERATION**

- 1) Roll tire onto lift cradle, and while balancing the tire with hands, step on left foot valve to raise tire just above inner bead hooks. Release lift valve to allow cradle to lower to floor and tire hanging on inner bead hooks.

- 2) While keeping tire on inner bead hooks, step on center foot valve to spread and fully engage all four hooks on inner bead of tire.
- 3) Grasp both outer bead hook arms by the handles and pull to center of tire. Push forward and allow bead hooks to engage outer bead of tire. **Make certain all hooks are securely engaged with tire beads before spreading tire.**
- 4) To spread the tire, step on right foot valve to obtain desired spread. Tire can now be rotated and inspected.

 **WARNING**

- ◆ **Do not release the inner bead hooks (center valve) until the outer bead hooks have been released (right valve) and removed from tire.**

- 5) To remove tire, release spread arm control valve (right valve) and remove outer bead hook.
- 6) Release pressure on inner bead hooks by stepping on diameter control valve (center valve).
- 7) With tire hanging on inner hooks, raise lift cradle (left valve) up to contact tire. While holding onto tire, raise tire slightly above inner bead hooks and lean tire outward and release pressure on lift valve to lower tire to floor.

## ***MAINTENANCE***

- MONTHLY** – Put a few ounces of 10 or 20 weight oil in all cylinders.  
Lubricate all moving parts (bolts, hinges, rollers, etc.) with a lubricating oil.  
Grease cylinder bearings through the grease zerk fittings. Apply some grease to the races of the bearings also.

## Repair Parts Information

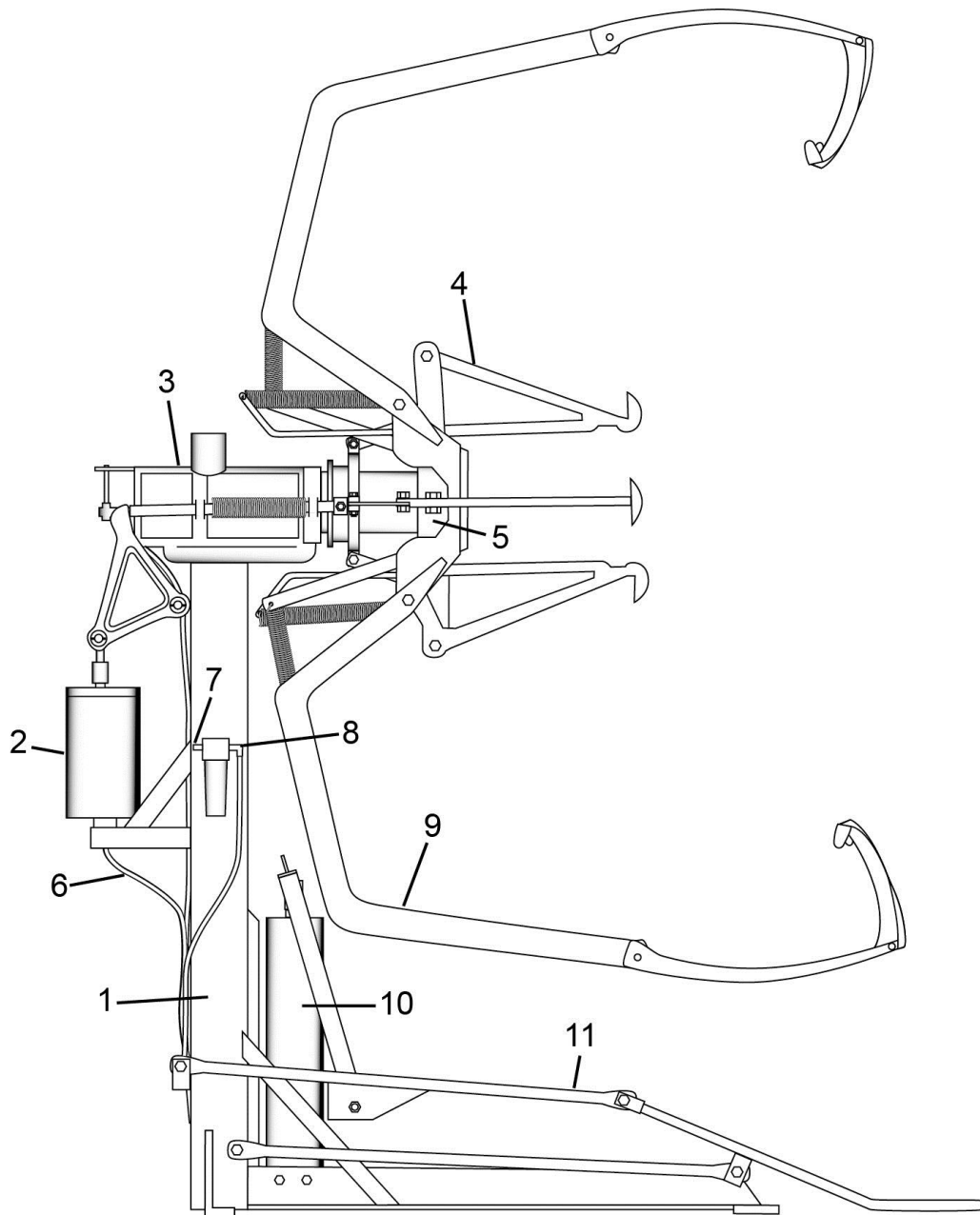

### MODEL EF GENERAL ASSEMBLY

ITEM	QTY	P/N	DESCRIPTION	PAGE
1	1	900-003	Base and Column	3
2	1	900-043	Diameter Arm Cylinder Assembly	5
3	1	900-009	Housing Assembly	4
4			Diameter Arm and Linkage	4
5	1	900-020	Spread Cylinder Assembly	5
6	1	D20-007	1/4" Air Line	3
7	1	096-170	1/4" Truflate Nipple	3
8	1	096-342	1/4" x 1/4" Male Elbow	3
9			Spread Arm Components	6
10	1	900-008	Lift Cylinder Assembly	7
11			Lift Cradle and Linkage	7
			Pneumatics	8

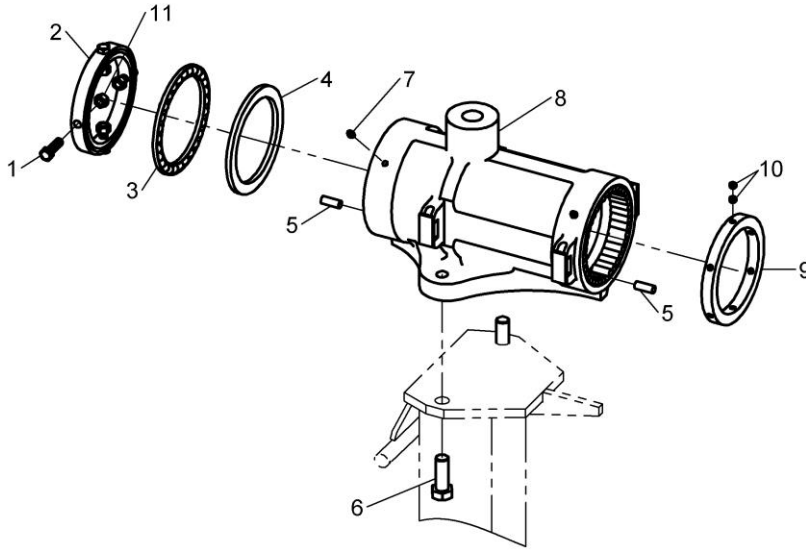

**900-009 Housing Assembly**

ITEM	QTY	P/N	DESCRIPTION	ITEM	QTY	P/N	DESCRIPTION
1	4	028-046	3/8" x 16 x 1 1/4" Hex Head Cap Screw	7	2	096-008	1/4" Grease Zerk
2	1	107-001	Rear Collar Ball Race	8	1	950-027	Housing
3	1	107-004	Ball Thrust Bearing	9	1	107-003	Front Collar
4	1	107-002	Inner Ball Race	10	12	028-004	5/16" x 1/4" Socket Set Screw
5	80	281-001	Bearing Roller	11	4	055-210	3/8" Hex Locknut
6	2	028-016	5/8" x 1 3/4" Hex Head Cap Screw				

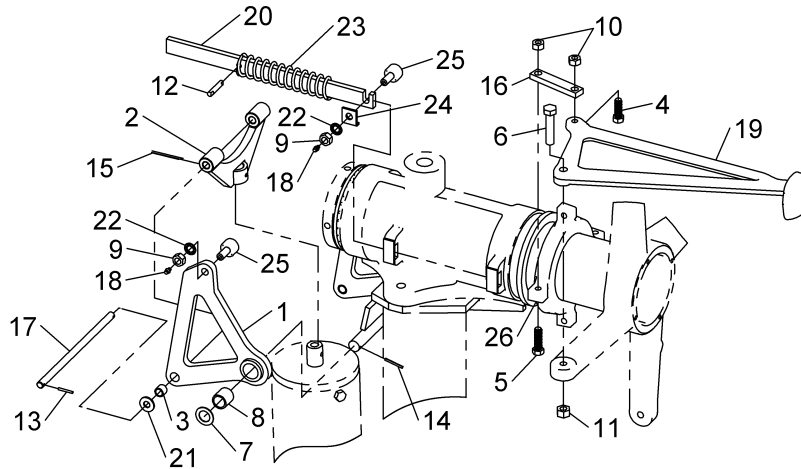

**Diameter Arms and Linkage**

ITEM	QTY	P/N	DESCRIPTION	ITEM	QTY	P/N	DESCRIPTION
1	2	03-0635	Bell Crank	14	2	061-006	1/8" X 1-1/4" Spring Pin
2	1	267-001	Diameter Cylinder Connector	15	1	061-166	Cotter Pin
3	2	20-0055	7/16" Sleeve Bearing	16	4	062-001	Diameter Arm Connecting Link
4	4	028-007	7/16" X 1-1/4" Hex Head Screw	17	1	73-1141	Pivot Shaft
5	4	028-008	7/16" X 1-1/2" Hex Head Screw	18	4	096-010	3/16" Grease Zerk
6	4	028-023	1/2" X 2-1/4" Hex Head Screw	19	4	103-007	Diameter Arm
7	2	039-002	3/4" Machine Bushing	20	2	104-003	Slide Bar
8	2	039-043	3/4" Sleeve Bearing	21	2	108-126	3/8" Washer
9	4	51-0057	7/16" - 20 Nut	22	4	108-038	7/16" Internal Tooth Washer
10	8	055-058	7/16" - 14 Bi-Way Lock Nut	23	2	110-002	Slide Bar Spring
11	4	055-021	1/2" - 13 Bi-Way Lock Nut	24	2	111-024	Arm Bracket
12	2	061-004	Slide Bar Pin	25	4	281-002	Cam Roller
13	2	061-005	1/8" X 1" Spring Pin	26	1	489-001	Sliding Collar

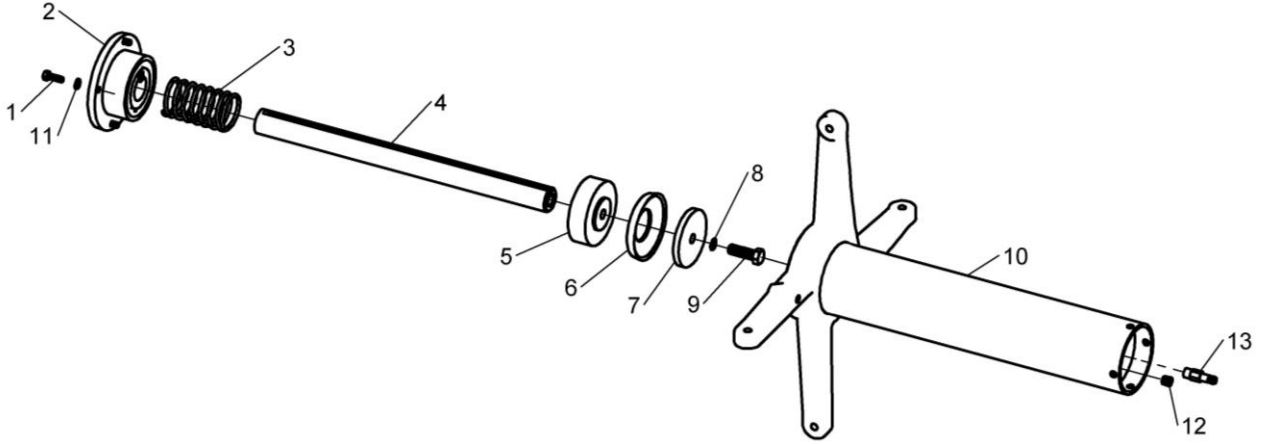

**900-020 Spread Cylinder Assembly**

ITEM	QTY	P/N	DESCRIPTION	ITEM	QTY	P/N	DESCRIPTION
1	4	028-014	5/16" x 1" Hex Head Cap Screw	8	1	167-240	14 mm Gasket
2	1	950-029	Cover Plate	9	1	028-013	9/16" x 1 3/4" Hex Head Cap Screw
3	1	110-003	Spring	10	1	950-023	Spread Arm Cylinder
4	1	149-005	Piston Rod	11	4	108-067	5/16" Shakeproof Washer
5	1	051-005	4" Diameter Spread Piston	12	1	096-004	1/4" Oil Plug
6	1	041-007	Piston Cup	13	1	096-170	1/4" Trueflate Nipple
7	1	108-010	Piston Cup Follower			643-135	1.038 Rotary Union Kit

\* Items not included in 900-020 Spread Cylinder Assembly

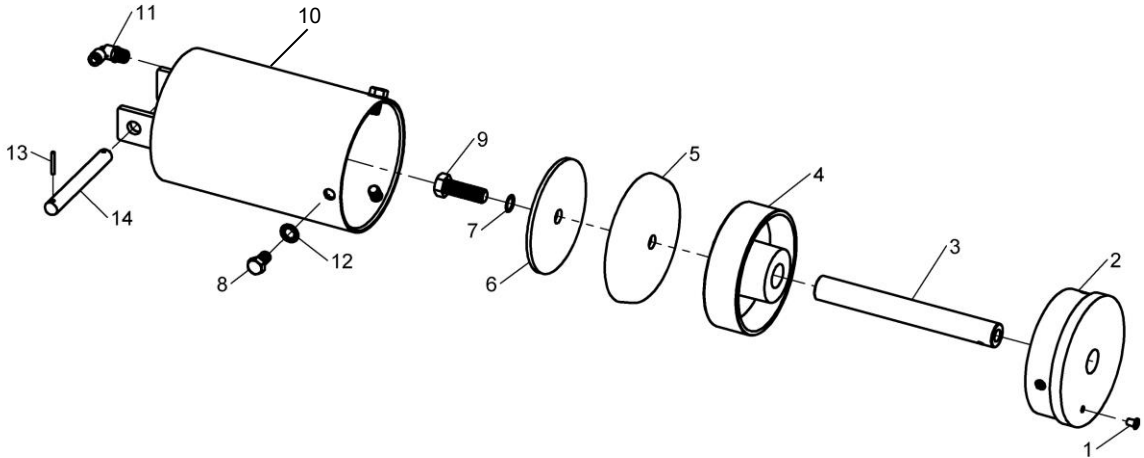

**900-043 Diameter Arm Cylinder Assembly**

ITEM	QTY	P/N	DESCRIPTION	ITEM	QTY	P/N	DESCRIPTION
1	1	006-004	#1 Cap Plug	8	3	028-005	7/16" x 3/4" Hex Head Cap Screw
2	1	264-001	Cylinder Head	9	1	028-013	9/16" x 1 3/4" Hex Head Cap Screw
3	1	104-002	Piston Rod	10	1	950-064	Diameter Arm Cylinder
4	1	051-016	5 1/4" Diameter Piston	11	1	096-342	1/4" x 1 1/4" Male Elbow
5	1	041-009	Piston Cup	12	3	108-038	7/16" Shakeproof Washer
6	1	101-033	Piston Cup Follower Plate	13	2	061-005	1/8" x 1" Drive Pin
7	1	167-240	14 mm Gasket	14	1	149-020	Diameter Cylinder Pin

\* Items not included in 900-043 Diameter Arm Cylinder Assembly

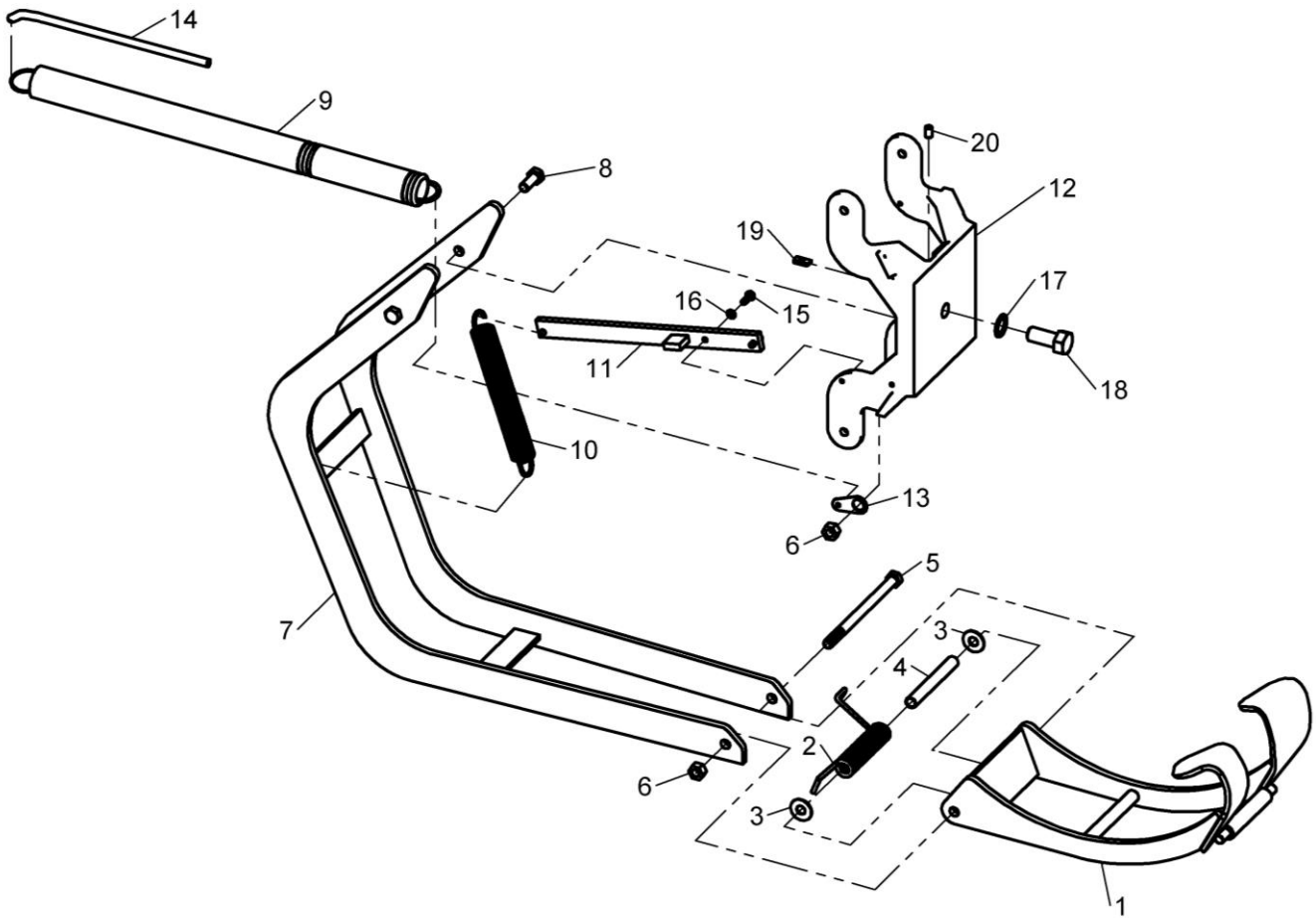

### Spread Arm Components

ITEM	QTY	P/N	DESCRIPTION	ITEM	QTY	P/N	DESCRIPTION
1	1*	950-020	Bead Hook	11	1*	950-017	Spring Bar
2	1*	110-006	Bead Hook Spring	12	1	264-002	Extension Head
3	2*	108-144	1/2" Fiber Washer	13	1*	017-005	Return Spring Clip
4	1*	446-004	Spring Sleeve	14	1*	149-015	Return Spring Rod
5	1*	242-003	1/2" x 7 1/2" Machine Bolt	15	2*	028-010	1/4" x 3/4" Hex Head Cap Screw
6	3*	055-058	1/2" Hex Head Lock Nut	16	2*	108-008	1/4" Shakeproof Washer
7	1*	900-018	Spread Arm	17	1	108-007	3/4" Shakeproof Washer
8	2*	028-034	1/2" x 1 1/4" Hex Head Cap Screw	18	1	028-009	3/4" x 1 3/4" Hex Head Cap Screw
9	1*	110-004	Extension Head Return Spring	19	1	101-019	3/16" x 3/8" x 7/8" Detent Plate
10	1*	110-005	Spread Arm Spring	20	1	028-223	3/8" x 5/8" Socket Set Screw

\* Quantity shown for these parts is for one (1) spread arm. If servicing both spread arms double quantities.

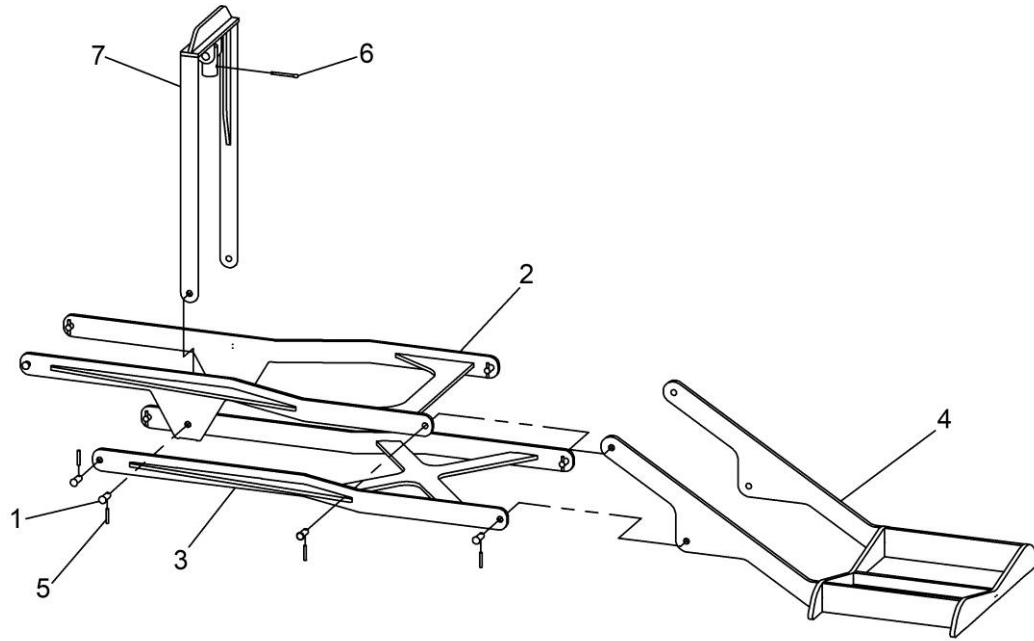

### Lift Cradle and Linkage

ITEM	QTY	P/N	DESCRIPTION	ITEM	QTY	P/N	DESCRIPTION
1	10	003-001	Flat Head Rivet	5	10	061-009	Spring Pin
2	1	03-0649	Upper Cradle Arm	6	1	061-013	5/32 x 1.75 Cotter
3	1	03-0650	Lower Cradle Arm	7	1	950-011	Yoke Assembly
4	1	03-0651	Tire Cradle				

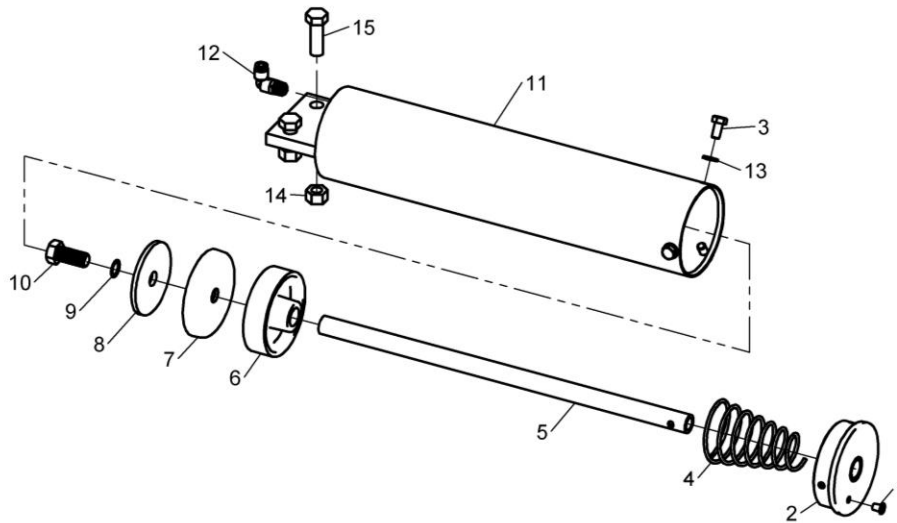

### 900-008 Lift Cylinder Assembly

ITEM	QTY	P/N	DESCRIPTION	ITEM	QTY	P/N	DESCRIPTION
1	1	006-004	#1 Cap Plug	9	1	167-240	14 mm Gasket
2	1	925-003	Cylinder End Cap with Bushing	10	1	028-239	9/16" x 1 1/4" Hex Head Cap Screw
3	3	028-002	5/16" x 5/8" Hex Head Cap Screw	11	1	950-013	Lift Cylinder
4	1	110-007	Lift Cylinder Spring	12	1	096-342	1/4" x 1/4" Male Elbow
5	1	149-003	Piston Rod	13	1	D20-007	1/4" x 60" Impolene Air Line
6	1	051-023	3 1/2" Diameter Lift Piston	14	2	055-058	1/2" Hex Head Lock Nut
7	1	041-015	Piston Cup	15	2	028-025	1/2" x 1 1/2" Hex Head Cap Screw
8	1	108-032	Piston Cup Washer				

\* Items not included in 900-008 Lift Cylinder Assembly



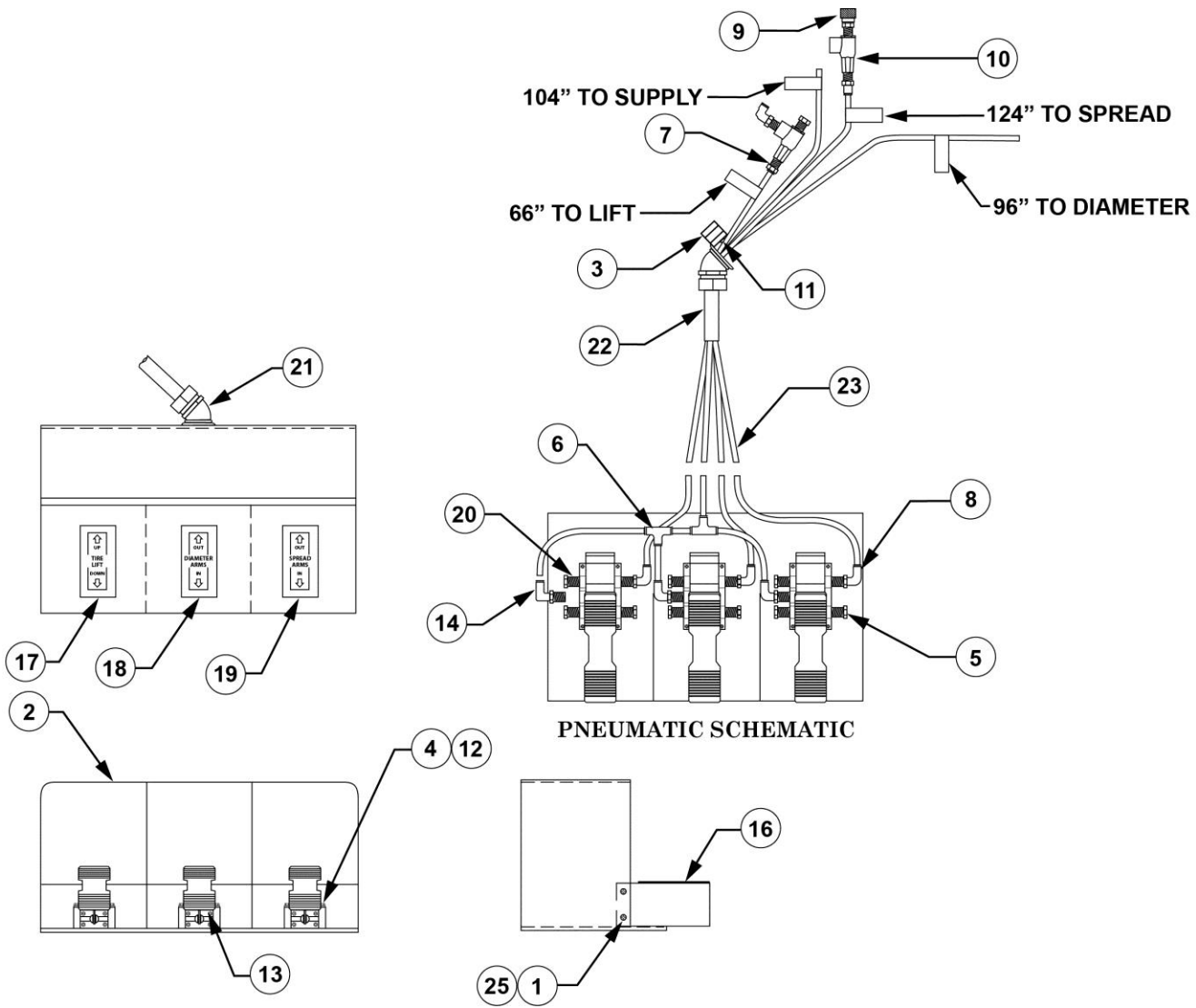

**05-0009 PNEUMATICS ASSEMBLY**

ITEM	QTY	P/N	DESCRIPTION
1	4	50-0090	#8-32 X 3/8" Tapping Screw
2	1	03-0048	Foot Valve Guard Weldment
3	1	03-0052	Fitting Mount Weldment
4	12	055-082	#8-32 Nylon Lock Nut
5	6	096-004	1/4" NPT Hex Plug
6	2	096-339	1/4" Tube Union Tee
7	1	096-340	1/4" NPT Male Fitting
8	7	096-342	1/4" Male Elbow
9	1	60-0149	1/4" Male Quick Coupler
10	2	190-085	Quick Exhaust Valve
11	1	50-0006	5/16-18 x 3/8" Set Screw
12	12	50-0041	#8-32 x 1" Flat Head Machine Screw
13	3	60-0009	Treadle Valve
14	1	60-0010	1/4" NPT Swivel x 1/4" Tube Elbow
15	1	72-0021	Airline Guard
16	1	80-0031	Tire Lift Decal
17	1	80-0032	Diameter Arms Decal
18	1	80-0033	Spread Arms Decal
19	5	885-035	Valve Muffler
20	2	980-085	3/4" x 45" Conduit
21	1	B40-003	3/4" Flex Conduit
22	400"	D20-007	1/4" OD Plastic Tube
23	4	52-0006	Internal Tooth Star Washer