



# 12,000 lb Square Jack

## Read, Understand, Follow and Save These Instructions

- Read, understand and follow all instructions before installing and using this product. Never allow anyone unfamiliar with the operating instructions to use this product.
- Read, understand and follow all instructions provided by the manufacturer of the product(s) that this product will be installed on.
- Installation of this product must conform to the following mounting instructions only.
- Save these instructions for use as a reference in the future.



## WARNING

**Failure to follow these warnings and instructions may result in property damage, serious bodily injury, and/or death.**

- Purchaser/owner must ensure that product is installed according to these instructions. Purchaser/owner must not alter or modify product.
- Operator and bystanders should never position any part of body under any portion of this product or the load being supported.
- Fully retract and/or rotate jack before towing.
- When using the drop leg, make certain the drop leg pin is fully inserted before using the jack.
- Do not allow children to play on or around this product or the load being supported.
- Secure the load, vehicle and trailer from rolling (by blocking wheels) when operating jack or coupling trailer.
- Jack capacity is limited to the lesser of the jack, footplate, or caster wheel capacity.
- These jacks are designed for vertical loading. Excessive side forces may cause jack failure and must be avoided.
- If this product has a pivot tube mount, make certain the pivot pin is fully inserted through both sides on the pivot tube and the pivot mount.
- If this product has a drop leg, never attempt to adjust the drop leg when the jack is under load.
- These jacks are designed for mounting to flat surfaces only.
- Keep clear of pinch point at drop leg pin. The drop leg will naturally drop or retract very quickly depending on model.
- Keep clear of holes in drop leg.
- All welding must be performed by an AWS certified welder.
- Always replace bent, broken, or worn parts before using this product.

## Installation Instructions

**Warning: Failure to follow these warnings and instructions may result in property damage, serious bodily injury, and/or death.**

Before mounting the jack confirm that there will be no interference from the tow vehicle, tongue, ground, and any other mounted accessories while stationary or in motion. Before installing, check for interference in all positions including handle swing (in both gears, if applicable) and swivel positions if applicable. Check for interference again after installation is complete.

### Direct Mount to Load-Bearing Member:

- 1) All welding must be performed by an AWS certified welder.
- 2) Three 2" long 1/4" fillet welds must be placed on both sides of the jack along the contacting surface. The welds should be as far apart as possible to maximize strength under load.
- 3) If mounting in a tandem application, align the jacks carefully so they raise and lower together and share the load equally.

### 2-Speed Shift Pattern:

The jack handle moves 5/8"-3/4" while shifting. This clearance must be accounted for during installation.

- High gear is engaged when the shaft is pushed in.
- Low gear is engaged when the shaft is pulled out.

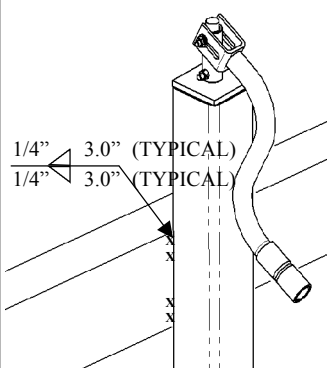
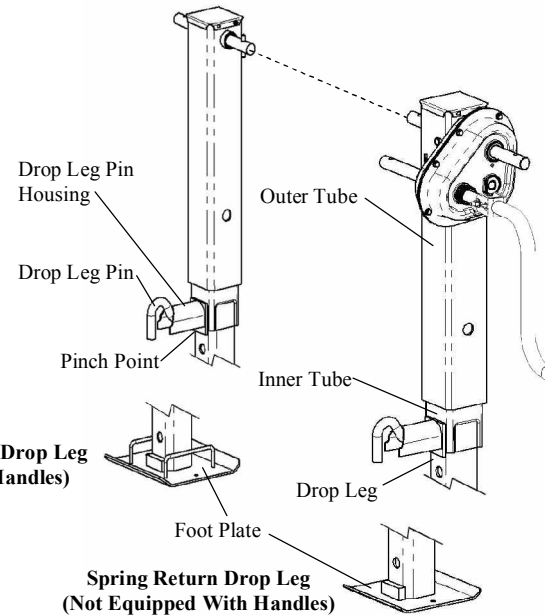
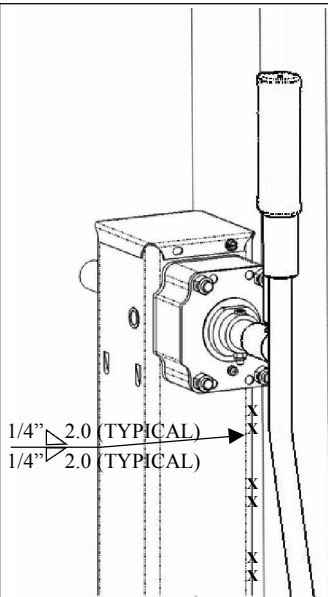

### Direct-Mount:

- 1) All welding must be performed by an AWS certified welder.
- 2) Place the jack at the desired location. Weld 3" in 2 locations on both sides of the jack using a 1/4" fillet

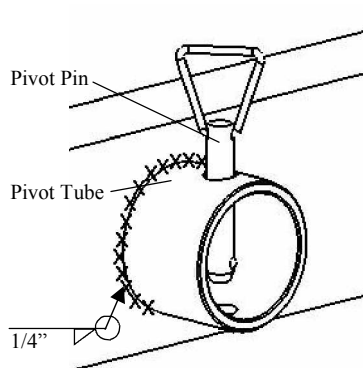

### Weld-on Pivot Tube Mounting Instructions:

- 1) All welding must be performed by an AWS certified welder.
- 2) The non-beveled side of the pivot tube is welded to the tongue.
- 3) Place the weld-on pivot tube against the tongue and weld all around with a 1/4" fillet weld. Align one set of pivot mount holes vertically.
- 4) Mate the jack to the pivot tube and secure with the supplied pin.

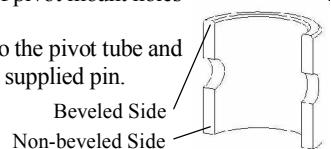

## Drop Leg Operation

### Spring Return Drop Leg Operation:

**WARNING:** Drop leg will naturally retract very quickly.  
1) Verify that the jack is not supporting any load.

- 2) If extended, place your foot on foot plate to control the return of the drop leg.
- 3) Disengage drop leg pin by rotating to the disengaged position.
- 4) Carefully move the drop leg to the desired position using your foot.
- 5) Engage drop leg pin by rotating it to the engaged position and into the desired adjustment hole.
- 6) Verify that the drop leg pin is fully inserted into the jack by checking for no clearance between the drop leg pin and housing. If you see clearance, you must adjust the drop leg to fully seat the pin into the hole location. You may need to lubricate the drop leg pin assembly as described in the maintenance section. If you are unable to fully seat the pin DO NOT USE.

### Non-Spring Return Drop Leg Operation:

**WARNING:** Drop leg will naturally fall.

- 1) Verify that the jack is not supporting any load.
- 2) If Retracted, grasp the handle of foot plate to control the fall of the drop leg.
- 3) Disengage drop leg pin by rotating to the disengaged position.
- 4) Carefully move the drop leg to the desired position.
- 5) Engage drop leg pin by rotating to the engaged position and into the desired adjustment hole.
- 6) Verify that the drop leg pin is fully inserted into the jack by checking for no clearance between the drop leg pin and housing. If you see clearance, you must adjust the drop leg to fully seat the pin into the hole location. You may need to lubricate the drop leg pin assembly as described in the maintenance section. If you are unable to fully seat the pin DO NOT USE.

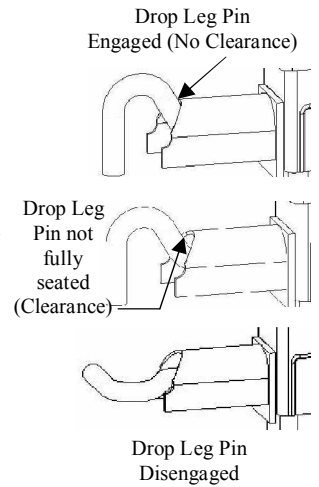

## Maintenance

The following procedures should be performed at least annually:

The gears, bushings, and screw of the jack must be kept lubricated. For side-wind models, apply a small amount of automotive grease with a grease gun at the lubrication points found on the side of the jack near the input shaft. Rotate the jack handle to distribute the grease evenly. A lightweight oil must be applied to the input shaft bushings at both sides of the jack or gearbox. For top-wind models, the screw-stem should be lubricated with a light-weight oil. If equipped, the drop leg pin and spring must be kept clean and lubricated with a lightweight oil.

