

# <THESE INSTRUCTIONS MUST BE GIVEN TO THE END USER>

## B&W Trailer Hitches



### Turnoverball® Gooseneck Hitch Installation Instructions

# MODEL 1019

2019 CHEVROLET/GMC 1500 Crew Cab Short Box (5'8")  
Excludes 2019 Chevy LD & GMC Limited.

Mounting Kit Box (GNRM1019)		
ITEM	DESCRIPTION	QTY
1	Driver Side Plate	1
2	Passenger Side Plate	1
3	Rear Cross Member	1
4	Front Cross Member	1
5	1/2" X 5-1/2" X 4-1/4" U-Bolt	2
	Fish Wire	2

Mounting Kit Bolt Bag		
ITEM	DESCRIPTION	QTY
6	1/2" Retainer	2
7	1/2" Frame Bushing	2
8	1/2" Locking Strap	2
	1/2" X 1-1/2" Carriage Bolt	2
	1/2" X 1-1/2" Cap Screw	12
	1/2" Finish Nut	12
	1/2" Lock Washer	18
	1/2" Flat Washer	14
	O-Ring	1

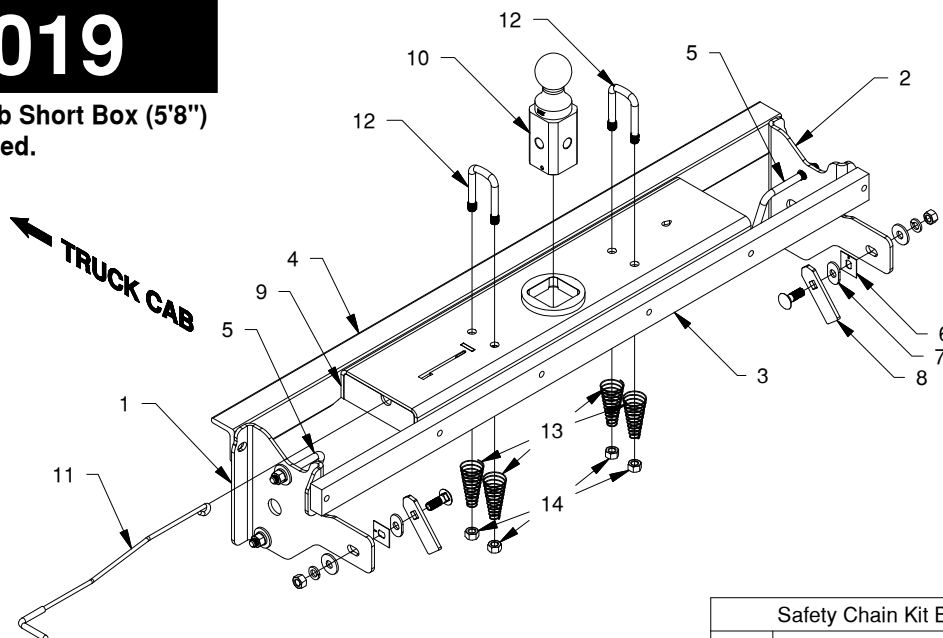

Center Box (GNRC919)		
ITEM	DESCRIPTION	QTY
9	Center Section	1
10	2-5/16" Ball	1
11	Latch Pin Handle	1

Safety Chain Kit Bolt Bag		
ITEM	DESCRIPTION	QTY
12	1/2" U-Bolt	2
13	Conical Springs	4
14	1/2" Lock Nut	4
	5/16" X 3/4" Carriage Bolt	1
	5/16" X 3/4" Cap Screw	1
	5/16" Lock Nut	1

## ⚠️ WARNING

Failure to comply with the safety information in these instructions could result in serious injury or death.

- ⚠️ Read all installation and operating instructions along with all labels before using this product.
- ⚠️ Adding components such as a Turnoverball hitch to the chassis of any vehicle can be hazardous. There is potential for unexpected combustion of fuel, electric shock, burns, shifting or falling of unstable vehicle, damage to vehicle, injury from tool usage and many other hazards. This installation must be completed by someone who is aware of the hazards involved. This person must be knowledgeable of proper safety procedures for a vehicle modification of this nature, and for usage of the equipment required to perform the installation.
- ⚠️ Without proper knowledge, towing can be a dangerous activity. Understand all the risks involved with towing before proceeding. For information on towing safety, see **"The Trailer Handbook: A Guide to Understanding Trailer and Towing Safety"** from the National Association of Trailer Manufacturers.
- ⚠️ Do not exceed tow or tongue rating of coupler, tow or tongue rating of hitch, or tow or weight ratings of truck or trailer. See vehicle and trailer manufacturer information for ratings. Exceeding these ratings may cause damage to towing components or loss of attachment between the trailer and truck.
- ⚠️ Additional caution must be used when towing a wedge car trailer. Towing stability greatly depends on keeping the center of gravity as low as possible. Load heavy cars over the axles. Never tow with a single car on the front of the trailer. When towing a wedge car trailer, never exceed speeds that are reasonable for the roadway conditions (e.g. turns, going around a curve, etc.). Failure to account for proper trailer center of gravity and speeds that are reasonable for the roadway conditions may cause damage to the truck, trailer, towing components, and loss of attachment between the truck and trailer.
- ⚠️ This product was designed to fit vehicles in their original, "as manufactured" condition. Compatibility with vehicles having replacement parts, or other modifications is not guaranteed. Inspect vehicle for modifications before installation of this product.
- ⚠️ The Turnoverball hitch comes equipped with a 2-5/16" ball. Trailers towed with the ball provided must have a 2-5/16" coupler. Towing with a larger coupler could cause loss of attachment between the trailer and the tow vehicle.
- ⚠️ Do not modify this product in any manner. Doing so could alter its integrity and lead to a loss of attachment between the trailer and the tow vehicle.

# PREPARE TO INSTALL

**NOTE:** Remove all parts from the packaging and familiarize yourself with all the parts and tools required. Use the parts list on the front page to verify that all parts and hardware are present.

Installation of the Turnoverball hitch requires several common tools and a few specialized tools. Below is a listing of equipment used during a typical installation.

## TOOLS REQUIRED

- Impact wrench or ratchet with 3/4", 10mm, & 13mm sockets.
- 1/2" & 3/4" Box end wrenches
- Marking tool ( pencil or permanent marker)
- 4" hole saw
- Drill with 1/2" bit
- Ear protection
- Pry Bar
- Lifting Device
- Screw driver with T15 and T25 bits.
- Flashlight
- Eye protection
- Torque wrench
- Tape measure
- Pilot hole Bit

1. **Determine cab clearance.** The Turnoverball hitch is designed so that the ball can be inverted and stored below the surface of the truck bed while not in use. The ball location is determined by this design feature and the truck geometry. Measure the trailers to be towed with this hitch to be sure that the location of the 2-5/16" ball listed in Step 11 will provide ample turning clearance between the nose of the trailers and the cab of the truck.

**⚠ Cab clearance on short bed trucks is very limited when towing certain trailers. Failure to ensure that there will be adequate clearance, may result in significant property damage, or serious injury.**

2. **Position the vehicle.** Installation of the hitch requires the installer to be under the truck bed in the area of the rear axle. Lifting the vehicle makes this area more accessible to the installer, and improves the installation process.

**⚠ WARNING: Lift vehicle using only equipment designed for lifting and positioning vehicles for service. Failure to do so may result in property damage, serious injury, or death.**

3. **Remove the spare tire.** Following the vehicle manufacturer's instructions, remove the spare tire.
4. **Remove the spare tire heat shield.** Remove the six bolts attaching the spare tire heat shield to the frame of the truck with a 13mm socket or wrench. Set the heat shield aside for later re-installation.
5. **Prepare a lifting device (optional).** The purpose of the device is to safely hold the hitch in position during part of the installation. See Figure A1 for an example.

A simple mechanical lifting device is available for purchase from B&W.

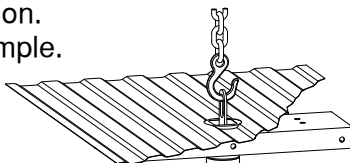

Figure A1.

6. **Remove and discard the heat shield above the rear axle.** A section of the exhaust heat shield will need to be removed. Locate the bed cross member that is directly over the axle, see Figure A2. The section of heat shield in front of this cross member will have to be removed. Cut along the cross member with tin snips or another suitable tool. Make sure that none of the heat shield is protruding past the front of the cross member. Remove the T25 Torx screws holding the front of the heat shield to the truck. Discard the forward section of the heat shield when it has been removed.

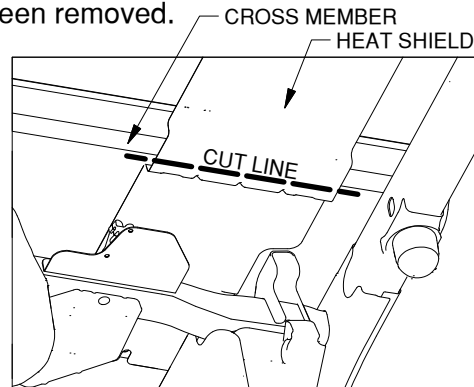

Figure A2: View looking up at bottom of bed above axle.

7. **Lower the exhaust (Optional).** To ease in the installation of the center section, un-attach the rear most tail pipe hangers from the frame and allow the exhaust to hang freely. Re-attach the exhaust brackets after installation is complete.
8. **Un-attach brake and wiring brackets.** Two brackets are attached to the frame in locations that will interfere with the installation. Using a 10mm socket or wrench un-attach these brackets and allow to hang during installation. These brackets will be re-attached when the installation is complete. The first bracket holds two brake lines on the inside of the driver side frame just behind the rear axle, see Figure A3. The second bracket holds wiring and is attached to a rectangular frame cross member in front of and above the differential. Loosen the connection and slide the bracket to the driver side and unhook from frame. Allow to hang, see Figure A4.

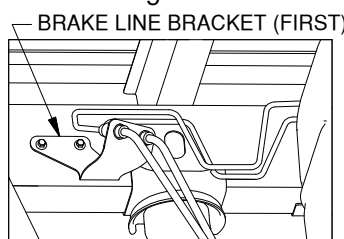

Figure A3.

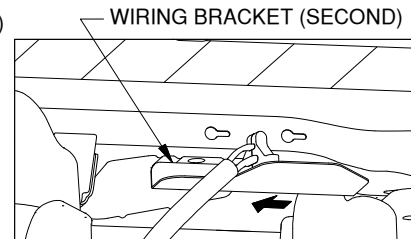

Figure A4.

9. **Disconnect wiring harness.** Locate the wiring harness running along the top of the passenger side frame rail above the rear axle. Detach the plastic connector closest to the shock bracket from the frame. Pull the wiring down off the top of the frame, towards the inside, to make space for the forward cross member to sit on top of the frame. This wiring will be left loose during and after the installation.

10. **Un-attach the wheel well liners.** Check for the presence of flexible wheel well liners in the truck wheel wells. If present, two T15 Torx screws will need to be removed so that the liners can be folded up and allow the cross members and side plates to be installed, see Figure A5. Remove the screw retainer from forward most hole using a screw driver. It will be replaced after the hitch is installed.

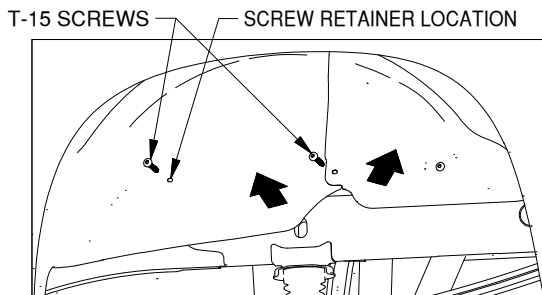

Figure A5: View looking into driver side wheel well.

11. **Mark the 4" hole location.** Using a tape measure hooked over the rear edge of the bed (at tailgate end), measure the location for the hole as shown in Figure A6. Next, locate the center of the bed by measuring the distance between the wheel wells and dividing by two. The center of the hole will be at the intersection of the center of the bed and the first distance measured.

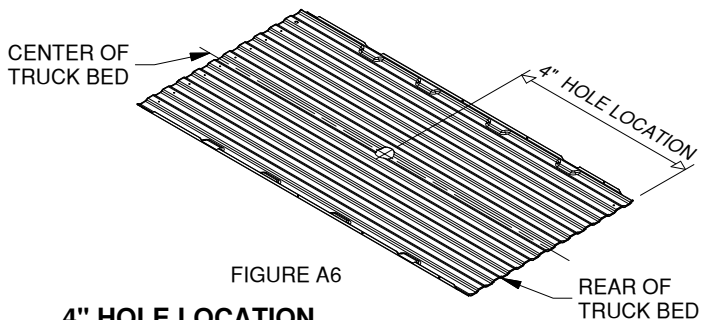

FIGURE A6

#### 4" HOLE LOCATION

#### SHORT BED (5'8") - 44 1/8"

**IMPORTANT:** The hitch is designed to install only at the described location. Failure to place the 4" hole precisely may result in added difficulty during installation or property damage.

**IMPORTANT:** If the bed is equipped with a plastic bed liner, the hole may be cut through both the liner and the bed. However, the center of truck bed may be more difficult to locate, and the mark may be harder to hit if the liner slides or moves. Failure to cut the hole in the correct location may adversely affect the install and may result in property damage.

**IMPORTANT:** If your truck has a spray-in bed liner you will need to take this into account when you are measuring, and add the thickness of the applied liner that has been sprayed over the end of the bed.

12. **Cut the 4" diameter hole.** Cut the hole in the marked location using a 4" hole saw or by marking out the 4" hole and using a saber saw equipped with a metal cutting blade. Remove any burrs created while cutting hole.

**⚠ Turnoverball hitch components are heavy and may be cumbersome to handle. Failure to use proper lifting techniques and caution when handling these items could result in serious injury.**

**⚠ Most trucks have fuel lines, brake lines, electrical wires or other vehicle systems located along the frame rails or in the general area where B&W Turnoverball hitches install. Carefully examine the locations of these systems before installation. Make certain that these are not damaged during positioning hitch components, drilling holes, or tightening fasteners. Damage to these systems may result in property damage, serious injury, or death.**

## INSTALL CROSS MEMBERS AND CENTER SECTION

1. **Install front cross member.** Starting in the driver side wheel well, orient the front cross member (angle iron) so that the heel of the angle is up and the flange with the holes is towards the back of the truck, see Figure B1. Pass the cross member between the bed and the frame until it rests on the passenger side frame. Roll the cross member so that the flange with the holes is vertical. Install a 1/2" X 1-1/2" cap screw into the second hole from the driver side of the cross member with the threads towards the back of the truck. Install the rubber O-Ring onto this bolt to keep it in place during installation, See Figure B2. Push the passenger side of cross member forward until it hits the shock bracket. Push the driver side of the cross member forward to make extra room for the center section to be installed.

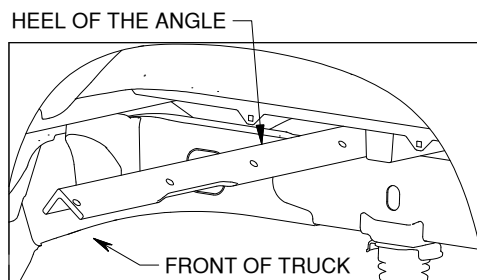

Figure B1: View looking into wheel well.

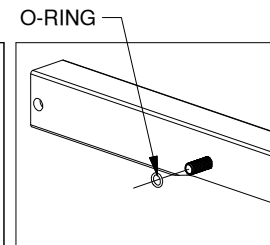

Figure B2.

*Continued on next page...*

2. **Install center section.** Starting behind the differential under the truck, hold the center section so that the top of the center section is facing towards the back of the truck and the latch pin handle is on the driver side, see Figure B3. Position the center section over the differential and axle and move it towards the driver side between the frame and the axle. Move the center towards the driver side far enough that the passenger side of the center can be lifted up past the exhaust, see Figure B4. Roll and lift the center up towards the passenger side of the truck so that the top of the center is towards the bed and the passenger side of the center is over the exhaust. Lift the driver side of the center up and forward so that it is positioned over the fuel tank.

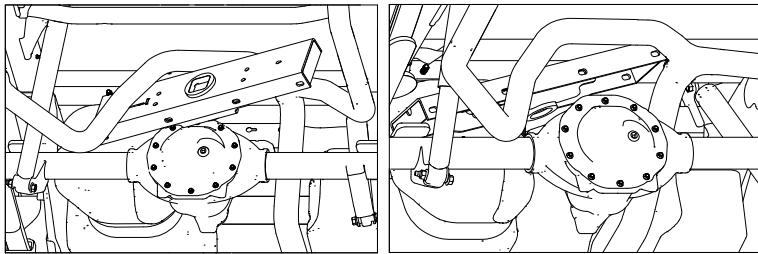

Figure B3: View looking up over axle.

Figure B4: View looking up over axle.

**CAUTION:** Plastic components located on top of the fuel tank can be easily damaged during the installation of the hitch components. Care must be taken when positioning the front crossmember and center section.

3. **Install rear cross member.** Starting in the driver side wheel well, orient the cross member so that the bar is vertical, and the threaded holes are closer to the top of the bar. Pass the cross member between the bed and the frame until it rests on the passenger side frame, see Figure B5. Center the cross members between the bed flanges on either side of the truck. Push the cross member back against the bed cross member to make room for the center section.

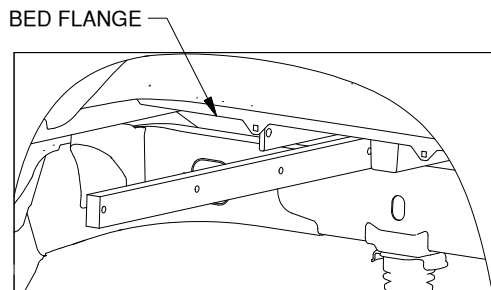

Figure B5: View looking into driver side wheel well.

4. **Attach the center to the cross members.** Lift the center section so that the raised portion on the top of the center is through the 4" hole drilled in the bed earlier. Secure with a lifting device if available. Slide the front cross member back against the center section so that the bolt installed previously in the front cross member goes into the center section slot directly across from it. Line up the rest of the holes and attach the two members with 1/2" x 1-1/2" long cap screws, flat washers, lock washers, and nuts. Insert four 1/2" x 1-1/2" bolts, with flat and lock washers installed, through the rear leg of the center section into the threaded holes of the rear cross member, see Figure B5. Leave these bolted connections loose, engaging only 3-4 threads, for the time being.

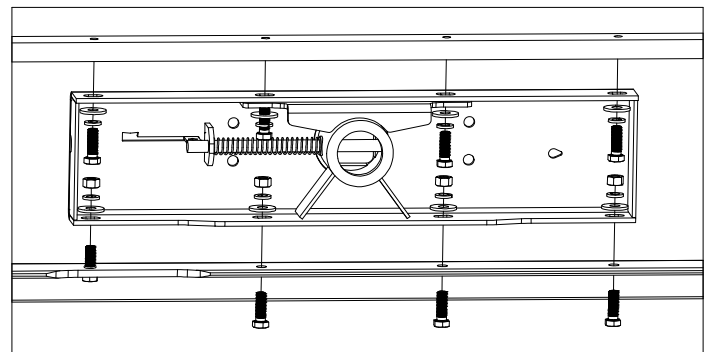

Figure B5: View looking under the truck bed.

## INSTALL SIDE PLATES

1. **Position the U-bolts.** Each side plate will utilize a U-bolt for attachment to the frame. On the driver side, the U-bolt will need to be passed under the brake lines on the side of the frame, see Figure C1. On the passenger side the U-bolt will need to be positioned under the wiring that runs over the top of the frame, see Figure C2. Move the U-bolts so that they hang roughly 8 inches in front of the axle center line.

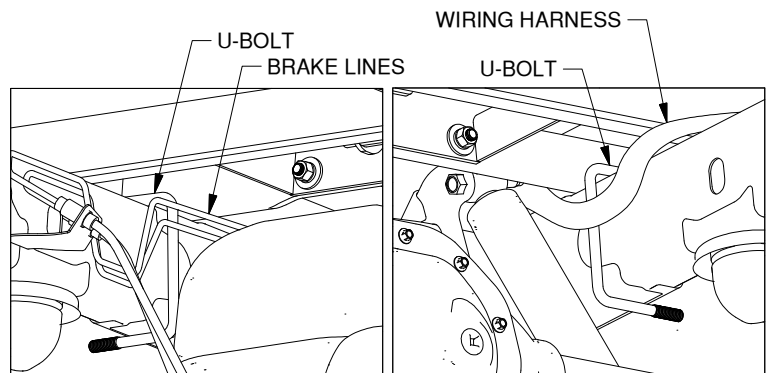

Figure C1:  
View looking at driver side of frame

Figure C2:  
View looking at passenger side of frame

*Continued on next page...*

- 2. Install frame studs.** Locate the oval hole on the outside of the frame directly over the center line of the axle. To begin, place a 1/2" x 1-1/2" carriage bolt through a locking strap. Next, thread a fish wire onto the end of the carriage bolt. From the inside of the frame pass the fish wire through the oval hole located earlier. While holding the fish wire on the outside of the frame push the locking strap and carriage bolt into the frame, see Figure C3. Continue pulling on the fish wire until the threaded portion of the bolt is sticking out of the frame. Turn the carriage bolt until the square shoulder engages the square hole of strap. Before removing the fish wire, thread the oval frame spacer on the carriage bolt and into the oval slot. Remove the fish wire and thread a bolt retainer on the carriage bolt to hold the bolt in place. Repeat this step on other side of the truck.

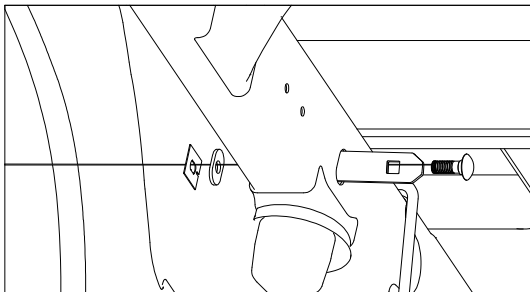

Figure C3: View looking at driver side frame.

- 3. Install the side plates.** Pass the side plates over the U-bolts and stud placed in the frame. Secure each side plate with flat washers, lock washers, and nuts, see Figure C4. Attach the front flange of the side plate to the front angle cross member by placing a 1/2" X 1-1/2" bolt through the front cross member, then secure to the side plate with a lock washer and nut. Next, attach the side plate to the rear bar by placing a 1/2" X 1-1/2" bolt with a lock washer through the side plate flange and threading it into the rear cross member, see Figure C5. Leave these bolted connections loose for the time being.

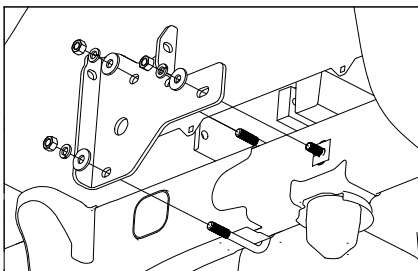

Figure C4: View looking is driver side wheel well.

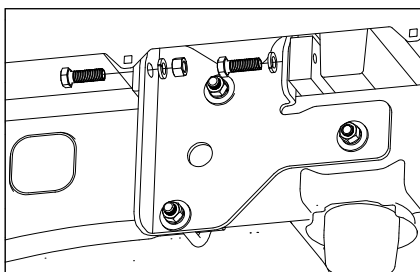

Figure C5.

## SECURE HITCH

- 1. Square the hitch.** Start by hand tightening each of the bolts attaching the center section to the cross members. Next, with a tape measure, check the distance between the Turnoverball hitch and the nearest bed cross member. The distance between the hitch and the cross member should be consistent on the driver side and the passenger side of the hitch, see Figure D1.

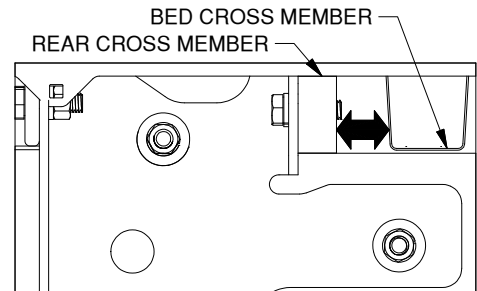

Figure D1: View looking at driver side plate.

**IMPORTANT:** The hitch must be square in the truck. If the center section is not parallel with the axle, certain accessories to the Turnoverball hitch will not be square with the truck.

- 2. Tighten the center section bolts.** Tighten each of the eight bolts attaching the center section to the cross members. Torque each bolt to 110 ft. lbs.
- 3. Tighten the side plate bolts.** With the hitch squared and firmly against the frame, tighten each of the bolted connections in the side plates until snug in this order: 1st, tighten the hardware attaching the side plates to the cross members. 2nd, tighten the nuts attaching the side plates to the frame studs installed inside the frame. 3rd, tighten the U-bolt nuts to the frame. Once all the hardware is snug, torque the bolts in the side plate ears 110 ft. lbs. Tighten the side plate frame stud connection to 110 ft. lbs. Tighten both side plate U-bolts alternating between the top and bottom threads so that the U-bolt is secured evenly. Torque nuts on U-bolts to 40 ft. lbs.

# INSTALL LATCH PIN RELEASE HANDLE

**IMPORTANT:** The latch pin will not function properly if handle is not installed correctly.

1. **Cut access hole though liners.** If truck is equipped with wheel well liners, an access hole needs to be cut in the liner. Draw a line on the liners, between the two holes of the screws that were removed. Drill a pilot hole on the line 8-3/4" forward of the rear hole. Make sure this pilot hole lines up with the latch pin mechanism on the center. Use a hole saw or other method to cut a 1" to 1.5" diameter hole in this location.
2. **Install handle.** Install the latch pin release handle by inserting it, from the outside of the truck, through the slot in the end of the center section on the driver side of the truck. Align the handle eyelet with the square hole in the latch pin so the handle is in line with the latch as shown in Figure E1.
3. **Secure Handle.** Secure the handle to the pin with the 5/16" X 3/4" carriage bolt and 5/16" locking flange, see Figure E2. Note: The included 5/16" cap screw can replace the carriage bolt if wrench access on the "cab side" of the handle is limited. Tighten the nut until it is secure. When tightening the handle, position it so that it will not rub on the center, the side plate, the bed flange, or the liner. Retract and release the handle slowly to make sure it will not hang up on any obstacles that may prevent the latch pin from fully engaging the socket. Do not over-tighten and deform the handle eyelet.

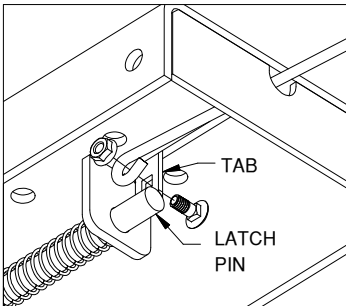

Figure E1.

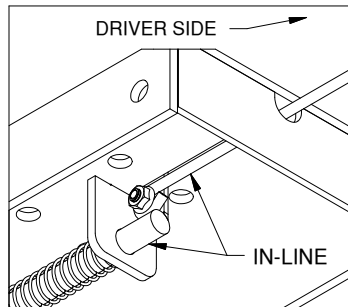

Figure E2.

# INSTALL SAFETY CHAIN U-BOLTS

1. **Drill the holes.** To install the safety chain brackets, it is necessary to drill four 1/2" holes through the truck bed floor. Drill the holes so that they match up with the two sets of holes on each side of the center. This may be done by drilling the 1/2" holes from the bottom using the center as a guide, or by drilling a smaller pilot hole from the bottom and drilling the 1/2" holes from the top side of the bed.
2. **Install the U-bolts.** From the top side of the truck bed, drop a U-bolt in each set of holes.
3. **Add Springs.** Place a conical spring over each leg of the U-bolts and secure with a 1/2" lock nut. see Figure F1. Tighten the lock nut until the nut is flush with the end of the U-bolt.

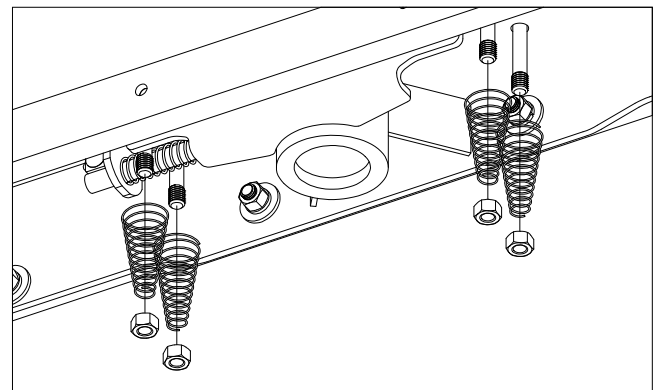

Figure F1: View looking up at center.

## PREPARE FOR TOWING

1. **Replace truck components.** Replace the wire bracket, brake line bracket, and spare tire heat shield which were removed in the PREPARE TO INSTALL section. If the exhaust was lowered re-attach the tail pipe hangers. If wheel well liners were present, re-install the T-15 Torx screws and screw retainer that were removed earlier.
2. **Replace spare tire** If the spare tire was removed prior to installing the hitch, replace it at this time.
3. **Retract the pin.** Pull the handle out all the way until it stops then slide it toward the cab. The handle should stay in this position. The latch should only be put in this open position when inverting the 2-5/16" ball or installing a B&W towing accessory.

**⚠ The handle operates in a very tight space within the wheel well of the truck. Use caution when operating the handle so that your hands and fingers do not get injured on the sharp edges of the truck, or by getting pinched against the frame due to the force of the spring loaded latch pin.**

**⚠ Operating the tow vehicle while the latch is in the open position may allow the handle to come into contact with the rear tire. This may damage the tire or the handle and could lead to serious injury or death.**

4. **Lubricate 2-5/16" ball.** Apply a light coating of grease to the corners on the square shank of the 2-5/16" ball.
5. **Engage pin.** Move handle toward rear of truck until the handle retracts and engages the 2-5/16" ball.

**⚠ When installed properly the latch pin will pass through the 2-5/16" ball and fully engage through both walls of the hitch receiver. Failure of the pin to engage the ball and hitch properly could result in a loss of attachment between the trailer and the tow vehicle.**

## OPERATION & MAINTENANCE

- Always be sure that latch pin is fully engaged in the socket before towing.
- Inspect hardware connections before towing to be sure that they are secure.
- Measure and determine turning clearance with cab before towing unfamiliar trailers. Additional products for increasing turning clearance are available from B&W.
- When inverting the ball, inspect the ball's relationship with the truck's differential and drive line to ensure proper clearance. **DO NOT INVERT THE BALL WHEN HAULING HEAVY LOADS ON 2 WHEEL DRIVE TRUCKS.** A plug for the socket is available from B&W so that the ball may be removed and the socket may be covered when hauling heavy loads.
- Periodically grease the corners on the square shank of the 2-5/16" ball.