

# <THESE INSTRUCTIONS MUST BE GIVEN TO THE END USER>



B&W Trailer Hitches

## Custom 5th Wheel Hitch Mounting Rail Installation Instructions

# MODEL 2400

2005-2010 Ford 3/4 & 1 Ton HD Long & Short Bed Trucks

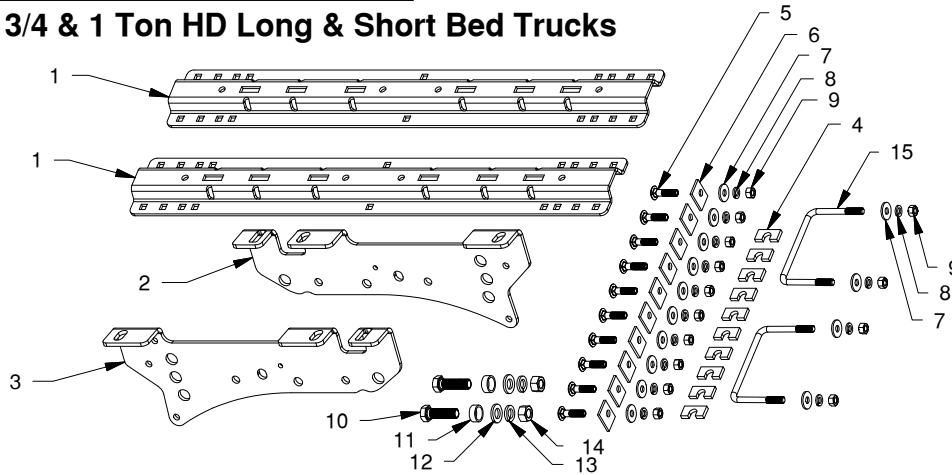

PARTS LIST			PARTS LIST		
ITEM	QTY	DESCRIPTION	ITEM	QTY	DESCRIPTION
1	2	Mounting Rail (Separate Box)	9	14	1/2" Finish Nut
2	1	Frame Bracket, Passenger	10	2	3/4" X 2-1/2" Cap Screw
3	1	Frame Bracket, Driver	11	2	Mounting Washer
4	10	5/16" U-Shaped Spacer	12	2	3/4" Flat Washer
5	10	1/2" X 2" Carriage Bolt	13	2	3/4" Split Lockwasher
6	10	Offset Rectangle Washer	14	2	3/4" Finish Nut
7	14	1/2" Flat Washer	15	2	1/2" X 6-3/4" X 4" U-Bolt
8	14	1/2" Split Lockwasher			

### **⚠ WARNING** Failure to comply with the safety information in these instructions could result in serious injury or death.

- ⚠ Read all installation and operating instructions along with all labels before using this product.
- ⚠ Without proper knowledge, towing can be a dangerous activity. Understand all the risks involved with towing before proceeding. For information on towing safety, see **"The Trailer Handbook: A guide to Understanding Trailer and Towing Safety"**
- ⚠ This product was designed to fit vehicles in their original, "as manufactured" condition. Compatibility with vehicles having replacement parts, or other modifications is not guaranteed. Inspect vehicle for modifications before installation of this product.
- ⚠ Do not modify this product in any manner. Doing so could alter its integrity and lead to a loss of attachment between the trailer and the tow vehicle.
- ⚠ Do not exceed tow or tongue rating of coupler, tow or tongue rating of hitch, or tow or weight ratings of truck or trailer. See vehicle and trailer manufacturer information for ratings. Exceeding these ratings may cause damage to towing components or loss of attachment between the trailer and truck.
- ⚠ Adding components to the chassis of any vehicle can be hazardous. There is potential for unexpected combustion of fuel, electric shock, burns, shifting or falling of unstable vehicle, damage to vehicle, injury from tool usage and many other hazards. This installation must be completed by someone who is aware of the hazards involved. This person must be knowledgeable of proper safety procedures for a vehicle modification of this nature and for usage of the equipment required to perform the installation.

# PREPARING TO INSTALL

**NOTICE:** If truck is equipped with a removable bed liner or mat, it should be removed or it must be cut to allow the mounting rails to connect directly with the bed. It is acceptable to install the mounting rails over a spray in bed liner.

**NOTE:** Remove all parts from the packaging and familiarize yourself with all the parts and tools required. Use the parts list on the front page to verify that all parts and hardware are present.

Installation of the mounting rails requires several common tools and a few specialized tools. Below is a listing of equipment used during a typical installation.

- Impact wrench or ratchet with 3/4" & 1-1/8" sockets
- 3/4" and 1-1/8" box end wrench
- A drill and 1/8" & 9/16" Drill bits
- Patriot 5th wheel or Slider Base
- Hammer
- Flashlight
- Tape Measure
- Eye Protection
- Ear Protection
- Torque Wrench
- Center Punch

## DRILL REAR MOUNTING HOLES

- 1. Layout the rear mounting rail.** Place a mounting rail onto the bed of the truck. Hook a tape measure over the rear edge of the bed (not on any part of the tailgate), measure the location for the mounting rail as shown in figure A1. Next, center the mounting rail in the bed by measuring the distance on either side from the edge of the rail to the sides of the bed. The rail will be centered when both measurements on either side of the rail are the same.

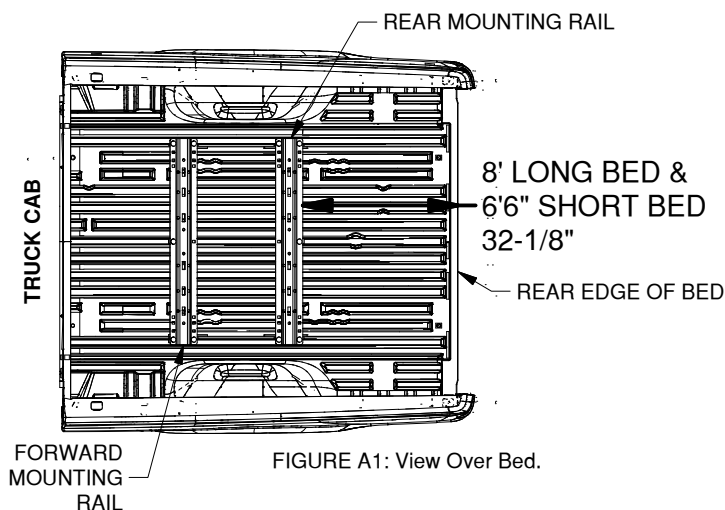

FIGURE A1: View Over Bed.

**IMPORTANT:** The mounting rail is designed to install only at the described location. Failure to place the mounting rail precisely may result in added difficulty during installation and/or property damage.

- 2. Mark hole locations:** While carefully ensuring the mounting rail does not move, use a center punch tool to mark the 5 drill locations on the rear rail. See figure A2 for hole marking locations for this installation (forward rails will install on a later step). Once all 5 rear rail locations are clearly marked, move the bed rail out of the way and drill each location with an 1/8" drill.

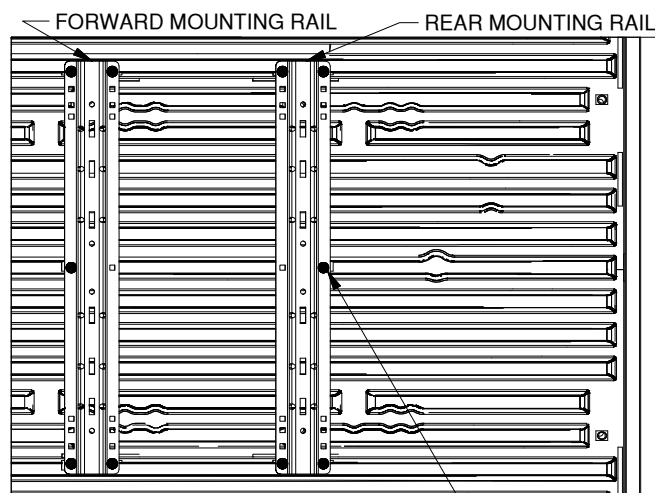

Figure A2: Detail view over bed, showing drill locations for the forward and rear bed rails.

**DRILL LOCATIONS HIGHLIGHTED BY BLACK DOTS**

- ⚠** The fuel tank of the truck may be directly below the area of the bed which needs to be drilled. Always carefully examine the area under the truck where modification will occur. Make certain that the tank, or other equipment, is not damaged during drilling. Damage to the tank may result in property damage, serious injury or death.

- 3. Check hole locations:** Using the frame brackets, align each bracket to the side of the frame where the brackets will be installed, see figures A3 & A4. Check that the 1/8" holes are centered within the slots in the frame brackets. If the 1/8" drilled holes are not centered re-drill the 1/8" holes until the brackets and the drilled holes are aligned.

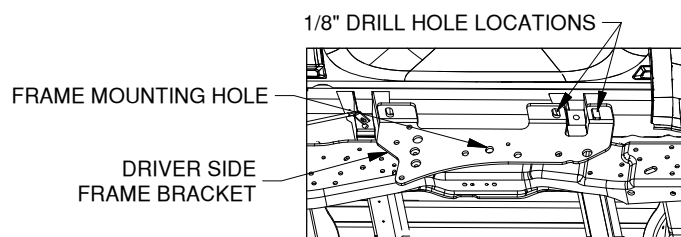

Figure A3: View looking into driver side wheel well.

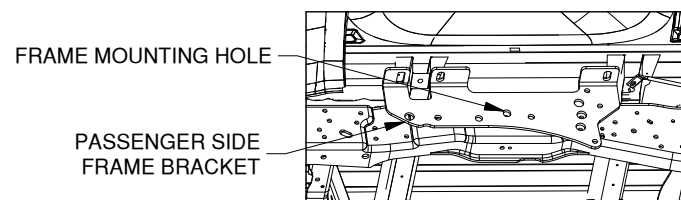

Figure A4: View looking into passenger side wheel well.

- 4. Enlarge the holes.** Use the 1/8" holes as pilots, drill out each hole with a 9/16" bit.

# INSTALL FRAME BRACKETS

Install the side frame brackets. Each sideplate will attach to the frame using a 3/4" cap screw and a 1/2" U-bolt.

1. **Install 3/4" Bolt.** Start by locating a 3/4" X 2-1/2" cap screw, mounting washer, 3/4" flat washer, 3/4" lock washer, 3/4" finish nut. Pass the 3/4" cap screw through the frame bracket and install a mounting washer onto the cap screw on the other side of the frame bracket. While holding the cap screw and mounting washer in place, pass the cap screw into the frame of the truck, see figure B1. Attach the 3/4" cap screw with a 3/4" flat washer, 3/4" lock washer, and 3/4" finish nut, as shown in figure B2. Do not tighten at this time.

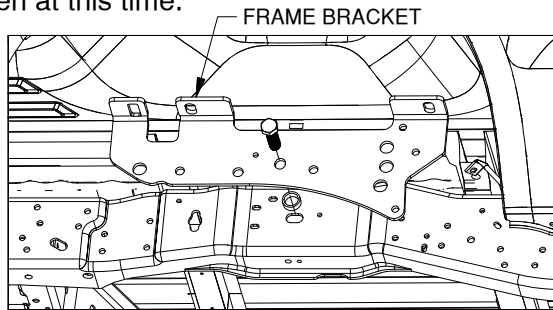

Figure B1: View looking into passenger side wheel well.

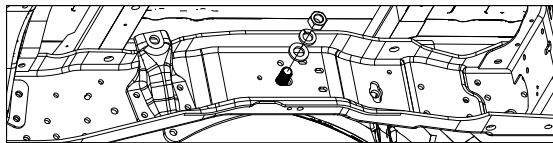

Figure B2: View under bed looking at the inside passenger side frame.

2. **Install the U-bolt.** Next locate the 1/2" x 6-3/4" x 4" U-bolt, two 1/2" flat washers, 1/2" lock washers, and 1/2" finish nuts. Pass the U-bolt over the inside of the frame and into the two mounting holes in the frame bracket, as shown in figure B3. Attach the U-bolt to the frame bracket with the two 1/2" flat washers, 1/2" lock washers and 1/2" finish nuts. Do not tighten at this time. Repeat this steps 1 & 2 for the other side of the truck frame.

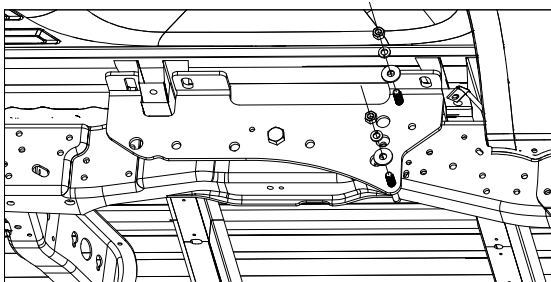

Figure B3: View looking into passenger side wheel well.

# INSTALL REAR MOUNTING RAIL

**NOTICE:** Due to the corrugation in the truck bed, U-shaped spacers are provided to function as space fillers between the mounting rails and the kit attachment hardware. Always place a u-shaped spacer in the gap either above the bed (between the mounting rail and the bed) or below the bed (between the bed and the side mounting brackets). Failure to use u-shaped spacers will result in property damage when hardware is tightened.

1. **Install the rear mounting rail.** Re-position the rear mounting rail over the drilled 9/16" holes in the bed. Install a 1/2" Carriage bolt through the mounting rail into each of the five drilled holes, as shown in figure C1.

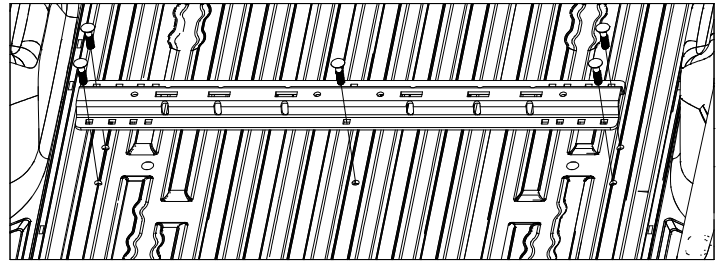

Figure C1: View looking into truck bed from rear of truck

2. **Install the rear mounting rail, cont.** Under the bed install four u-shaped spacers around each carriage bolt between the bed and the frame brackets. Next, install offset square washers, 1/2" flat washers, 1/2" lock washers and 1/2" finish nuts on each of the carriage bolts, see figure C2. Hand tighten each nut.

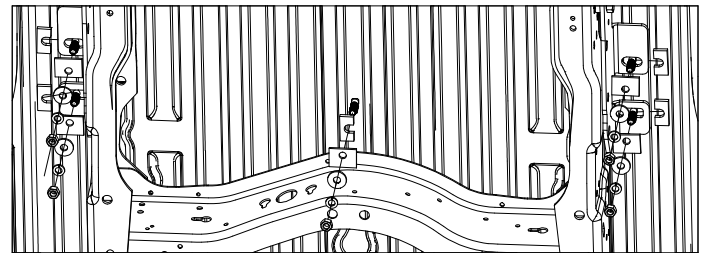

Figure C2: View looking into truck bed from rear of truck

# INSTALL FORWARD MOUNTING RAIL

1. **Position the forward mounting rail.** For this step the base which will be used in the mounting rails is required. Place a mounting rail into the truck bed in front of the rear mounting rail. Place the base over the rail attachment points and carefully lower it until the pin tabs pass through the attachment points on the rear mounting rail. Attach the forward mounting rail to the forward mounting points on the base. The base should rest flat against the top of the rails. See figure C3. With the base still attached ensure that the forward rail is centered in the truck bed.

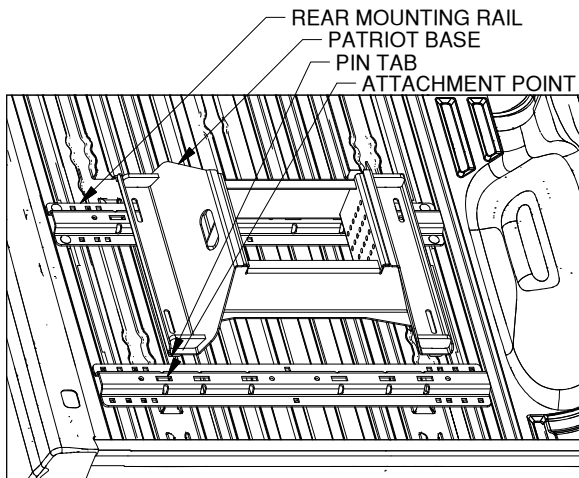

Figure C3: View into truckbed looking towards tailgate.

2. **IMPORTANT:** Before drilling forward mounting holes pull the RV base towards the rear of the truck and push the forward rail towards the cab of the truck to correctly space the mounting rails, see figure C4.

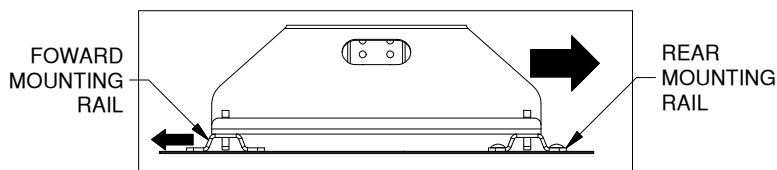

Figure C4: Side view of RV base and mounting rails.

3. **Drill forward mounting holes.** Using the same methods as used for the rear mounting rail, mark, drill, check, and enlarge the holes for the forward mounting rail. Refer to "DRILL REAR MOUNTING HOLES" section, steps 2 through 4, on a previous page. Notice that the hole locations are slightly different than the rear rail, see figure A2 (on the second page).

4. **Install forward mounting rail.** Re-position the forward mounting rail over the drilled 9/16" holes in the bed. Install a 1/2" Carriage bolt through the mounting rail into each of the five drilled holes, as shown in figure C5.

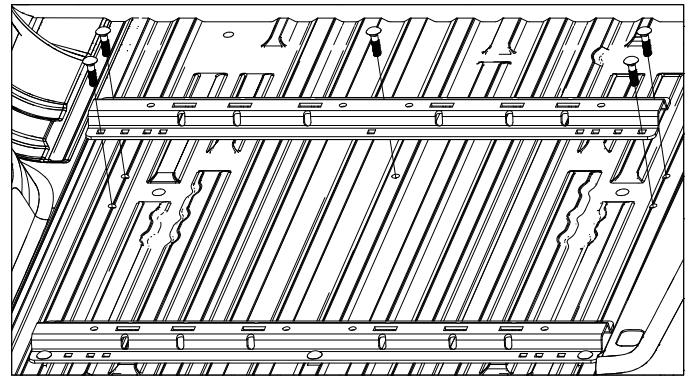
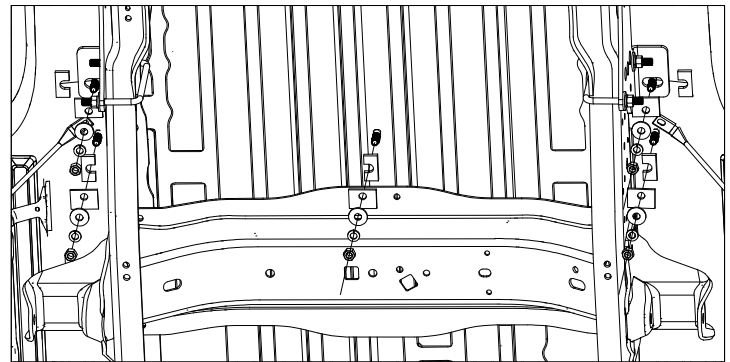

Figure C5: View looking into truck bed from rear of truck.

5. **Install the foward mounting rail, cont.** Under the bed place u-shaped spacers around the two rear carriage bolts between the bed and the frame brackets. Next, while using u-shaped spacers on the remaining carriage bolts, install offset square washers, 1/2" flat washers, 1/2" lock washers and 1/2" finish nuts on each of the carriage bolts, see figure C6. Hand tighten each nut.



View C6: View under bed looking up toward the cab of the truck.

6. **Tighten hardware.** Using a torque wrench, first torque all the 1/2" nuts in the mounting rails to 80 ft-lbs. Second torque all 3/4" nuts in the frame brackets to 100 ft-lbs. Lastly torque all 1/2" nuts in the frame brackets to 80 ft-lbs.