



**B&W Trailer Hitches**  
 1216 Hawaii Road / PO Box 186  
 Humboldt, KS 66748

**NOTE:** *we recommend reading instructions before beginning the installation.*

## Frame to Rail Bracket Kit 3201 Installation Instructions For use in conjunction with 3200 Universal Rail Kit.

# Model 3201

**TOOLS REQUIRED FOR 3200 & 3201 INSTALLATION**  
 3/16" DRILL BIT    17/32" DRILL BIT    3/4" SOCKET AND WRENCH    100 lb-ft TORQUE WRENCH

3201 HARDWARE KIT	QTY:
A - Carriage bolt 1/2-13 x 1 1/2"	4
B - Left side mounting bracket	2
C - Right side mounting bracket	2
D - Locking strap	4
E - 1" Reducing washer	2
F - 13/16" Reducing washer	2

3200 HARDWARE KIT	QTY:
1 - Carriage bolt 1/2-13 x 2"	10
2 - Mounting rail	2
3 - Slotted spacer	10
*4 - Block spacer	2
*5 - Short mounting bracket	2
6 - Flat washer	10
7 - Lock washer	18
8 - Finish nut	18
#9 - Knurled bolt	8
*10 - Long mounting bracket	2
*11 - Carriage bolt 1/2-13 x 4-1/2"	2
*12 - Tube spacer	2
13 - Fish wire	2

\* = Items not used in this installation  
 # = Only 4 required for this installation

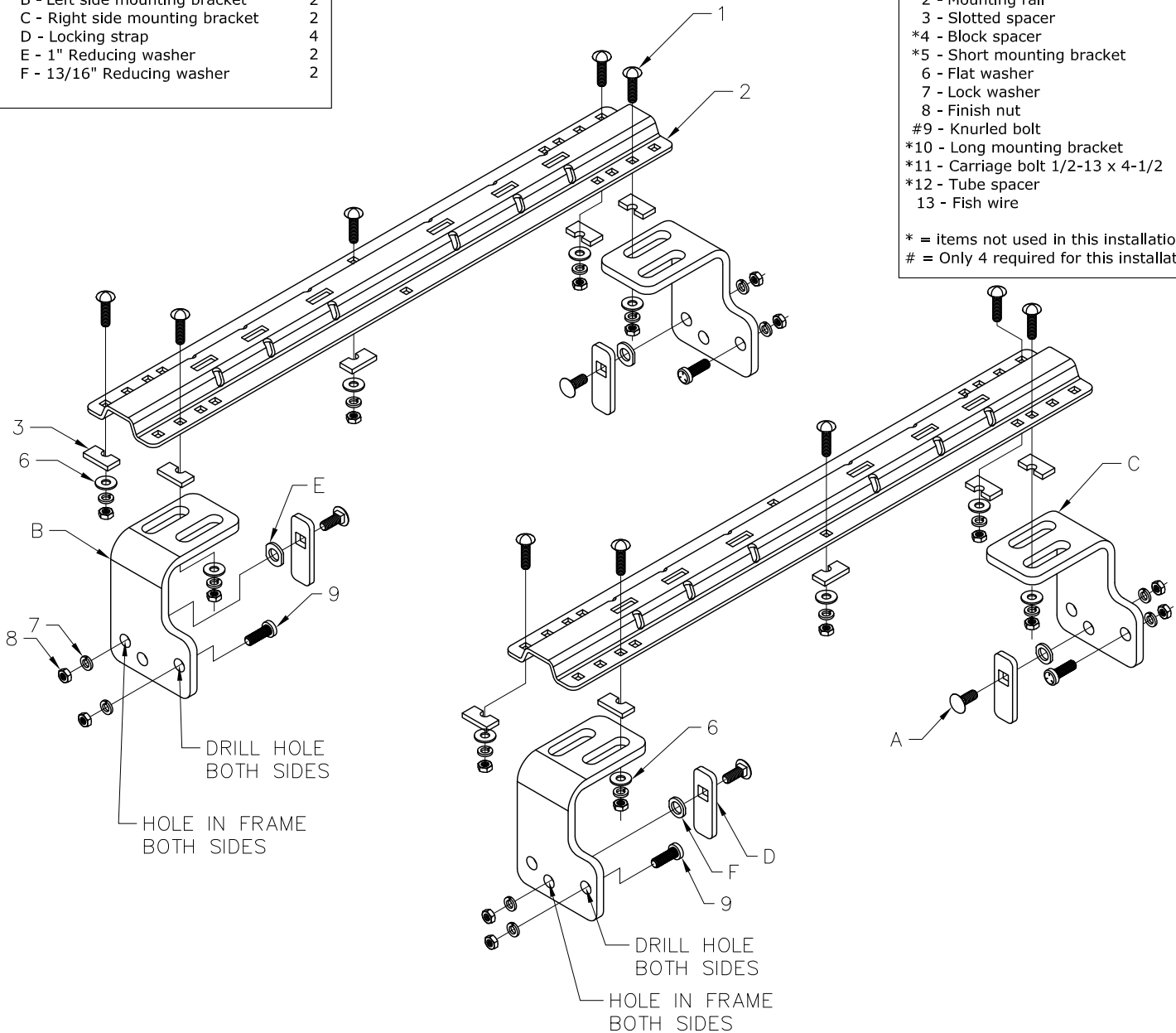

## Bracket kit 3201 for Ford 2004 - 2014 F-150, 5.5', 6', & 8' BEDS

Read these instructions completely and also pages 1 & 2 of 3200 universal rail instructions before beginning installation. Failure to do so could result in significant vehicle damage.

**CAUTION:**

Check for obstructions below the truck bed before drilling. Failure to do so could result in damaged fuel or brake lines, structural members, etc. B&W does its best to communicate tow vehicle manufacturer changes; however, it is ultimately the responsibility of the installer to prevent damage due to installation.

1. Do not drill through both frame walls. Only drill through the wall of the frame to which bracket is mounted.
2. Before beginning, find the parallel rows of bed sill spot welds in bed of the truck. No drilling should be done in the 4" space between parallel rows of spot welds where the bed sill is located.
3. Remove the jounce block from bottom of frame on both sides.
4. When brackets are in place, one of the two front holes should line up with a hole in the frame. Use the rearward hole in each bracket to drill a  $\frac{17}{32}$ " hole in the frame.
5. Using the fishwire supplied with the 3200 universal rail kit, pull the carriage bolts and locking plates through the hole in the bottom Edge of Truck Bed frame (where the jounce block was removed). Pass the fishwire through the existing frame hole and the hole in each bracket that it lines up with. On the forward brackets, a carriage bolt, locking plate and a 1" reducing washer should be pulled through the forward hole. On the rearward brackets a carriage bolt, locking plate and 13/16" reducing washer will be pulled through the middle hole. In the drilled holes use the fishwire to pull knurled bolts through. The knurled bolts do not require a locking plate. Finish fastening the bracket to the frame with lock washers and finish nuts. Torque all  $\frac{1}{2}$ " fasteners to 85 ft-lbs.
6. Replace the jounce blocks.

USE ASSEMBLED PATRIOT BASE TO POSITION FRONT RAIL.

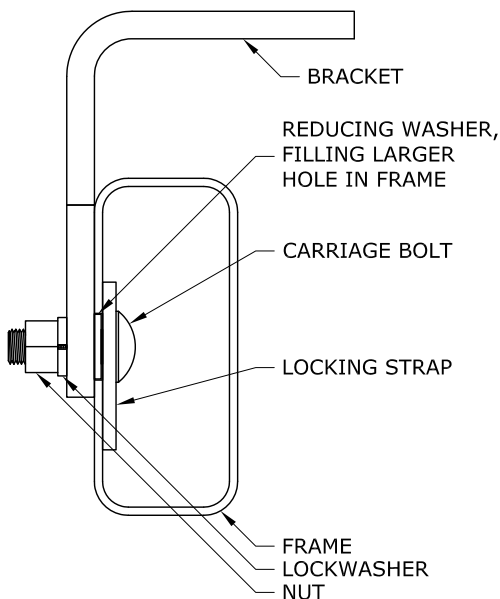
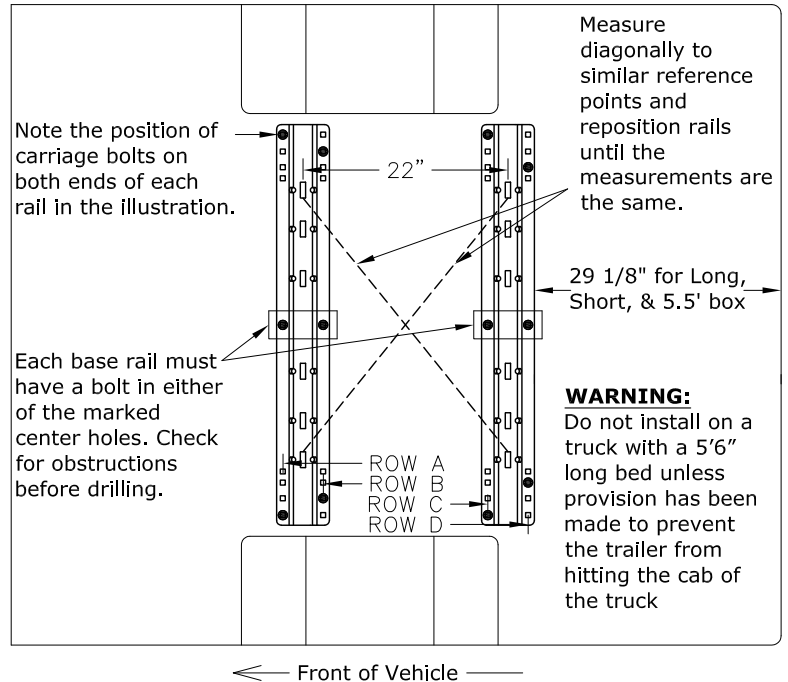

END VIEW OF DRIVER SIDE (F150 SHOWN)

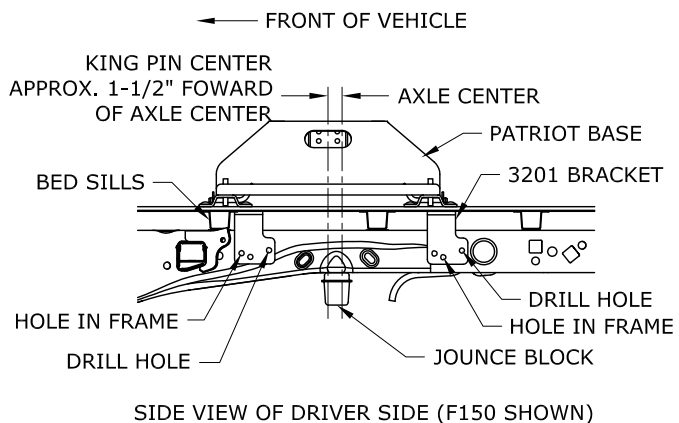

SIDE VIEW OF DRIVER SIDE (F150 SHOWN)