



B&W Trailer Hitches
 1216 HWY 224 / PO Box 186
 Humboldt, KS 66748

NOTE: *we recommend reading instructions before beginning the installation.*

Frame to Rail Bracket Kit 3202 Installation Instructions For use in conjunction with 3200 Universal Rail Kit.

Model 3202

TOOLS REQUIRED FOR 3200 & 3202 INSTALLATION
 1" DRILL BIT 3/16" DRILL BIT 17/32" DRILL BIT 3/4" SOCKET AND WRENCH 100 lb-ft TORQUE WRENCH

3202 HARDWARE KIT		QTY:
A - Left side mounting bracket		1
B - Right side mounting bracket		1

3200 HARDWARE KIT		QTY:
1 - Carriage bolt 1/2-13 x 2"		10
2 - Mounting rail		2
3 - Slotted spacer		10
4 - Block spacer		2
*5 - Short mounting bracket		2
6 - Flat washer		10
7 - Lock washer		18
8 - Finish nut		18
9 - Knurled bolt		8
10 - Long mounting bracket		2
11 - Carriage bolt 1/2-13 x 4-1/2"		2
12 - Tube spacer		2
13 - Fish wire		2

* = Items not used in this installation

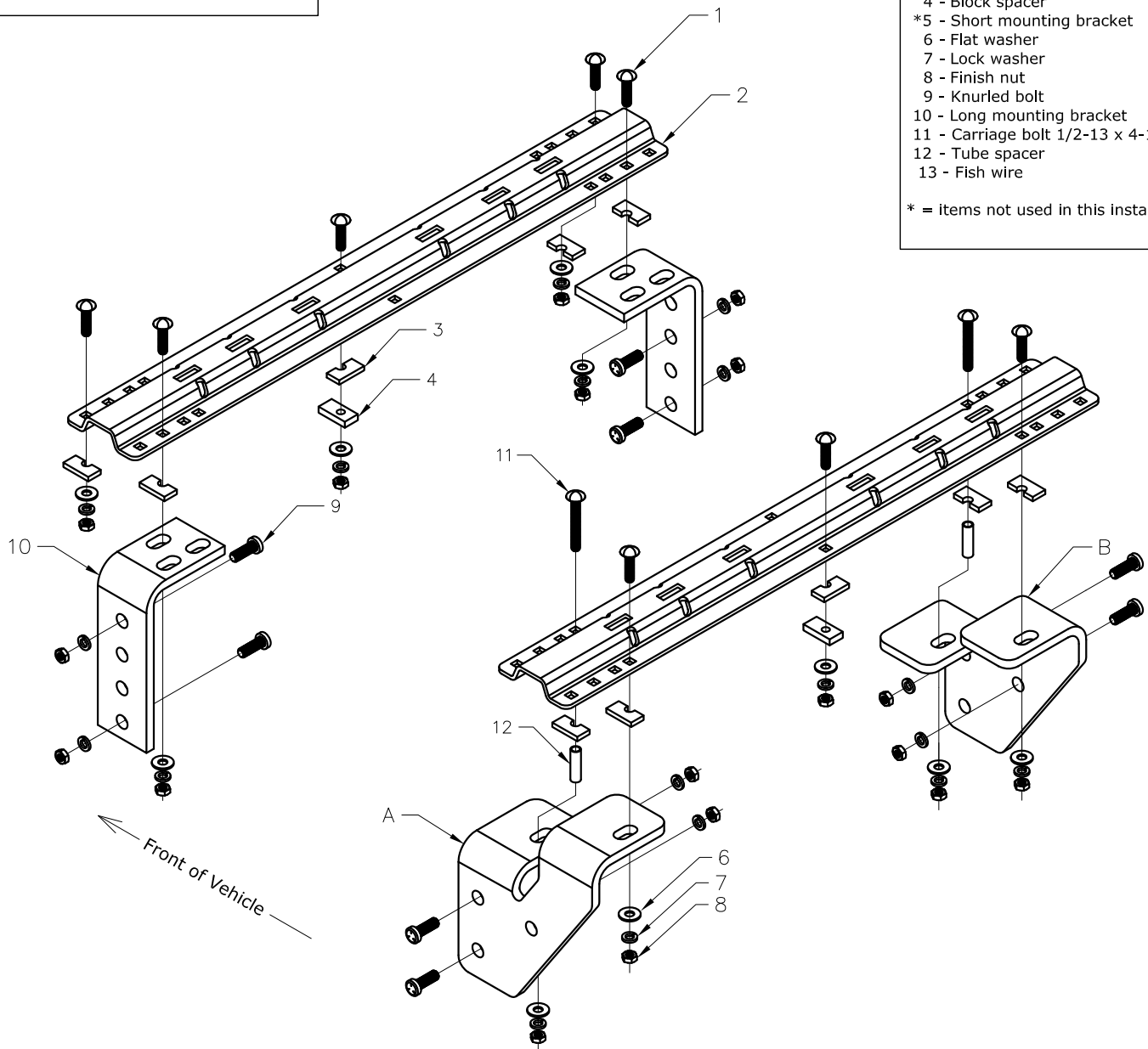

Read these instructions completely and also pages 1, 2 & 8 of 3200 universal rail instructions before beginning installation. Failure to do so could result in significant vehicle damage.

CAUTION:
Check for obstructions below the truck bed before drilling. Failure to do so could result in damaged fuel or brake lines, structural members, etc. B&W does its best to communicate tow vehicle manufacturer changes; however, it is ultimately the responsibility of the installer to prevent damage due to installation.

1. Tube spacers and 4 1/2" carriage bolts used to attach through rearward Bed Sill (Row C). It may be necessary to shorten the tube spacer to ensure that the hitch rail lays evenly across the corrugated truck bed surface. Use a straight edge laid across the bed surface to determine if the tube is the correct length for your truck. The tube can be cut or ground to the exact height.
2. Rib neck bolts will need to be pulled through rearward access holes in frame with supplied pull wire (see below).
3. Do not drill thru both walls of frame. Drill only thru wall of frame to which bracket is mounted.
4. It is very important that brackets in Row B are against rear side of Bed Sill as shown. Due to dimensional instability in Bed Sill placement with the Dodge truck, interference could result when drilling in Row C. Observe caution note below and double check all areas prior to drilling.
5. Rear brackets can be mounted to frame with (2) bolts in any combination of the three bracket holes.
6. *Due to tubular frames having thinner walls than channel frames, extra caution needs to be used when mounting with the optional welding.

USE ASSEMBLED PATRIOT BASE TO POSITION FRONT RAIL.

Drill through Bed Sill (ROW C) with 17/32" drill. Open up hole through truck bed only with 1" dia. drill. Drop tube spacer through hole in truck bed to avoid crushing Bed Sill when torquing 4 1/2" carriage bolt. Grind tube spacer if it does not allow rail to sit flush with top of bed floor.

Drill 2 center holes shown in addition to 8 holes for 3200 kit. Install 1/2" carriage bolts, slotted spacer above or below bed to fill bed corrugation, and block spacer below bed with washer and nut.

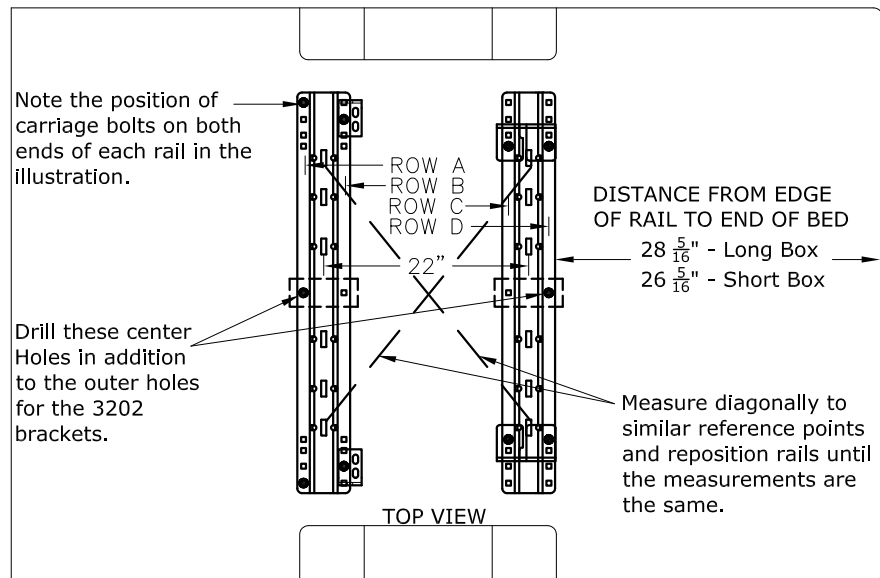

← Front of Vehicle →

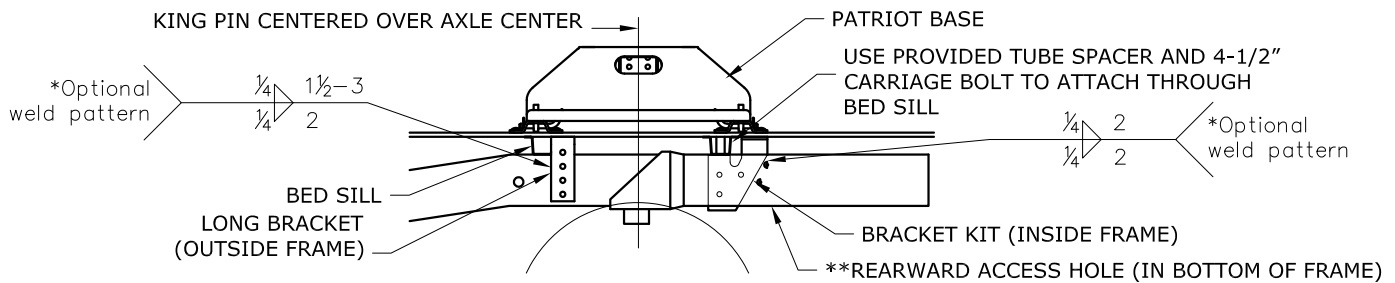

← Front of Vehicle →

VIEW OF DRIVER SIDE (2500 RAM SHOWN)