



# Installation Instructions

PART NUMBERS: 76031, 84031, CQT76031

## Applications:

Years	Make	Models
2013-Current*	Nissan	Pathfinder
2013	Infiniti	JX35
2014-Current*	Infiniti	QX60

## Installation Time: **24 min.**

The time listed above is the average time for professional installers. If you do not feel comfortable performing this installation on your own or are in need of assistance, please contact a professional installer.



Representative Vehicle Photo

## Equipment Required:

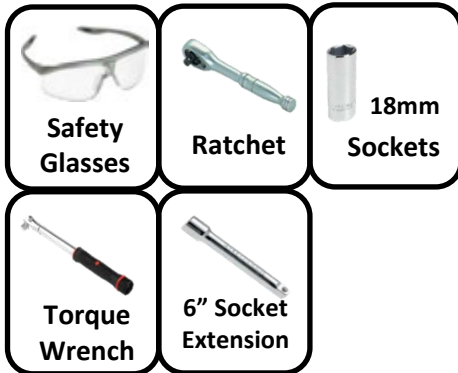

**DO NOT EXCEED LOWER OF TOWING VEHICLE  
MANUFACTURER'S RATING OR:**

Hitch Type	Max Gross Trailer Weight	Max Tongue Weight
Weight Carrying	6000 lb. (2722 kg)	900 lb. (408 kg)
Weight Distributing	6000 lb. (2722 kg)	900 lb. (408 kg)

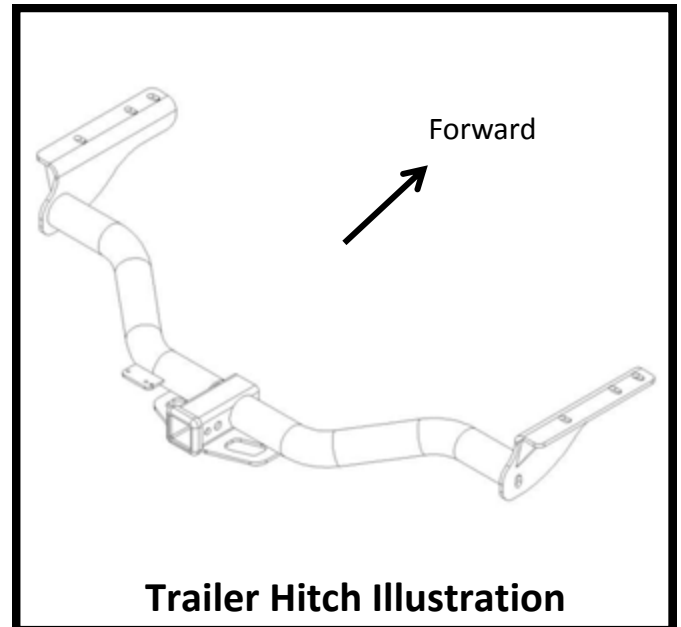

Trailer Hitch Illustration





Always wear **SAFETY GLASSES**  
when installing hitch

# Installation Instructions

## PART NUMBERS: 76031, 84031, CQT76031

**Fastener Kit: 76031F**

①	Qty. (6)	Bolt CL 8.8 M12 x 1.25 x 35mm	
②	Qty. (6)	Flat Washer 1/2	
③	Qty. (6)	Locking Washer 1/2	

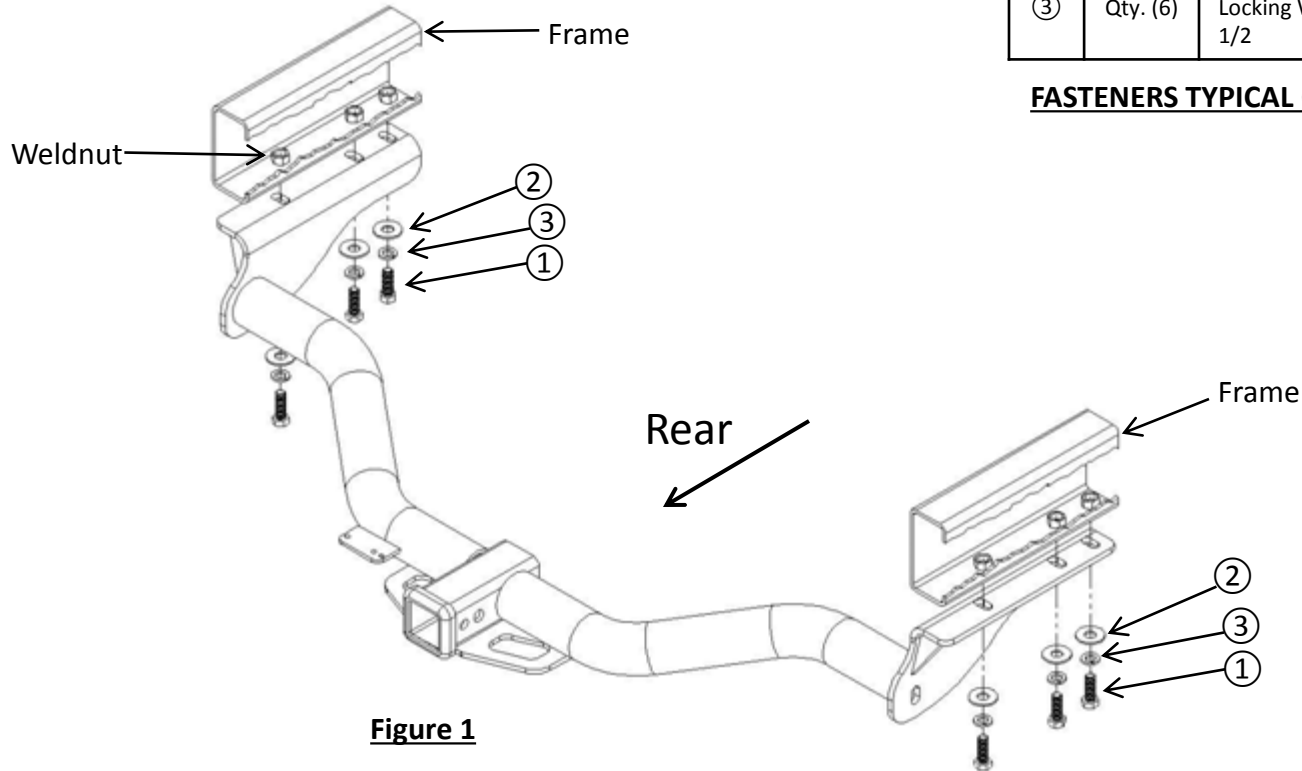

**FASTENERS TYPICAL ON BOTH SIDES**

**Figure 1**

1. **Remove tie down brackets** and return to customer.
2. **Raise Hitch into Position** – Raise the hitch into position and install three M12 Bolts, three 1/2" Flat Washers, and three 1/2" Locking Washers into weldnuts on each side.
3. **Tighten all M12 CL8.8 fasteners with a torque wrench to 76 ft-lbs (103 N-m).**

 **Proper torque is needed to keep the hitch secure to the vehicle when towing.**

Note: Check hitch frequently, making sure all fasteners and ball are properly tightened. If hitch is removed, plug all holes in trunk pan or other body panels to prevent entry of water and exhaust fumes. A hitch or ball which has been damaged should be removed and replaced. Observe safety precautions when working beneath a vehicle and wear eye protection. Do not cut access or attachment holes with a torch.

This product complies with safety specifications and requirements for connecting devices and towing systems of the state of New York, V.E.S.C. Regulation V-5 and SAE J684.

1. **Remove tie down brackets** and return to customer.



2. **Raise Hitch into Position** – Raise the hitch into position and install three M12 Bolts, three 1/2" Flat Washers, and three 1/2" Locking Washers into weldnuts on each side.



2. **Continued**



3. **Tighten all M12 CL8.8 fasteners with a torque wrench to 76 ft-lbs (103 N-m).**  
▲ Proper torque is needed to keep the hitch secure to the vehicle when towing.

