

SN57LS-2 Back

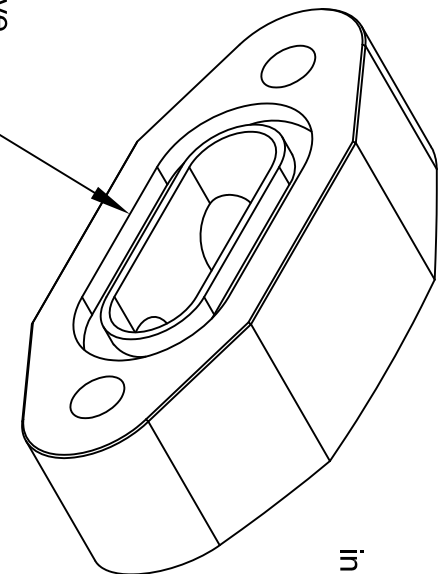

Insert Included O-ring in groove
on back of adapter. Lubricate
O-ring with engine oil.

Attach oil pressure sender
in either $\frac{1}{8}$ " NPT hole. DO NOT
use teflon tape on threads.
Extra hole available for
optional hardware.

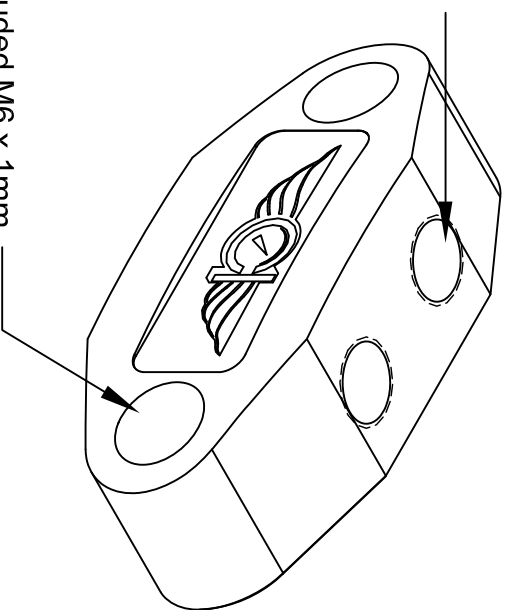

SN57LS-2 Front

Use 2x included M6 x 1mm
screws to attach to engine.
Torque screws to 9-10 ft. pounds.
Blue Loc-tite is recommended to
be used on screw threads.