

FC-1 Temperature Control Switch

Made in the U.S.A

Installation and Operating Instructions:

1. The **FC-1 Temperature Control Switch** will control the water temperature to the shirt and provide on/off functionality. When in the **"BYPASS"** position, the toggle switch on the FC-1 allows the user to control the speed of the water pump in the cooling unit with the adjustable dial. When in the **"ON"** position, the FC-1 bypasses the dial and runs the system at full capacity. The **"OFF"** position turns the pump off
2. Use only on a 12 volt system.
3. To connect the switch to your racecar, wires are marked RED - Positive and BLACK- Negative.

FC-1

TOP WIRES
BOTTOM WIRES

Connect to the water pump (H2O)
Connect to 12 volt battery

4. Mount control box where desired.

CAUTION

DO NOT CROSS THE WIRES AS THIS WILL PERMANENTLY DAMAGE THE SWITCH. CONNECT GROUND DIRECTLY TO BATTERY AND MUST NOT BE A COMMON GROUND. ENSURE THAT THE POSITIVE AND NEGATIVE WIRES ARE CORRECTLY CONNECTED. FOR ADDITIONAL PROTECTIONS WE RECOMMEND IN-LINE 5 AMP FUSES BE USED:

1. FROM THE POWER TO THE SWITCH.
2. FROM THE SWITCH TO THE PUMP.

(Part# FC-2) Wiring Connections

Rear view of the dual temperature control switch

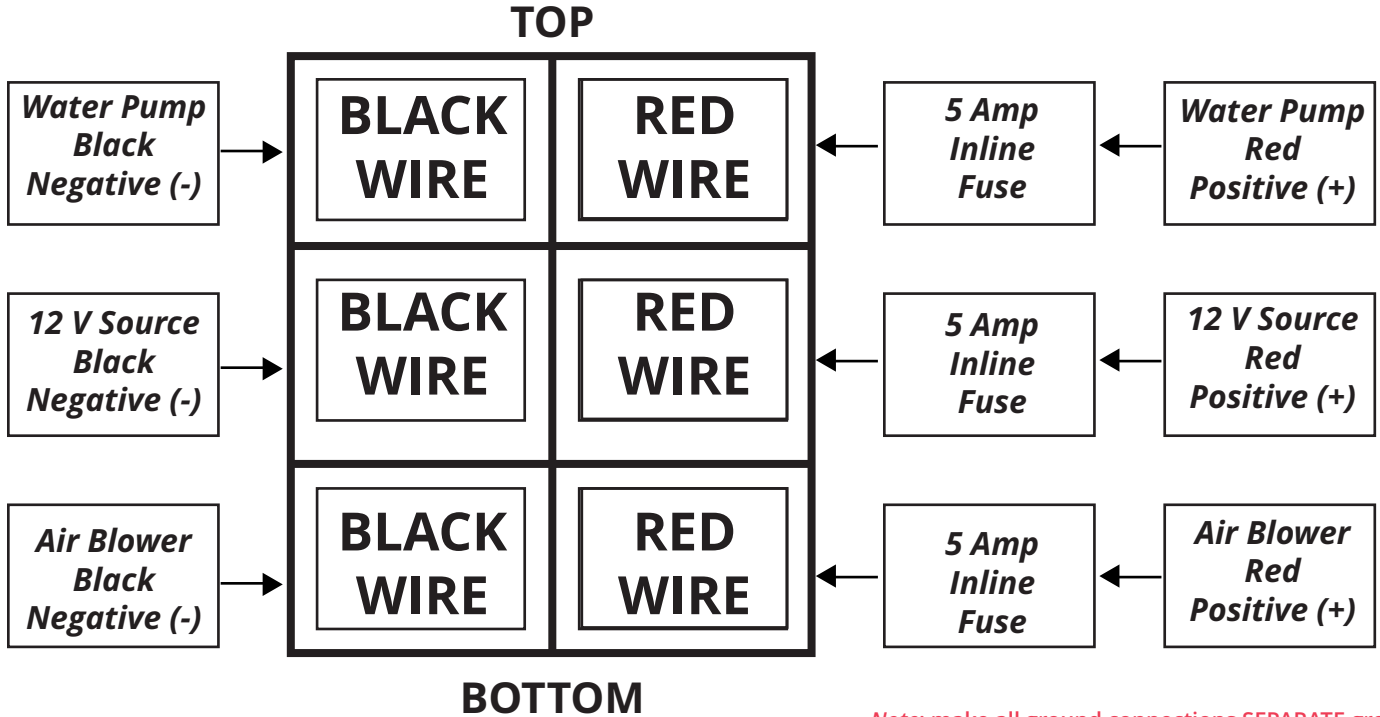

Note: make all ground connections SEPARATE grounds. Common ground connections can damage the switch.

(Part# FC-1) Wiring Connections

Rear view of the temperature control switch

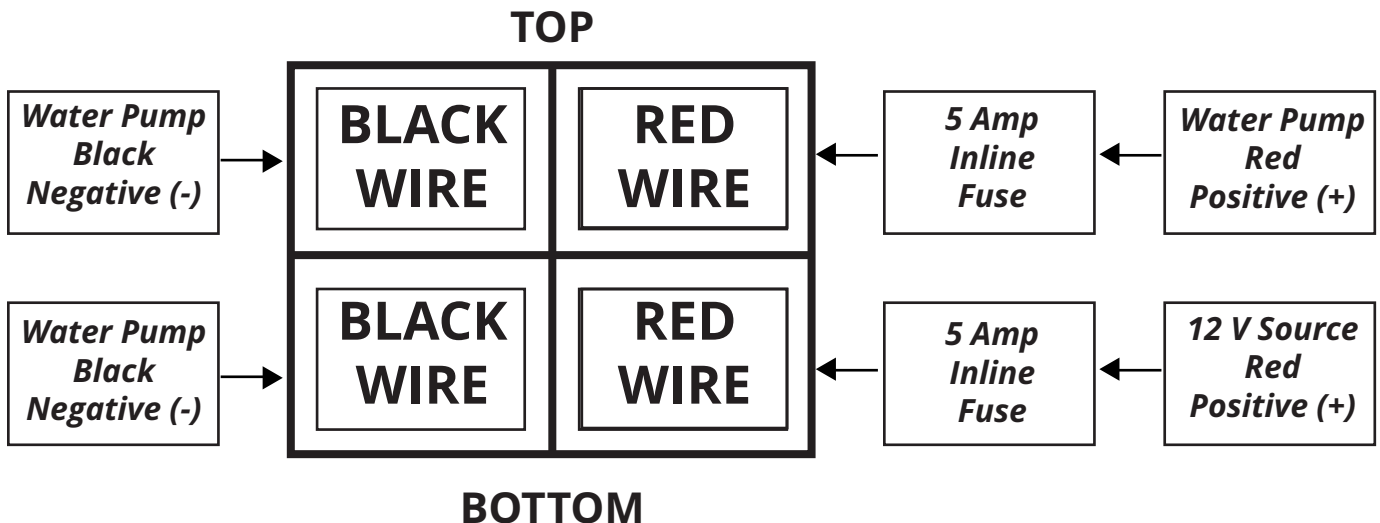

Note: make all ground connections SEPARATE grounds. Common ground connections can damage the switch.