

20 JEEP Gladiator 3.6L

CORSA
PERFORMANCE



IMPORTANT! WARRANTY AND INSTALLATION INSTRUCTIONS

Please Forward All Information to Consumer



NEVER work on a hot exhaust system.
Allow time for the vehicle to cool.

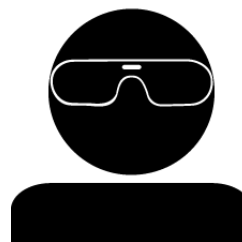

**Always wear eye protection
when working under a vehicle.**

INSTALL DIFFICULTY



RECOMMENDED TOOLS & SUPPLIES

- 3/8" Drive Ratchet
- 3/8" Drive 10mm Socket
- 3/8" Drive 13mm Deep Socket
- 3/8" Drive 15mm Deep Socket
- 3/8" Drive 21mm Deep Socket
- Grommet Pullers
- Soap and Water Solution
- Torque Wrench
- Chain Cutter
- Safety Glasses

Please take time to read and understand these installation instructions.

CORSA recommends that the installation of this system be performed by a qualified service center or professional installer who has the necessary equipment, tools, and experienced personnel. However, if you decide to perform this installation yourself, the use of an additional person may be required.

WARNING: Never work on a hot exhaust system. Allow time for the vehicle to cool. Always wear eye protection when working under a vehicle.

CORSA Performance makes no representation or warranty, expressed or implied that its downpipe or header products and or components there-in comply with federal, state or local emission levels, noise levels, or safety standards or that any of their parts conform with the racing vehicles exemption, unless otherwise noted. The purchaser assumes all responsibility for such use and compliance.

This warranty does not extend to damaged or defect in the finish of a product or to any product, that in the opinion of CORSA Performance, has been misused, damaged by accident or negligence, altered or modified in any way, faulty installation or installed contrary to CORSA installation instructions, or repaired by an unauthorized service facility.

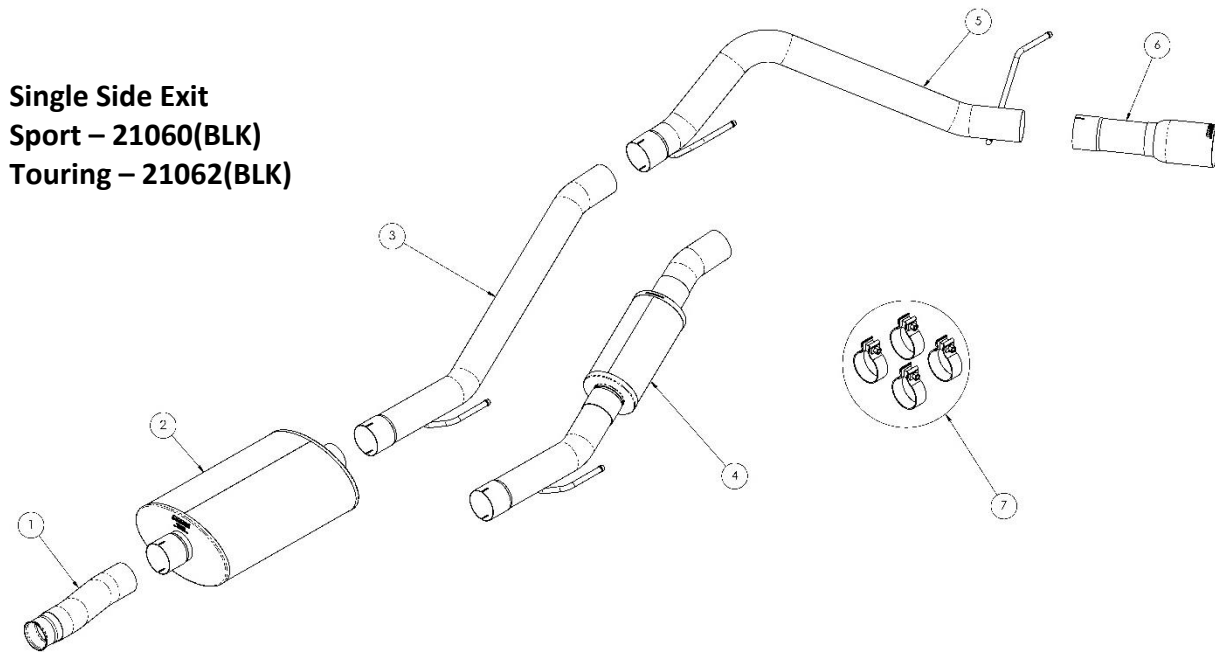

BILL OF MATERIALS

1.	Headpipe Assembly (28JT4000)	2.	Muffler Assembly (28JT2000)
3.	Mid Pipe Assembly (Sport Only) (28JT4008)	4.	Pack Muffler Assembly (Touring Only) (28JT2004)
5.	Single Side Exit Tail Pipe Assembly (28JT4013)	6.	Tip Assembly (25TC3000)
7.	Hardware Kit (18DR7033)		

Dump Style Exit
Sport – 21061
Touring – 21063

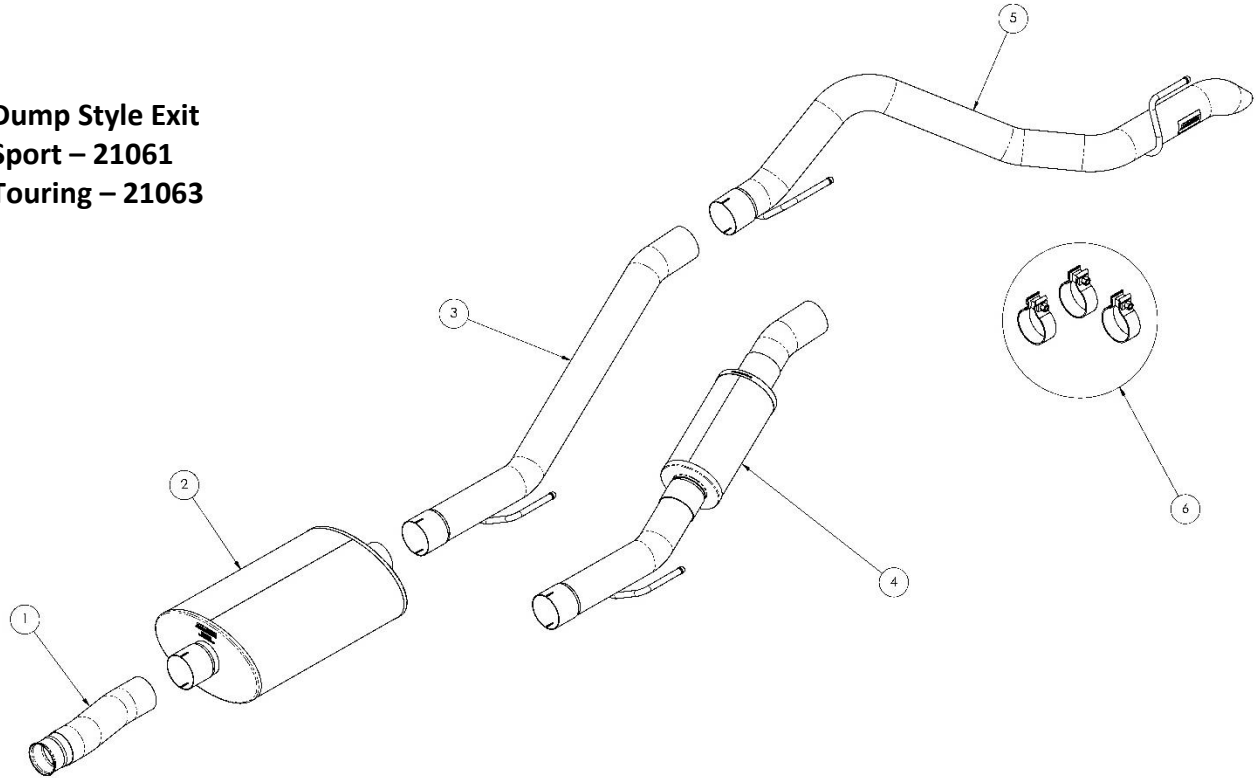

BILL OF MATERIALS

1.	Headpipe Assembly (28JT4000)	2.	Muffler Assembly (28JT2000)
3.	Mid Pipe Assembly (Sport Only) (28JT4008)	4.	Pack Muffler Assembly (Touring Only) (28JT2004)
5.	Dump Exit Tail Pipe Assembly (28JT4013)	6.	Hardware Kit (20FF7026)

CAUTION: Never work on a hot exhaust system. Allow the vehicle to cool for at least an hour and a half. Always wear eye protection when working under a vehicle. It is recommended to use cotton gloves in order to protect stainless steel surfaces from permanent grease and oil stains.

REMOVAL INSTRUCTIONS

FACTORY EXHAUST

There are two methods for removing the factory exhaust. The first method is to remove the exhaust system in one piece (**Steps 1-8**). The second method requires cutting the factory exhaust into two pieces and may be necessary when not using a vehicle lift (**Steps 9-**).

METHOD 1



1. Locate your vehicles tire tool kit and lower the spare tire



2. Using a 10mm socket and ratchet, remove the two bolts on the inside of the spare tire shield.



3. Using a 10mm socket and ratchet remove the two nuts and one bolt on the front side of the spare tire heat shield. Remove the heat shield from the vehicle. Save shield and hardware for installation.



4. To create more room for the removal of the stock exhaust, the track bar will need to be lowered on the driver side. Using a 21mm socket and ratchet remove the bolt securing the track bar.

Continued on Next Page ...

REMOVAL INSTRUCTIONS

FACTORY EXHAUST



5. Remove the bolt and backing nut and lower the track bar. Save hardware for installation.



6. Using a 13mm socket and ratchet, unfasten the rear hanger isolator. Isolator and mounting hardware will be re-used for installation.

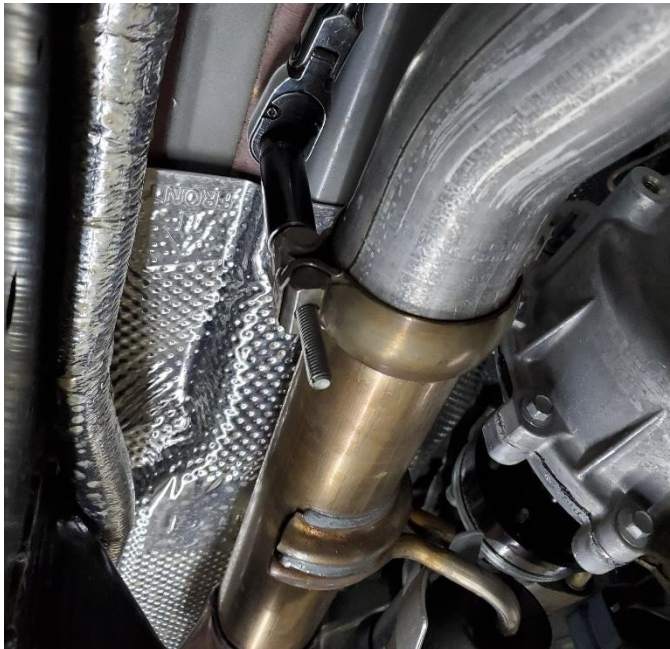

7. Using 13mm socket and ratchet, loosen clamp attaching stock inlet pipe to catalytic converter.
NOTE: Clamp will be used for installation.

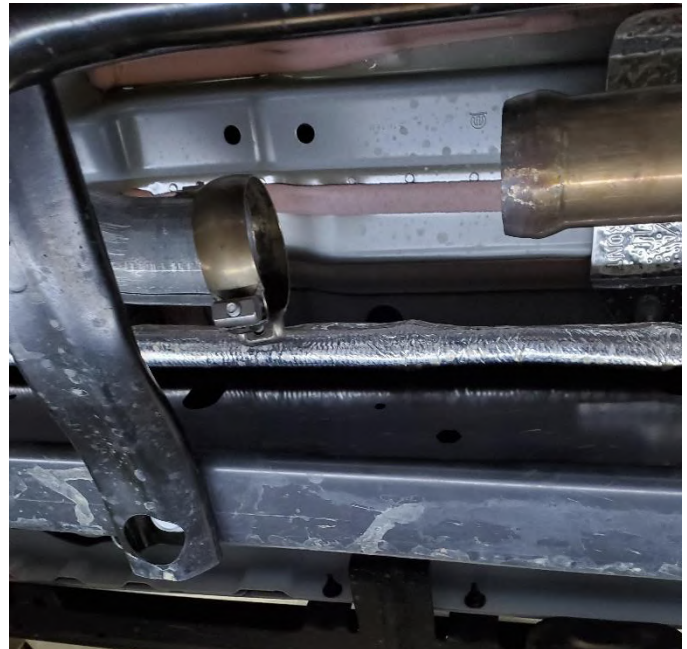

8. Slide entire exhaust to the rear of the vehicle to remove hangers from isolators and to clear brace. Remove entire exhaust from vehicle.
NOTE: A soap and water solution may aid in removal of hangers from rubber isolators.

9. Replace track bar, tightening hardware to factory specs. Re-install heat shield and spare tire.

Continued on Next Page ...

REMOVAL INSTRUCTIONS

FACTORY EXHAUST

Method 2

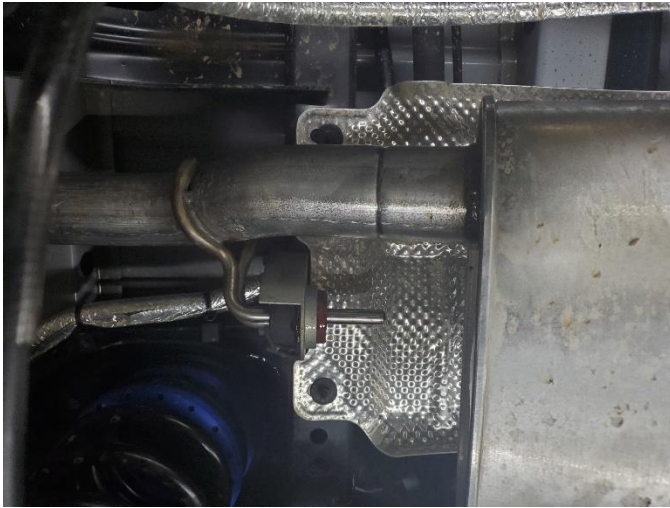

- 10.** Locate the indent in the pipe approximately 2.5" behind the muffler and before the middle hanger. Using a chain cutter, cut the stock exhaust at this indent.



- 11.** Using a 13mm socket and ratchet, unfasten the rear hanger isolator. Isolator and mounting hardware will be re-used for installation. Slide the rear section of the factory exhaust from the middle rubber isolator and remove the rear section of the factory exhaust through the rear of the vehicle.

NOTE: A soap and water solution may aid in removal of hangers from rubber isolators.

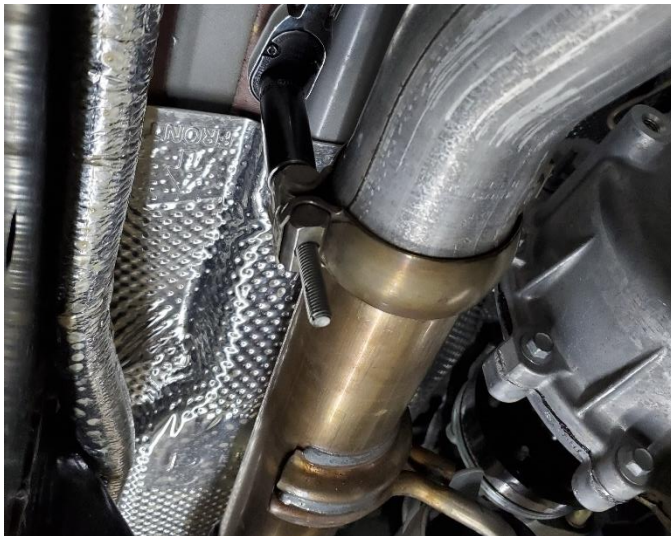

- 12.** Using 13mm socket and ratchet, loosen clamp attaching stock inlet pipe to catalytic converter.
NOTE: Save clamp for installation.



- 13.** Slide the front section of the factory exhaust from the front rubber isolator and remove the front section of the exhaust from the vehicle.
NOTE: A soap and water solution may aid in removal of hangers from rubber isolators.

Step 12 concludes the removal of the factory exhaust.

WARNING! DO NOT SKIP THIS STEP!

Apply the anti-seize lubricant (*supplied*) to the threads **ONLY** of all the clamps and flange bolts. Failure to follow this procedure can cause nuts to seize on clamps and potentially destroy threads.

After applying anti-seize lubricant, be sure to **thoroughly** clean your hands, as lubricant will tarnish stainless steel.

All clamps should be tightened using a properly calibrated Torque Wrench. Using an air impact gun will damage the clamp and reduce its ability to effectively seal the joint. It may also cause the joint to separate, thereby causing damage to your exhaust system and to your vehicle.

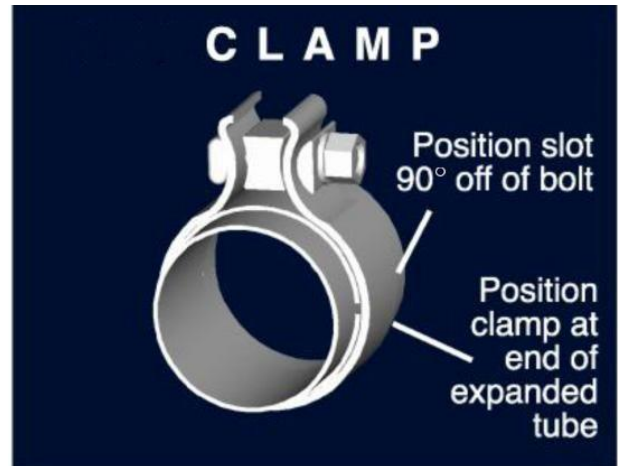

NOTE: Align all clamps so that the center of the clamp bolt is 90 degrees from the notch in the pipe.

INSTALLATION INSTRUCTIONS

CORSA EXHAUST

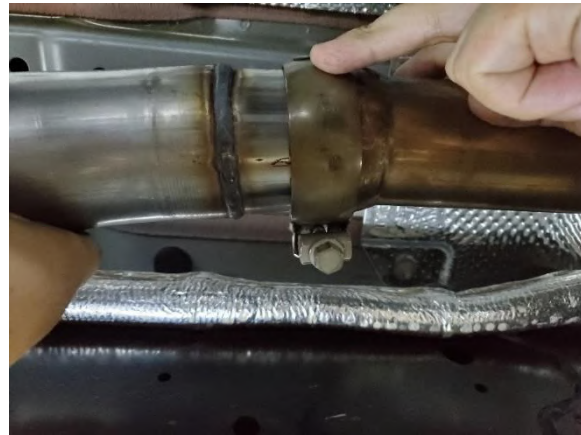
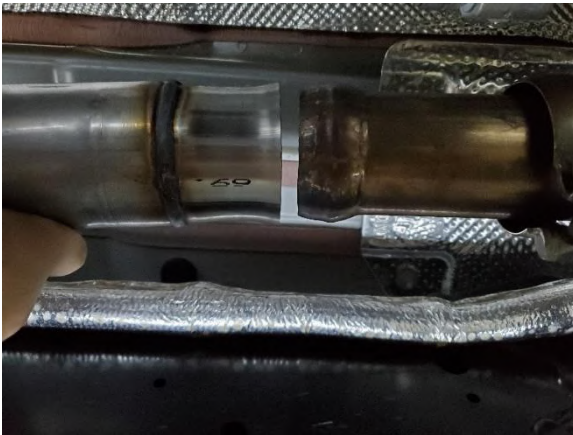

1. Locate headpipe assembly and factory spherical clamp from removal step 7 or 12 depending on removal method. Push spherical inlet of headpipe onto factory exhaust and cover joint with clamp. Snug clamp using 13mm socket and ratchet.

Continued on Next Page ...

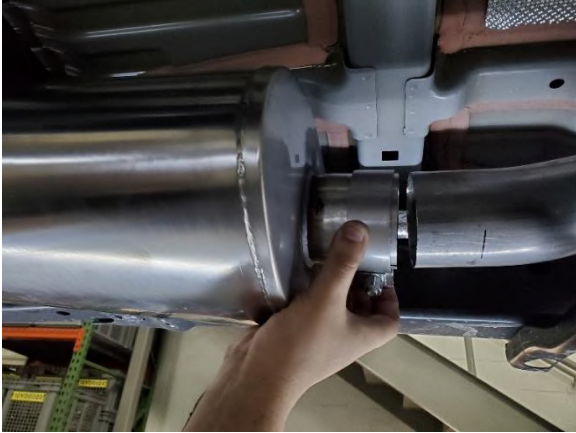

2. Locate muffler assembly and one 3" clamp.



3. Slide muffler assembly onto headpipe outlet with 3" clamp and snug clamp with 15mm socket and ratchet, supporting outlet end of muffler.



4. Locate mid pipe assembly for sport exhaust or pack muffler assembly for touring exhaust and one 3" clamp. Slide hanger into rubber isolator.

NOTE: The use of a soap and water solution may ease the installation of hanger.

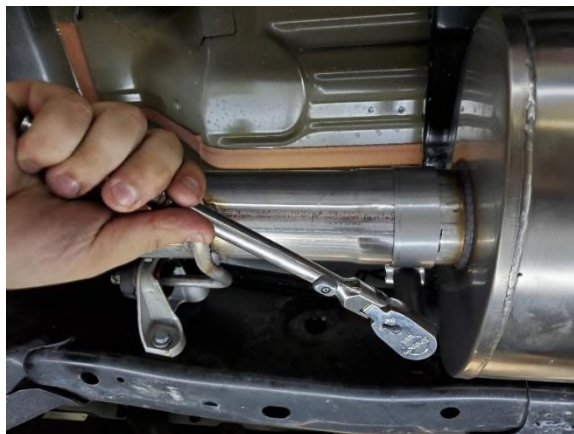

5. Slide midpipe inlet onto outlet of muffler and snug clamp using a 15mm socket and ratchet.

Continued on Next Page ...

INSTALLATION INSTRUCTIONS

CORSA EXHAUST



DUMP VERSION



Single Side Exit

- 6.** Locate the tailpipe assembly and the rear rubber isolator mounting bracket from removal step 6 or 11 depending on removal method. Install rubber isolator onto rear hanger of tailpipe.

NOTE: The use of a soap and water solution may ease the installation of hanger into rubber isolator.



- 7.** Feed the tailpipe assembly over the axle from the rear of the vehicle. Insert the hanger into the rubber isolator.

NOTE: The use of a soap and water solution may ease the installation of hanger into rubber isolator.



- 8.** Locate one 3" clamp and place it on the inlet of the tailpipe. Insert the outlet of the midpipe into the inlet of the tailpipe.

Continued on Next Page . . .

INSTALLATION INSTRUCTIONS

CORSA EXHAUST



Dump Version

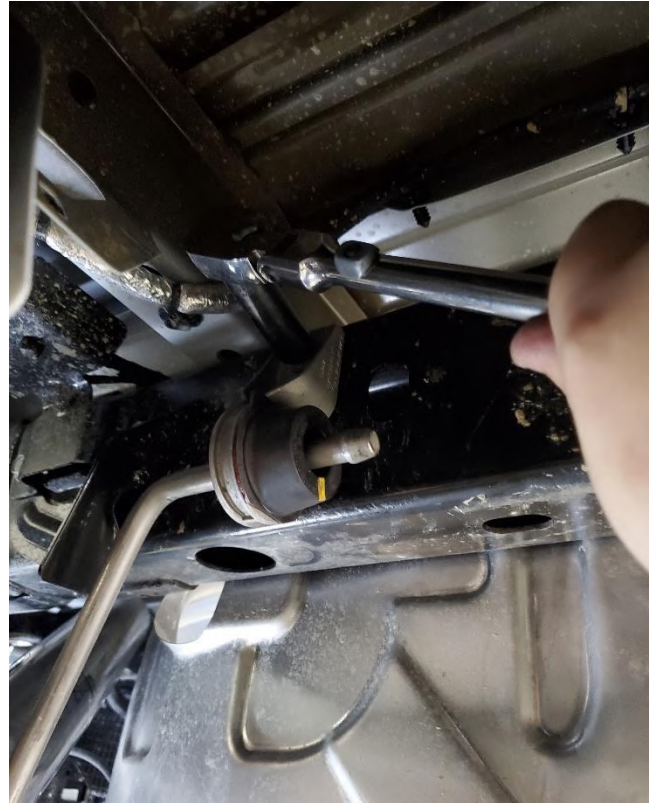

Single Side Exit

- 9.** Secure the rubber isolator mounting bracket to its factory location using the hardware from removal step 6 or 10. Tighten the bracket hardware using a 13mm socket and ratchet.



- 10.** Tighten the clamp connecting the tailpipe to the mid pipe assembly using a ratchet and 15mm socket until the tailpipe is snug on the mid pipe.



- 11.** For Single Side Exit systems, locate tip assembly and 3" clamp. Slide tip assembly onto tailpipe along with clamp and position tip to desired etch reveal.

- 12.** Moving from the front of the vehicle to the rear, ensure there is sufficient clearance to all components and tighten all clamps to 45 ft/lbs using torque wrench and 13mm socket for front clamp and 15mm socket for remaining clamps.

Step 12 completes the installation of your CORSA Exhaust System

2020 Jeep Gladiator 3.6L
3.0" Cat-Back Exhaust
Part #: 21060(BLK), 21061, 21062(BLK), 21063



NOTE: During cold weather start-ups, you may experience an exhaust sound that is deeper and louder in tone than usual. This is temporary and will diminish to normal levels once your engine has reached its normal operating temperature.

NOTE: Immediately following the installation of your exhaust system, you may experience a trace of smoke after initial start-up. DO NOT be alarmed. The smoke is caused by the burning of a small amount of forming oil residue used in the manufacturing process.

NOTE: It is strongly suggested that all clamps be checked and tightened after road testing the vehicle once the system has cooled.