

****DO NOT EXCEED RECOMMENDED VEHICLE TOWING WEIGHT!****

C-659 SUBKIT

'02-'08 DODGE 1/2 TON TRUCKS
'03-'12 DODGE 3/4 & 1 TON TRUCKS
(WILL FIT 1/2, 3/4 & 1 TON MEGA CAB SHORT BED)

WARNING!!

BRAKE, FUEL, AND ELECTRICAL LINES MAY NEED TO BE LOOSENED OR REPOSITIONED TO PROVIDE CLEARANCE FOR NEW HARDWARE. ALL MODELS REQUIRE MODIFICATION OR REMOVAL OF HEAT SHIELDS. ON SHORT BED MODELS, CHECK FOR ADEQUATE TURNING CLEARANCE BETWEEN THE FRONT OF ALL TRAILERS AND THE TRUCK CAB.

When placing the U-bolt against the frame stay under the wiring harness and brake line. Make certain that nothing is between the U-bolt and frame before attaching to the side plate. If needed, a brake line spacer is in the bolt kit and can be used to clamp the U-bolt over the top of the brake line when installed as shown in Figure 4.

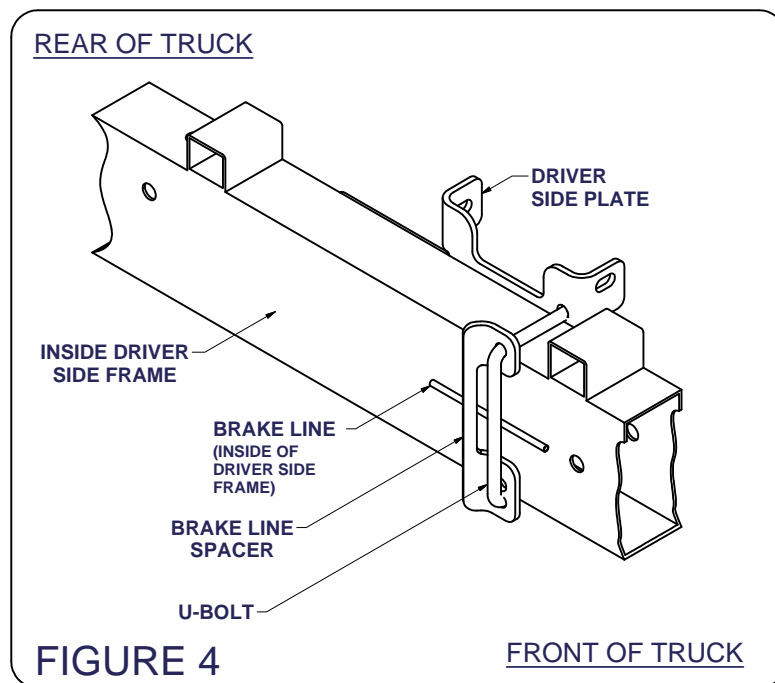

Curt Manufacturing Inc., warrants this product to be free of defects in material and/or workmanship at the time of retail purchase by the original purchaser. If the product is found to be defective, Curt Manufacturing Inc., may repair or replace the product, at their option, when the product is returned, prepaid, with proof of purchase. Alteration to, misuse of, or improper installation of this product voids the warranty. Curt Manufacturing Inc.'s liability is limited to repair or replacement of products found to be defective, and specifically excludes liability for incidental or consequential loss or damage.

****DO NOT EXCEED RECOMMENDED VEHICLE TOWING WEIGHT!****

C-659 SUBKIT

'02-'08 DODGE 1/2 TON TRUCKS
'03-'12 DODGE 3/4 & 1 TON TRUCKS
(WILL FIT 1/2, 3/4 & 1 TON MEGA CAB SHORT BED)

10/15/2013

WARNING!! BRAKE, FUEL, AND ELECTRICAL LINES MAY NEED TO BE LOOSENED OR REPOSITIONED TO PROVIDE CLEARANCE FOR NEW HARDWARE. ALL MODELS REQUIRE MODIFICATION OR REMOVAL OF HEAT SHIELDS. ON SHORT BED MODELS, CHECK FOR ADEQUATE TURNING CLEARANCE BETWEEN THE FRONT OF ALL TRAILERS AND THE TRUCK CAB.

INSTALLATION STEPS

WARNING!! ON TWO WHEEL DRIVE TRUCKS A CLEARANCE CHECK MUST BE PERFORMED WHEN TRUCK IS LOADED AND UNLOADED TO VERIFY THE INVERTED BALL WILL NOT INTERFERE WITH THE TOP OF THE DIFFERENTIAL

BEFORE INSTALLING

An overhead lifting device, such as chain falls, engine hoist, or cable come-a-long, can be used to lift the center section of the hitch in place. Lower a loop of rope or chain through the hole in the truck bed floor and attach it to the round hitch receiver tube in the center section. Use the lifting device to raise the center section until the round hitch receiver tube that protrudes from the center section fits in the hole in the truck bed floor. Maintaining upward pressure may facilitate fastening the cross-member to the center section, especially if the truck bed floor has been distorted downward from heavy use. If you use an overhead-lifting device, it should be disconnected before squaring the center section across the frame, installing the sideplates and torquing fasteners.

- 1) Mark the location for the hole in the truck bed. Measure from the tailgate end of the truck bed, by hooking a tape measure over the **back of the truck box** and marking the correct location. (**NOTE: DO NOT MEASURE FROM EDGE OF TAILGATE**) Next, mark the center between the wheel wells. This marks the center point for the drill hole. This hole location is critical for the correct installation of this hitch. Measure, mark, and saw carefully. This location will put the ball 4"-5" in front of the axle.

Short Bed Installation 45 1/2"
Long Bed Installation 47 1/2"

NOTE: If truck has a plastic bed liner, you may drill through both, but it is more difficult to accurately locate the midpoint between the wheel wells, and to keep the bed liner from moving while cutting the hole. Make a 4" (3 5/8" for C-630/C-640) hole at this location using a 4" (or 3 5/8") hole saw, or by making a 4" (or 3 5/8") circle and cutting it out with a saber saw equipped with a metal cutting blade.

- 2) The exhaust **must** be lowered on **Mega Cab & 1/2 ton applications**. Remove the rear most exhaust bracket and replace it with the exhaust bracket supplied in the bolt kit. When installing the provided bracket, use the lower most hole. This will drop the exhaust and provide clearance for the cross arm installation on the Mega Cab, and the clearance needed to insert the 5/8" x 7 3/4" bolt through the bottom of the frame on 1/2 ton applications. Next, install the two cross arms by sliding them through the wheel well, above the tire on the passenger side of the truck, between the truck frame and truck bed. Slide through until the cross arms are sitting on the truck frames. The gap between the bed and frame is large enough to allow this, but is partially obstructed by an approximate 1" of sheet metal flange that is hanging down from the bed. Notch the flange on the passenger side of the truck. Locate the 7/16" hole in the flange above the axle and remove the metal below the hole. (As shown in **Figure 1**) This notch allows for the rear cross arm installation.

1" BED FLOOR FLANGE IN PASSENGER SIDE WHEEL WELL

APPROX. CUT LINE

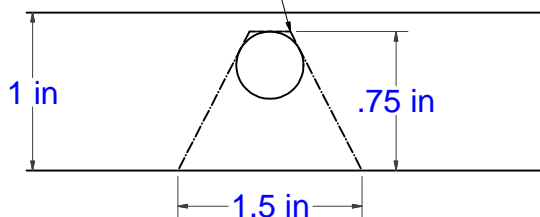

FIGURE 1

FRONT OF TRUCK

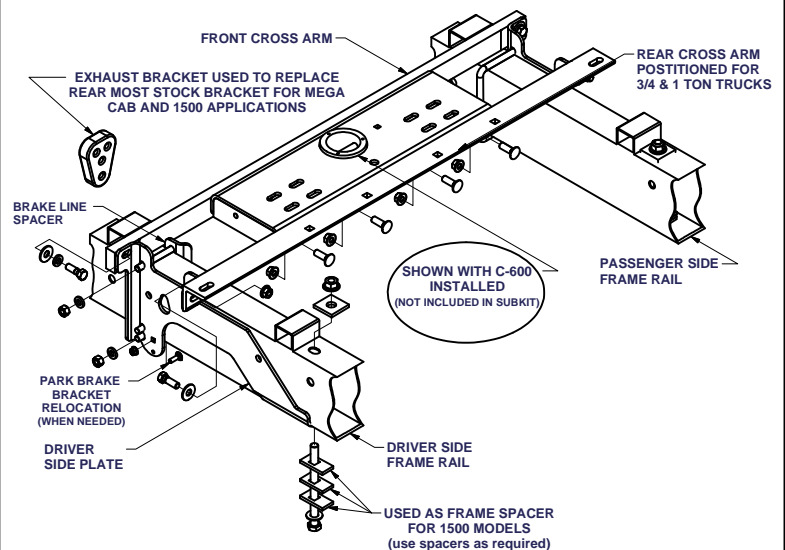

FIGURE 2

REAR OF TRUCK

Curt Manufacturing Inc., warrants this product to be free of defects in material and/or workmanship at the time of retail purchase by the original purchaser. If the product is found to be defective, Curt Manufacturing Inc., may repair or replace the product, at their option, when the product is returned, prepaid, with proof of purchase. Alteration to, misuse of, or improper installation of this product voids the warranty. Curt Manufacturing Inc.'s liability is limited to repair or replacement of products found to be defective, and specifically excludes liability for incidental or consequential loss or damage.

C-659 SUBKIT

'02-'08 DODGE 1/2 TON TRUCKS
'03-'12 DODGE 3/4 & 1 TON TRUCKS
(WILL FIT 1/2, 3/4 & 1 TON MEGA CAB SHORT BED)

Installation Steps Continued

- 3) Install the front cross arm by sliding it between the truck frame and truck bed above the passenger side rear tire. Slide through until both sides are resting on the truck frame. Rotate the cross arm so that it sits in the vertical position with the outer most holes toward the top of the cross arm. Slide the arm forward to the truck bed support.
- 4) Install the rear cross arm using the clearance notch with the angle oriented in an inverted V position. **On 2006 and newer 1/2 ton models**, the angle leg with the notches should face the front of the truck when installing through the notch. Slide the cross arm through until it is resting on the truck frame on both sides. Push the rear cross arm towards the back of the truck against the truck bed rail, then rotate it so that the leg against the bed frame is facing the rear of the truck. (As shown in **Figure 2**)
- 5) Raise the center section in position between the cross arms **with the center hole towards the front of truck**. The round hitch receiver that protrudes from the top of the center section must fit through the hole in the truck bed. Using (4) 1/2" bolts, washers, and lock washers, attach the center section to the threaded holes in the front cross arm. Next, attach the rear cross arm (angle iron) to the center section using (4) 1/2" carriage bolts and flange nuts. (**Finger tight only**.)
- 6) Remove the emergency brake cable bracket on the driver side frame if the brake cable interferes. This will be reattached to the side plate at a later time.
- 7) Square the center section and cross arms across the frame. Thread a 1 1/2" bolt with a flat and lock washer through the front flange of the sideplate into the front cross arm. Place a 1 1/2" bolt with a flat washer through the back flange of the sideplate into the rear cross arm. (As shown in **Figure 2**) **Finger tight** with a 1/2" flange nut. (**REPEAT FOR OTHER SIDE.**)
- 8) Insert a 5/16" x 1" carriage bolt through the driver side plate with the threads facing out. Reattach the parking brake cable bracket to the bolt and side plate if needed. Next, install the U-bolts from inside the frame through the holes in the side plates. On the driver side, it is necessary to remove a wiring harness frame clip. Place the U-bolt against the frame staying under the wiring harness and brake line. Make certain that nothing is between the U-bolt and frame before attaching to the side plate. If needed, a brake line spacer is in the bolt kit and can be used to clamp the U-bolt over the top of the brake line when installed as shown in **Figure 3**. Replace the wiring harness frame clip and fasten the U-bolt to the side plates using a 1/2" lock washer and a 1/2" flange nut to each end of the U-bolt. (**Finger tight only**) Next, attach rear end of side plates to the truck frame by inserting the 5/8" x 7 3/4" hex bolt through the hole in the side plate that wraps under the frame. Push the hex bolt up through the frame with a 5/8" washer on it and attach it to the top of the frame with a CM-SP24 spacer and a 5/8" nut.
For 1/2 ton applications, place the 5/8" x 7 3/4" hex bolt through the bottom sideplate flange and clamp three CM-SP9 spacers between the sideplate and frame. Attach it to the top of the frame with a CM-SP24 spacer and a 5/8" nut. While installing on the passenger side, pull the exhaust sideways to allow ample clearance for the 7 3/4" hex bolt installation.
- 9) With the sideplates installed on both sides, torque all 1/2" fasteners to 110 ft.-lbs. and 5/8" fasteners to 210 ft.-lbs. in the following order:
First: Torque the center section to the front and rear cross arms.
Second: Torque the sideplates to the truck frame on both sides.
Third: Torque the sideplate flanges to the front and rear cross arms.

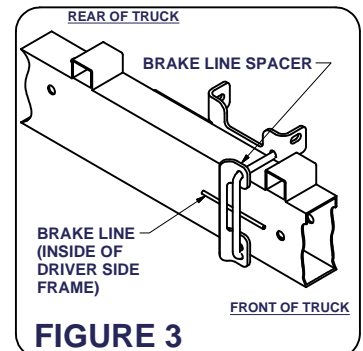

FIGURE 3

(REFER TO GOOSENECK HITCH INSTRUCTIONS FOR INSTALLATION AND OPERATION PROCEDURES)

Maintenance (Required every 30 days or prior to use)

1. Keep hitch ball lubricated regularly. Use silicone spray or equivalent to prevent wear and rust.
2. Keep hitch assembly free of dirt and other foreign debris.
3. Check for proper torque on all nuts and bolts before each use. Also check for excessive wear.
4. Check ball wear before each use. (**Note: Do not tow trailer with worn or damaged parts.**)

C-659 SUBKIT

'02-'08 DODGE 1/2 TON TRUCKS
'03-'12 DODGE 3/4 & 1 TON TRUCKS
(WILL FIT 1/2, 3/4 & 1 TON MEGA CAB SHORT BED)

Parts List			
ITEM	QTY	PART NUMBER	DESCRIPTION
1	2	CM-1204-UBS	1/2-13 x 4 1/4 x 6 7/8 x 1 1/2 SQ U-BOLT
2	8	1/2 - 13 x 1 1/2	HEX BOLT
3	8	FW12	FW, 12, ZP
4	6	HFN 1213	HEX FLANGE NUT
5	4	1/2-13 x 1 1/2	CARRIAGE BOLT
6	1	5/16-18 x 1	CARRIAGE BOLT
7	1	5/16-18	HEX FLANGE NUT
8	10	1/2"	LOCK WASHER
9	4	1_2 - 13 HEX NUT GR8	HEX NUT
10	2	5_8 - 11 x 7 3_4 HEX	HEX BOLT
11	2	5/8-11	HEX FLANGE NUT
12	2	5/8	WASHER
13	2	CM-1205-UBS	1/2-13 x 4 1/4 x 6 1/8 x 1 1/2 SQ U-BOLT
14	1	CM-C655-EH	EXHAUST HANGER
15	1	CM-C659-BLS	1/4" BRAKE LINE SPACER
16	2	CM-SP24	.250 x 2.00 x 2.00" ROUND HOLE SPACER
17	6	CM-SP9	.250 x 1.25 x 2.50" SQUARE HOLE SPACER

REAR OF TRUCK

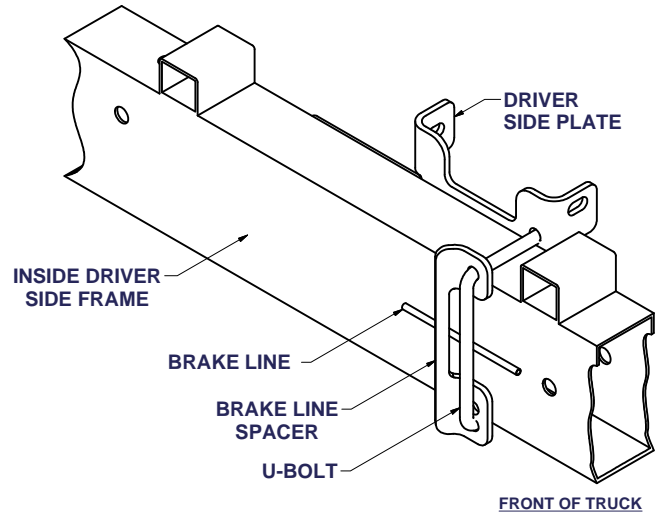

FRONT OF TRUCK

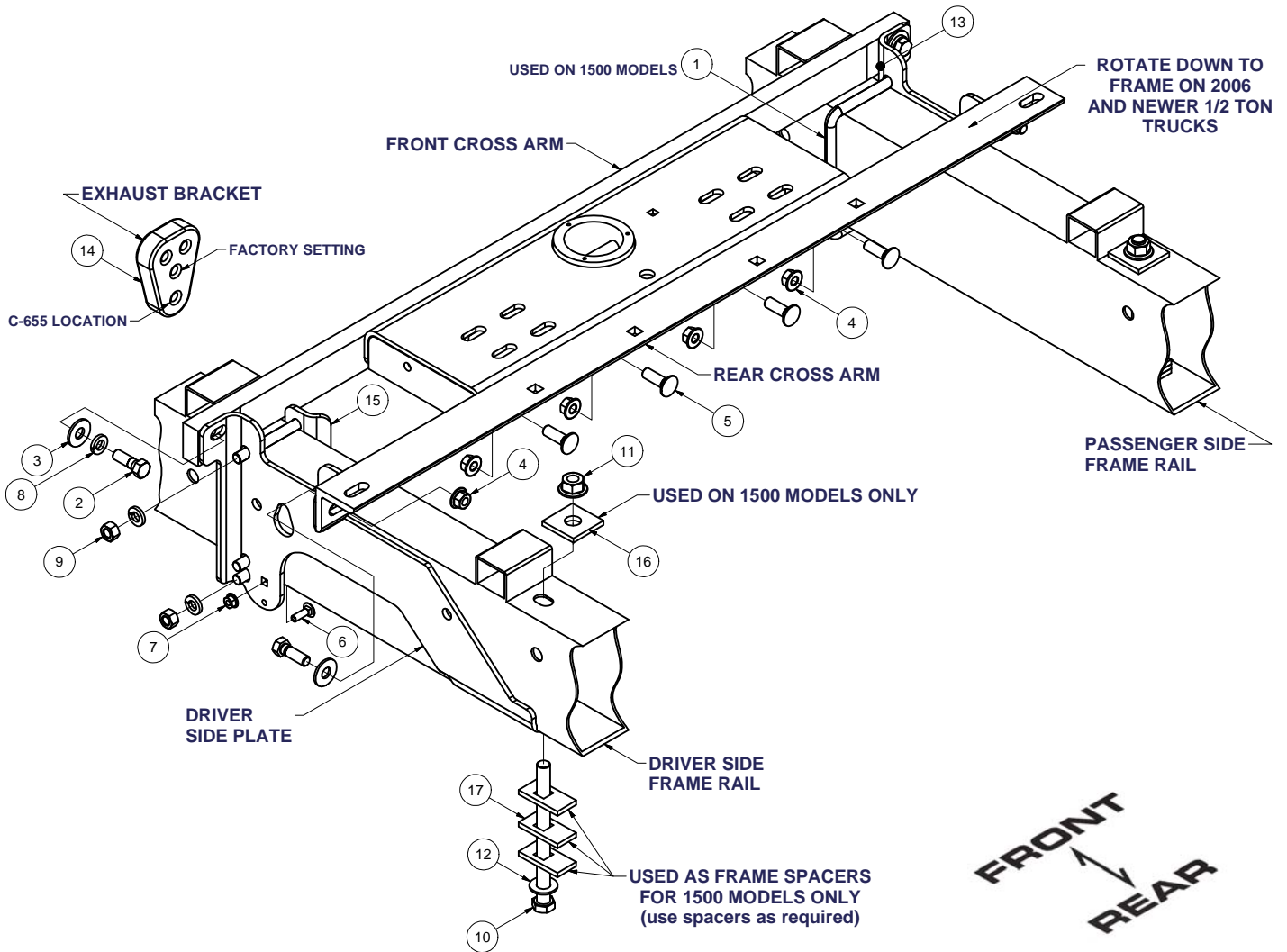

PERIODICALLY CHECK THIS RECEIVER HITCH TO ENSURE THAT ALL FASTENERS ARE TIGHT AND THAT ALL STRUCTURAL COMPONENTS ARE SOUND.

Curt Manufacturing Inc., warrants this product to be free of defects in material and/or workmanship at the time of retail purchase by the original purchaser. If the product is found to be defective, Curt Manufacturing Inc., may repair or replace the product, at their option, when the product is returned, prepaid, with proof of purchase. Alteration to, misuse of, or improper installation of this product voids the warranty. Curt Manufacturing Inc.'s liability is limited to repair or replacement of products found to be defective, and specifically excludes liability for incidental or consequential loss or damage.

C-659 SUBKIT

'02-'08 DODGE 1/2 TON TRUCKS
'03-'12 DODGE 3/4 & 1 TON TRUCKS
 (WILL FIT 1/2, 3/4 & 1 TON MEGA CAB SHORT BED)

****REMOVAL OF REAR WINDOW ACCESSORIES MAY BE REQUIRED.****

TRAILER

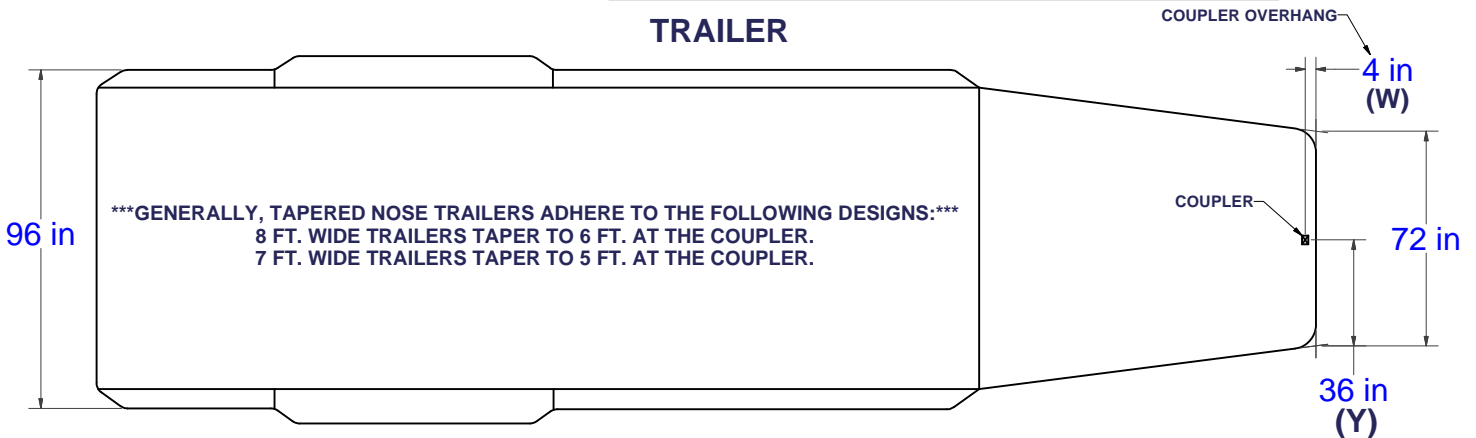

GENERALLY, TAPERED NOSE TRAILERS ADHERE TO THE FOLLOWING DESIGNS:
 8 FT. WIDE TRAILERS TAPER TO 6 FT. AT THE COUPLER.
 7 FT. WIDE TRAILERS TAPER TO 5 FT. AT THE COUPLER.

LONG & SHORT TRUCK BEDS

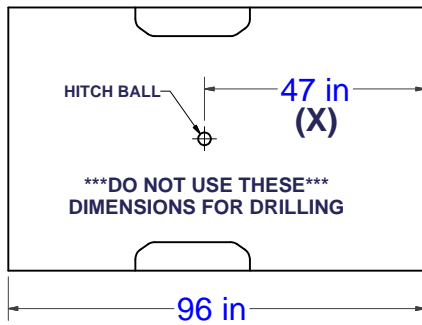

CAB OF TRUCK

DO NOT USE THESE
 DIMENSIONS FOR DRILLING

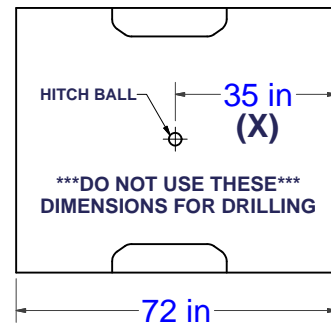

CAB OF TRUCK

DO NOT USE THESE
 DIMENSIONS FOR DRILLING

CLEARANCE CALCULATION

(CAB TO BALL CENTER) - 1/2 (TRAILER WIDTH) = (MINIMUM CLEARANCE)
 (X) - (Y) = (Z)

IF THERE IS AN OVERHANG FROM THE COUPLER THEN THE EQUATION IS:
 [(X) - (W)] - (Y) = (Z)

IF (Z) IS POSITIVE, TRAILER **WILL NOT** INTERFERE WITH CAB OF TRUCK.
 IF (Z) IS NEGATIVE, TRAILER **WILL** INTERFERE WITH CAB OF TRUCK!!!

EXAMPLE:

STANDARD TRAILER

X - Y = Z
 35 - 36 = -1
 (TRAILER **WILL INTERFERE** WITH CAB)

TRAILER WITH OVERHANG

[(X) - (W)] - Y = Z
 [35 - 4] - 36 = -5
 (TRAILER **WILL INTERFERE** WITH CAB)

YOUR CALCULATION:

(CAB TO BALL CENTER) _____
 (COUPLER OVERHANG) - _____
 1/2 (TRAILER WIDTH) - _____
 (MINIMUM CLEARANCE) = _____

Curt Manufacturing Inc., warrants this product to be free of defects in material and/or workmanship at the time of retail purchase by the original purchaser. If the product is found to be defective, Curt Manufacturing Inc., may repair or replace the product, at their option, when the product is returned, prepaid, with proof of purchase. Alteration to, misuse of, or improper installation of this product voids the warranty. Curt Manufacturing Inc.'s liability is limited to repair or replacement of products found to be defective, and specifically excludes liability for incidental or consequential loss or damage.