

**\*\*DO NOT EXCEED RECOMMENDED VEHICLE TOWING WEIGHT!\*\***

## 60644 SUBKIT

**99-CURRENT FORD 3/4 & 1 TON SUPER DUTY, 08' F-450  
(WITH OR WITHOUT AFTERMARKET AIR BAG OVERLOADS)**

**10/3/2017** WARNING!! BRAKE, FUEL, AND ELECTRICAL LINES MAY NEED TO BE LOOSENED OR REPOSITIONED TO PROVIDE CLEARANCE FOR NEW HARDWARE. ALL MODELS REQUIRE MODIFICATION OR REMOVAL OF HEAT SHIELDS. ON SHORT BED MODELS, CHECK FOR ADEQUATE TURNING CLEARANCE. BETWEEN THE FRONT OF ALL TRAILERS AND THE TRUCK CAB.

WARNING!! ON TWO WHEEL DRIVE TRUCKS A CLEARANCE CHECK MUST BE PERFORMED WHEN TRUCK IS LOADED AND UNLOADED TO VERIFY THE INVERTED BALL WILL NOT INTERFERE WITH THE TOP OF THE DIFFERENTIAL

### BEFORE INSTALLING

For ease of installation the use of Curt Part # C-606 (Gooseneck Install Tool) is recommended. A lifting device, such as an engine hoist, or cable come-a-long can also be used to lift the center section of the hitch into place. Use of one of these tools will be especially helpful if the truck bed has been distorted downward from heavy use. After the hole is drilled in the truck bed the rope or chain loop can be lowered through the drilled hole and attached to the center of the gooseneck hitch. The gooseneck can then be raised so that the center ring protrudes through the bed floor. Maintaining the upward pressure from the lifting device onto the gooseneck hitch will ease the process of attaching the gooseneck center section to the crossarms. Remove lifting device before torquing hardware.

1. Mark the location for the hole in the truck bed. Measure from the tail gate end of the truck bed. Do this by hooking a tape measure over the back of the truck box and marking the correct location. (NOTE: DO NOT MEASURE FROM EDGE OF TAILGATE) Next, mark the center between the wheel wells. This marks the center point for the drill hole. This hole location is critical for the correct installation of this hitch. Measure, mark, and saw carefully. This location will put the ball 4"- 6" in front of the axle.

#### 1999-2010 MODELS:

LONG AND SHORT BED = **48 1/4"**

(CENTER CYLINDER IN GOOSENECK OFFSET TOWARDS **FRONT** OF VEHICLE)

#### 2011 TO CURRENT MODELS:

LONG AND SHORT BED = **46"**

(CENTER CYLINDER IN GOOSENECK OFFSET TOWARDS **REAR** OF VEHICLE)

#### \*\*IMPORTANT NOTE\*\*

If truck bed has spray on bed liner, add 1/8" to 3/16" when measuring location of center hole.

NOTE: If truck has a plastic bed liner, you may drill through both, but it is more difficult to accurately locate the midpoint between the wells, and to keep the bed liner from moving while cutting the hole. Make a 4"(3 5/8" for the C-640) hole at this location using a 4"(or 3 5/8") hole saw or by making a 4"(or 3 5/8") circle and cutting it out with a saber saw equipped with a metal cutting blade.

2. The exhaust will need to be lowered on 2005 and newer trucks equipped with a diesel engine. First remove the exhaust hanger located behind the rear tire on the passenger side. This will be re-installed later.
3. Remove the heat shield which is located under the truck bed above the rear axle.
4. On 2004 and older trucks, the emergency brake cable located on the outside of the driver's side frame will need to be relocated. Knock the mounting stud out of the frame with a hammer and punch and discard. A 5/16" relocating bolt is included in the kit and will be installed after the sideplates are installed.

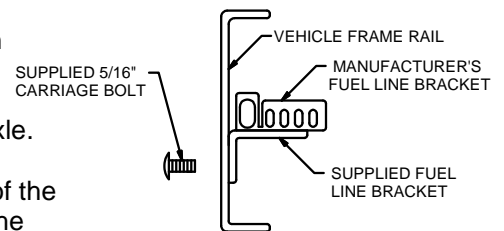

FIGURE A

On gasoline engine trucks, it may be necessary to relocate a fuel line bracket. If the oval hole in the driver's side frame just above the axle is partially blocked, you will need to relocate the bracket blocking the oval by removing the bracket from the frame, rotating it 90°, then installing the supplied fuel line bracket in the bolt kit with a 5/16" carriage bolt. See **FIGURE A**

5. Some truck models will allow the crossarms to slide between the frame and bed without modification. If this is not possible, cut a small notch in the flange on driver's side of the truck as shown in **FIGURE B**. Locate the front bed crossmember in the wheel well and measure back from that.

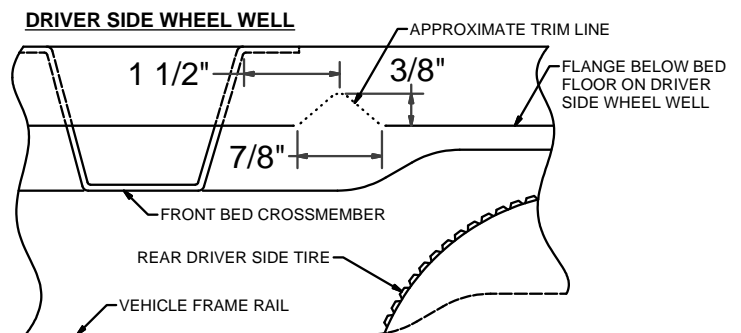

FIGURE B

**\*\*DO NOT EXCEED RECOMMENDED VEHICLE TOWING WEIGHT!\*\***

## 60644 SUBKIT

**99-CURRENT FORD 3/4 & 1 TON SUPER DUTY, 08' F-450  
(WITH OR WITHOUT AFTERMARKET AIR BAG OVERLOADS)**

**WARNING!!** BRAKE, FUEL, AND ELECTRICAL LINES MAY NEED TO BE LOOSENED OR REPOSITIONED TO PROVIDE CLEARANCE FOR NEW HARDWARE. ALL MODELS REQUIRE MODIFICATION OR REMOVAL OF HEAT SHIELDS. ON SHORT BED MODELS, CHECK FOR ADEQUATE TURNING CLEARANCE BETWEEN THE FRONT OF ALL TRAILERS AND THE TRUCK CAB.

Parts List			
ITEM	QTY	PART NUMBER	DESCRIPTION
1	1	CM-60644-FLB	.125" FUEL LINE BRACKET
2	3	5/16-18 x 1	CARRIAGE BOLT
3	3	5/16-18	HEX FLANGE NUT
4	12	1/2-13 x 1 1/2	CARRIAGE BOLT
5	4	1/2 - 13 x 1 1/2	HEX BOLT
6	4	1/2 CONICAL TOOTHED WASHER	WASHER, CONICAL, TOOTHED, 1/2"
7	19	HFN 1213	HEX FLANGE NUT
8	1	CM-1213-UBS	1/2-13 x 3 3/4 x 7 5/8 x 2 SQ U-BOLT
9	2	3_4 - 10 x 2 1/2 HEX	HEX HEAD BOLT-NC
10	2	3_4 FW	FLAT WASHER
11	2	3_4 - 10 HFN	HEX FLANGE NUT

### FRONT OF TRUCK

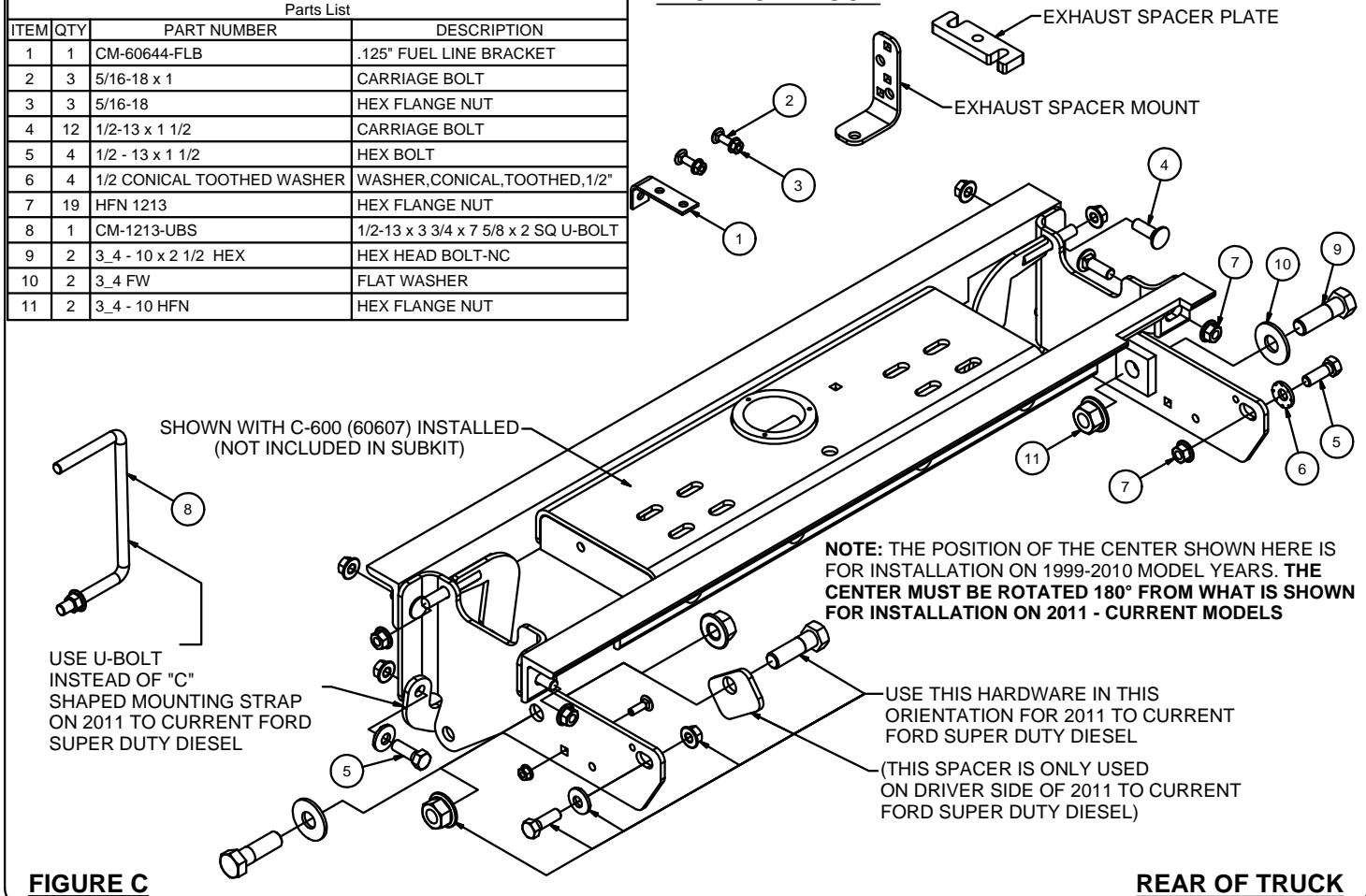

### Installation Steps Continued

6. Install the rear crossarm (it has three notches). Slide the crossarm between the frame and bed on the driver's side. If needed, use the notch cut out in Step 5. Make sure the leg of the angle with the oval holes is facing toward the cab and slide the angle through until it rests on both frame rails. Next, using the notch over the shock bracket for clearance, roll the angle iron over the bracket while sliding it toward the rear. Continue to slide it back until it is about four inches behind the four inch hole in the truck bed. Next, install the front crossarm in the same way, except the leg of the angle with the oval holes should face the rear of the truck. Slide it rearward slightly and leave it behind the shock bracket. This will be left there until it is needed for installation.
7. If the emergency brake cable has been removed, place a 5/16" carriage bolt through the small square hole in the driver sideplate, add a 5/16" flange nut loosely to hold in place. (See **FIGURE C** for orientation of bolt) This will be used to attach the emergency brake cable bracket.
8. Install the "C" shaped mounting strap and side plate on the driver side of the truck. Take a mounting strap and position around the frame approximately 6 1/2" in front of the slotted hole in the frame. (A U-Bolt will be used instead of mounting strap on driver side of 2011 to current Ford Super Duty diesel) Next, take the sideplate and slide the bottom side between the frame and the bottom of the mounting strap. Guide the stud through the hole in the plate and attach loosely with a 1/2" flange nut. Place a 1/2" bolt with a conical toothed washer through the bottom of the mounting strap and hole in the sideplate as shown in **FIGURE C** and attach loosely with 1/2" flange nut. Next, install 3/4" bolt and washer through hole in sideplate then through the slot in the frame. Attach on backside of frame with a 3/4" flange nut. See **FIGURE C** for the orientation of hardware for 2011 to current Ford to present Super Duty Diesel (It only varies on the driver side of this vehicle) and the location of other hardware. Leave all hardware loose. Repeat process for passenger side.

Curt Manufacturing Inc., warrants this product to be free of defects in material or workmanship at the time of retail purchase by the original purchaser. If the product is found to be defective, Curt Manufacturing Inc., may repair or replace the product, at their option, when the product is returned, prepaid, with proof of purchase. Alteration to, misuse of, or improper installation of this product voids the warrant. Curt Manufacturing Inc.'s liability is limited to repair or replacement of products found to be defective, and specifically excludes liability for incidental or consequential loss or damage.

**\*\*DO NOT EXCEED RECOMMENDED VEHICLE TOWING WEIGHT!\*\***

## 60644 SUBKIT

**99-CURRENT FORD 3/4 & 1 TON SUPER DUTY, 08' F-450  
(WITH OR WITHOUT AFTERMARKET AIR BAG OVERLOADS)**

- Raise the center section in to position between the cross arms. The ball cylinder that protrudes from the top of the center section must fit through the hole in the truck bed. Using (4) 1/2" carriage bolts and flange nuts, attach the center section to the square holes in the front crossarm. Next, attach the rear crossarm to the center section using (4) 1/2" carriage bolts and flange nuts. (Finger tighten only) Finally, bolt the sideplates to the crossarms using 1/2" bolts, washers, and flange nuts. **On 2011 to current models the cylinder in the center section needs to be rotated towards the back of bed.**
- With the sideplates installed on both sides, torque all 3/4" fasteners to 380 ft.-lbs. and 1/2" fasteners to 110 ft.-lbs, in the following order:  
**First:** Torque the center section to the front and rear crossarms.  
**Second:** Torque the side plates to the truck frame on both sides. **(When torquing the U-bolts, make sure to tighten them slowly alternating between the top and bottom of the U-bolt until equally tightened to maximum of 40 ft.-lbs.)**  
**Third:** Torque the side plates to the front and rear crossarms.
- Re-attach exhaust hanger. On 2005 - current Ford Super Duty trucks with diesel engines the exhaust will have to be lowered slightly. There are two types of factory tail pipe mounts on the Super Duty. One uses a single bolt through the side of the frame while the other uses two bolts, one through the side of the frame and one through the bottom of the frame. Both factory mounts can be lowered with the use of the supplied exhaust spacer mount. **(Refer to FIGURE D and E below)** 2008 - current Ford Super Duty trucks with diesel engines will need the supplied exhaust spacer plate added to the center exhaust hanger. **(Refer to FIGURE F and G below)**

### **2005 - CURRENT MODEL TRUCK WITH DIESEL ENGINE**

On 2005 to current Ford Super Duty with a diesel engine, the exhaust will have to be lower at the rear exhaust bracket to allow clearance for the Turnover Ball Gooseneck Hitch. See **FIGURE D AND E.**

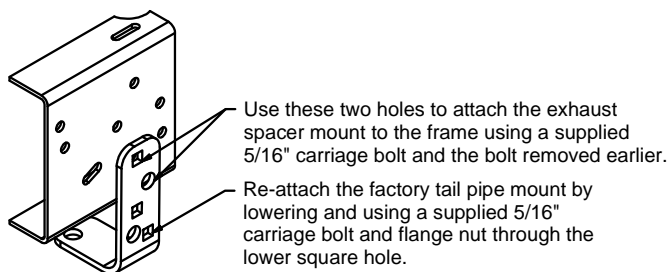

**FIGURE D** (EXHAUST MOUNTS WITH ONE BOLT)

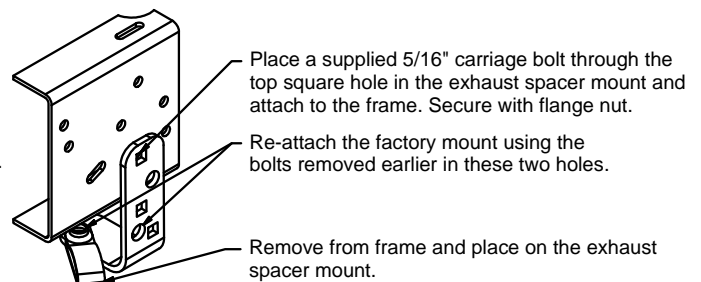

**FIGURE E** (EXHAUST MOUNTS WITH TWO BOLTS)

### **2008 TO CURRENT MODEL TRUCK WITH DIESEL ENGINE**

Re-positioning the exhaust at this location will allow adequate clearance around the exhaust pipe and improve ground clearance at the end of the tail pipe. Use a deep well socket to loosen nuts on top of crossmember. Insert the supplied exhaust spacer plate and tighten nuts. See **FIGURE F AND G.**

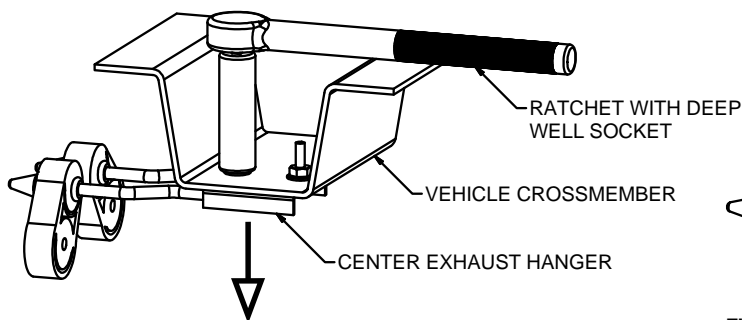

**FIGURE F**

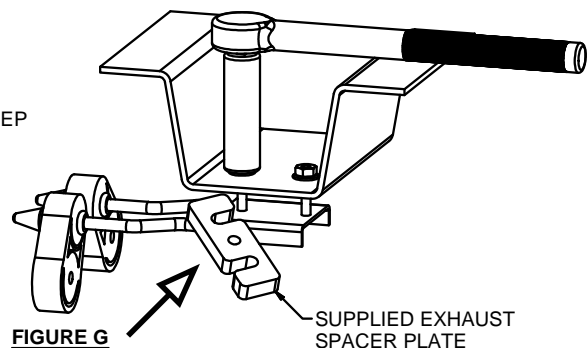

**FIGURE G**

(REFER TO GOOSENECK HITCH INSTRUCTIONS FOR INSTALLATION AND OPERATING PROCEDURES)

Maintenance (Required every 30 days or prior to use)

- Keep hitch ball lubricated regularly. Use silicone spray or equivalent to prevent wear and rust.
- Keep hitch assembly free of dirt and other foreign debris.
- Check for proper torque on all nuts and bolts before each use. Also check for excessive wear.
- Check for ball wear before each use. (Note: Do not tow trailer with worn or damaged parts)

Curt Manufacturing Inc., warrants this product to be free of defects in material and/or workmanship at the time of retail purchase by the original purchaser. If the product is found to be defective, Curt Manufacturing Inc., may repair or replace the product, at their option, when the product is returned, prepaid, with proof of purchase. Alteration to, misuse of, or improper installation of this product voids the warranty. Curt Manufacturing Inc.'s liability is limited to repair or replacement of products found to be defective, and specifically excludes liability for incidental or consequential loss or damage.

\*\*\*DO NOT EXCEED VEHICLE MANUFACTURER'S RECOMMENDED TOWING CAPACITY.\*\*\*

# CAB TO TRAILER CLEARANCE

\*\*REMOVAL OF REAR WINDOW ACCESSORIES MAY BE REQUIRED.\*\*

## TRAILER

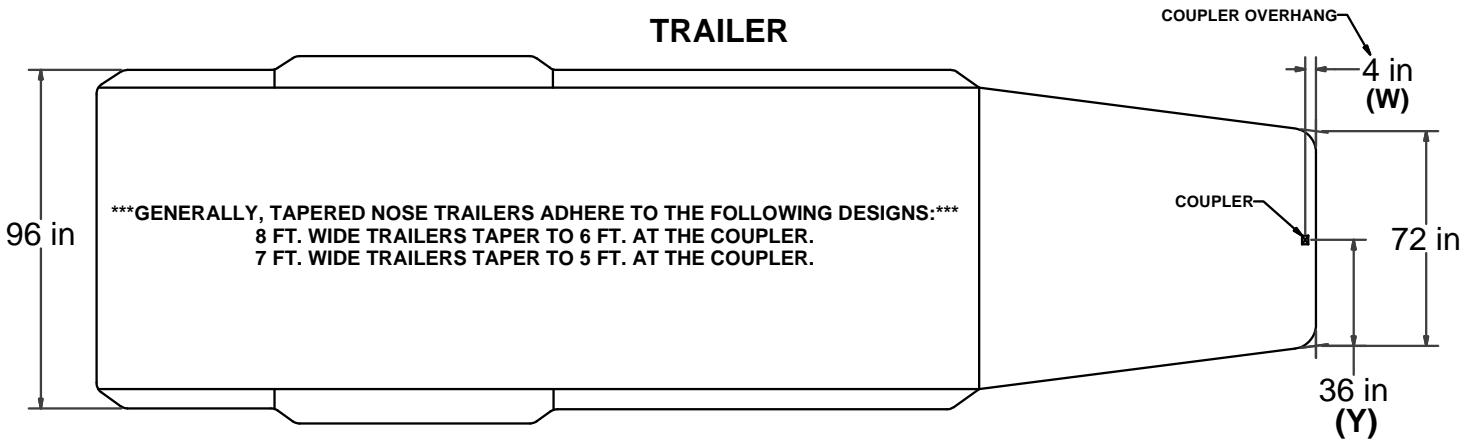

## LONG & SHORT TRUCK BEDS

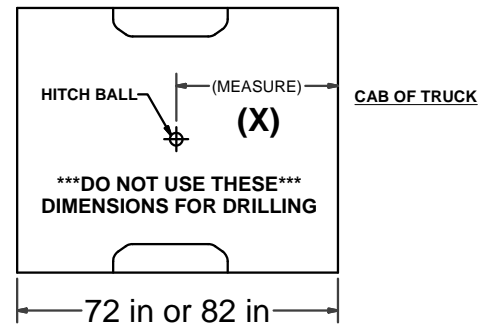
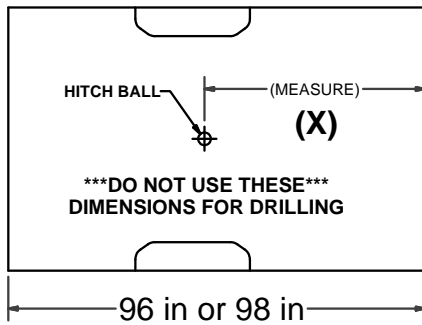

## CLEARANCE CALCULATION

$$\text{(CAB TO BALL CENTER)} - \frac{1}{2} \text{(TRAILER WIDTH)} = \text{(MINIMUM CLEARANCE)}$$

$$(X) - (Y) = (Z)$$

IF THERE IS AN OVERHANG FROM THE COUPLER THEN THE EQUATION IS:

$$[(X) - (W)] - (Y) = (Z)$$

\*\*\*IF (Z) IS POSITIVE, TRAILER **WILL NOT** INTERFERE WITH CAB OF TRUCK.\*\*\*  
 IF (Z) IS NEGATIVE, TRAILER **WILL** INTERFERE WITH CAB OF TRUCK!!!

### EXAMPLE:

#### STANDARD TRAILER

$$X - Y = Z$$

$$35 - 36 = -1$$

(TRAILER **WILL INTERFERE** WITH CAB)

#### TRAILER WITH OVERHANG

$$[(X) - (W)] - Y = Z$$

$$[35 - 4] - 36 = -5$$

(TRAILER **WILL INTERFERE** WITH CAB)

### YOUR CALCULATION:

(CAB TO BALL CENTER) \_\_\_\_\_

(COUPLER OVERHANG) \_\_\_\_\_

1/2 (TRAILER WIDTH) \_\_\_\_\_

(MINIMUM CLEARANCE) \_\_\_\_\_

Curt Manufacturing Inc., warrants this product to be free of defects in material and/or workmanship at the time of retail purchase by the original purchaser. If the product is found to be defective, Curt Manufacturing Inc., may repair or replace the product, at their option, when the product is returned, prepaid, with proof of purchase. Alteration to, misuse of, or improper installation of this product voids the warranty. Curt Manufacturing Inc.'s liability is limited to repair or replacement of products found to be defective, and specifically excludes liability for incidental or consequential loss or damage.