

60641**2004 - CURRENT FORD 1/2 TON TRUCKS******NEW BODY STYLE ONLY, LONG AND SHORT BEDS****

WARNING!! BRAKE, FUEL, AND ELECTRICAL LINES MAY NEED TO BE LOOSENED OR REPOSITIONED TO PROVIDE CLEARANCE FOR NEW HARDWARE. ALL MODELS REQUIRE MODIFICATION OR REMOVAL OF HEAT SHIELDS. ON SHORT BED MODELS, CHECK FOR ADEQUATE TURNING CLEARANCE BETWEEN THE FRONT OF ALL TRAILERS AND THE TRUCK CAB.

WARNING!! ON TWO WHEEL DRIVE TRUCKS A CLEARANCE CHECK MUST BE PERFORMED WHEN TRUCK IS LOADED AND UNLOADED TO VERIFY THE INVERTED BALL WILL NOT INTERFERE WITH THE TOP OF THE DIFFERENTIAL

INSTALLATION STEPS

BEFORE INSTALLING

An overhead lifting device, such as chain falls, engine hoist, or cable come-a-long, can be used to lift the center section of the hitch in place. Lower a loop of rope or chain through the hole in the truck bed floor and attach it to the round hitch receiver tube in the center section. Use the lifting device to raise the center section until the round hitch receiver tube that protrudes from the center section fits in the hole in the truck bed floor. Maintaining upward pressure may facilitate fastening the cross-member to the center section, especially if the truck bed floor has been distorted downward from heavy use. If you use an overhead-lifting device, it should be disconnected before squaring the center section across the frame, installing the sideplates and torquing fasteners.

1. Lower and remove spare tire.
2. Mark the location for the hole in the truck bed. Measure from the tail gate end of the truck bed, by hooking a tape measure over the **back of the truck box** and marking the correct location. **(NOTE: DO NOT MEASURE FROM EDGE OF TAILGATE)** Next, mark the center between the wheel wells. This marks the center point for the drill hole. This hole location is critical for the correct installation of this hitch. Measure, mark, and saw carefully. This location will put the ball 4"-6" in front of the axle.

Short Bed Installation	45 3/8"
Long Bed Installation	45 3/8"

NOTE: If truck has a plastic bed liner, you may drill through both, but it is more difficult to accurately locate the midpoint between the wheel wells, and to keep the bed liner from moving while cutting the hole. Make a 4" (3 5/8" for C-630/C-640) hole at this location using a 4" (or 3 5/8") hole saw, or by making a 4" (or 3 5/8") circle and cutting it out with a saber saw equipped with a metal cutting blade.

3. Install the front cross arm by sliding it between the truck bed and truck frame on the passenger side. Slide through in an inverted V position with the holes of the arm towards the rear of the truck. Slide through until the cross arm spans the truck frame. Push the cross arm towards the front of truck.

U-BOLT INSTALLATION PROCEDURE

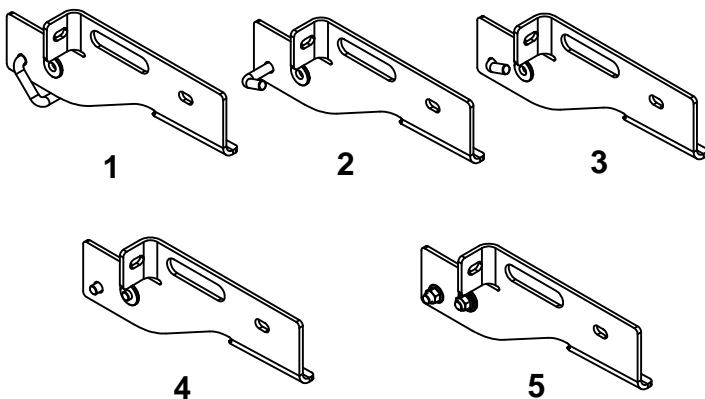
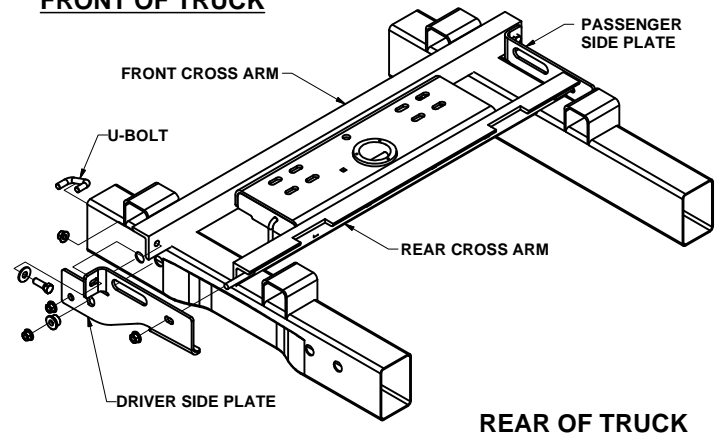

FIGURE 1

FRONT OF TRUCK



REAR OF TRUCK

FIGURE 2

Curt Manufacturing Inc., warrants this product to be free of defects in material or workmanship at the time of retail purchase by the original purchaser. If the product is found to be defective, Curt Manufacturing Inc., may repair or replace the product, at their option, when the product is returned, prepaid, with proof of purchase. Alteration to, misuse of, or improper installation of this product voids the warrant. Curt Manufacturing Inc.'s liability is limited to repair or replacement of products found to be defective, and specifically excludes liability for incidental or consequential loss or damage.

****DO NOT EXCEED RECOMMENDED VEHICLE TOWING WEIGHT!****

C-641 SUBKIT

2004 - CURRENT FORD 1/2 TON TRUCKS

****NEW BODY STYLE ONLY, LONG AND SHORT BEDS****

Installation Steps Continued

WARNING!! BRAKE, FUEL, AND ELECTRICAL LINES MAY NEED TO BE LOOSENED OR REPOSITIONED TO PROVIDE CLEARANCE FOR NEW HARDWARE. ALL MODELS REQUIRE MODIFICATION OR REMOVAL OF HEAT SHIELDS. ON SHORT BED MODELS, CHECK FOR ADEQUATE TURNING CLEARANCE BETWEEN THE FRONT OF ALL TRAILERS AND THE TRUCK CAB.

- Repeat the cross arm installation procedure for the rear cross arm making sure to position the holes in the angle iron towards the front of the truck. After spanning the frame, slide the cross arm towards the rear of the truck.
- Raise the center section in position between the cross arms with the **ball cylinder towards the rear of the truck**. The round hitch receiver that protrudes from the top of the center section must fit through the hole in the truck bed. Using (8) 1/2" carriage bolts and flange nuts, attach the center section to the square holes in both cross arms. **(Finger tight only.)**
- Square the center section and cross arms across the frame. Hang the side plates from the 1/2" studs extending from the rear cross arm. Fasten them with 1/2" flange nuts **finger tight only**. Next, bolt the front flange of the sideplate to the front cross arm using a 1/2" x 1 1/2" hex bolt, 1/2" washer, and 1/2" flange nut as shown in **Figure 2**. The two holes at the front of the sideplates should now be aligned with two holes in the frame behind the shock and shock mount. Use the 2" U-bolt with one flange nut placed loosely to one end of the U-bolt and place the opposite end into the smaller hole at the front of the sideplate and twist through the frame until the threaded end is protruding out the other hole of the sideplate as shown in **Figure 1**. Place the U-bolt bushing over the U-bolt and into the hole of the sideplate and frame. Make sure to penetrate the frame with the bushing in order for the sideplate to rest flat against the frame. Now attach a 1/2" flange nut and **finger tight only**.
- With the sideplates installed on both sides, torque the U-bolt flange nuts to 110 ft.-lbs. and all other 1/2" fasteners to 110 ft.-lbs
in the following order:
First: Torque the U-bolts to the sideplates and frame.
Second: Torque the (8) carriage bolts from the cross arms to the center section.
Third: Torque the side plates to the front and rear cross arms.

Parts List			
ITEM	QTY	PART NUMBER	DESCRIPTION
1	2	CM-1203-UBS	1/2-13 x 1 1/4 x 2 1/2 x 3/4 SQ U-BOLT
2	16	HFN 1213	HEX FLANGE NUT
3	8	1/2-13 x 1 1/2	CARRIAGE BOLT
4	2	1/2 - 13 x 1 1/2	HEX BOLT
5	2	FW12	FW, 12, ZP
6	2	CM-C641-UB	1/2 - 13 U-BOLT BUSHING

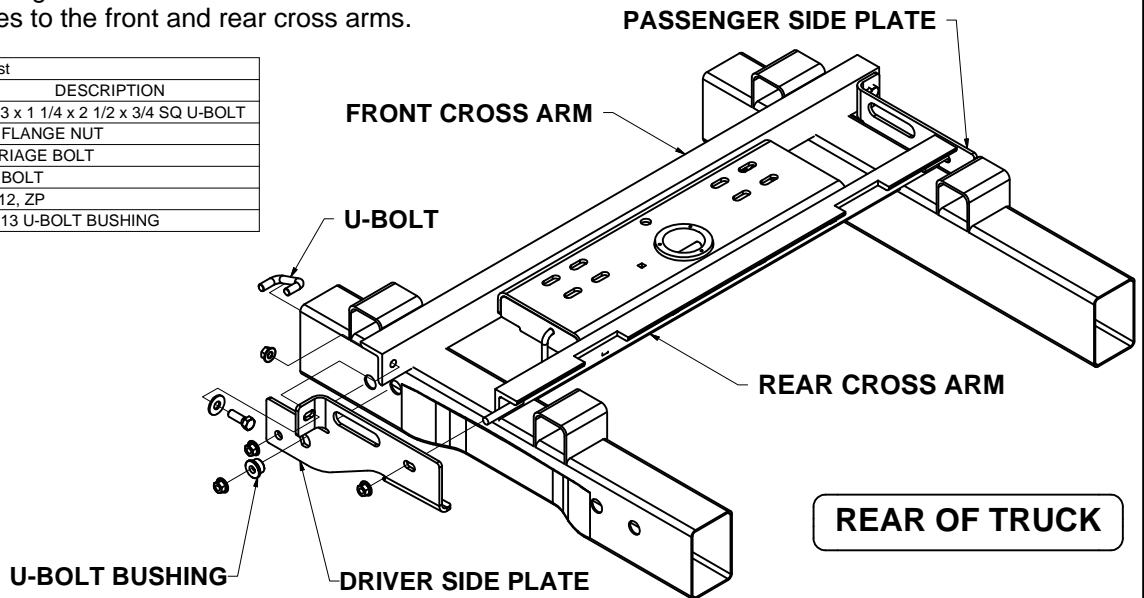

(REFER TO GOOSENECK HITCH INSTRUCTIONS FOR INSTALLATION AND OPERATING PROCEDURES)

Maintenance (Required every 30 days or prior to use)

- Keep hitch ball lubricated regularly. Use silicone spray or equivalent to prevent wear and rust.
- Keep hitch assembly free of dirt and other foreign debris.
- Check for proper torque on all nuts and bolts before each use. Also check for excessive wear.
- Check for ball wear before each use. **(Note: Do not tow trailer with worn or damaged parts)**

Curt Manufacturing Inc., warrants this product to be free of defects in material or workmanship at the time of retail purchase by the original purchaser. If the product is found to be defective, Curt Manufacturing Inc., may repair or replace the product, at their option, when the product is returned, prepaid, with proof of purchase. Alteration to, misuse of, or improper installation of this product voids the warrant. Curt Manufacturing Inc.'s liability is limited to repair or replacement of products found to be defective, and specifically excludes liability for incidental or consequential loss or damage.

DO NOT EXCEED VEHICLE MANUFACTURER'S RECOMMENDED TOWING CAPACITY.

REMOVAL OF REAR WINDOW ACCESSORIES MAY BE REQUIRED.

TRAILER

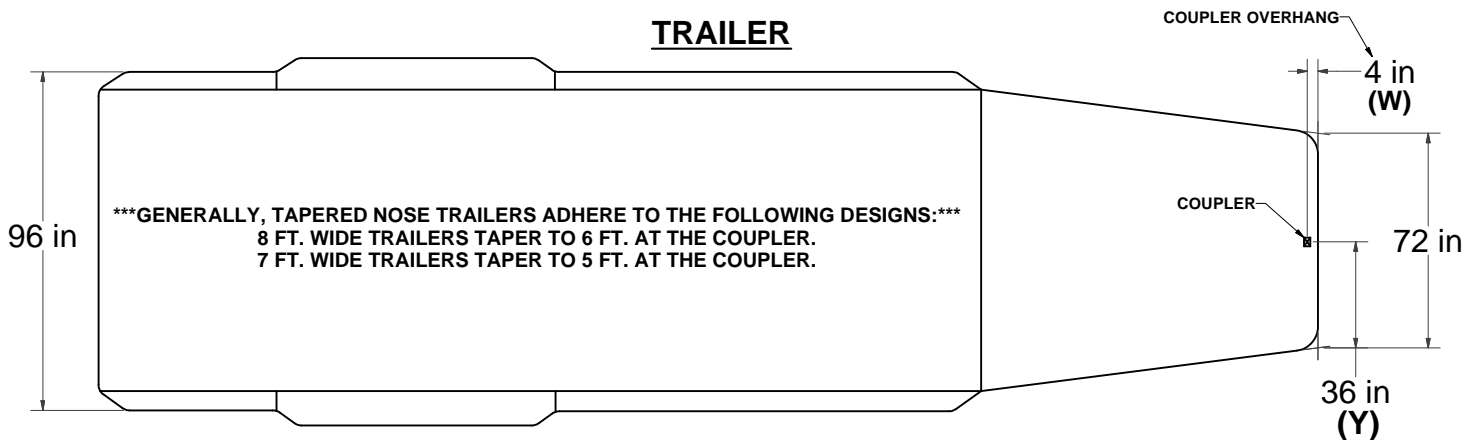

LONG & SHORT TRUCK BEDS

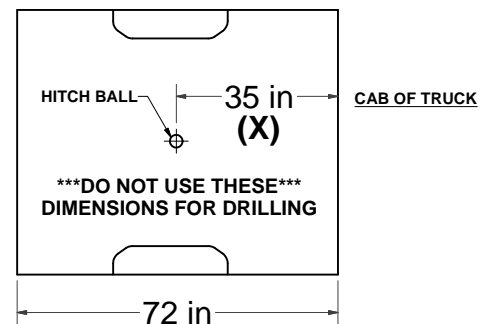
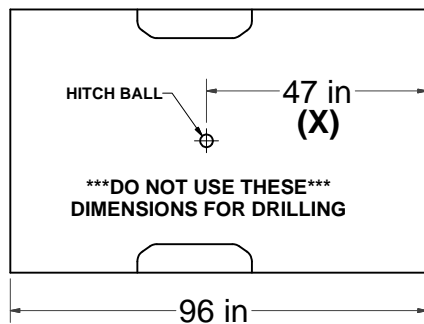

CLEARANCE CALCULATION

$$(X) - \frac{1}{2}(Y) = (Z)$$

(CAB TO BALL CENTER) - 1/2 (TRAILER WIDTH) = (MINIMUM CLEARANCE)

IF THERE IS AN OVERHANG FROM THE COUPLER THEN THE EQUATION IS:

$$[(X) - (W)] - \frac{1}{2}(Y) = (Z)$$

IF (Z) IS POSITIVE, TRAILER **WILL NOT** INTERFERE WITH CAB OF TRUCK.
 IF (Z) IS NEGATIVE, TRAILER **WILL** INTERFERE WITH CAB OF TRUCK!!!

EXAMPLE:

STANDARD TRAILER

$$X - Y = Z$$

$$35 - 36 = -1$$

(TRAILER **WILL INTERFERE** WITH CAB)

TRAILER WITH OVERHANG

$$[(X) - (W)] - Y = Z$$

$$[35 - 4] - 36 = -5$$

(TRAILER **WILL INTERFERE** WITH CAB)

YOUR CALCULATION:

(CAB TO BALL CENTER) _____

(COUPLER OVERHANG) - _____

1/2 (TRAILER WIDTH) - _____

(MINIMUM CLEARANCE) = _____

Curt Manufacturing Inc., warrants this product to be free of defects in material or workmanship at the time of retail purchase by the original purchaser. If the product is found to be defective, Curt Manufacturing Inc., may repair or replace the product, at their option, when the product is returned, prepaid, with proof of purchase. Alteration to, misuse of, or improper installation of this product voids the warrant. Curt Manufacturing Inc.'s liability is limited to repair or replacement of products found to be defective, and specifically excludes liability for incidental or consequential loss or damage.