

60636

80-96 FORD 1/2, 3/4, & 1 TON TRUCKS
 97-98 FORD 3/4 & 1 TON TRUCKS
 (WITH & WITHOUT OVERLOAD SPRINGS)
****OLD BODY STYLE** (LONG & SHORT BED)**

WARNING!! BRAKE, FUEL, AND ELECTRICAL LINES MAY NEED TO BE LOOSENED OR REPOSITIONED TO PROVIDE CLEARANCE FOR NEW HARDWARE. ALL MODELS REQUIRE MODIFICATION OR REMOVAL OF HEAT SHIELDS. ON SHORT BED MODELS, CHECK FOR ADEQUATE TURNING CLEARANCE BETWEEN THE FRONT OF ALL TRAILERS AND THE TRUCK CAB.

INSTALLATION STEPS

WARNING!! ON TWO WHEEL DRIVE TRUCKS A CLEARANCE CHECK MUST BE PERFORMED WHEN TRUCK IS LOADED AND UNLOADED TO VERIFY THE INVERTED BALL WILL NOT INTERFERE WITH THE TOP OF THE DIFFERENTIAL

BEFORE INSTALLING

An overhead lifting device, such as chain falls, engine hoist, or cable come-a-long, can be used to lift the center section of the hitch in place. Lower a loop of rope or chain through the hole in the truck bed floor and attach it to the round hitch receiver tube in the center section. Use the lifting device to raise the center section until the round hitch receiver tube that protrudes from the center section fits in the hole in the truck bed floor. Maintaining upward pressure may facilitate fastening the cross-member to the center section, especially if the truck bed floor has been distorted downward from heavy use. If you use an overhead-lifting device, it should be disconnected before squaring the center section across the frame, installing the sideplates and torquing fasteners.

- 1) Lower and remove spare tire and heat shield. The heat shield is located above the rear axle under the truck bed. It is attached with four sheet metal screws (7/32" hex head). Replace the front screw after removing the heat shield.
- 2) Mark the location for the hole in the truck bed. Measure from the tail gate end of the truck bed, by hooking a tape measure over the **back of the truck box** and marking the correct location. **(NOTE: DO NOT MEASURE FROM EDGE OF TAILGATE)** Next, mark the center between the wheel wells. This marks the center point for the drill hole. This hole location is critical for the correct installation of this hitch. Measure, mark, and saw carefully. This location will put the ball 4"-5" in front of the axle.

Short Bed Installation 48 1/16"
Long Bed Installation 48 1/16"

NOTE: If truck has a plastic bed liner, you may drill through both, but it is more difficult to accurately locate the midpoint between the wheel wells, and to keep the bed liner from moving while cutting the hole. Make a 4"(3 5/8" for C-630/C-640) hole at this location using a 4"(or 3 5/8") hole saw, or by making a 4"(or 3 5/8") circle and cutting it out with a saber saw equipped with a metal cutting blade.

- 3) **On power stroke diesels only**, loosen the tail pipe hanger bracket in front of the rear axle. Place a ratchet strap around the highest part of the tail pipe and the rear axle. Pull the tail pipe down by tightening the ratchet strap to achieve sufficient clearance for hitch parts. After installing parts, insert a 1/4" shim in the tail pipe bracket and tighten. Cut the safety chain U-bolts, on the exhaust pipe side, off to an inside length of 3 1/4", and cut 1 1/2" off of the safety chain springs.

Parts List			
ITEM	QTY	PART NUMBER	DESCRIPTION
1	6	1/2 - 13 x 1 1/2	HEX BOLT
2	6	1/2"	WASHER
3	14	HFN 1213	HEX FLANGE NUT
4	8	1/2-13 x 1 1/2	CARRIAGE BOLT
5	2	60636-TS	1/2" TUBE SPACER
6	2	1-8 x 2 1/2	HEX BOLT
7	2	1-8	HEX NUT
8	2	1 LOCK WASHER	1" HELICAL LOCK WASHER/ ZINC PLATED (HEX FREE)
9	2	1.00 DIA.	WASHER

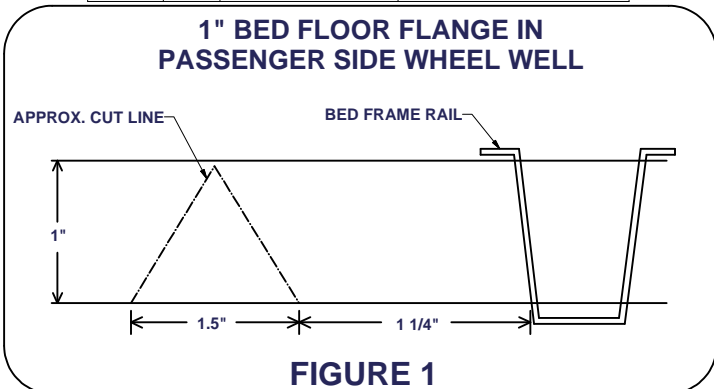
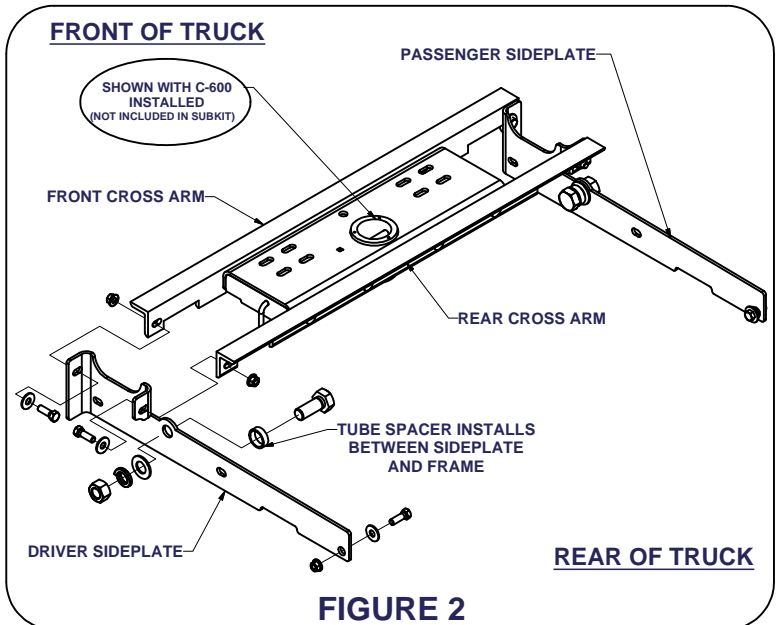

FIGURE 1

FIGURE 2

Curt Manufacturing Inc., warrants this product to be free of defects in material or workmanship at the time of retail purchase by the original purchaser. If the product is found to be defective, Curt Manufacturing Inc., may repair or replace the product, at their option, when the product is returned, prepaid, with proof of purchase. Alteration to, misuse of, or improper installation of this product voids the warrant. Curt Manufacturing Inc.'s liability is limited to repair or replacement of products found to be defective, and specifically excludes liability for incidental or consequential loss or damage.

****DO NOT EXCEED RECOMMENDED VEHICLE TOWING WEIGHT!****

60636

80-96 FORD 1/2, 3/4, & 1 TON TRUCKS
97-98 FORD 3/4 & 1 TON TRUCKS
(WITH & WITHOUT OVERLOAD SPRINGS)
****OLD BODY STYLE** (LONG & SHORT BED)**

WARNING!! BRAKE, FUEL, AND ELECTRICAL LINES MAY NEED TO BE LOOSENED OR REPOSITIONED TO PROVIDE CLEARANCE FOR NEW HARDWARE. ALL MODELS REQUIRE MODIFICATION OR REMOVAL OF HEAT SHIELDS. ON SHORT BED MODELS, CHECK FOR ADEQUATE TURNING CLEARANCE BETWEEN THE FRONT OF ALL TRAILERS AND THE TRUCK CAB.

INSTALLATION STEPS CONTINUED

- 4) Install the rear cross arm(**has the deepest notches at the ends**) by sliding it between the bed and the frame on the passenger side in an inverted V position. In order to do this, the bed floor flange must be cut about 2" to the rear of the front most bed frame rail (As shown in **Figure 1**) (**NOTE: the notches must face the front of the truck**) After it rests on the frames, slide it towards the back of the truck. Rotate the arm so the notches are perpendicular to the truck bed. This process is made easier by loosening the bed bolts in the frame rails behind the axle and using a crescent wrench or channels locks on the slotted side of the cross arm to rotate it down on its long axis, placing the side without slots flush against the truck bed floor and the cut-outs span the truck frame.
 - 5) Install the front cross arm by sliding it between the bed and the frame on the passenger side in an inverted V position. (**NOTE: the notches must face the rear of the truck.**) After it rests on the frame, slide it towards the front of the truck. Rotate the arm so the notches are perpendicular to the truck bed and the cut-outs span the truck frame.
 - 6) Before raising the center section in position between the cross arms **with the ball cylinder towards the back of truck**, drop the back exhaust hanger. The round hitch receiver that protrudes from the top of the center section must fit through the hole in the truck bed. Using (8) 1/2" carriage bolts, attach the center section to the holes in both cross arms. **Finger tight only** with (8) 1/2" flange nuts. When re-attaching exhaust hanger, bend upward to adjust if tailpipes touch the center section.
 - 7) Square the center section and cross arms across the frame. Place a 1 1/2" bolt with a washer through the back flange of the sideplate into the rear cross arm and **Finger tight only** with a 1/2" flange nut. (As shown in **Figure 2**) Place a 1 1/2" bolt with a flat washer through the front flange of the sideplate into the front cross arm. (As shown in **Figure 2**) **Finger tight only** with a 1/2" flange nut. (**REPEAT FOR OTHER SIDE**) (**NOTE: locate and release the brake line and fuel line retaining clip from the frame rail on the driver side before attaching driver sideplate.**) If bed bolts were loosened in step 4, re-tighten them now.
 - 8) **Trucks without overload springs:** Align the large 1" hole and the rear hole on each sideplate to the existing holes in the truck frame. Place a 1" bolt with a 1" washer through the inside of the frame. Place the tube spacer between the frame and sideplate and attach a 1" washer, 1" lock washer, and 1" nut on the outside of the sideplates and **Finger tight only**. (As shown in **Figure 2**) On the rear of the sideplate, place a 1/2" x 1 1/2" bolt through the inside of the truck frame through the sideplate and attach with a 1/2" flange nut. (As shown in **Figure 2**) **Finger tight only**.
- Trucks with overload springs:** The sideplates can be modified to fit trucks with overload springs. To do this, cut 10" off the back of the sideplates(the narrow end of the sideplates). Install the 1" bolts as described in the above paragraph. Now **drill a 1/2" hole** through the frame rails at the slot nearest the front of the sideplate. Attach with a 1/2" x 1 1/2" bolt and washer from the inside of the frame and **Finger tight only** with a 1/2" flange nut.
- 9) With the sideplates installed on both sides, torque all 1" fasteners to 300 ft-lbs. and all 1/2" fasteners to 110 ft-lbs in the following order:
First: Torque the center section to the front and rear cross arms.
Second: Torque the sideplate flanges to the front and rear cross arms.
Third: Torque the sideplates to the truck frame on both sides.
 - 10) When installing the C-600 handle, it may be necessary to notch the bed floor flange on the driver side of the truck similarly to the notch placed on the passenger side in step 4. The placement of the notch will be determined by the handle placement.

(REFER TO GOOSENECK HITCH INSTRUCTIONS FOR INSTALLATION AND OPERATING PROCEDURES)

Maintenance (Required every 30 days or prior to use)

1. Keep hitch ball lubricated regularly. Use silicone spray or equivalent to prevent wear and rust.
2. Keep hitch assembly free of dirt and other foreign debris.
3. Check for proper torque on all nuts and bolts before each use. Also check for excessive wear.
4. Check for ball wear before each use. (**Note: Do not tow trailer with worn or damaged parts.**)

Curt Manufacturing Inc., warrants this product to be free of defects in material or workmanship at the time of retail purchase by the original purchaser. If the product is found to be defective, Curt Manufacturing Inc., may repair or replace the product, at their option, when the product is returned, prepaid, with proof of purchase. Alteration to, misuse of, or improper installation of this product voids the warrant. Curt Manufacturing Inc.'s liability is limited to repair or replacement of products found to be defective, and specifically excludes liability for incidental or consequential loss or damage.

DO NOT EXCEED VEHICLE MANUFACTURER'S RECOMMENDED TOWING CAPACITY.

CAB TO TRAILER CLEARANCE

REMOVAL OF REAR WINDOW ACCESSORIES MAY BE REQUIRED.

TRAILER

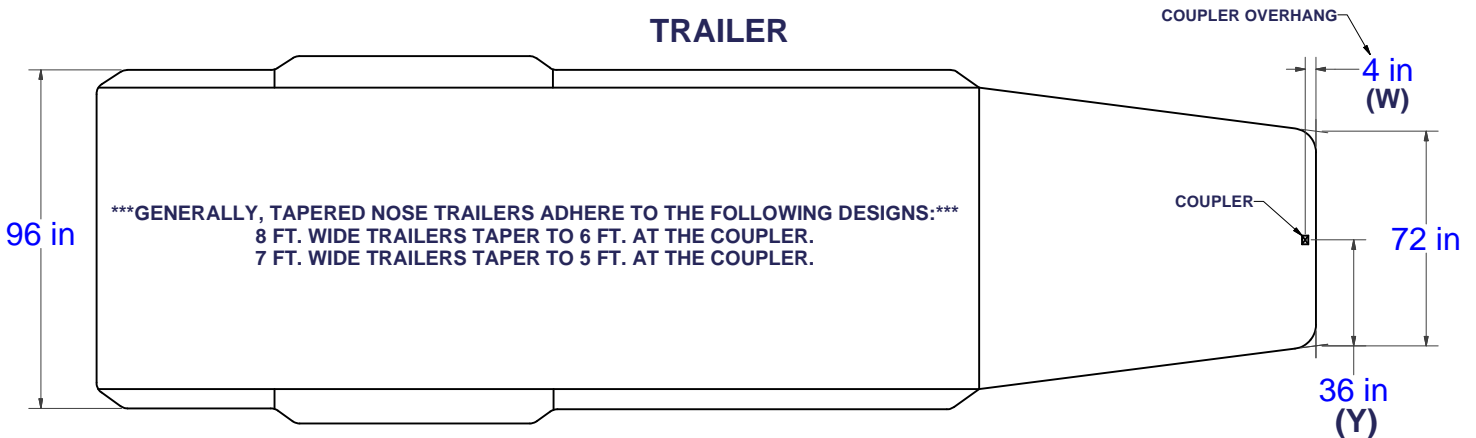

LONG & SHORT TRUCK BEDS

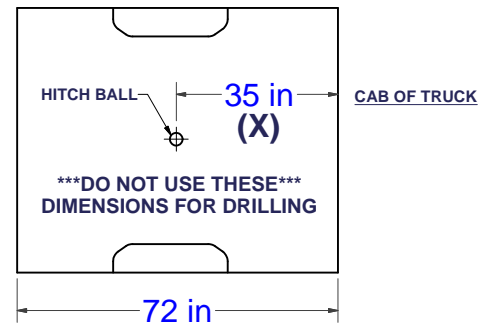
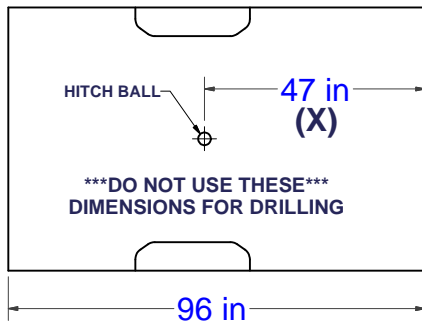

$$\begin{matrix} \text{(CAB TO BALL CENTER)} & - & 1/2 \text{ (TRAILER WIDTH)} & = & \text{(MINIMUM CLEARANCE)} \\ \text{(X)} & - & \text{(Y)} & = & \text{(Z)} \end{matrix}$$

IF THERE IS AN OVERHANG FROM THE COUPLER THEN THE EQUATION IS:

$$[(X) - (W)] - (Y) = (Z)$$

IF (Z) IS POSITIVE, TRAILER **WILL NOT** INTERFERE WITH CAB OF TRUCK.
 IF (Z) IS NEGATIVE, TRAILER **WILL** INTERFERE WITH CAB OF TRUCK!!!

EXAMPLE:

STANDARD TRAILER

$$X - Y = Z$$

$$35 - 36 = -1$$

(TRAILER **WILL INTERFERE** WITH CAB)

TRAILER WITH OVERHANG

$$[(X) - (W)] - Y = Z$$

$$[35 - 4] - 36 = -5$$

(TRAILER **WILL INTERFERE** WITH CAB)

YOUR CALCULATION:

(CAB TO BALL CENTER) _____

(COUPLER OVERHANG) - _____

1/2 (TRAILER WIDTH) - _____

(MINIMUM CLEARANCE) = _____

Curt Manufacturing Inc., warrants this product to be free of defects in material and/or workmanship at the time of retail purchase by the original purchaser. If the product is found to be defective, Curt Manufacturing Inc., may repair or replace the product, at their option, when the product is returned, prepaid, with proof of purchase. Alteration to, misuse of, or improper installation of this product voids the warranty. Curt Manufacturing Inc.'s liability is limited to repair or replacement of products found to be defective, and specifically excludes liability for incidental or consequential loss or damage.