

# INSTALLATION MANUAL

# 70134

## Level of Difficulty

Moderate

Installation difficulty levels are based on time and effort involved and may vary depending on the installer level of expertise, condition of the vehicle and proper tools and equipment.

## Installed Attachment Tabs

Height	21"
Width	37-1/2"

## Parts List

Item	Qty	Description
1	1	Tow bar base plate, driver
2	1	Tow bar base plate, passenger
3	2	Tow bar mounting tab
4	2	Spacer, T-shaped
5	2	Safety cable, 7,500 lbs.
6	4	Hex head cap screw, M10 x 1.25" x 50mm
7	2	Hex head cap screw, M10 x 1.5" x 70mm
8	2	Conical-toothed lock washer, 7/16"
9	4	Lock washer, 7/16"
10	4	Flat washer, 7/16"
11	2	Caplugs
12	2	Quick link, 1/2"
13	2	Rivet, M6

## Tools Required

Torque wrench	Drill
Socket, 8mm	Drill bit, 3/16"
Socket, 10mm	Reciprocating saw
Socket, 15mm	Tape Measure
Socket, 16mm	Utility knife
Socket, 17mm	Flat screwdriver
Wrench, 30mm	--

## ⚠ WARNING

Never exceed the vehicle manufacturer's recommended gross vehicle weight rating (GVWR).

## Product Photo

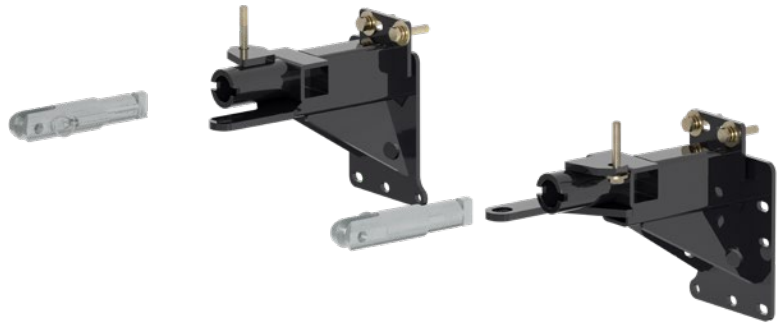

## ⚠ CAUTION

Take care when cutting any plastic or metal as injury may occur if done improperly.

## NOTICE

Before you begin installation, read all instructions thoroughly.

Proper tools will improve the quality of installation and reduce the time required.

This installation requires:

- Remove factory tow loops
- Fishwiring to install hardware

To help prevent damage to the product or vehicle, refer to the specified torque specifications when securing hardware during the installation process.

If equipped, we recommend removing the base plate attachment tabs when not in use.

## SAFETY INSTRUCTIONS

Safety glasses should be worn at all times while installing this product.

# ASSEMBLY

## Parts List

Item	Qty	Description
1	1	Tow bar base plate, driver
2	1	Tow bar base plate, passenger
3	2	Tow bar mounting tab
4	2	Spacer, T-shaped
5	2	Safety cable, 7,500 lbs.
6	4	Hex head cap screw, M10 x 1.25" x 50mm
7	2	Hex head cap screw, M10 x 1.5" x 70mm
8	2	Conical-toothed lock washer, 7/16"
9	4	Lock washer, 7/16"
10	4	Flat washer, 7/16"
11	2	Caplugs
12	2	Quick link, 1/2"
13	2	Rivet, M6

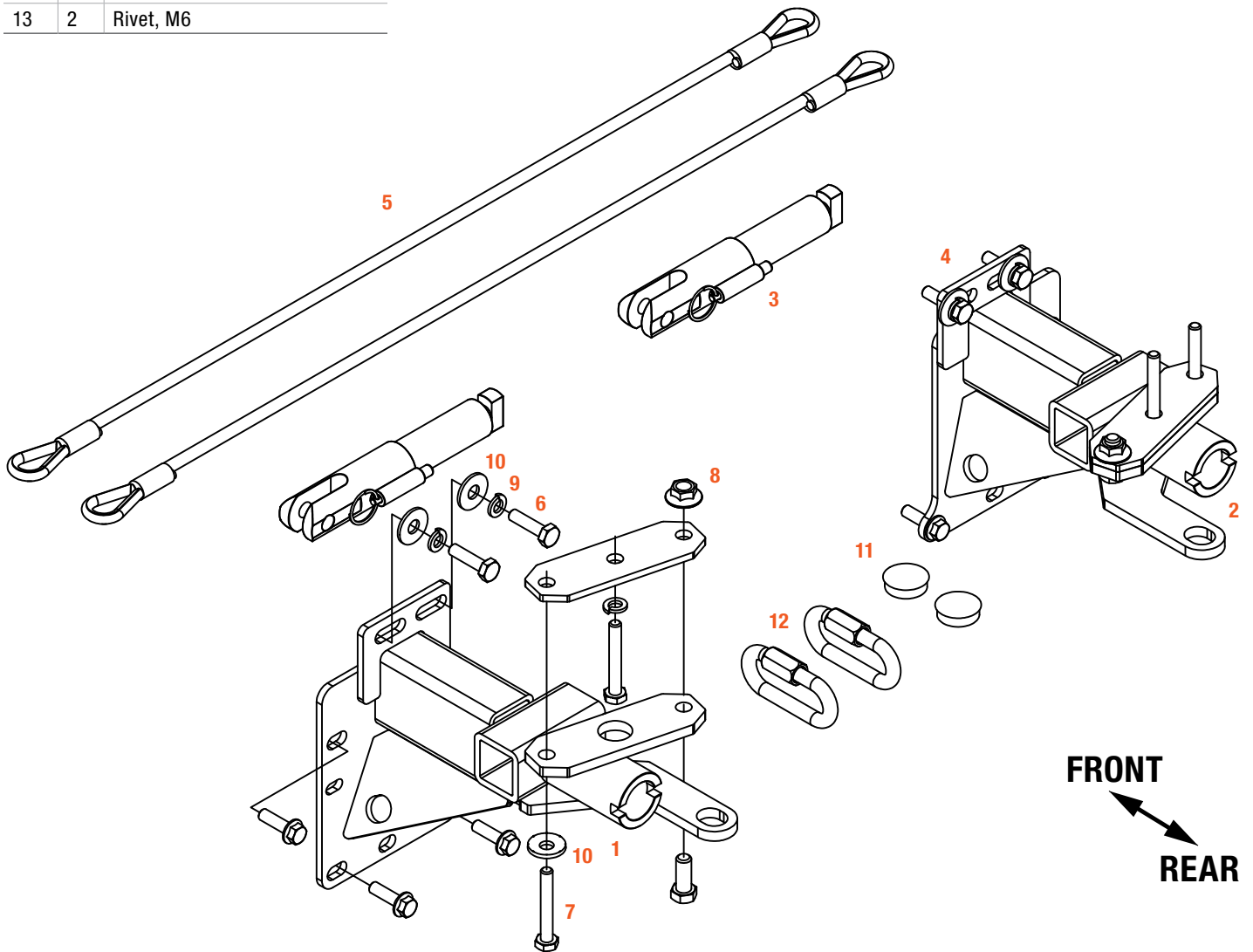

### Step 1

Remove the twelve push fasteners from the top of the radiator cover and set aside.



### Step 2

Remove three screws from the backside of the bumper cover near the fender and headlight using a 10mm socket. There will be two screws in the corner and one below the mounting bracket.

Repeat on the other side of the vehicle.



### Step 3

Remove three screws securing the bumper fascia to the wheel well liner using an 8mm socket. Pull back the wheel well liner and remove the screw behind the trim using a 10mm socket.

Repeat on the other side of the vehicle.



### Step 4

Remove two rivets from the lower corners of the bumper cover, one on each side, with a 3/16" drill bit and drill.

Remove the four screws from the lower center of the bumper cover using a 10mm socket. There will be two on each side.



### Step 5

Raise the corners of the bumper cover upwards and outward to release. Carefully continue unclipping the bumper cover from the vehicle toward the center under the headlights. Unclip the fog light harness on the driver side and unhook from the frame before carefully setting the bumper cover aside for later.

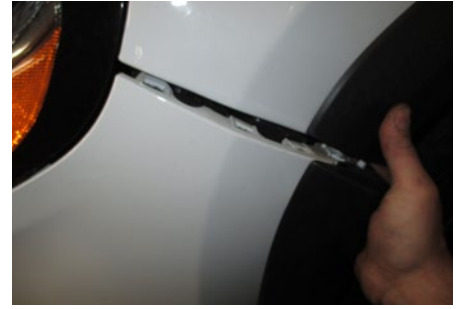

### Step 6

Remove the two bolts from underneath the tow hook using a 16mm socket. Use a 30mm socket to remove the flange nut from behind the tow hook, remove from the vehicle and return the tow hook to the vehicle owner.

Repeat on the other side of the vehicle.



### Step 7

Remove the three bolts securing the frame beam extension to the vehicle and two bolts from the bottom tab of the steel bumper using a 15mm socket. Use a 10mm socket to remove the nut from the fascia extension on both sides of the vehicle. Return the beam extensions to the vehicle owner.

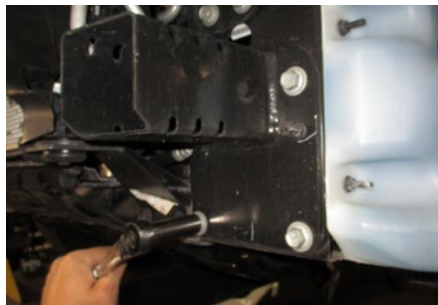

### Step 8

Raise the base plate onto the vehicle. Slip the T-shaped spacer (#4) between the upper tab of the base plate and the lower bumper flange. Reinstall the three frame beam extension bolts.

**Note:** If present, remove the weldnut on the passenger side only for baseplate to set flat.



### Step 9

Install M10 x 1.25" x 50mm bolts (#6) with 7/16" flat washers (#10) and 7/16" lock washers (#9) into the lower bumper bolt holes.

Repeat on the other side of the vehicle.

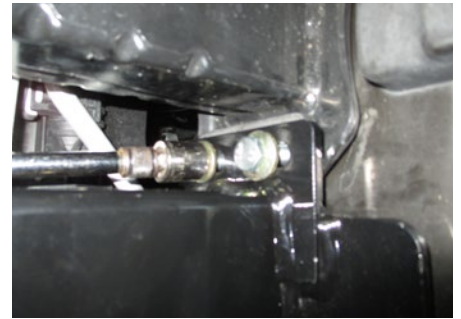
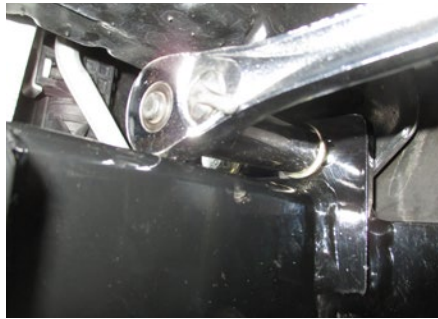

### Step 10

Install the M10 x 1.25" x 50mm bolt (#7) and 7/16" lock washer (#9) into the weldnut that secured the red recovery loop. Torque all M10 fasteners to 48 lb-ft.

Repeat on the other side of the vehicle.

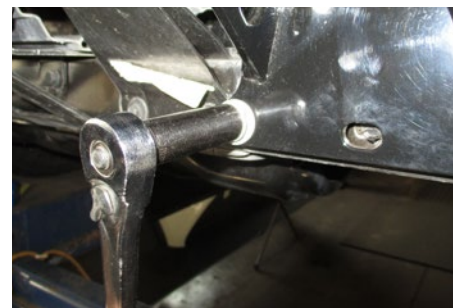

### Step 11

Install the permanent safety cables (#5), looping them around the vehicle frame and linking them to the tow bar base plate (#1, #2). There must be one cable on each side of the vehicle. Make sure the cables do not pinch or interfere with any hoses, wiring or other components (see Installing the Permanent Base Plate Safety Cables for additional information).



### Step 12

Trim the bumper cover openings as needed for baseplate clearance.



### Step 13

Reinstall the bumper and radiator covers, making sure to reconnect wiring as well.



### Step 14

Install new supplied plastic rivets (#13) where they were removed in step 4. Enlarge hole slightly if needed.



## Final Installed Image



# SAFETY CABLE INSTALLATION

## Installing the Permanent Base Plate Safety Cables

When dinghy towing a vehicle with a tow bar, base plate safety cables should be used at all times. In the event of a disconnect, the safety cables are designed to help prevent complete vehicle separation. When installing the safety cables, use the illustrations below as a guide.

### Installation guidelines

1. The cables must be connected to the base plate and the vehicle frame.
2. Two cables must be installed.
3. Each cable must meet or exceed the gross weight of the towed vehicle.
4. Make sure cables do not pinch or interfere with hoses, wiring or other components.

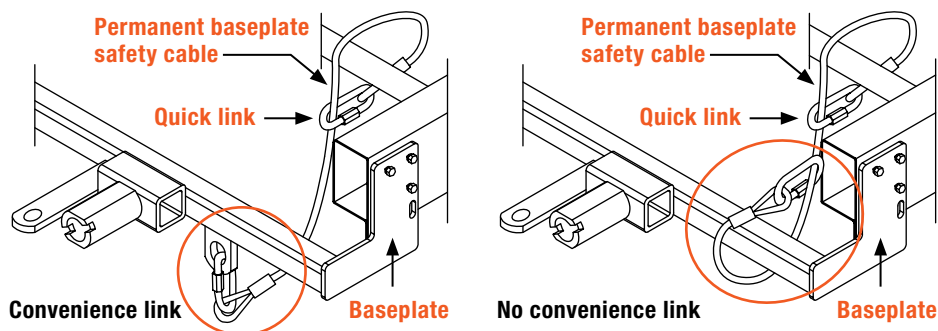

**Note:** Base plate safety cables are not a replacement for safety chains connecting the tow vehicle to the towed vehicle.

# ADDITIONAL INFORMATION

## Towing Tips

### Check your equipment

Periodically check the condition of all towing equipment. Ensure all fasteners are tight and that all structural components are sound. Do not tow with worn or damaged parts.

### Towing vehicle and trailer manufacturer's recommendations

Review the owner's manual for your towing vehicle and trailer for specific recommendations, capacities and requirements.