

**11302****NISSAN JUKE (FWD MODEL)**

1/16/2013

GROSS LOAD CAPACITY WHEN USED AS A WEIGHT CARRYING HITCH: 2,000 LBS. TRAILER WEIGHT &amp; 200 LBS. TONGUE WEIGHT.

**\*\*\*DO NOT EXCEED VEHICLE MANUFACTURER'S RECOMMENDED TOWING CAPACITY.\*\*\*****WARNING: ALL NON-TRAILER LOADS APPLIED TO THIS PRODUCT MUST BE SUPPORTED BY AUXILIARY STABILIZING STRAPS.****\*\* FAILURE TO PROPERLY SUPPORT NON-TRAILER LOADS WILL VOID PRODUCT WARRANTY\*\***

Parts List			
ITEM	QTY	PART NUMBER	DESCRIPTION
1	2	1/2"	WASHER
2	2	1/2-13 x 1 3/4	CARRIAGE BOLT
3	2	1/2"	FISHWIRE TOOL
4	3	HFN 1213	HEX FLANGE NUT
5	2	CM-SP6	.250 x 1.00 x 3.00" SQUARE HOLE SPACER
6	1	CM-SP12	.250 x 1.00 x 2.00" SQUARE HOLE SPACER
7	1	1/2 - 13 x 2"	CARRIAGE BOLT

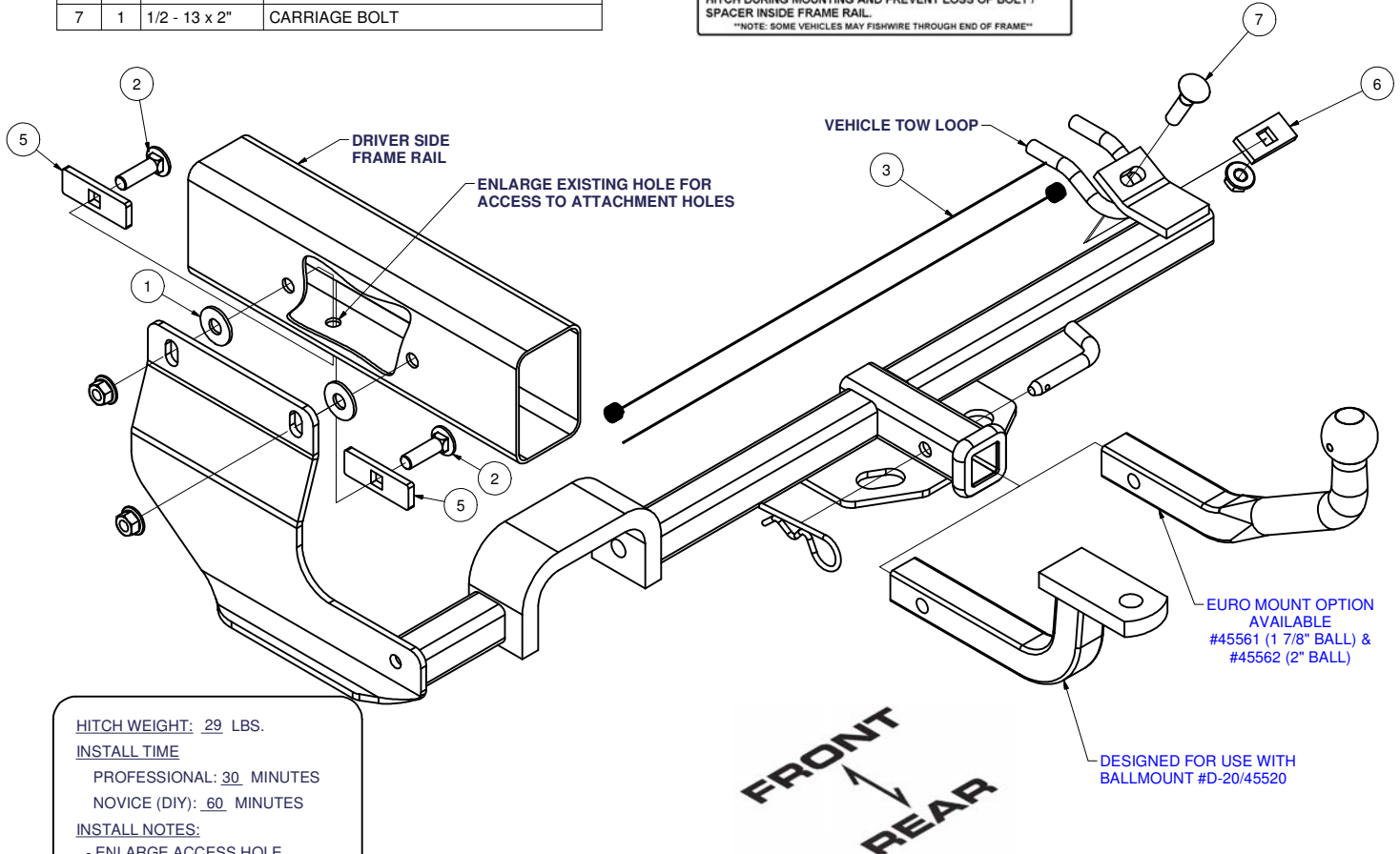
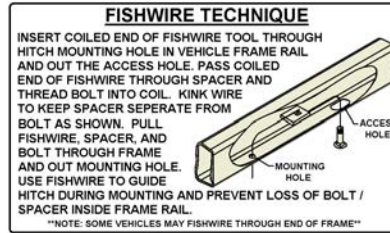
HITCH WEIGHT: 29 LBS.**INSTALL TIME**PROFESSIONAL: 30 MINUTESNOVICE (DIY): 60 MINUTES**INSTALL NOTES:**

- ENLARGE ACCESS HOLE
- FISHWIRING REQUIRED

**INSTALLATION STEPS**

- 1) Lower vehicle exhaust by removing rubber isolator from muffler.
- 2) Enlarge existing hole under frame rail to 1" as shown above.
- 3) Fishwire 1 3/4" carriage bolts with CM-SP6 spacers through access hole and out mounting holes and install 1/2" washers. Raise hitch into position with U-shaped bar above tailpipe, remove fishwires, and secure hitch with 1/2" flange nuts.
- 4) Place remaining 2" carriage bolt through hitch onto tow loop and place small CM-SP12 spacer on bottom of tow loop. Raise passenger side and secure with flange nut.  
Note: If exhaust hanger rod interferes with side bracket, it may be necessary to bend hanger rod slightly inboard. Torque all 1/2" fasteners to 110 ft.-lbs.
- 5) Raise exhaust back into position.

**PERIODICALLY CHECK THIS RECEIVER HITCH TO ENSURE THAT ALL FASTENERS ARE TIGHT AND THAT ALL STRUCTURAL COMPONENTS ARE SOUND.**



The **FIRST** Name  
in Towing Products™

Trailer Hitches

YEARS: 2011

MAKE: NISSAN

MODEL: JUKE (FWD)

STYLE: CROSSOVER

**WARNING: NEVER EXCEED YOUR VEHICLE MANUFACTURER'S RECOMMENDED TOWING CAPACITY**

**WEIGHT CARRYING:**  
 TRAILER WEIGHT: 2000 LBS.  
 TONGUE WEIGHT: 200 LBS.

**INSTALLATION TIME: 30 MIN.**

THE INSTALL TIME LISTED IS FOR PROFESSIONAL INSTALLERS. IF YOU ARE HESITANT TO UNDERTAKE THIS TASK ON YOUR OWN, CONTACT AN AUTHORIZED CURT INSTALLER FOR ADDITIONAL ASSISTANCE.



**INSTALLATION REQUIRES:**

 <b>DIE GRINDER</b>	 <b>RATCHET</b>	 <b>TORQUE WRENCH</b>
 <b>3/4" SOCKET</b>	 <b>PRY BAR</b>	 <b>SAFETY GLASSES</b>

**INSTALLATION TIPS:**

- BEFORE YOU BEGIN INSTALLATION, READ ALL INSTRUCTIONS THOROUGHLY.
- TO EASE INSTALLATION, 2 PEOPLE MAY BE REQUIRED.
- USING PROPER TOOLS WILL GREATLY IMPROVE THE QUALITY OF THE INSTALL AND REDUCE THE TIME REQUIRED.

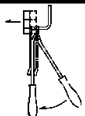
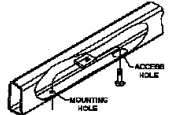
**LEVEL OF DIFFICULTY: MODERATE**

EASY	MODERATE	CHALLENGING
	Lower Exhaust	
	Fishwiring required	
	Enlarge Existing Hole	

**VEHICLE PHOTO:**



REPRESENTATIVE PHOTO

**HITCH ILLUSTRATION:**

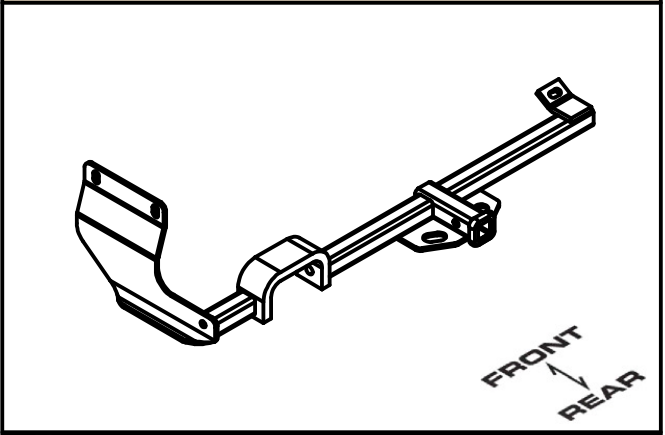

MAKE SURE YOUR HITCH MATCHES

**PERIODICALLY CHECK THIS RECEIVER HITCH TO ENSURE ALL FASTENERS ARE TIGHT AND ALL STRUCTURAL COMPONENTS ARE SOUND**  
 CURT Manufacturing LLC. warrants this product to be free of defects in material and/or workmanship at the time of retail purchase by the original purchaser. If the product is found to be defective, Curt Manufacturing LLC. may repair or replace the product at their option, when the product is returned, prepaid, with proof of purchase. Alteration to, misuse of, or improper installation of this product voids the warranty. Curt Manufacturing LLC.'s liability is limited to repair or replacement of products found to be defective, and specifically excludes liability for incidental or consequential loss or damage.

## INSTALLATION WALKTHROUGH:

Parts List			
ITEM	QTY	PART NUMBER	DESCRIPTION
1	2	1/2"	WASHER
2	2	1/2-13 x 1 3/4	CARRIAGE BOLT
3	2	1/2"	FISHWIRE TOOL
4	3	HFN 1213	HEX FLANGE NUT
5	2	CM-SP6	.250 x 1.00 x 3.00" SPACER
6	1	CM-SP12	.250 x 1.00 x 2.00" SPACER
7	1	1/2 - 13 x 2"	CARRIAGE BOLT

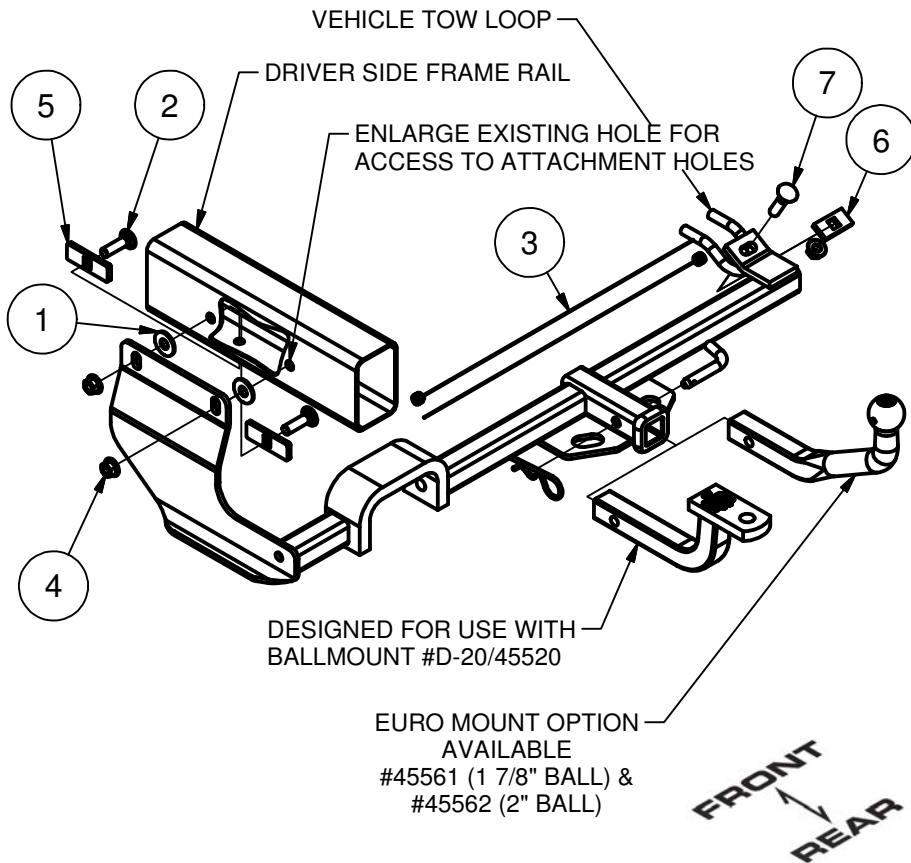

1. Lower vehicle exhaust by removing rubber isolator from muffler.



2. Enlarge existing hole under frame rail to 1" as shown.

Enlarge hole for access to attachment holes



## INSTALLATION WALKTHROUGH:

3. Fishwire 1 3/4" carriage bolts with CM-SP6 spacers through access hole and out mounting holes and install 1/2" washers. Raise hitch into position with U-shaped bar above tailpipe. Remove fishwires and secure hitch with 1/2" flange nuts.



4. Place remaining 2" carriage bolt through hitch onto tow loop and place small CM-SP12 spacer on bottom of tow loop. Raise passenger side and secure with flange nut. Torque all 1/2" fasteners to 110 ft.-lbs.



5. Raise exhaust back into position if removed prior to installation. **Note:** If exhaust hanger rod interferes with side bracket, it may be necessary to bend hanger rod slightly inboard.



Installation is complete.

