



12083 INSTALLATION INSTRUCTIONS



Safety glasses should be worn at all times while installing this product.

YEARS: 2013

MAKE: ACURA

MODEL: RDX

STYLE: CROSSOVER

WARNING: NEVER EXCEED YOUR VEHICLE MANUFACTURER'S RECOMMENDED TOWING CAPACITY

WEIGHT CARRYING:
TRAILER WEIGHT: 3,500 LBS.
TONGUE WEIGHT: 350 LBS.

INSTALLATION TIME: 20 MIN.

THE INSTALL TIME LISTED IS FOR PROFESSIONAL INSTALLERS. IF YOU ARE HESITANT TO UNDERTAKE THIS TASK ON YOUR OWN, CONTACT AN AUTHORIZED CURT INSTALLER FOR ADDITIONAL ASSISTANCE.

INSTALLATION REQUIRES:

 SAFETY GLASSES	 SPRAY LUBRICANT	 WIRE PIPE BRUSH
 RATCHET	 3/4" 19 mm SOCKET	 6" SOCKET EXTENSION
 TORQUE WRENCH		

INSTALLATION TIPS:

- BEFORE YOU BEGIN INSTALLATION, READ ALL INSTRUCTIONS THOROUGHLY.
- TO EASE INSTALLATION, 2 PEOPLE MAY BE REQUIRED.
- USING PROPER TOOLS WILL GREATLY IMPROVE THE QUALITY OF THE INSTALL AND REDUCE THE TIME REQUIRED.

LEVEL OF DIFFICULTY: EASY

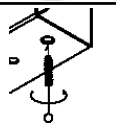
EASY	MODERATE	CHALLENGING
	- NO DRILLING REQUIRED	
	- USE EXISTING WELDNUTS	

VEHICLE PHOTO:



REPRESENTATIVE PHOTO

TRAILER HITCH ILLUSTRATION:

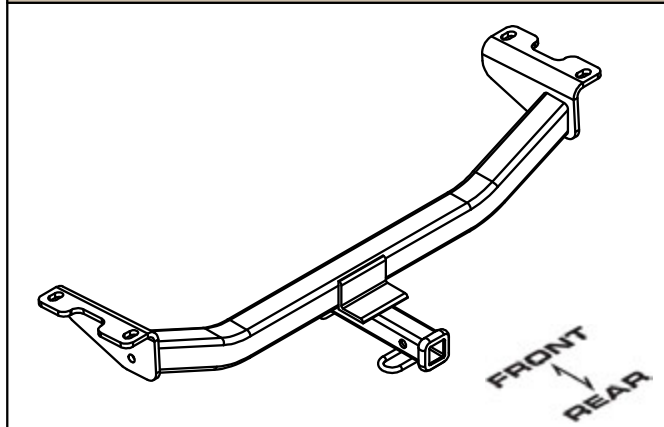

MAKE SURE YOUR HITCH MATCHES

PERIODICALLY CHECK THIS RECEIVER HITCH TO ENSURE ALL FASTENERS ARE TIGHT AND ALL STRUCTURAL COMPONENTS ARE SOUND

CURT Manufacturing LLC. warrants this product to be free of defects in material and/or workmanship at the time of retail purchase by the original purchaser. If the product is found to be defective, Curt Manufacturing LLC. may repair or replace the product at their option, when the product is returned, prepaid, with proof of purchase. Alteration to, misuse of, or improper installation of this product voids the warranty. Curt Manufacturing LLC.'s liability is limited to repair or replacement of products found to be defective, and specifically excludes liability for incidental or consequential loss or damage.

INSTALLATION WALKTHROUGH:

Parts List			
ITEM	QTY	PART NUMBER	DESCRIPTION
1	2	1/2-13	HANDLE NUT
2	2	M12 - 1.25 x 40 HEX	HEX BOLT
3	4	1/2"	CONICAL TOOTHED WASHER
4	2	1/2 - 13 x 1 1/2	HEX BOLT

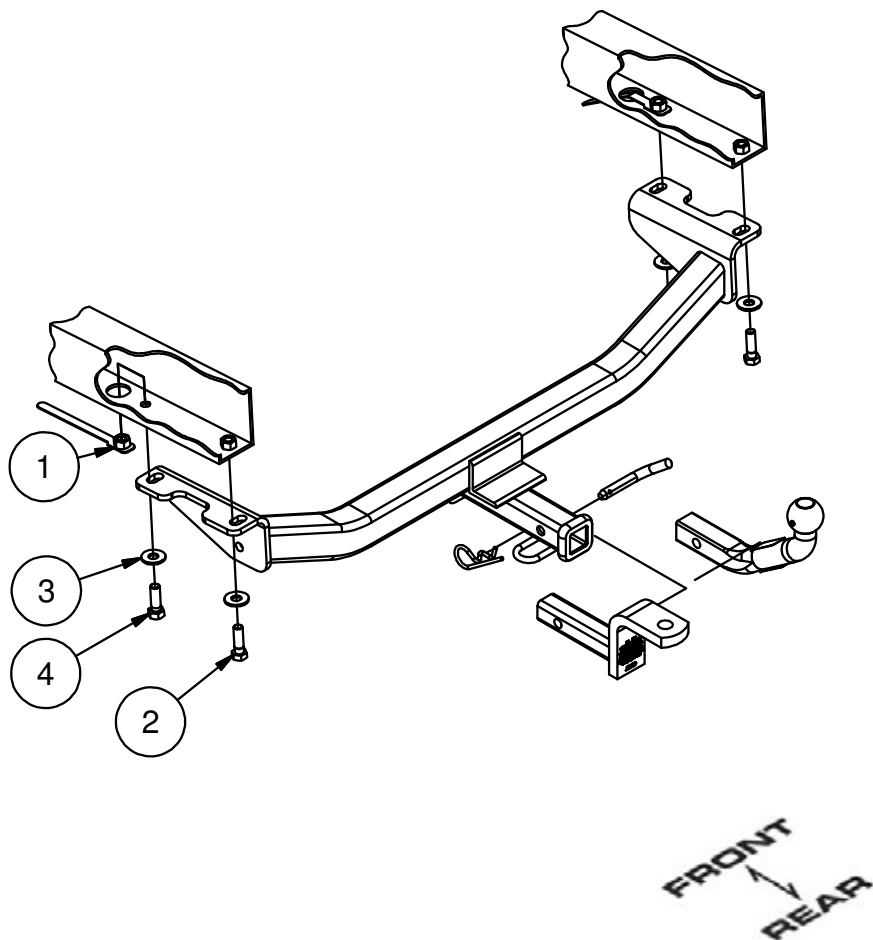

1. Locate (2) existing weldnuts in rear of vehicle frame. Spray lubricant or compressed air into hole. For heavy debris, use a small wire brush. (Be careful not to damage threads.)

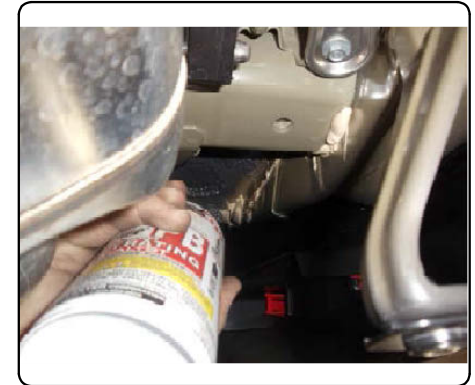

- ↓
2. Raise hitch into position so the slots in the hitch are aligned with the two existing weldnuts in the vehicle frame. Loosely secure with M12 bolts and 1/2" conical toothed washers.

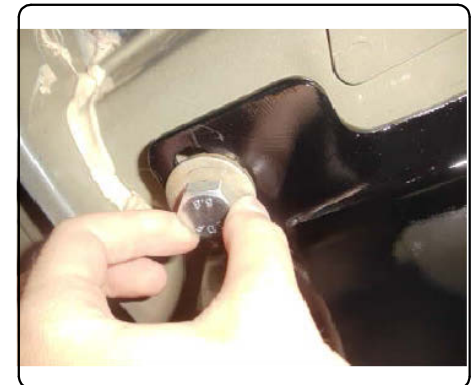
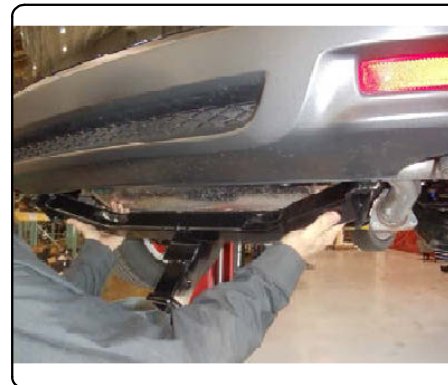

INSTALLATION WALKTHROUGH:

3. Bend the 1/2-13 handle nut tab and insert it into the access hole in the vehicle frame. Center the handle nut over the open bolt hole in the frame.



4. Use 1/2-13 hex bolts and 1/2" conical toothed washers and insert hardware through hitch plate and vehicle frame into the handle nut and tighten.

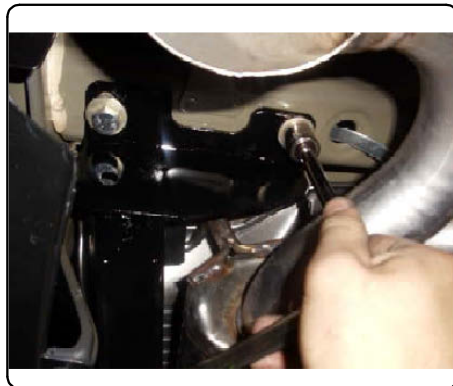
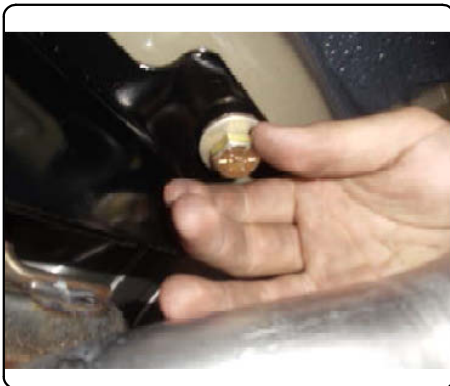

5. Torque all 1/2" hardware to 110 ft-lbs and all M12 hardware to 86 ft-lbs.



6. Installation is complete.



12083

ACURA RDX

GROSS LOAD CAPACITY WHEN USED AS A WEIGHT CARRYING HITCH: 3,500 LBS. TRAILER WEIGHT & 350 LBS. TONGUE WEIGHT.

DO NOT EXCEED VEHICLE MANUFACTURER'S RECOMMENDED TOWING CAPACITY.

WARNING: ALL NON-TRAILER LOADS APPLIED TO THIS PRODUCT MUST BE SUPPORTED BY 18050 STABILIZING STRAPS.

** FAILURE TO PROPERLY SUPPORT NON-TRAILER LOADS WILL VOID PRODUCT WARRANTY**

Parts List			
ITEM	QTY	PART NUMBER	DESCRIPTION
1	2	M12 - 1.25 x 40 HEX	HEX BOLT
2	2	1/2 - 13 x 1 1/2	HEX BOLT
3	4	1/2"	CONICAL TOOTHED WASHER
4	2	1/2-13	HANDLE NUT

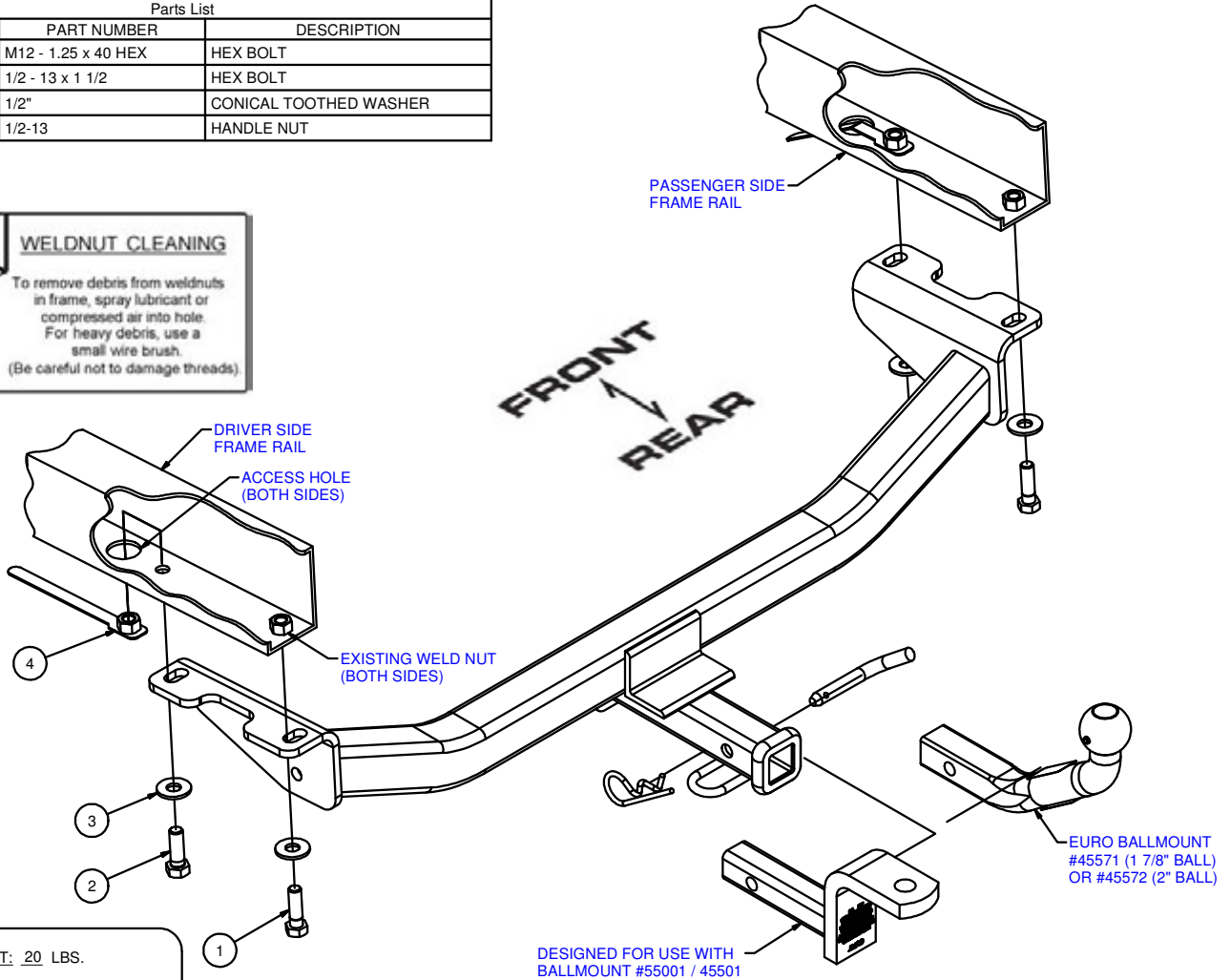
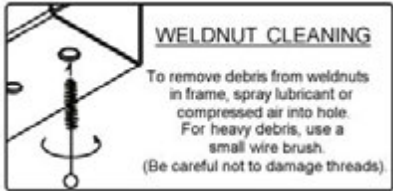

HITCH WEIGHT: 20 LBS.
 INSTALL TIME
 PROFESSIONAL: 20 MINUTES
 NOVICE (DIY): 45 MINUTES
 INSTALL NOTES:
 -NO DRILLING REQUIRED

- INSTALLATION STEPS:**
1. Raise hitch into position so the slots in the hitch are aligned with the two existing weldnuts in the vehicle frame. Loosely secure with M12 bolts and 1/2" conical toothed washers.
 2. Bend the 1/2-13 handle nut tab and insert it into the access hole in the vehicle frame. Center the handle nut over the open bolt hole in frame. Use 1/2-13 hex bolts and 1/2" conical toothed washers and insert hardware through hitch plate and vehicle frame into the handle nut and tighten.
 3. Torque all 1/2" hardware to 110 ft-lbs and all M12 hardware to 86 ft-lbs.
- PERIODICALLY CHECK THIS RECEIVER HITCH TO ENSURE THAT ALL FASTENERS ARE TIGHT AND THAT ALL STRUCTURAL COMPONENTS ARE SOUND.**

Curt Manufacturing Inc., warrants this product to be free of defects in material and/or workmanship at the time of retail purchase by the original purchaser. If the product is found to be defective, Curt Manufacturing Inc., may repair or replace the product, at their option, when the product is returned, prepaid, with proof of purchase. Alteration to, misuse of, or improper installation of this product voids the warranty. Curt Manufacturing Inc.'s liability is limited to repair or replacement of products found to be defective, and specifically excludes liability for incidental or consequential loss or damage.