

12126

KIA SPORTAGE / HYUNDAI TUCSON

GROSS LOAD CAPACITY WHEN USED AS A WEIGHT CARRYING HITCH: 3500 LBS. TRAILER WEIGHT & 300 LBS. TONGUE WEIGHT.
*****DO NOT EXCEED VEHICLE MANUFACTURER'S RECOMMENDED TOWING CAPACITY.*****

Parts List			
ITEM	QTY	PART NUMBER	DESCRIPTION
1	6	M10-1.25 x 35	HEX TAP BOLT
2	6	3/8"	CONICAL TOOTHED WASHER

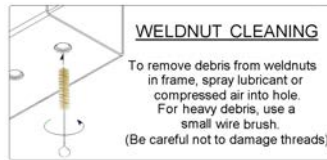

RUBBER ISOLATOR REMOVAL DIAGRAM

This technique can be used if an Exhaust Hanger Removal Pliers is not available.

Using a 5/8" open end wrench, slide the wrench up to the rubber isolator, cradling the hanger rod as shown. Next place the flat edge of a pry bar between the wrench and the hanger stop or hanger rod. Then simply rotate the pry bar toward the wrench to remove the rubber isolator.

Note: Using a spray lubricant or soapy water on the hanger rod and the rubber isolator helps removal.

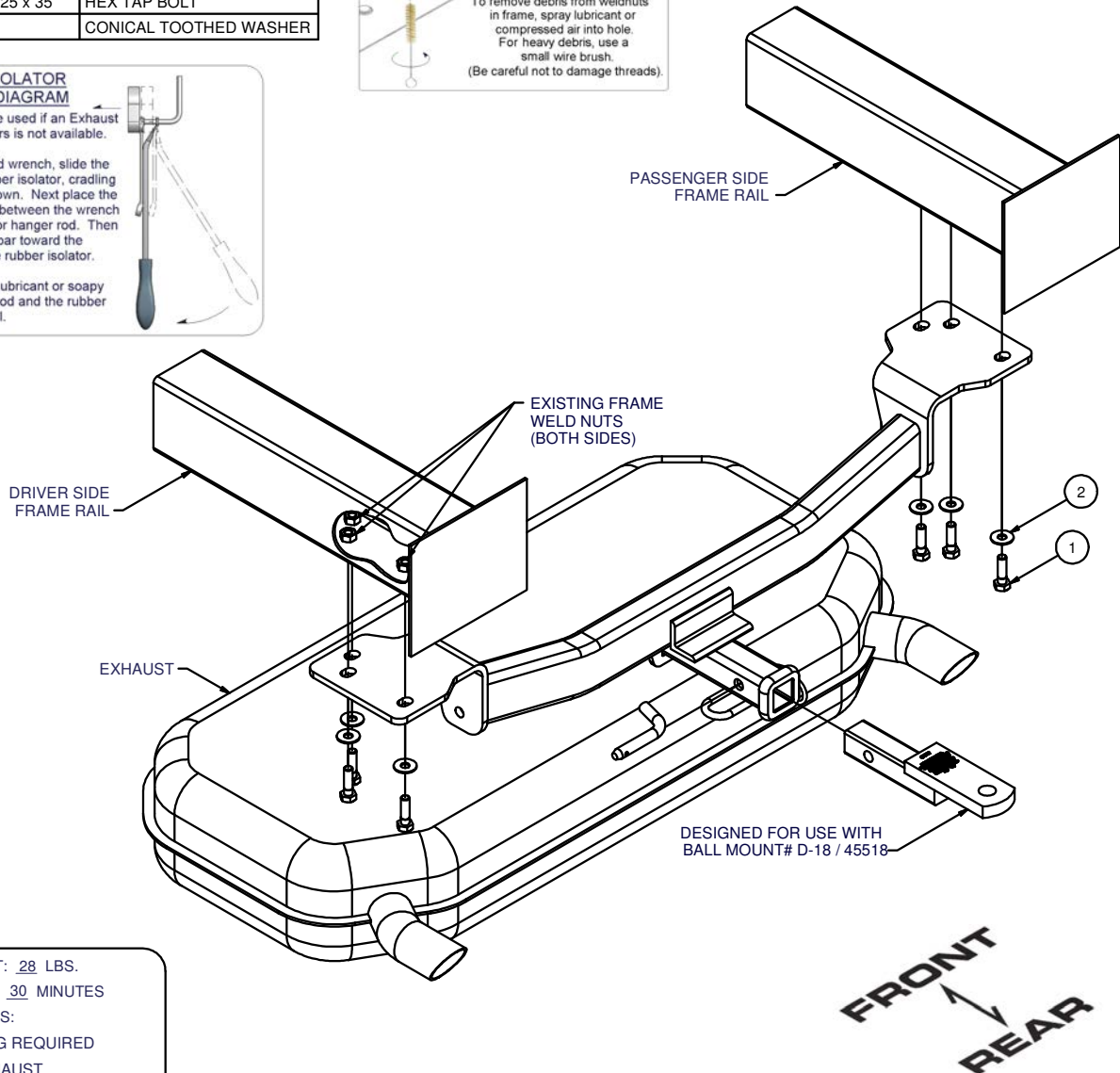

HITCH WEIGHT: 28 LBS.
 INSTALL TIME: 30 MINUTES
 INSTALL NOTES:
 - NO DRILLING REQUIRED
 - LOWER EXHAUST
 - REMOVE TOW HOOKS

INSTALLATION STEPS

- 1) Remove exhaust hangers and lower exhaust for ease of installation.
- 2) Remove tow hooks and return to customer.
- 3) Raise hitch into position and secure with hex bolts and conical washers through existing weldnuts in frame rails.
- 4) Torque all 10mm fasteners to 48 lb-ft.
- 5) Reinstall exhaust hangers removed in Step 1.

PERIODICALLY CHECK THIS RECEIVER HITCH TO ENSURE THAT ALL FASTENERS ARE TIGHT AND THAT ALL STRUCTURAL COMPONENTS ARE SOUND.



The **FIRST** Name
in Towing Products™

Trailer Hitches