

12923

MULTI - FIT CLASS II

GROSS LOAD CAPACITY WHEN USED AS A WEIGHT CARRYING HITCH: 3500 LBS. TRAILER WEIGHT & 350 LBS. TONGUE WEIGHT.  
**\*\*\*DO NOT EXCEED VEHICLE MANUFACTURER'S RECOMMENDED TOWING CAPACITY.\*\*\***

Parts List			
ITEM	QTY	PART NUMBER	DESCRIPTION
1	1	1/2"	FISHWIRE TOOL
2	4	1/2 - 13 x 1 1/2	HEX BOLT
3	4	1/2"	WASHER
4	6	1/2"	LOCK WASHER
5	6	1/2-13	HEX NUT
6	2	1/2-13 x 3 1/2"	HEX BOLT

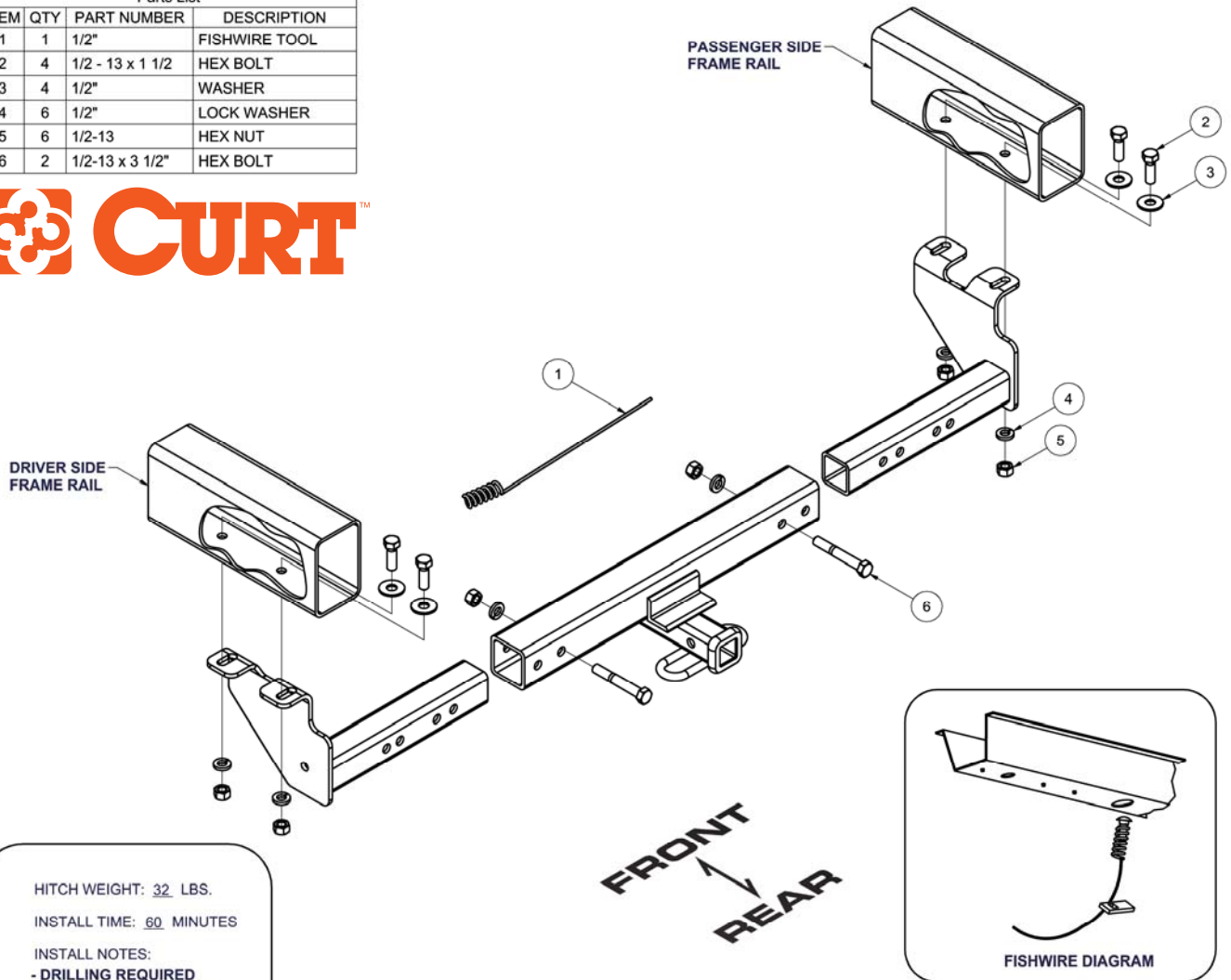

HITCH WEIGHT: 32 LBS.  
 INSTALL TIME: 60 MINUTES  
 INSTALL NOTES:  
 - DRILLING REQUIRED  
 - FISHWIRE FASTENERS

## INSTALLATION STEPS

- 1) To fit hitch on your vehicle's frame, see listing on page (2) for appropriate diagram letter (A)-(B)-(C)-(D)-(E)-(F), shown of page (2) using the appropriate holes shown.
- 2) Once appropriate holes are identified, assemble hitch as shown in the diagram above using 1/2" x 3-1/2" bolts, lockwashers and nuts.
- 3) Hold hitch up to frame and bolt using 1/2" x 1-1/2" bolts, flat washers, lock washers, and nuts.  
**(Note: some vehicles may require you to fishwire fasteners into position.)**

**Note:** Some vehicles require drilling of the frame. Raise hitch into position and center on vehicle frame. Mark and drill frame using a 9/16" drill.

**PERIODICALLY CHECK THIS RECEIVER HITCH TO ENSURE THAT ALL FASTENERS ARE TIGHT AND THAT ALL STRUCTURAL COMPONENTS ARE SOUND.**

**12923**

**MULTI - FIT CLASS II**

**VEHICLE FIT LIST – MAKE AND MODEL – DIAGRAM**

<b>Chevrolet</b>		<b>GMC</b>		<b>Ford</b>		<b>Dodge</b>	
S-10 Blazer	F	Pick Up, Full Size	B	Bronco	C	Caravan	D
S-10 Pick Up (88-90)	D	S-15 Jimmy	D	Bronco II	A	Dakota	E
S-10 Pick Up (91-93)	C	S-15 Pick Up (88-90)	C	Explorer	C	Pick Up, Full Size	C
Pick up, Full Size	B	S-15 Pick Up (91-93)	D	Pick Up, Full Size	C	Ramcharger	C
Suburban	C	Safari	F	Ranger Pick Up	A		
Venture Van	B	Suburban	C				
<b>Jeep</b>		<b>Nissan</b>		<b>Oldsmobile</b>		<b>Plymouth</b>	
Cherokee	C	Pick Up	E	Bravada	D	Voyager Van	D
Grand Wagoneer	C			Silhouette	B		
<b>Toyota</b>		<b>PONTIAC</b>					
Pick Up	E	Transport / Montana	B				

**Note:** On Ford Ranger and Chevy/GMC King Cab models, the spare tire must be entirely removed for installation. On other models, installation may be easier if spare tire is removed and reinstalled after hitch installation.

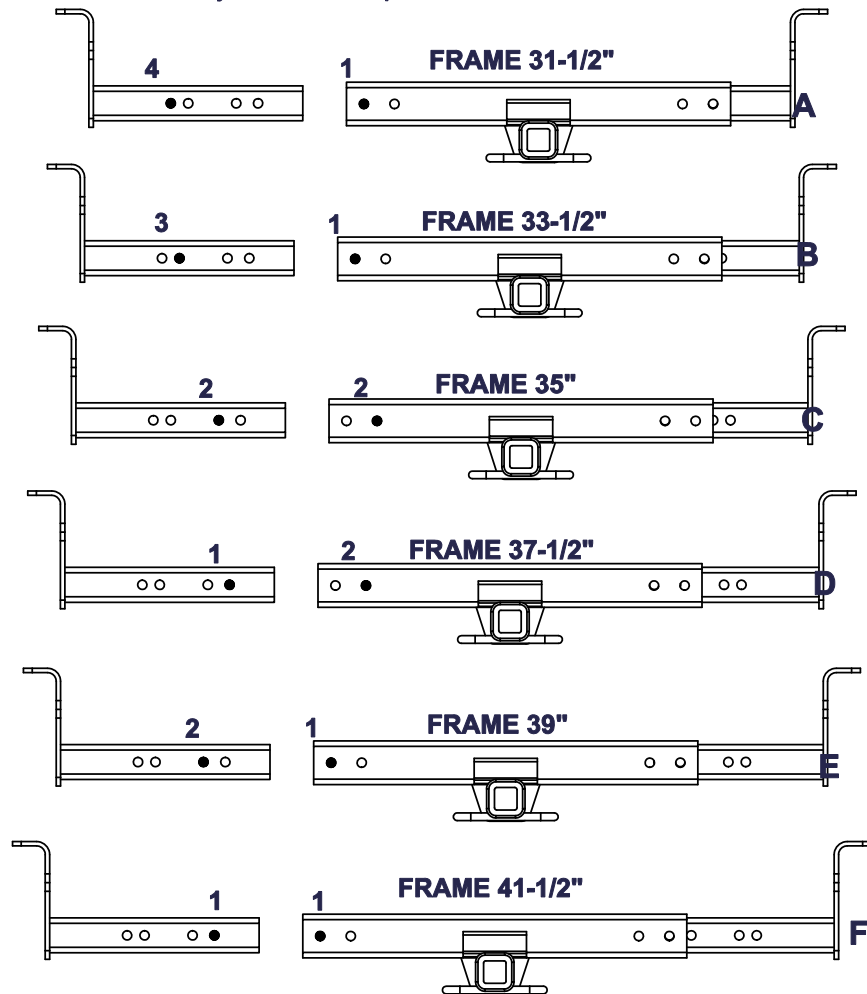

**PERIODICALLY CHECK THIS RECEIVER HITCH TO ENSURE THAT ALL FASTENERS ARE TIGHT AND THAT ALL STRUCTURAL COMPONENTS ARE SOUND.**