



**CAUTION: CAREFULLY READ INSTRUCTIONS BEFORE PROCEEDING**

## OVERVIEW

The LED Timing Light P/N 120001 includes a versatile controller and long life LED lamp intended for permanent installation and continuous operation on engine dyno systems.

- LED life estimated to be in excess of 400 hours with engine running at 1,500 RPM.
- Low cost capacitive spark pickup is used with conventional distributor, coil pack, and coil-near-plug ignition systems where a spark plug wire is accessible.
- Spark trigger sensitivity adjustment to accommodate different ignition energy levels while avoiding false triggering.
- Additional trigger inputs allow using the LED timing light with coil-on-plug ignition systems.
- High voltage trigger input allows triggering from COIL- signal for coil-on-plug ignitions without integrated coil drivers.
- Logic level (0-5V) trigger input allows triggering from coil drive signal for coil-on-plug ignitions with integrated coil drivers.
- Status LEDs for power and trigger signal.
- New Phillips Luxeon LED with narrow spot optics is pulsed at over 30 watts to provide brightness equal to or better than conventional Xenon flash tube based timing lights.
- LED lamp has 15" flexible gooseneck with 1/8-27 NPT male thread that allows easy mounting and alignment on any dyno frame.
- Black anodized aluminum controller housing and Delrin LED lamp housing.
- Industrial grade clamping terminal block on rear panel allows easy hookup.
- Compact size: controller is 3.3"L x 2.1"W x 0.9"H and LED lamp is 1.5" OD x 1.9"L.
- Operates from 12 VDC. Supplied with international power adapter for 110-240 VAC that includes four interchangeable plugs for worldwide operation.

## REPLACEMENT PARTS

The capacitive spark pickup P/N 120002 shown in Figure 5 may require replacement after extended use on multiple engines. Readily available commercial 75 ohm RG-59 coax cable with F connectors can be used by stripping approximately 1 foot of shielding from one end. Length of the cable is not critical.

The LED lamp P/N 12003 is also available as a replacement part (does not include the removable flexible gooseneck and a core return is required).

## INSTALLATION

1. Select convenient mounting locations for the controller and LED lamp. If you are using the capacitive spark pickup, make sure that the cable will reach cylinder 1 on the engines that you will be testing. You can mount the controller with hook and loop fastener material. A 2" x 3" piece of 3/8" thick phenolic or aluminum with a 1/8-27 NPT tapped hole makes a versatile mounting base for the LED lamp. This LED lamp base can then be secured on the dyno frame with a C-clamp.
2. If required, you can extend the connections for 12 VDC power and the LED lamp with 18 AWG stranded wire.
3. Refer to Figures 2-4 for hookup options. Use 18 AWG stranded wire for the dyno frame ground connection and keep this connection as short as possible. Most coil-on-plug ignition systems shown in Figure 4 fire the spark on the falling signal edge and will require installation of a jumper between the GROUND and TRIGGER INVERT terminals.
4. **Working with clamping terminal blocks.** All connections to the controller terminal block must be clearly identified either by means of distinct wire colors (such as shown in Figures 2-4) or wire labels. If you use different wire colors, mark up the figure for future reference. All connections can be made with 18-20 AWG wire. Wire should be stripped back 3/16-1/4 inch. No bare wire should be visible outside the terminal block. Use a miniature Phillips or flat screwdriver to tighten the screws.

---

## **WIRING OVERVIEW**

<b>Signal Connections (in order from top to bottom terminal blocks)</b>	
+12V POWER	Connects to the supplied AC adapter. The use of battery power is not recommended.
POWER GROUND	Connects to the supplied AC adapter. The use of battery power is not recommended.
LOGIC TRIGGER INPUT	Connects to logic level coil drive signal from ECM for coil-on-plug ignition systems with integrated driver. Compatible with systems using 3-5V logic high level.
HV TRIGGER INPUT	Connects to COIL- signal from ECM for coil-on-plug ignition systems without integrated driver. Triggers on 200-500V pulse when spark is fired.
GROUND	Logic ground connection.
TRIGGER INVERT	Jumper to GROUND as shown on Figure 4 for most coil-on-plug ignition systems with integrated driver for proper triggering on falling edge of signal.
TRIGGER OUTPUT	12V pulse with 750 microsecond duration for every trigger event. May be used as a tach signal for other instrumentation.
LED+	Connects to LED lamp red wire.
LED-	Connects to LED lamp black wire.
SIGNAL GROUND	Connects to dyno frame ground.

Figure 1 – LED Timing Light Controller and Lamp



Figure 2 – Hookup for Distributor or Coil Pack Ignition System with Spark Plug Wires

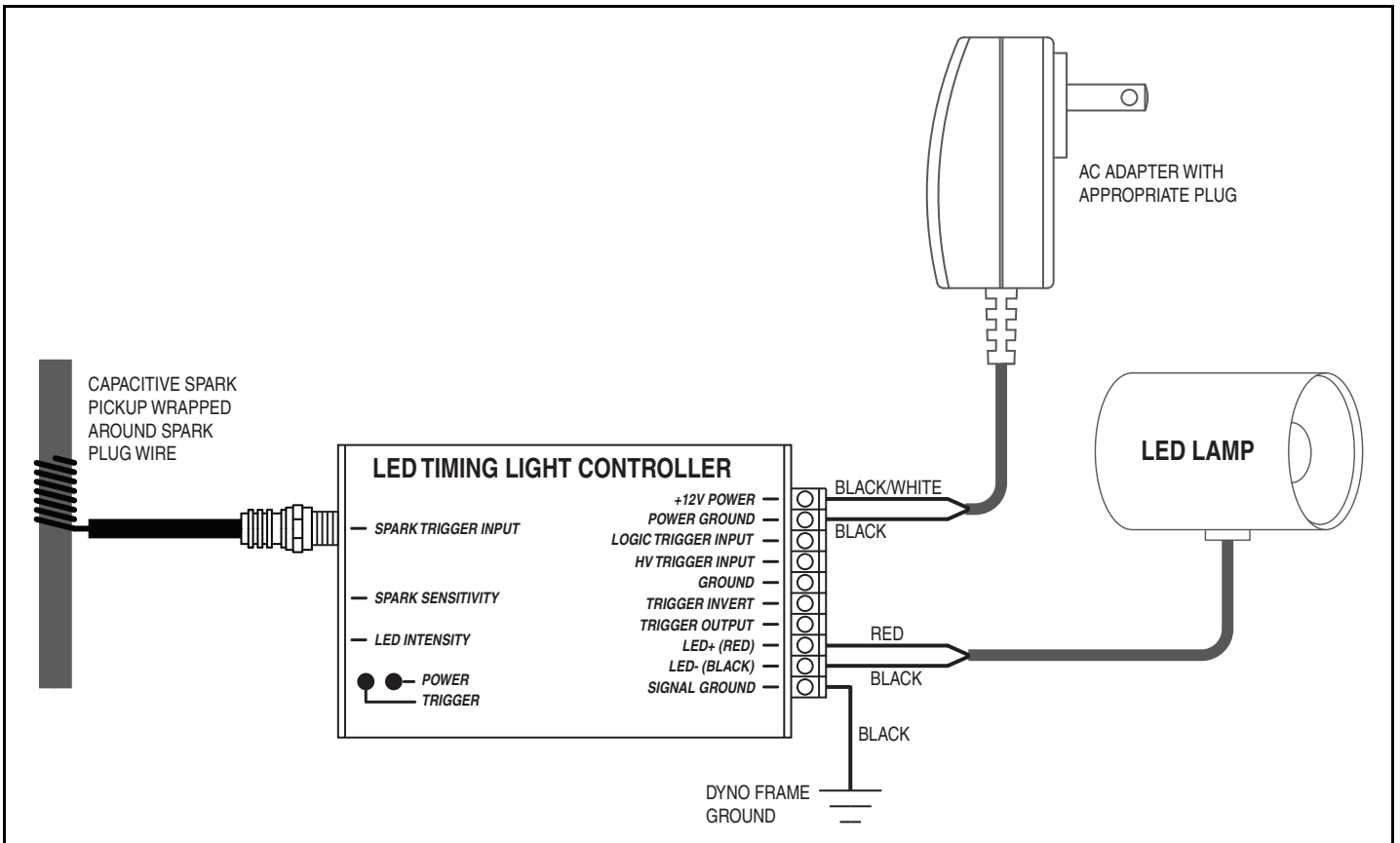

Figure 3 – Hookup for Coil-On-Plug Ignition System without Integrated Driver

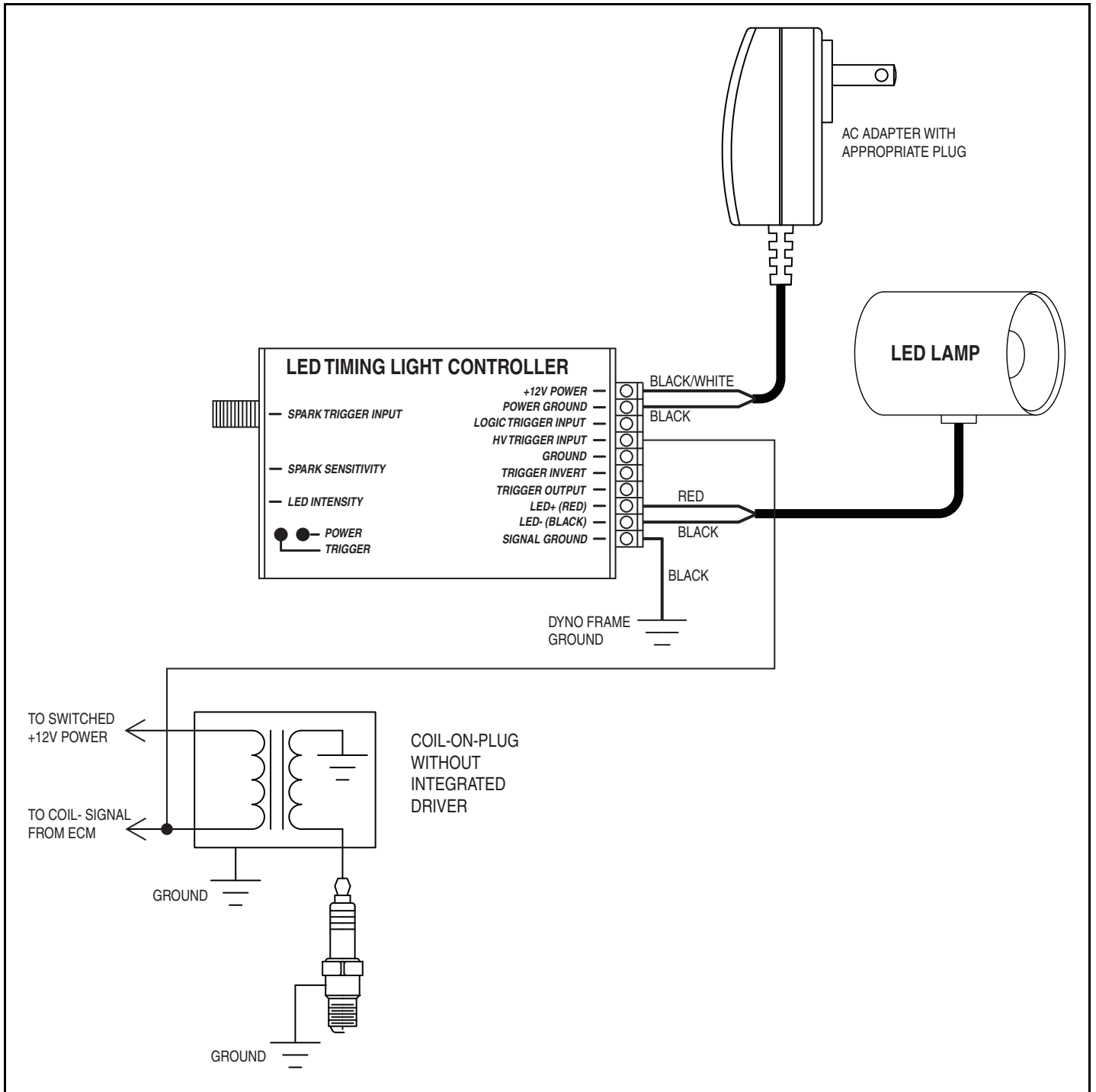
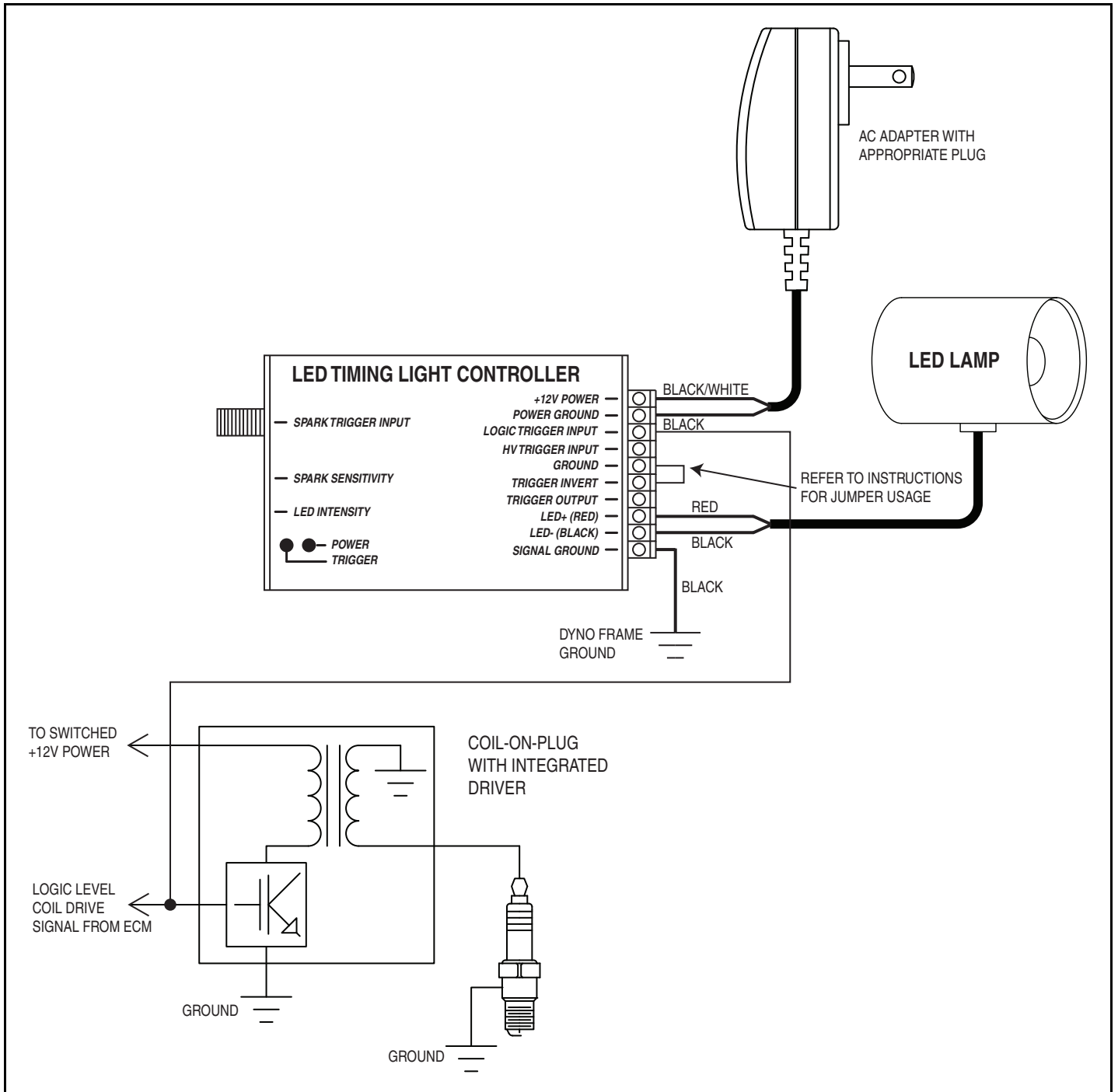

Figure 4 – Hookup for Coil-On-Plug Ignition System with Integrated Driver



**WARNING: Connecting the logic level input to a high voltage will damage the unit and void the warranty.**

---

Figure 5 – Capacitive Spark Pickup on Spark Plug Wire



---

## **OPERATION**

The controller has front panel trimpots for adjusting spark sensitivity (only applicable when using the capacitive spark pickup) and LED intensity (full counterclockwise turns off the LED). The trimpots rotate over a 270° range. Do not force them against the end stops. Start with both trimpots set midrange.

When using the capacitive spark pickup, set the spark sensitivity trimpot just above the point where the LED lamp flashes steady.

The timing mark will appear to spread out some and LED life will be slightly reduced at high LED intensity levels.

Two red LED indicators show power and trigger pulses. The trigger LED will blink (same as the LED lamp flashing) when trigger pulses are received.

## **CAPACITIVE SPARK PICKUP**

The capacitive spark pickup is a 75 ohm RG-59 coax cable with F connector on one end and 1 foot of shielding stripped from the other end.

The center conductor is wound around the cylinder 1 spark plug wire and secured with two tie wraps. The best location is near the spark plug. Start by securing one tie wrap about 1/2" from the end of the shield. Wrap the inner conductor tightly around the spark plug wire and secure the end with another tie wrap as shown in Figure 5. Direction of wrap is not important.

Route the pickup cable away from the spark plug wire at a 90° angle and keep it away from other spark plug wires. Route the cylinder 1 spark plug wire as far away as possible from other spark plug wires.

The pickup may not function correctly due to a weak signal when used with sleeved spark plug wires. Pull the sleeve back and wrap the pickup center conductor tightly around the spark plug wire itself.

Repeated flexing can cause the center conductor to crack. After installing the capacitive spark pickup, use a DVM to check for continuity from end-to-end in the center conductor and verify that the center conductor is not shorted to the shield at the F connector.

Some commercially available coax cables for CATV applications (typically labeled RG-8) will have double shielding with the inner shielding almost impossible to remove from the insulation on the center conductor.