





Dee Zee Running Board Installation Instructions

Congratulations on your purchase of a quality Dee Zee product. Dee Zee is recognized as having the highest quality running boards and accessories on the market today. We have earned this reputation by offering our customers a product they can be proud to place on their vehicles. Dee Zee meets all the criteria of manufacturing a custom-fit product which guarantees it to be the easiest product to install.

Note: Please take time to read all of the instructions before beginning this installation.

Cleaning instructions: To maintain the bright finish of your Dee Zee running board, clean with a mild detergent and use a high-grade automotive type wax. **DO NOT USE ABRASIVE CLEANERS ON THIS PRODUCT!**

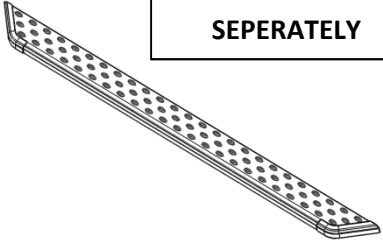
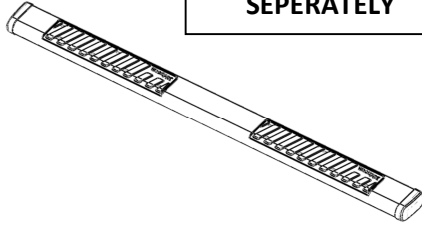
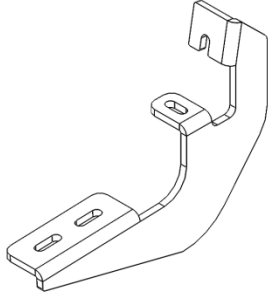
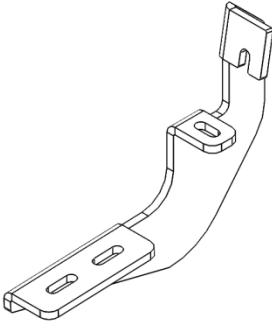
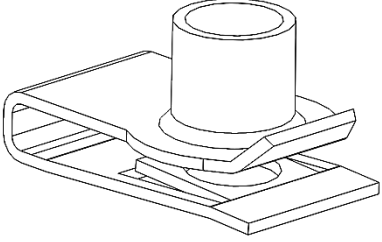
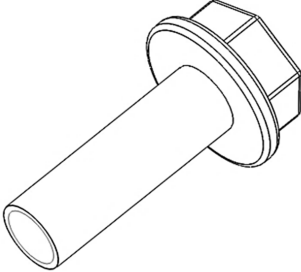
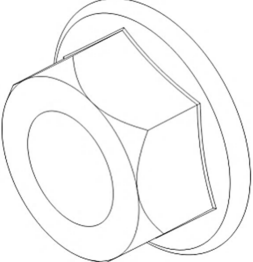
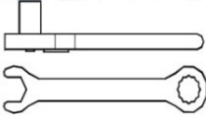
NXt Running Board / 6" Step Tube Installation Instructions DZ 16319 (2015-Current) CHEVY Colorado / GMC Canyon

<div style="border: 1px solid black; padding: 5px; margin-bottom: 10px;"> <p>A NXt Running Board</p> <p style="text-align: center;">***BOARDS SOLD SEPERATELY</p>  </div> <p>Various X2</p>	<div style="border: 1px solid black; padding: 5px; margin-bottom: 10px;"> <p>B 6" Oval Step Tube</p> <p style="text-align: center;">***TUBES SOLD SEPERATELY</p>  </div> <p>Various X2</p>	<div style="border: 1px solid black; padding: 5px; margin-bottom: 10px;"> <p>C Left Bracket</p>  </div> <p>B 2291LP X3</p>
<div style="border: 1px solid black; padding: 5px; margin-bottom: 10px;"> <p>D Right Bracket</p>  </div> <p>B 2291RP X3</p>	<div style="border: 1px solid black; padding: 5px; margin-bottom: 10px;"> <p>E 8mm U-nut</p>  </div> <p>PN 909 X12 X12 come with Step Tube</p>	<div style="border: 1px solid black; padding: 5px; margin-bottom: 10px;"> <p>F 8mm Hex Flange Bolt</p>  </div> <p>PN 527 X12 X12 come with Step Tube</p>
<div style="border: 1px solid black; padding: 5px; margin-bottom: 10px;"> <p>G 8mm Hex Flange Nut</p>  </div> <p>PN 526 X12</p>	<p style="text-align: center;">Tools Required</p> <div style="display: flex; justify-content: space-around; align-items: center;"> <div style="text-align: center;">  <p>Ratchet / Wrench 13mm</p> </div> <div style="text-align: center;">  <p>Straight Blade Screwdriver</p> </div> </div>	

1

Using a straight blade screw driver, pry the plastic caps out of the holes at the front location and both of the rear locations, as shown below. Both the Crew Cab and Double Cab have the same hole configurations.

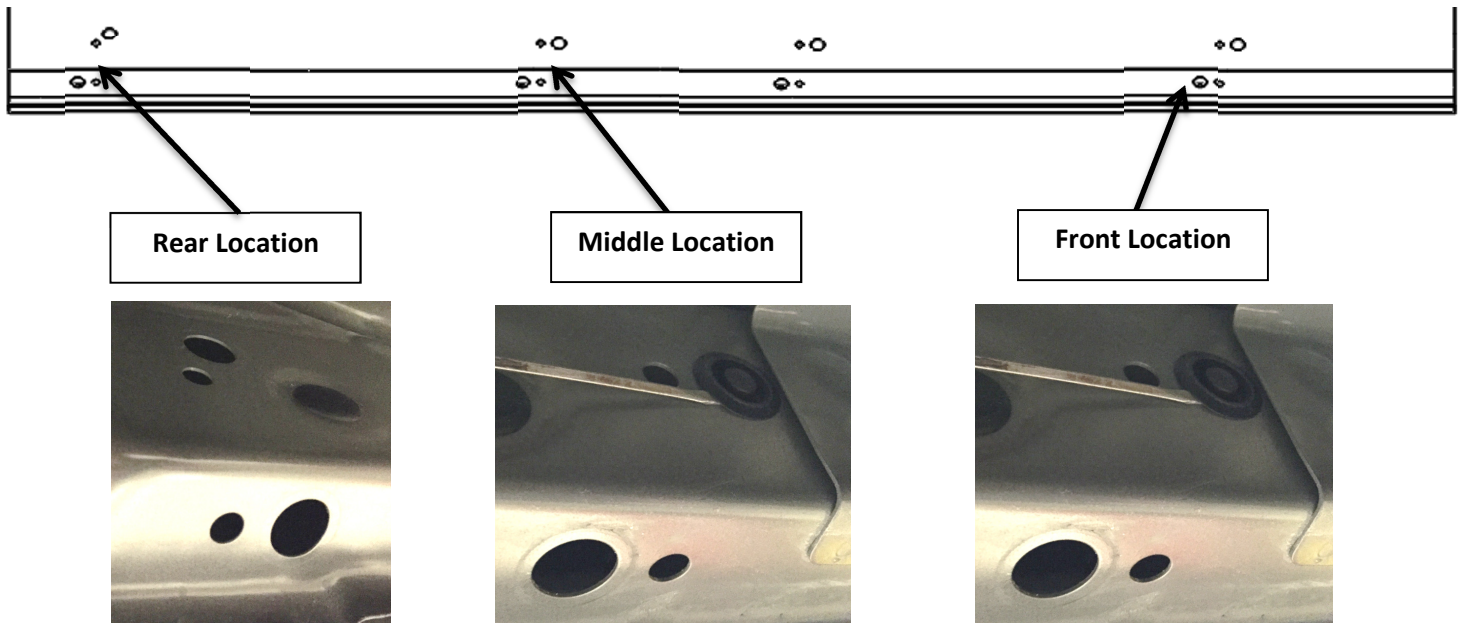

2

Install an 8mm U-nut (E) through each hole location that was covered by a plastic cap. To do this, insert the U-nut (E) into the hole and slide the U-nut (E) over so that the holes on the U-nut (E) and the vehicle are aligned, as illustrated below.

Front Driver's
Side Shown

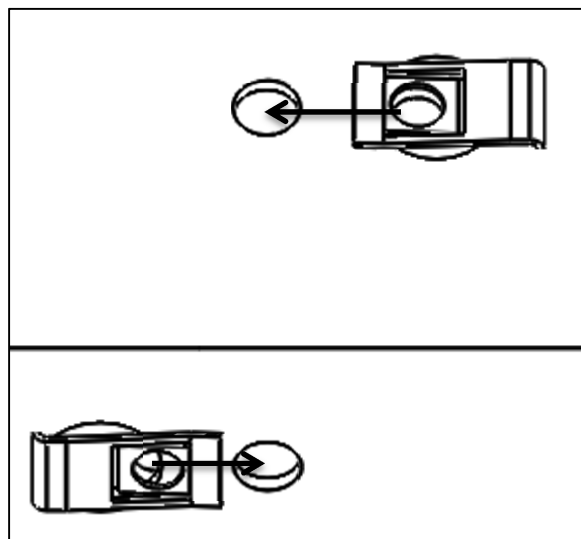

3

Attach a Right Bracket (C) to the Front Driver's Location, the Middle Passenger's Location, and the Rear Passenger's Location using two 8mm Hex Head Bolts (F) at each location. Do not completely tighten at this time.

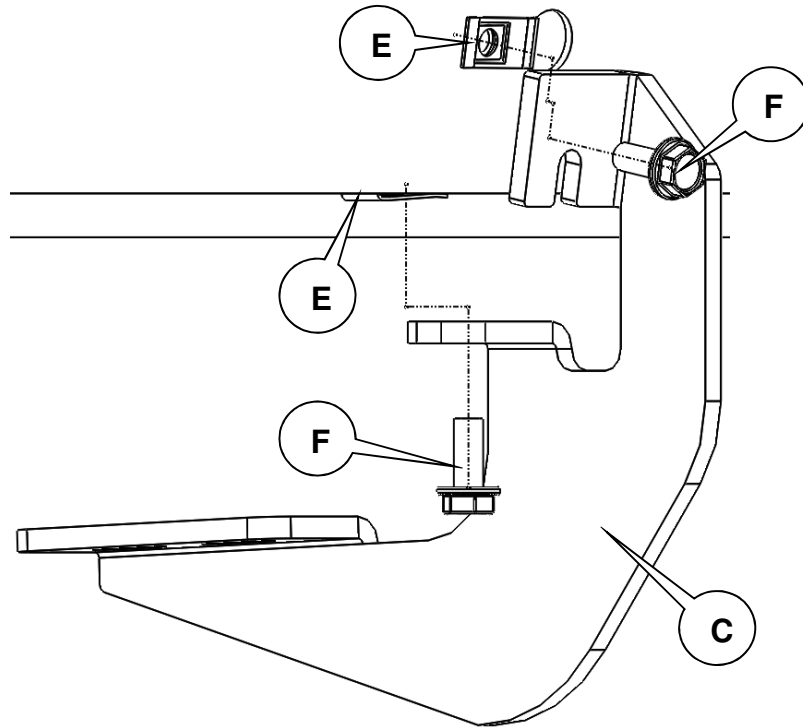

4

Attach a Left Bracket (D) to the Middle Driver's Location, the Rear Driver's Location, and the Front Passenger's Location using two 8mm Hex Head Bolts (F) at each location. Do not completely tighten at this time.

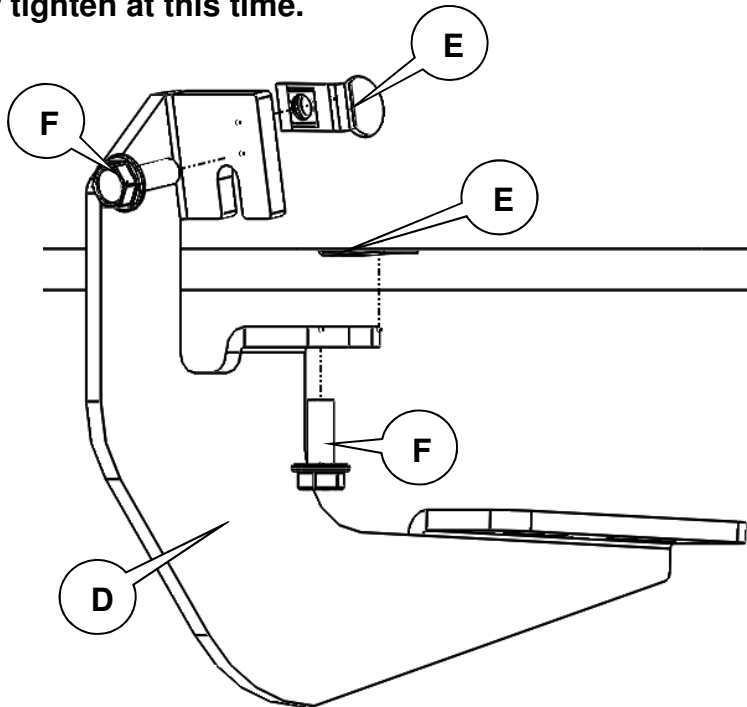

5a This step is for installing NXt Running Boards ONLY. Go to 5b for Step Tubes.

Attach the NXt Running Board (A) to the braces. Move the bolts that are attached in the channels of the board so that they are in the slots of the brackets. Attach the M8 Nuts (G) using a 13 mm ratchet or wrench to the bolts once they are through the slot. Do not completely tighten the nuts at this time. Repeat on other side.

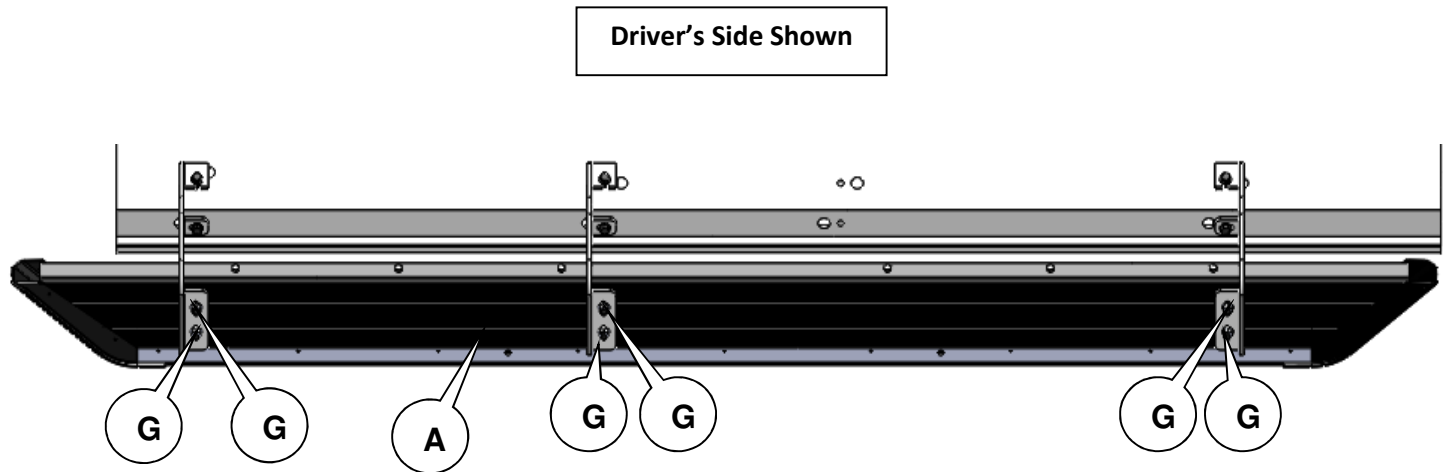

6a This step is for installing NXt Running Boards ONLY. Go to 5b for Step Tubes.

Adjust the board as necessary front to back. Once the board is in the desired location front to back, tighten the Nuts (G) that connect the board to braces. Repeat for other side.

Adjust the board as necessary up and down. Once the board is in the desired location up and down, tighten the Bolts (F) that connect the braces to the truck. Repeat for the other side.

5b This step is for installing 6" Oval Step Tubes ONLY. Go to 5a for NXt Running Boards.

Set the tube on the brackets and adjust as necessary front to back. Look under the tube to determine which sets of slots will be used to attach the tube to the braces.

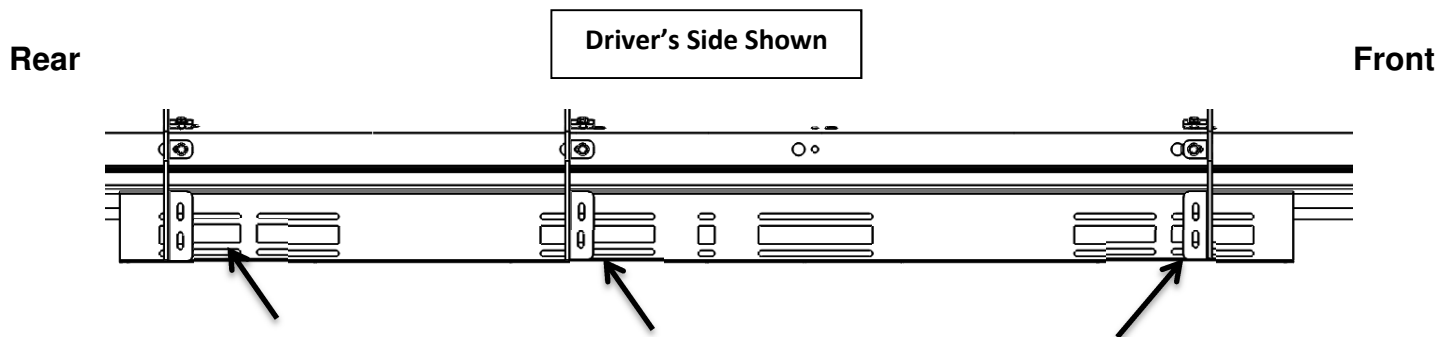

Remove the tube and install the 8mm U-nuts that came with the Step Tubes (J) into the slots identified above. Use 2 U-nuts per brace location. Repeat on other side

6b This step is for installing 6" Oval Step Tubes ONLY. Go to 5a for NXt Running Boards.

Attach the tube to the braces using the 8mm x 20 mm Bolt that came with the Step Tubes (F). Tighten bolts with a 13mm wrench or socket. Repeat for other side.

Adjust the tube as necessary up and down. Once the tube is in the desired location up and down, tighten the Bolts (F) that connect the braces to the truck. Repeat for the other side.