

Demco

BASEPLATE

Jeep Cherokee



Pin Height - 19" Pin Centers - 32-3/4"

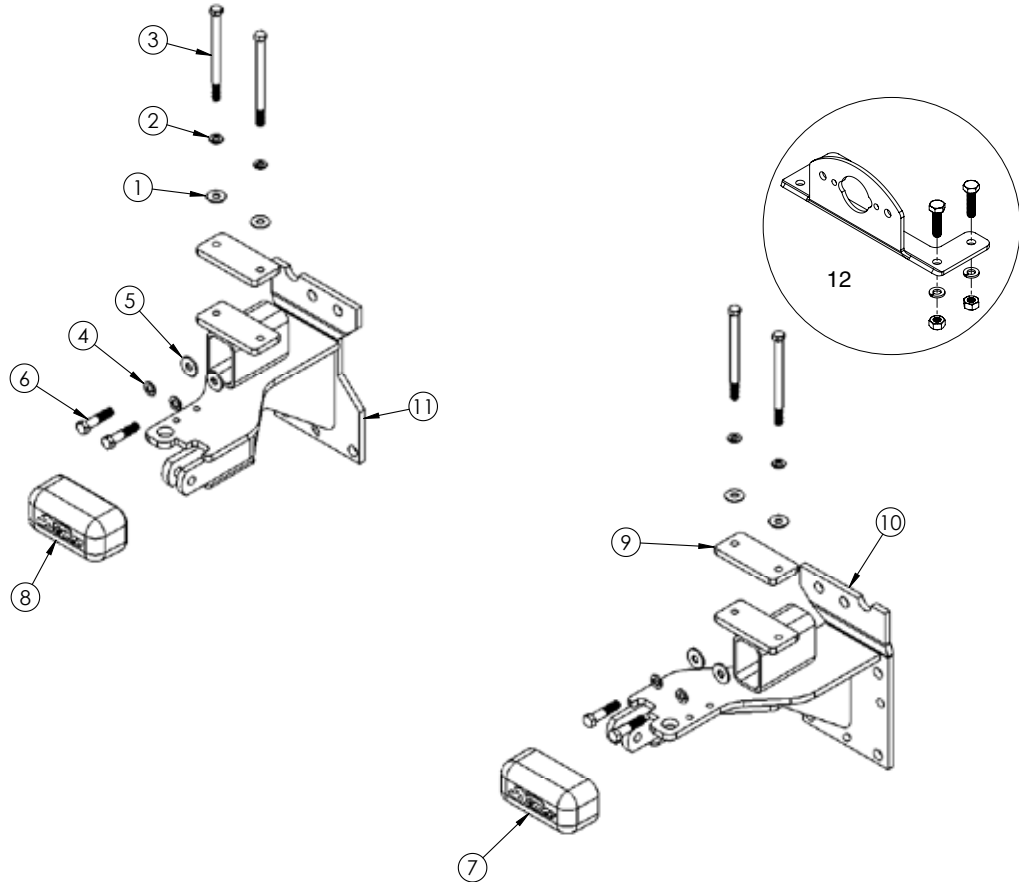

9518307 PARTS LIST

REF. NO.	PART NO.	QTY.	DESCRIPTION
1.	00059	4	3/8" Flat Washer
2.	00060	4	3/8" Lock Washer
3.	00675	4	3/8"NC x 5" Hex Bolt Gr.5
4.	07284	4	10mm Spring Lock Washer
5.	09229	4	10mm Fender Washer
6.	10746	4	10mm-1.25 x 50mm Hex Bolt Gr.8.8
7.	12979	1	Baseplate Pull Ear Cover "A"
8.	12980	1	Baseplate Pull Ear Cover "B"
9.	14802-76	2	Support Plate
10.	14803-76	1	Pull Pod Driver Side
11.	14804-76	1	Pull Pod Passenger Side
12.	5937	1	Plug Mount Kit
13.	12329	1	Loctite (not shown)
14.	14876	4	Avex Rivet (not shown)
15.	07490	4	1/2" Washer (not shown)

ASSEMBLY
OPERATION
REPLACEMENT PARTS

Please order replacement parts by **PART NO.** and **DESCRIPTION.**

READ complete manual *CAREFULLY*
BEFORE attempting operation.

Doing Our Best to Provide You the Best

WARNING: FAILURE TO FOLLOW THESE INSTRUCTIONS CAN RESULT IN LOSS OF TOWING VEHICLE CONTROL, SEPARATION OF THE TOW BAR FROM THE TOWING VEHICLE, SEPARATION OF THE TOWED VEHICLE FROM THE TOW BAR, CAUSING SEVERE PERSONAL INJURY, DEATH, OR PROPERTY DAMAGE.

 **CAUTION**

Safety is of utmost importance at all times. There are several items that must be checked each time before using and while using a tow bar.

Before allowing anyone to hook up or operate a tow bar, be sure they have read and understand the proper operating procedure.

DO NOT use worn or damaged cables and/or pins.

Be sure the **SAFETY CABLES** are hooked, chassis to chassis, to both the towing and towed vehicles using the crisscross method.

Check clearance between vehicles in a turning situation.

Check base plate mounting bolts for tightness and frame for metal fatigue.

Do not load the towed vehicle with anything as you may exceed the towing capacity of the tow bar.

Keep fingers away from pivot points to prevent personal injury.

Be sure the steering components of the towed vehicle are properly aligned.

Demco baseplates are designed for use on factory vehicle suspension setups. Demco baseplates are not recommended for use on modified suspensions lowered or raised. Towing vehicle must be larger and at least 500 lbs. heavier than the towed vehicle and tow bar combined.

NOTE: This unit can be backed up in moderate increments. Any severe backwards cornering could result in damage to the Tow Bar and/or towed vehicle chassis.

For automatic transmissions: Consult your vehicle owners manual for towing suitability with the drive shaft connected. Otherwise, the towed vehicle will have to be equipped with a transmission pump or drive shaft disconnect.

Check to make sure that all lights are in proper working order.

The information on towability of vehicles is reprinted with permission of MotorHome® Magazine, and is believed to be reliable. However, Demco does not warrant the information to be correct. Always consult your towed vehicle owner's manual and follow towing instructions. Each year, MotorHome® Magazine, compiles a list of vehicles that can be towed four-down behind a motorhome with no modifications required.

 **Caution: MotorHome® Magazine** left out any vehicles that have towing speed limits slower than 55 m.p.h., or distance limits of less than 200 miles. At a minimum, these vehicles require significant modification, such as the use of an aftermarket product, to make them towable. The availability of a **Demco Tow Bar Base Plate does not** imply that these vehicles can be modified or that there is an aftermarket product available. Refer to your vehicle owner's manual or consult your dealer to determine whether your vehicle can be modified to make it towable. Failure to observe this precaution could result in property damage or personal injury.

IMPORTANT INSTALLATION ITEMS

DEMCO products and accessories are intended to be installed by professional installers with experience, proper equipment and the ability to do modification work. Installers with these qualifications can be found in RV and Automotive Service Centers.

If the car to be towed has been in an accident, the chassis may be damaged in an area where the Base Plate attaches. It may no longer be suitable for towing. Extreme caution and careful examination are required in such a situation. It is also likely, even from a minor accident, that the hole alignment will be more difficult due to hole alignment problems.

Many DEMCO Base Plates are designed to use existing holes and hardware to mount the Base Plate to the towed vehicle. Even though the bolt is there, however, do not assume it is adequate for mounting the Base Plate. Manufacturers make many changes in hardware both within and between model years. Be sure the bolt is long enough to protrude past the nut a distance no less than 1/2 the diameter of the bolt, after the Base Plate is mounted. The threads should be in good condition. **We require that "LOCTITE® Blue" be used on all bolts.** If a new bolt is required, be sure it is SAE Grade 5 or Metric 8.8.

NOTE:
The dimensional variations between otherwise identical vehicles can be considerable. Some minor modifications may have to be made to ensure a proper fit.

BOLT TORQUE SPECIFICATIONS					
STANDARD BOLTS:			METRIC BOLTS:		
Size	Grade	Torque	Size	Grade	Torque
5/16"	5	18 ft/lbs	8mm	8	23 ft/lbs
3/8"	5	30 ft/lbs	10mm	8	45 ft/lbs
7/16"	5	50 ft/lbs	12mm	8	78 ft/lbs
1/2"	5	75 ft/lbs	14mm	8	125 ft/lbs

INSTALLATION INSTRUCTIONS

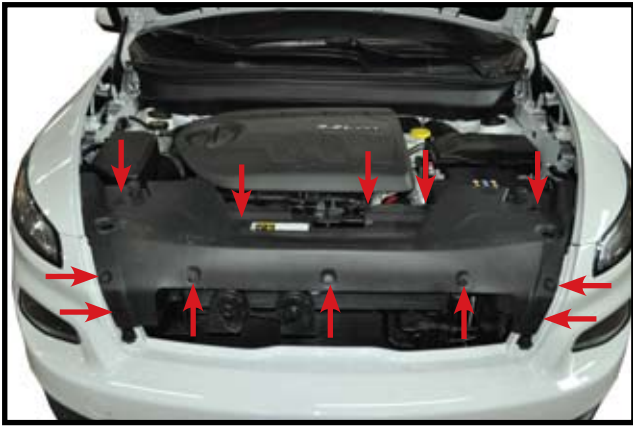

1. Open hood and remove twelve plastic push fasteners from top filler panel.



4. Drill out two aluminum rivets from front of each tire on the bottom of fascia using 3/16" drill bit.



2. Remove four screws and two plastic adjustment bolts from front of fascia. Remove three screws from each side just inside of fascia.



5. Remove nine bolts from skid panel and remove panel.



3. Remove three screws from the front of each wheel well. Release plastic clips that hold fender flares to fascia.



6. On each side remove one screw that attached the fascia to the fender. Pull out and forward to remove fascia. Unplug any wire connections that need to be unhooked to remove fascia.

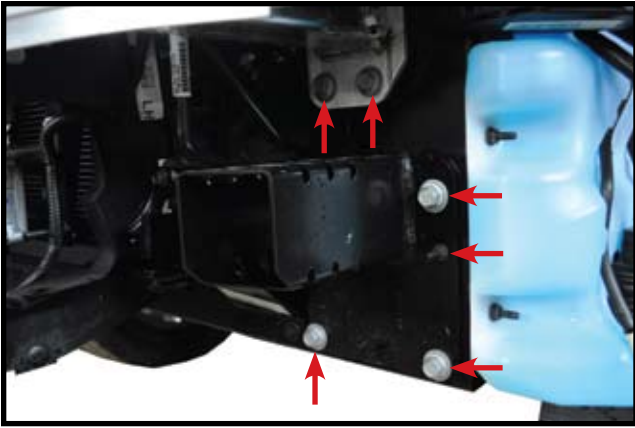

7. Remove three bolts and one nut from lower fascia support. Remove the bottom two bolts from the bumper they will not be reused. Repeat on other side.



9. Place top support plate on each side of bumper and using 3/8" x 5" bolts, lock washers, and flat washers. Tighten the support brace till baseplate is pulled tight to bottom of bumper. **NOTE:** Use Blue **LOCTITE**® on all bolts.

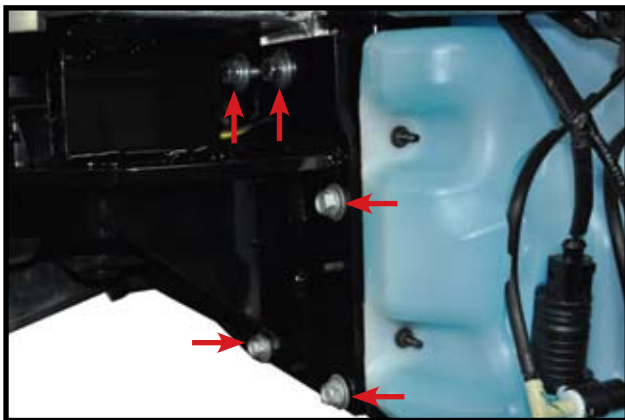

8. Reinstall the three bolts that were used on the lower fascia support. Install 10mm bolt, 10mm fender washer, and 10mm lock washer in lower bumper holes. Leave bolts loose for now. Repeat on other side. **NOTE:** Use Blue **LOCTITE**® on all bolts.

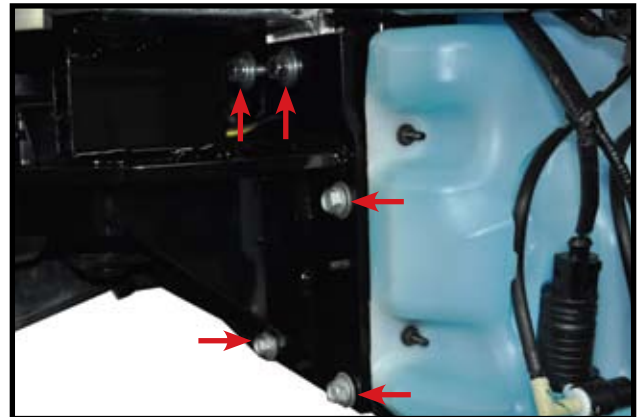

10. Tighten all bolts according to chart on front page in this order - bottom three, then lower bumper bolts, and then top support brace bolts.

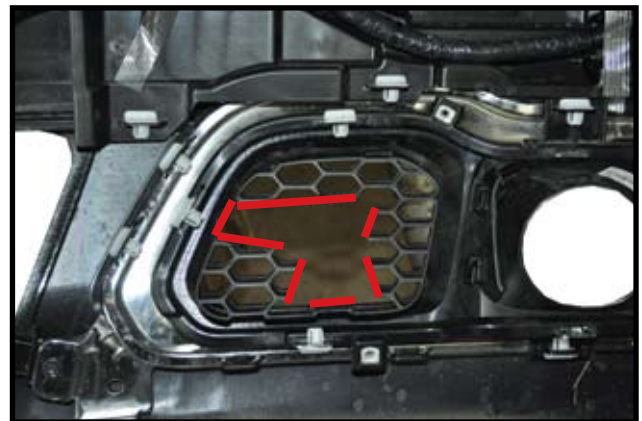

11. Trim lower grill as shown in picture. Trim as needed. **NOTE:** If equipped with active shutter system, trim solid plastic out behind grill webbing.



12. Replace facia and factory hardware in reverse order. Plug mount (item #12) may be installed if desired in convenience holes on either chain anchor or as desired. **NOTE:** Excess material may be trimmed from bracket.