

Thank you for your purchase of this Diode Dynamics Wiring Harness. Using standard Deutsch DT style connectors, this harness can be used for Stage Series LED Light bars, or other power supply needs. Basic installation instructions are included below. Please contact us if you have any questions.

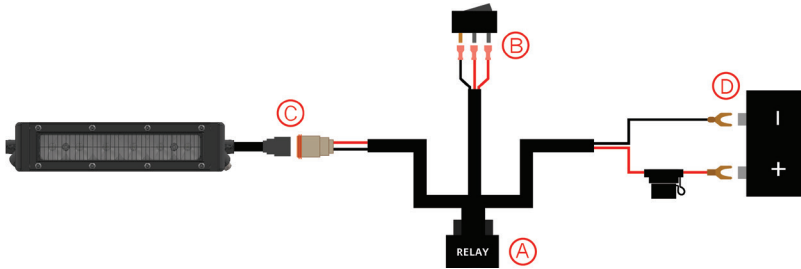

1. Determine a suitable location to mount the relay. (A) We recommend a location that is near the battery.
2. Determine a suitable location to mount the switch and route the switch to that location. This may require going through the vehicle's firewall. We recommend unplugging the toggle switch from the harness to route the wires more easily. Drill an appropriate-sized hole for the switch. Then reconnect the wires to the switch and mount it (B).
3. Connect the wiring harness to the light bar (C). Next, route the harness to the battery. Be sure to avoid areas with excessive heat buildup or moving parts. We recommend following the path of the vehicle manufacturer's wiring harness.
4. Connect the split ring terminals on the wiring harness to the battery (D). The black (ground) wire should be connected to the negative battery terminal and the red (power) wire should be connected to the positive battery terminal.
5. Test thoroughly and aim the light bar in the desired direction. ***Please check your local laws and regulations for aiming, installation, and applicability.***

Kit Includes: 18" LED Light Bar, Mounting Hardware, Deutsch DT Connector



Features

- Advanced TIR (total internal reflection) optics
- High intensity 6000K Lumileds LEDs
- Slim design, for easy mounting
- Durable aluminum extrusion
- Pressure equalizing vent to eliminate condensation

Specifications

- Input Voltage: 9-24VDC
- Input Power: 79.8 watts
- Current Draw: 5.7 amps @ 14V
- Operating Temperature: -40° to 185°F
- Weight: 3.2 lbs

Wiring

Connect the red wire to positive supply, and black wire to negative or common ground.

Please note: This auxiliary lamp draws high current, and requires adequately-sized wiring for safe operation. If you are not using a Diode Dynamics wire harness, use wire sized 16 AWG or larger. Please be mindful of current ratings and wire size, especially if splitting power signals to multiple light bars, or using switches. If you have any questions, please feel free to contact us for assistance.

Mounting

If you wish, you may use the included hardware to mount your light bar. A number of fasteners are included, and can be used as you see fit. The most common mounting style is shown below. Stage Series Light Bars are also compatible with most standard mounting brackets on the market. Reference the dimensions on opposite side to determine the best mounting solution for your application.

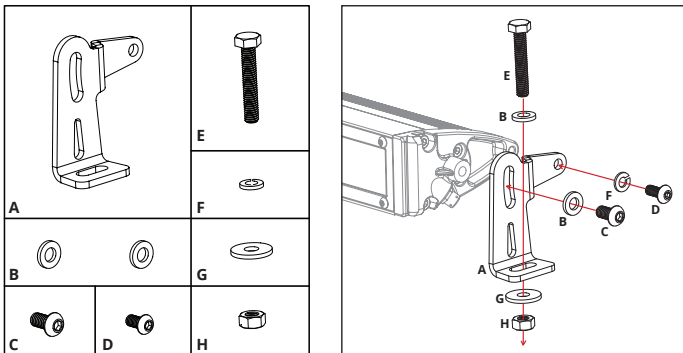

Dimensions

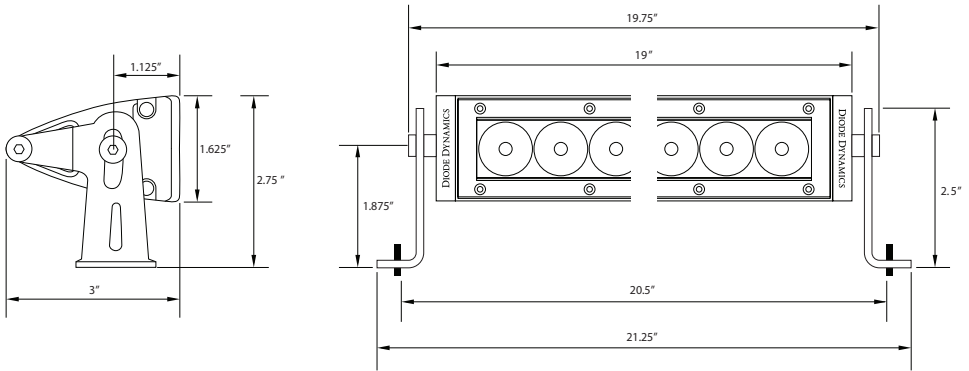

Output

Driving

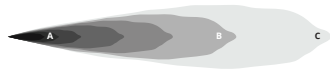

Flood

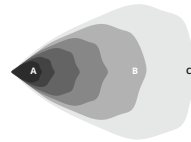

Combo

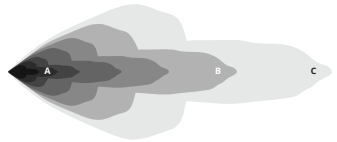

- A - lux at 10 meters
- B - Distance (m) with 1 lux
- C - Distance (m) with .25 lux

SS ₁₈ 18" Light Bar		A	B	C		
Lens Color/Optics	cd*	Illuminance (lx)			Measured Output	Output Color
White Driving	165,000	1,650	406	810	4,200 lumens	6000K White
White Flood	6,000	60	77	150	4,200 lumens	6000K White
White Combo	99,500	1,120	315	630	4,200 lumens	6000K White
Amber Driving	99,000	990	315	630	2,400 lumens	2000K Amber
Amber Flood	3,600	36	60	120	2,400 lumens	2000K Amber
Amber Combo	47,800	672	219	440	2,400 lumens	2000K Amber

This installation guide is for the following SKU:

DD5016 SS18 White Driving Light Bar
 DD5030 SS18 White Combo Light Bar
 DD6034 SS18 White Flood Light Bar

DD5038 SS18 Amber Driving Light Bar
 DD5052 SS18 Amber Combo Light Bar
 DD6042 SS18 Amber Flood Light Bar



Specifications

LENS COLOR/OPTICS	PEAK BEAM INTENSITY (CANDELA)	ILLUMINANCE (LUX @ 10M)	MEASURED OUTPUT (LUMENS)	RAW OUTPUT (LUMENS)	OUTPUT COLOR
White Driving	165,000 cd	1,650 lux	4,200 lm	6,840 lm	6000K White
White Combo	99,500 cd	315 lux	4,200 lm	6,840 lm	6000K White
White Flood	6,000 cd	77 lux	4,200 lm	6,840 lm	6000K White
Amber Driving	99,000 cd	315 lux	2,400 lm	3,420 lm	2000K Amber
Amber Combo	47,800 cd	219 lux	2,400 lm	3,420 lm	2000K Amber
Amber Flood	3,600 cd	60 lux	2,400 lm	3,420 lm	2000K Amber

Color Temp (CCT): 2000K

Beam Angle: Driving, 20°x8°, Combo (Driving and Flood), Flood, 80°x50°

Power (watts): 79.8

Operating Voltage: 9-16V

Current (amps @ 13.2V): 5.7

Polarity: Polarity Specific

Operating Temperature: -40C to 85C (-40F to 185F)

LED Emitter: Luxeon Z ES

Connector(s): Deutsch DT Input

Materials: Aluminum PCB, Polycarbonate Lens, Aluminum Heatsink

Cooling: Passive, heatsink

Intrusion Ratings: IP68 Waterproof

Product Dimensions (in): 19x3x1.63 If you would like CAD for your project, please contact us.