

Aiming Instructions

12. Park your vehicle 25 feet away from a wall or garage door on a level surface.
13. Loosen the 5/32" allen bolts on each side of your SS3 pod, just enough to allow you to adjust the pod.
14. On your vehicle, measure the distance between the ground and the center of your SS3 pod. This is your mounting height.
15. Mark the mounting height on the wall or garage door using tape.
16. Add another piece of tape four inches below the mounting height. This is your fog light cutoff line.
17. Aim your SS3 pods on each side, so that the top of the beam pattern is on the cutoff line mark.
18. Tighten the 5/32" allen bolts back down. Do not overtighten or use power tools to torque them down.
19. Use the included rubber grommets to cover the adjustment screws.
20. Replace the shroud, upper bumper piece, fender flare, and fender liner using the original hardware to complete the installation.

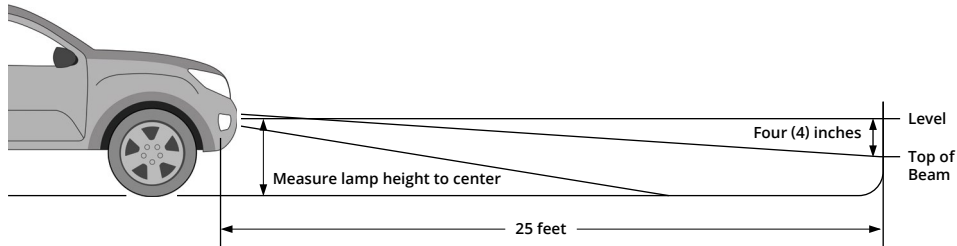

This installation guide is for the following SKUs:

DD6237 Worklight SS3 Sport Type F2 Kit White SAE Driving
DD6238 Worklight SS3 Sport Type F2 Kit White SAE Fog
DD6240 Worklight SS3 Sport Type F2 Kit Yellow SAE Fog
DD6241 Worklight SS3 Pro Type F2 Kit White SAE Driving

DD6242 Worklight SS3 Pro Type F2 Kit White SAE Fog
DD6244 Worklight SS3 Pro Type F2 Kit Yellow SAE Fog
DD6694 Worklight SS3 Max Type F2 Kit White SAE Fog
DD6695 Worklight SS3 Max Type F2 Kit Yellow SAE Fog

STAGE
SERIES
 RALLY-QUALIFIED LED LIGHTING

SS₃ 3" LED Pod
 Type F2 Foglight Kit



Thank you for your purchase of our new SS3 Type F2 Foglight Kit. CAD-designed to use existing mounting points, this kit is compatible with the 2015+ F-150 and 2017+ F-250/F-350 models. Basic installation instructions are included below. **Please contact us if you have any questions.**

COMPUTER DESIGNED
OEM FITMENT

ASSEMBLED IN
USA

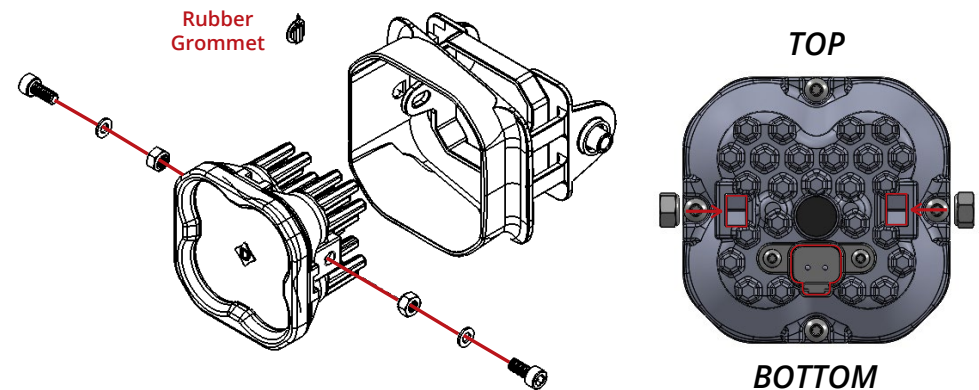

Passenger/Right Side (opposite for driver/left side)

1. Install the supplied nuts into the pod housing with the nylon facing inward. Attach the bracket to the pod using the supplied screws and washers. Make sure the bracket is in the correct orientation. There will be a small gap between the pod and bracket to allow for aiming. See diagrams above. Ensure that the screws are tightened such that the pod retains its position, but can pivot with force for aiming.

See inside for further instructions.



2. Peel back the wheel well fender liner. To do so, remove the two push clips, two 5.5mm bolts, and two 7mm bolts shown in the picture to the left and peel the fender liner back.



3. Peel the plastic fender flare back using a plastic trim removal tool. Loosen the plastic clips holding it in place using a pick tool.



4. Using a plastic trim removal tool, loosen the upper bumper piece. Repeat the steps on the other side of the vehicle to remove the upper bumper piece from the vehicle.



5. Remove the shroud blocking access to the fog light bezel. To do so, remove the 10mm bolt and loosen the three plastic pins holding the shroud to the bottom of the headlight. Then remove the two 10mm bolts near the fender flare. Remove the shroud from the vehicle.

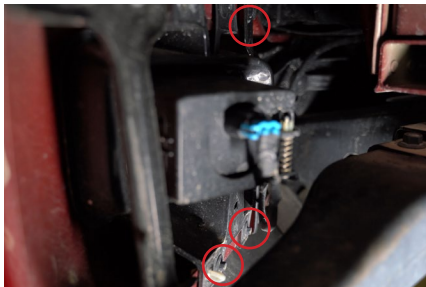

6. Remove the fog light bezel from the bumper, by removing the three 8mm bolts holding it in place and disconnecting the fog light harness. If applicable, remove the two 13mm bolts holding the bracket blocking the fog light bezel in order to gain access to the fog light bezel.

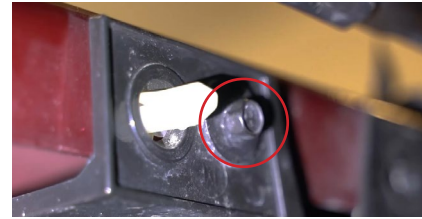

7. Remove the final 8mm bolt and loosen the plastic retaining clip to remove the fog light bezel from the vehicle.

NOTE: You may need to loosen the two 15mm bolts on the crash bar to give yourself enough room to remove the fog light bezel.



8. Remove the fog light housing from the bezel. To do so, remove the adjustment screw and spring from the fog light housing. Remove the factory fog light housing by prying up on the retainer clips holding it in place.

NOTE: The adjustment screw won't be reused.



9. Install the SS3 bracket on to the factory bezel by flexing the retainer clips on the bezel as required.

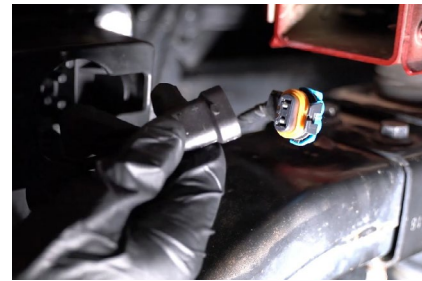

10. Reinstall the factory fog light bezel, by reinstalling the factory hardware. Plug the SS3 into the factory fog light harness using the included DT wire adapter. Test function. If the light does not turn on, try flipping the connector 180°.

11. Repeat the steps on the other side of the vehicle.

See back for aiming instructions.



Learn more about off-road lights we have.