

## Applications:

Years	Make	Models
2017-Current*	KIA	Sportage

## Installation Time: 25 min

The time listed above is the average time for professional installers. If you do not feel comfortable performing this installation on your own or are in need of assistance, please contact a professional installer.

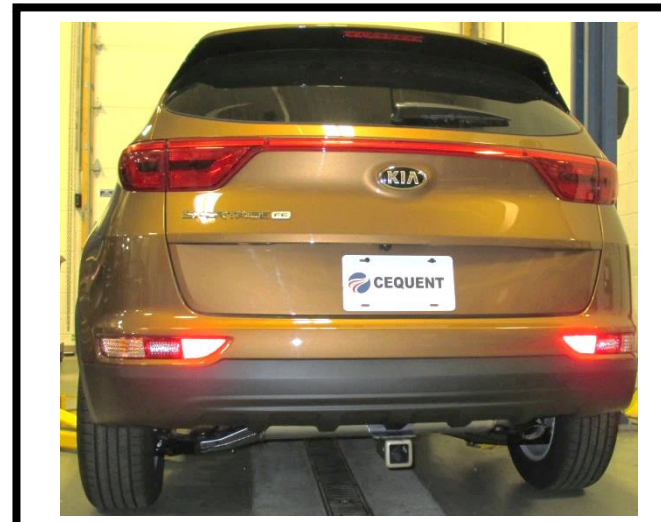

Representative Vehicle Photo

## Equipment Required:

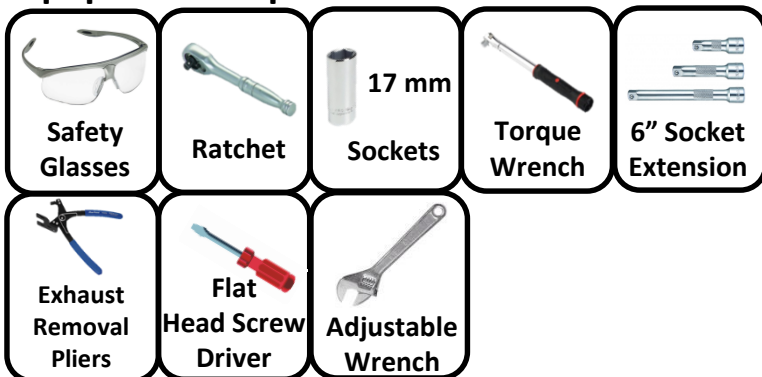

**DO NOT EXCEED LOWER OF TOWING VEHICLE  
MANUFACTURER'S RATING OR:**

Hitch Type	Max Gross Trailer Weight	Max Tongue Weight
Weight Carrying	4500 lb. (2043 kg)	675 lb. (306 kg)
Weight Distributing	4500 lb. (2043 kg)	675 lb. (306 kg)

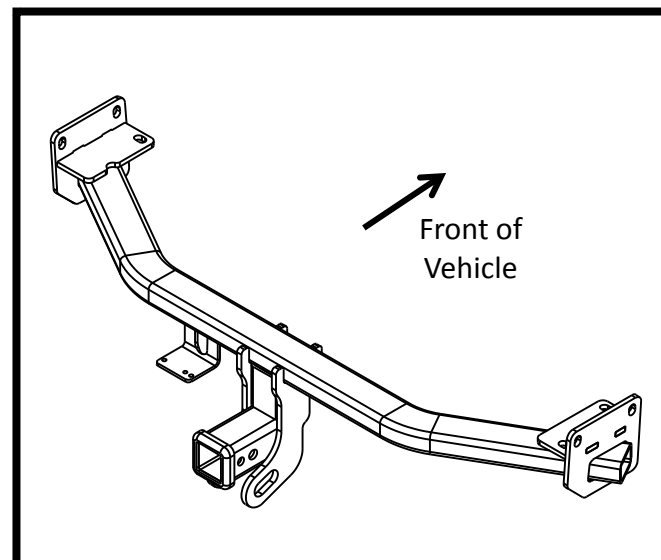



Hitch Illustration

**Always wear SAFETY GLASSES when installing hitch**

# Installation Instructions

## PART NUMBERS: 76074, 84074, CQT76074

**Fastener Kit: 76074F**

①	Qty. (7)	Bolt M10 X 1.25 X 30mm CL10.9	
②	Qty. (7)	Conical Tooth Washer 3/8"	

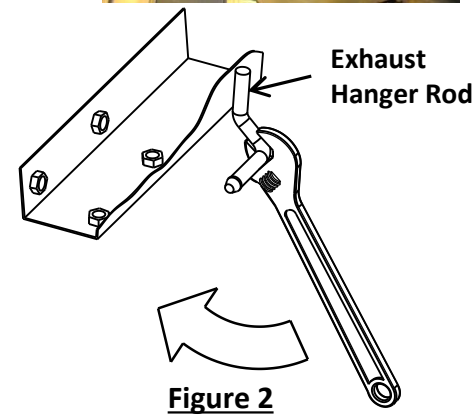
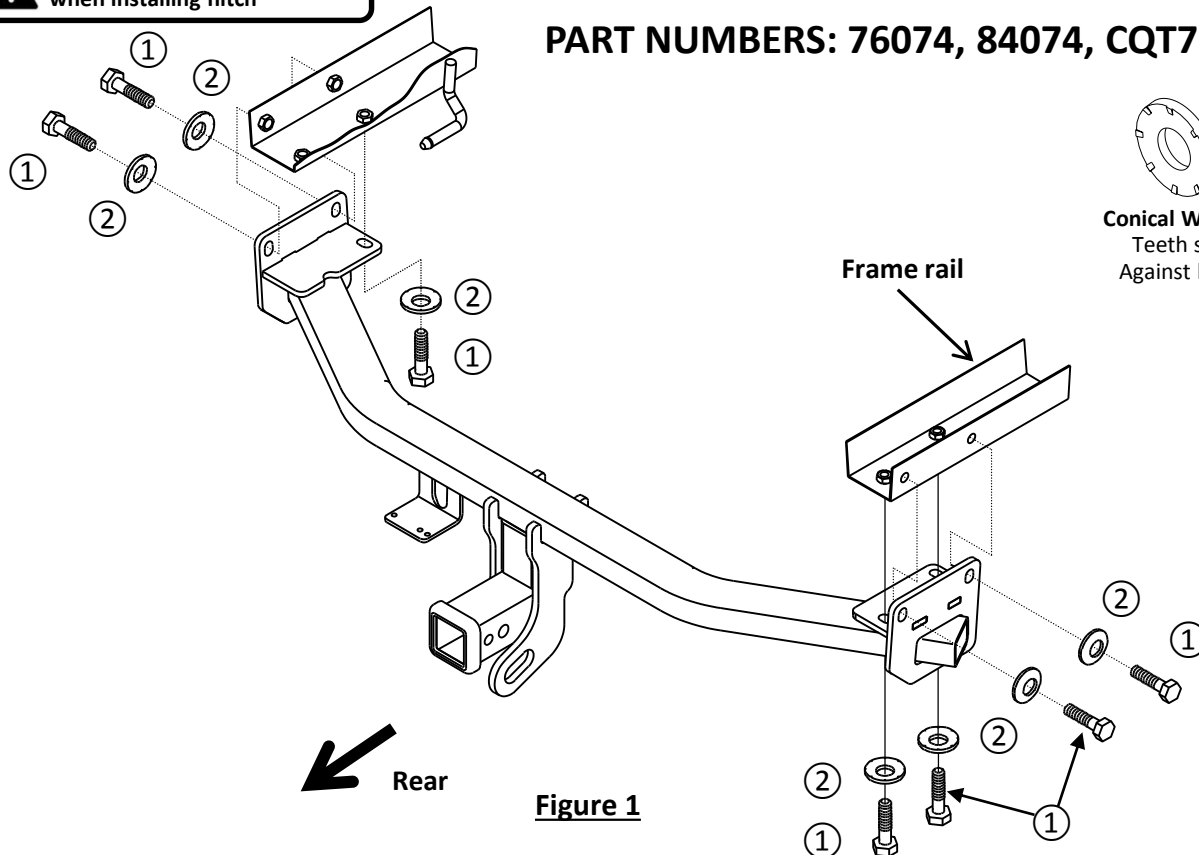

**Figure 1**

**Figure 2**

- Lower muffler** – Lower muffler by removing the (2) rearmost rubber hangers. **Note:** A spray a lubricant on rubber hangers makes them slide off metal pins more easily. **NOTE:** Be careful that exhaust is supported before removing rubber hangers.
- Remove underbody appearance panels (if present)** – remove (2) plastic underbody appearance panels, (1) each side, located under the rear bumper and behind the rear wheels. Using a standard screwdriver, remove the plastic push rivets from each panel and pull down to remove the panels from plastic push nuts. Set aside for reinstallation later.
- Raise hitch into position** – raise the hitch over the tailpipe(s) and align holes in hitch with existing weldnuts in frame rail.
- Install fasteners** - Install (7) M10 bolts and conical toothed washers as shown in figure 1.
- Tighten all M10 CL10.9 fasteners with torque wrench to 42Lb.-Ft. (57N\*M)**  
 ⚠ Proper torque is needed to keep the hitch secure to the vehicle when towing.
- Raise muffler** – raise muffler back into position and reattach rubber hangers, (1) per side.
- Modify Exhaust Hangers** – If additional clearance between muffler and hitch is required, bend (2) metal exhaust hanger rods down, (1) hanger, each side. **See Figure 2.**
- Reinstall plastic appearance panels (if present)** – Using existing fasteners, reinstall (2) plastic appearance panels removed in Step 2.

Note: check hitch frequently, making sure all fasteners and ball are properly tightened. If hitch is removed, plug all holes in trunk pan or other body panels to prevent entry of water and exhaust fumes. A hitch or ball which has been damaged should be removed and replaced. Observe safety precautions when working beneath a vehicle and wear eye protection. Do not cut access or attachment holes with a torch.

This product complies with safety specifications and requirements for connecting devices and towing systems of the state of New York, V.E.S.C. Regulation V-5 and SAE J684.

1. **Lower muffler** – Lower muffler by removing the (2) rearmost rubber hangers. **Note:** A spray a lubricant on rubber hangers makes them slide off metal pins more easily. **NOTE:** Be careful that exhaust is supported before removing rubber hangers.



2. **Remove underbody appearance panels (if present)** – remove (2) plastic underbody appearance panels, (1) each side, located under the rear bumper and behind the rear wheels. Using a standard screwdriver, remove the plastic push rivets from each panel and pull down to remove the panels from plastic push nuts. Set aside for reinstallation later.



3. **Raise hitch into position** – raise the hitch over the tailpipe(s) and align holes in hitch with existing weldnuts in frame rail.



4. **Install fasteners** - Install (7) M10 bolts and conical toothed washers as shown in figure 1.

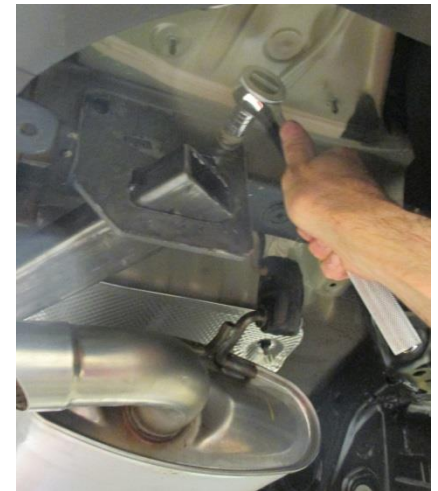
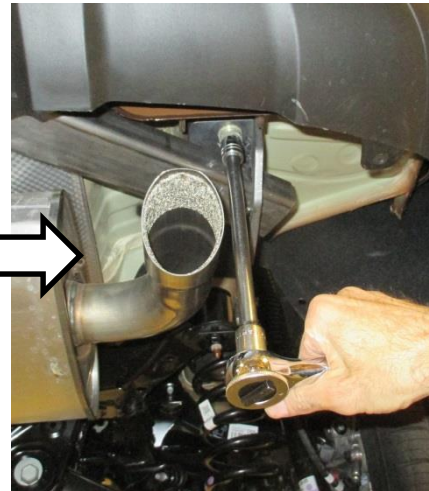

5. **Tighten all M10 fasteners with torque wrench to 42lb.-Ft. (57N\*M)**

 Proper torque is needed to keep the hitch secure to the vehicle when towing.



6. **Raise muffler** – raise muffler back into position and reattach rubber hangers.

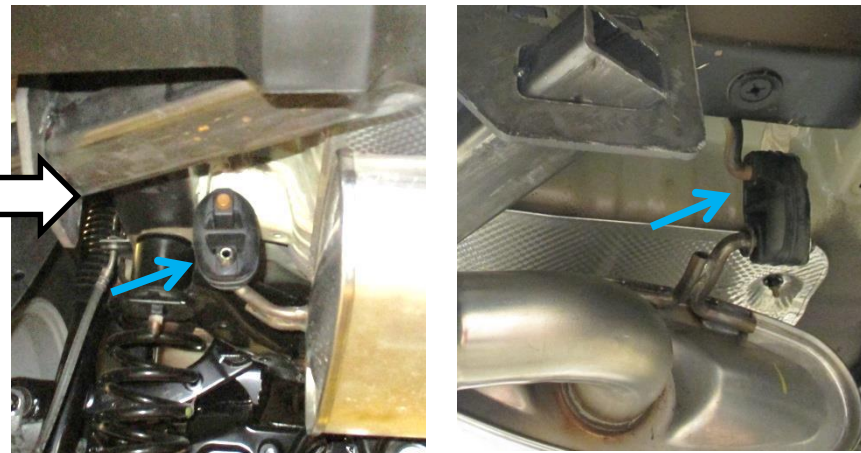

7. **Modify Exhaust Hangers** – If additional clearance between muffler and hitch is required, bend (2) metal exhaust hanger rods down, (1) hanger, each side. **See Figure 2.**

8. **Reinstall plastic appearance panels (if present)** – Using existing fasteners, reinstall (2) plastic appearance panels removed in Step 2.

