

# Installation Instructions

## GOOSENECK RAIL MOUNTING KIT

Dodge Ram 2500/3500 Heavy Duty  
Short & Long Bed, All Megacabs

**Part Numbers:**

**4457**

### 9464/9474 HIDE-A-GOOSE HITCH INSTALLATION

**If using this 4457 Rail kit with 6300 or 8339 above bed gooseneck hitches start on Page 5.**

**Equipment Required:**

- Fastener Kit:** 4457F
- Wrenches:** 3/4, 15/16, 10mm
- Drill Bits:** 1/4", 5/8"
- Other Tools:** Drill, Tape

**WARNING:** Under no circumstances do we recommend exceeding the towing vehicle manufacturers recommended vehicle towing capacity.

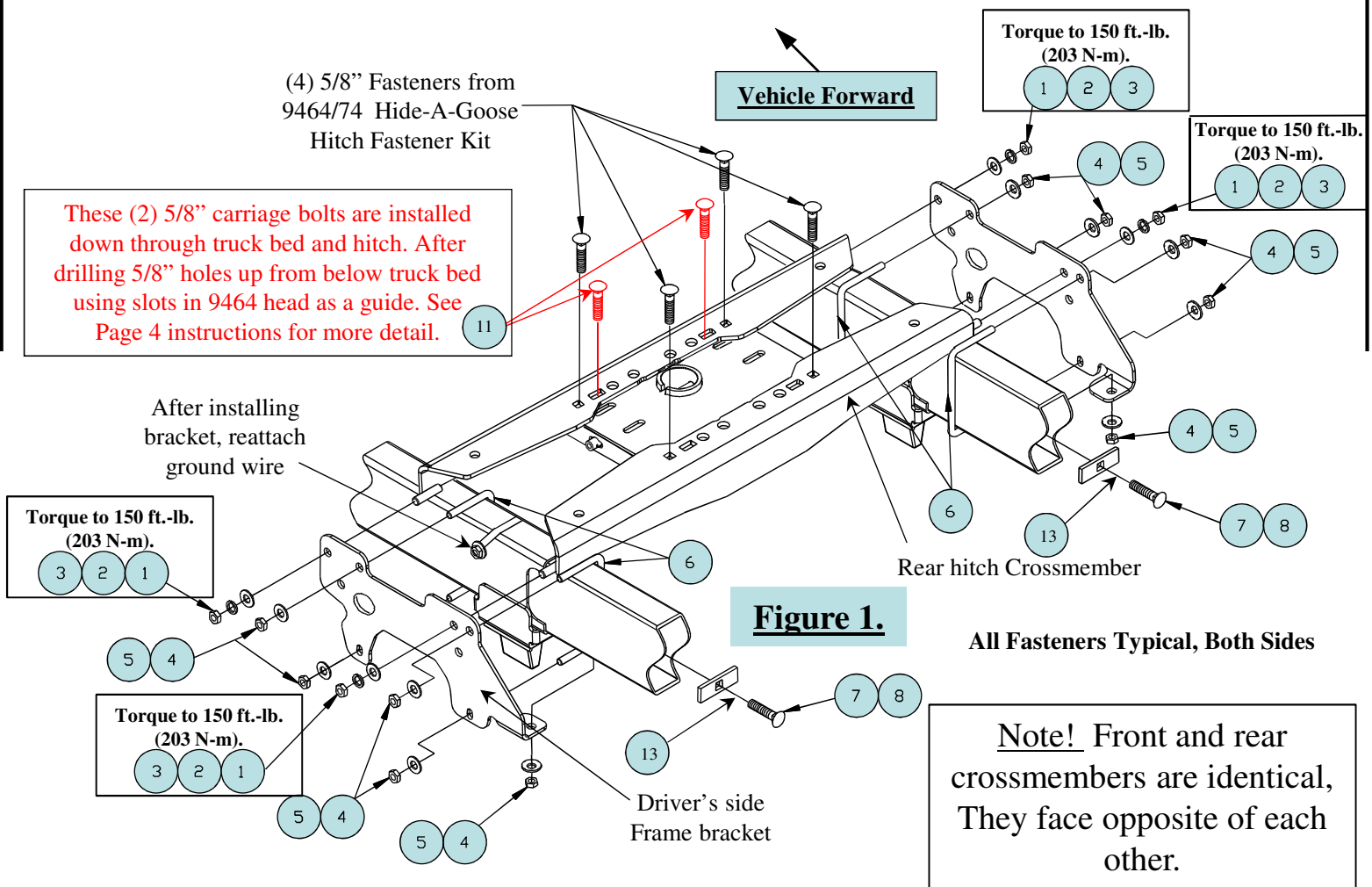

<b>1</b>	Qty. (6)	Hex Nut, 5/8"-11 GR.8, (2) used with <b>11</b> , Fig. 4.	<b>8</b>	Qty. (2)	Block, 1/4" X 1.00 X 3.00
<b>2</b>	Qty. (4)	Lock Washer, 5/8"	<b>9</b>	Qty. (1)	Cable Tie (not shown)
<b>3</b>	Qty. (4)	Flat Washer, 5/8"	<b>10</b>	<del>Qty. (4)</del>	Shims, 1" x 2", not used with this head, see <b>Figure 6 &amp; 9</b> .
<b>4</b>	Qty. (10)	Hex Nut, 1/2"-13	<b>11</b>	Qty. (2)	Carriage Bolt, 5/8-11 GR.8
<b>5</b>	Qty. (10)	Conical Toothed Washer, 1/2"	<b>12</b>	Qty. (2)	Conical toothed Washer, 5/8" (2) used with <b>11</b> , Fig. 4.
<b>6</b>	Qty. (4)	U-Bolt, 1/2"	<b>13</b>	Qty. (2)	1/2" Wire Pulls, (for fish-wiring)
<b>7</b>	Qty. (2)	Carriage Bolt, 1/2-13 GR.5			Another fine "Cequent Performance Products" hitch

# Installation Instructions

## GOOSENECK RAIL MOUNTING KIT

### 9464/9474 HIDE-A-GOOSE INSTALLATION

Part Numbers:  
**4457**

#### NOTES:

- This portion of instructions is for installing the below bed 9464 / 9474 Gooseneck heads only.
- Always make sure the ball is fully locked before towing.
- Keep the ball and ball sleeve well lubricated.
- Periodically re-torque all the hitch fasteners.
- Check ball, hitch coupler, safety chains and other connections for proper operation every time you tow.

#### Warning:

- ❖ The tow vehicle manufacturers recommended towing capacities should UNDER NO CIRCUMSTANCES be exceeded.
- ❖ Check for adequate clearance between the gooseneck trailer and the rear of the cab and the rear of the truck box before installing hitch.
- ❖ All trucks have fuel lines, brake lines and electrical wiring located along the vehicle frame where the rail kit installs. Carefully examine the location of fuel lines, brake lines and electrical wires before installation and be certain not to damage these when positioning the hitch components. Be careful when drilling holes, cutting sheet metal and tightening fasteners as to not limit the integrity of these systems.

#### Hide-A-Goose Only – Drilled hole in bed location (see step 5).

Short Box - 44 inches

Long Box - 46 inches

#### Installation Instructions

1. Lower the vehicle exhaust by removing the retaining clips from the rear (3 to 5) rubber exhaust hangers and then sliding the rubber exhaust hangers from the exhaust hanger hooks. Lower or remove the spare tire to provide clearance for the cross member installation. On 2010 and newer model year vehicles, temporarily remove the ground wire located on the outside of the Driver's side frame rail. It may make it easier to remove the spare tire heat shield also, use 10mm wrench or socket to remove (5) bolts and or nuts holding it in place.
2. Position the cross members from underneath: Place the rear cross member into position by inserting behind driver's side rear tire, in front of shock above spring beneath truck frame as shown in **(Figure 2a)**. Make sure it's facing the right direction. **Note:** the cross members in this kit are the same, but they face different directions as shown in **(Figure 1)**. It may help to locate carriage bolts in outside square holes and put a piece of tape across top of head to top of rail. See note below. Slide the end up over the exhaust and the passenger's side frame rail. Pull rear crossmember back into position as shown in **(Figure 2b)**. Insert front cross member into place at the same location behind the tire in front of the shock beneath the driver's side frame rail, **(Figure 2a)**. It may be necessary to bend the passenger's side drip edge of the truck bed out slightly to allow rail to go in place.

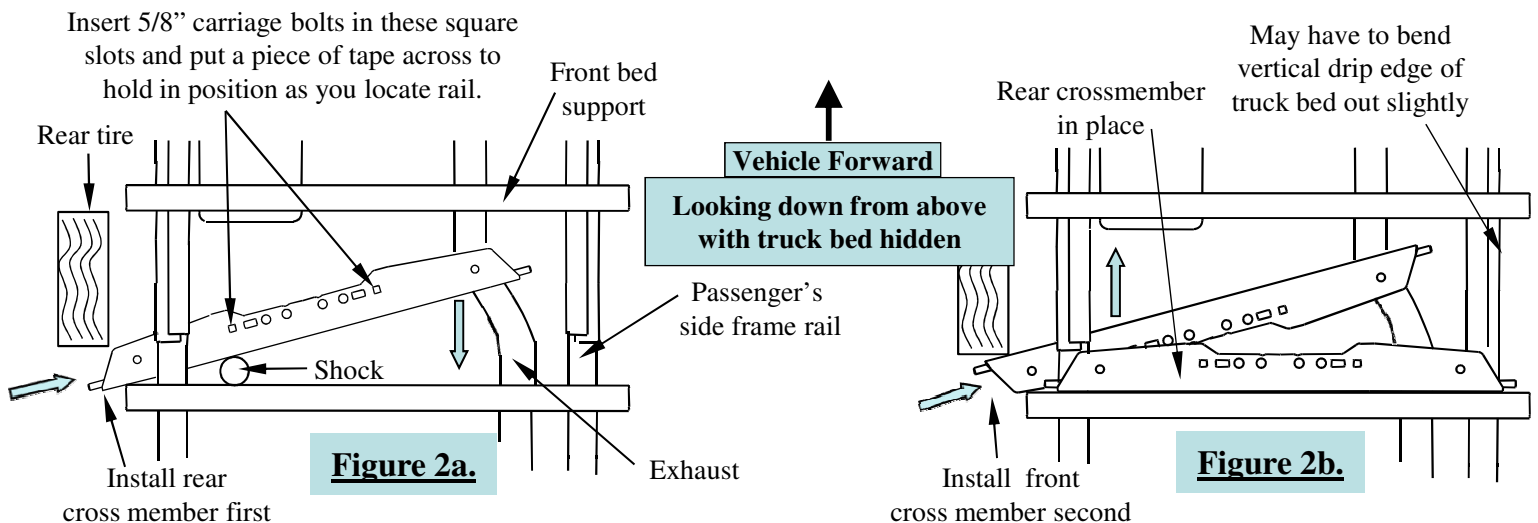

# Installation Instructions

## GOOSENECK RAIL MOUNTING KIT

### 9464/9474 HIDE-A-GOOSE INSTALLATION

Part Numbers:  
**4457**

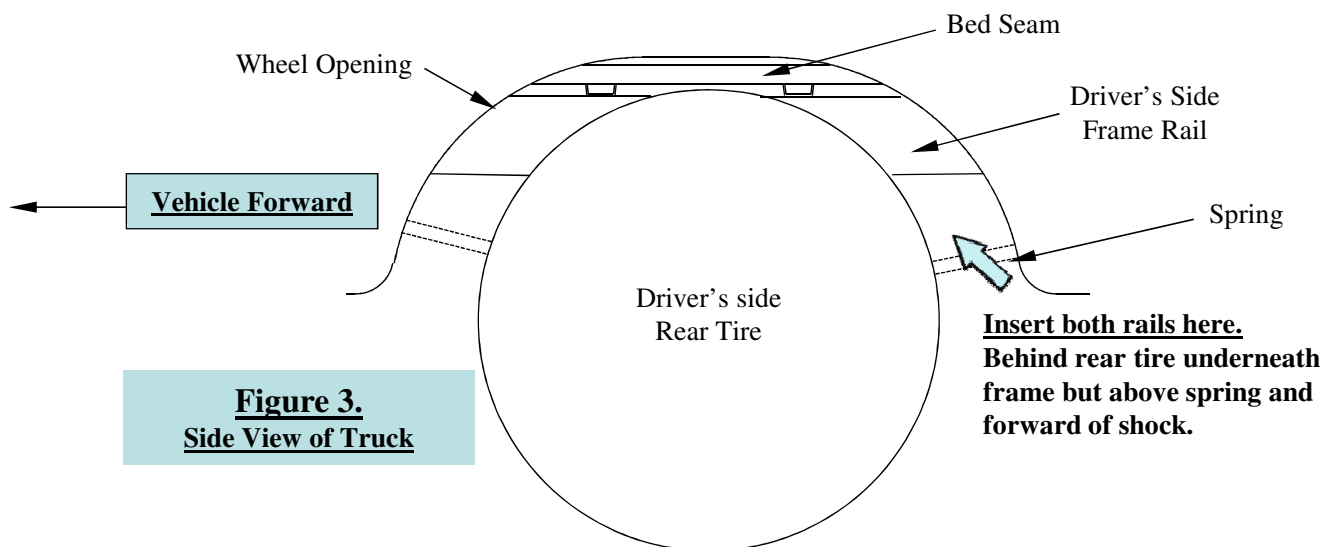

- Line up the mounting holes in the hitch frame brackets with the threaded studs on the ends of the cross members. Loosely attach frame brackets to rails with 5/8 hex nuts, lock washers and flat washers as shown in **Figure 1**. It may help to install the driver's side forward U-bolt first before attaching frame bracket. See **Step 4. below**.
- Use the U-Bolts to attach the frame brackets to the frame as shown in **Figure 1**. It may be necessary to loosen the wire harness from the inside of the driver's side frame in order to position the U-Bolts. The forward driver's side U-Bolt must go between the brake line and the vehicle frame. Loosely fasten the U-Bolts to the frame brackets using the 1/2" nuts and conical toothed washers. Fish wire the 1/2-13 carriage bolts and 1/4 X 1.00 X 3.00 blocks through the holes in the vehicle frame and through the flange on the frame brackets. Loosely install the 1/2" conical toothed washers and hex nuts.
- When installing the 9464/9474 Hide-A-Goose hitch, a hole must be drilled in the bed of the truck. Mark and drill a 1/4" hole **44 inches (6' bed) / 46 inches (8' bed)** from the rear of the bed and centered between the wheel wells. Using a hole saw, enlarge the pilot hole to the final diameter hole size. Refer to the 9464/9474 Hide-A-Goose hitch instruction sheet for hole size.
- Loosely install the 9464/9474 Hide-A-Goose hitch to the cross members. **Note: The ball should be positioned closer to the forward rail than the rear rail. See Figure 1.**
- Use the (2) inner slots on forward side of head to drill 5/8" diameter holes up through truck bed. Make sure that holes go through the truck bed corrugation that is down so that head of conical is recessed below top of bed corrugation.
- Install 5/8" conical bolts from top of truck bed down through holes drilled in previous step and through hitch rail and head slot. Install conical toothed washers and nuts.
- After loosely installing the Hide-A-Goose hitch and 4457 mounting kit, line up the hitch ball sleeve with the opening in the truck bed. Torque the **5/8-11 GR8 nuts to 150 ft.-lb. (203 N-m) on the rails to brackets, 1/2-13 GR5 nuts to 75 ft.-lb. (102 N-m), and 5/8-11 GR8 nuts on the hitch to 212 ft.-lb. (287 N-m)**. Use the following sequence: a) torque frame brackets to the frame of the vehicle, b) torque cross members to the frame brackets, c) torque hitch to cross members. **Note! Different torque for 5/8" nuts depending on location.**
- If the wire harness was loosened to install the driver's side rear U-Bolt and cannot be reattached using the existing fasteners, use the included cable tie to attach the wires to the U-Bolt.8.
- Reinstall the exhaust. Reinstall spare tire heat shield if removed and raise spare tire back in to position. Reattach the ground wire, through the large hole in the Driver's side frame bracket on 2010 and newer model year vehicles. .

# Installation Instructions

## GOOSENECK RAIL MOUNTING KIT

### 9464/9474 HIDE-A-GOOSE INSTALLATION

**Part Numbers:**  
**4457**

**Note! 4457 Rail Kit Only**  
Fasteners for (2) additional attachments are supplied with 4457 rail kit. See Figures 1, 4 & 5.

**Torque all (6) 5/8" head nuts to 212 ft.-lb. (287 N-m).**

**Other fasteners not identified are from 9464 kit, see 9464 instructions.**

**Figure 4.**

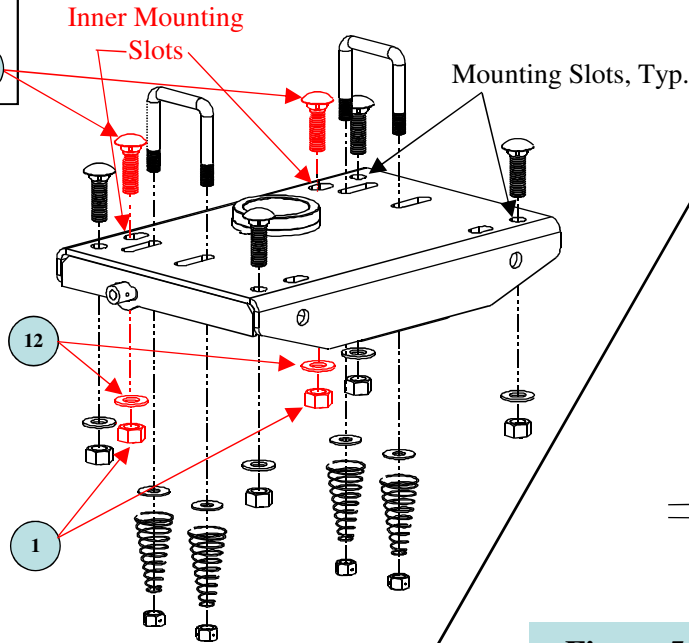

**Looking up at bottom of hitch,** showing location of inner mounting slot fasteners. Typical both sides.

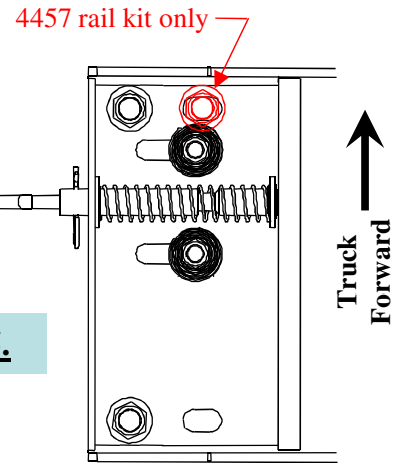

**Figure 5.**

**Driver's side frame bracket shown in proper position**

Grounding stud shown with wire removed to install rail kit. Reattach wire after installation.

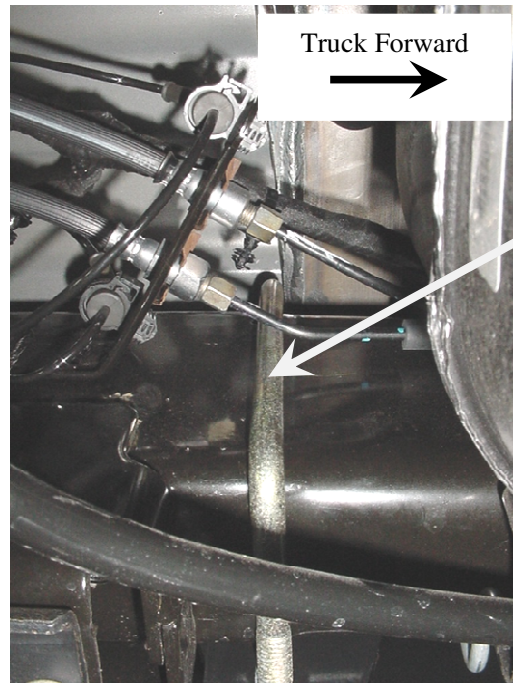
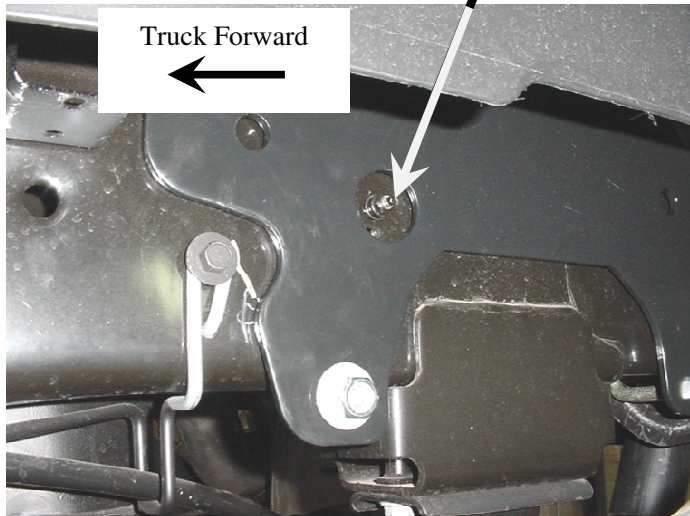

**Inside view of Driver's side frame rail. Showing u-bolt in place between frame and brake lines.**

# Installation Instructions

**Part Numbers:**

## GOOSENECK RAIL MOUNTING KIT

**4457**

Dodge Ram 2500/3500 Heavy Duty  
Short & Long Bed, All Megacabs

### 6300/8339 GOOSENECK HITCH INSTALLATION

If using with 9464 or 9474 under bed gooseneck hitches go to and use Pages 1-4 only.

**Equipment Required:**

**Fastener Kit:** 4457F

**Wrenches:** 3/4, 15/16, 10mm

**Drill Bits:** 1/8", 5/8"

**Other Tools:** Drill, Reciprocating Saw, Tape

**WARNING:** Under no circumstances do we recommend exceeding the towing vehicle manufacturers recommended vehicle towing capacity.

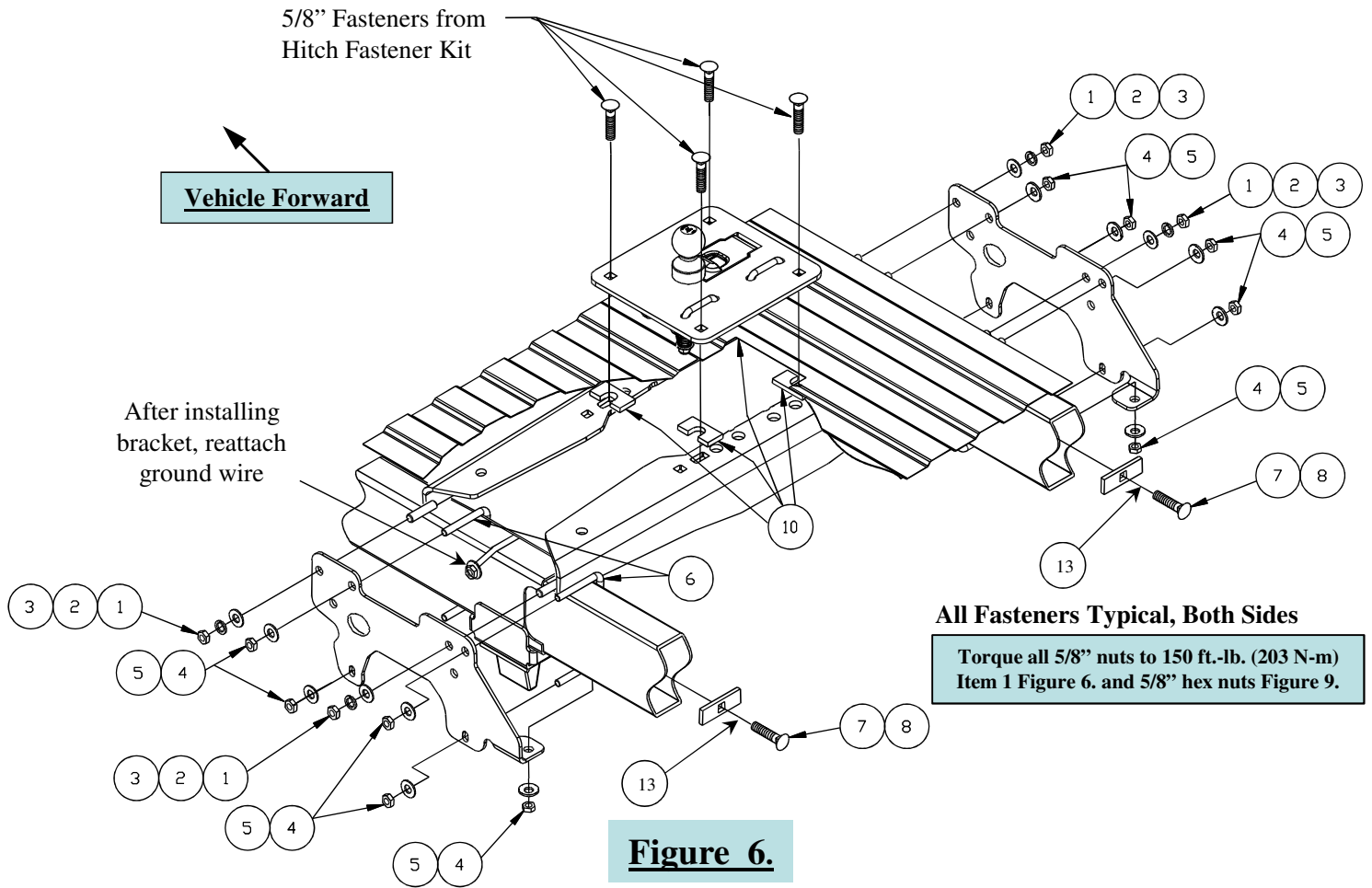

**Figure 6.**

<b>1</b>	Qty. (6)	Hex Nut, 5/8"-11 GR.8, (2) not used with this head.	<b>8</b>	Qty. (2)	Block, 1/4" X 1.00 X 3.00
<b>2</b>	Qty. (4)	Lock Washer, 5/8"	<b>9</b>	Qty. (1)	Cable Tie (not shown)
<b>3</b>	Qty. (4)	Flat Washer, 5/8"	<b>10</b>	Qty. (4)	Shims, 1" x 2"
<b>4</b>	Qty. (10)	Hex Nut, 1/2"-13	<b>11</b>	<del>Qty. (2)</del>	Carriage Bolt, 5/8-11 GR.8 not used see Figure 1. Page 1.
<b>5</b>	Qty. (10)	Conical Toothed Washer, 1/2"	<b>12</b>	<del>Qty. (2)</del>	Conical Toothed Washer, 5/8" not used see Figure 1. Page 1.
<b>6</b>	Qty. (4)	U-Bolt, 1/2"	<b>13</b>	Qty. (2)	1/2" Wire Pulls, (for fish-wiring)
<b>7</b>	Qty. (2)	Carriage Bolt, 1/2-13 GR.5			Another fine "Cequent Performance Products" hitch

# Installation Instructions

Part Numbers:

## GOOSENECK RAIL MOUNTING KIT 6300/8339 GOOSENECK HITCH INSTALLATION

4457

### NOTES:

- This portion of the instruction is for installing the 6300 or 8339 head only.
- Always make sure the ball is fully locked before towing.
- Keep the ball and ball pocket well lubricated.
- Periodically re-torque all the hitch fasteners.
- Check ball, hitch coupler, safety chains and other connections for proper operation every time you tow.

### Warning:

- ❖ The tow vehicle manufacturers recommended towing capacities should **UNDER NO CIRCUMSTANCES** be exceeded.
- ❖ Check for adequate clearance between the gooseneck trailer and the rear of the cab and the rear of the truck box before installing hitch.
- ❖ All trucks have fuel lines, brake lines and electrical wiring located along the vehicle frame where the rail kit installs. Carefully examine the location of fuel lines, brake lines and electrical wires before installation and be certain not to damage these when positioning the hitch components. Be careful when drilling holes, cutting sheet metal and tightening fasteners as to not limit the integrity of these systems.

### Installation Instructions

1. Lower the vehicle exhaust by removing the retaining clips from the rear (4) rubber exhaust hangers and then sliding the rubber exhaust hangers from the exhaust hanger hooks. Lower or remove the spare tire to provide clearance for the cross member installation. On 2010 and newer model year vehicles, temporarily remove the ground wire located on the outside of the Driver's side frame rail. It may make it easier to remove the spare tire heat shield also, use 10mm wrench or socket to remove (5) bolts and or nuts holding it in place.
2. Position the cross members from underneath: Place the rear cross member into position by inserting behind driver's side rear tire, in front of shock above spring beneath truck frame as shown in **(Figure 2a)**. Make sure it's facing the right direction. Note: the cross members in this kit are the same, but they face different directions as shown in **(Figures 1 & 6.)** It may help to locate carriage bolts in square slots and put a piece of tape across top of head to top of rail. See note below. Slide the end up over the exhaust and the passenger's side frame rail. Pull rear crossmember back into position as shown in **(Figure 2b)**. Insert front cross member into place at the same location behind the tire in front of the shock beneath the driver's side frame rail, **(Figure 2a)**. It may be necessary to bend the passenger's side drip edge of the truck bed out slightly to allow rail to go in place.

Insert 5/8" carriage bolts in these square slots and put a piece of tape across to hold in position as you locate rail.

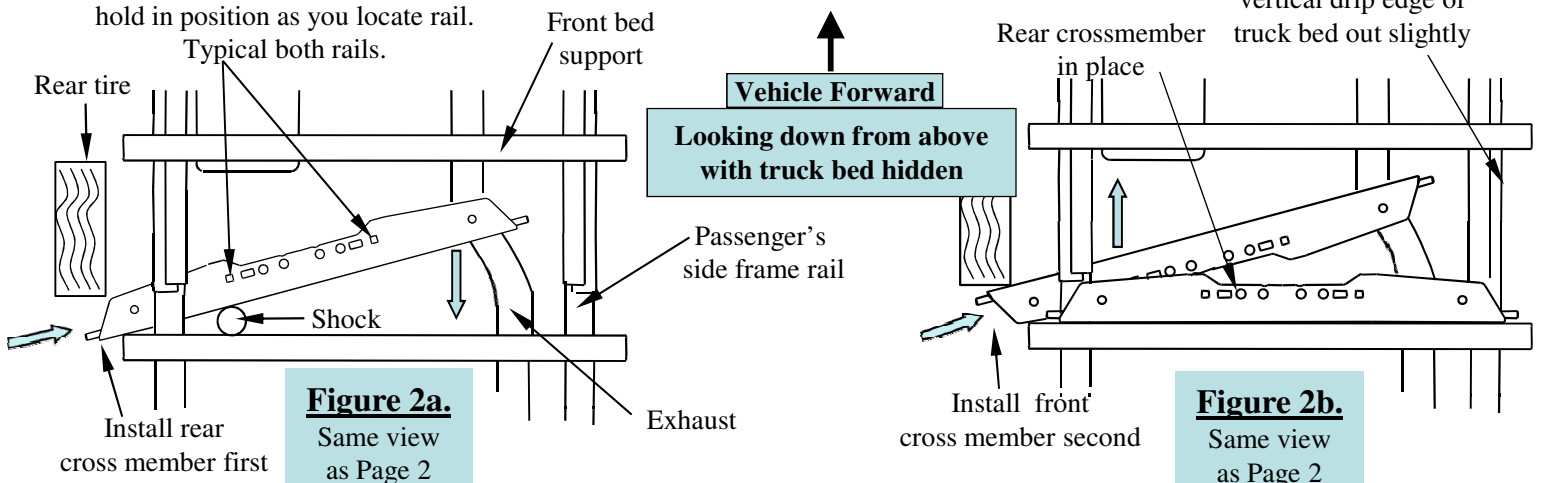

# Installation Instructions

## GOOSENECK RAIL MOUNTING KIT 6300/8339 GOOSENECK HITCH INSTALLATION

Part Numbers:

**4457**

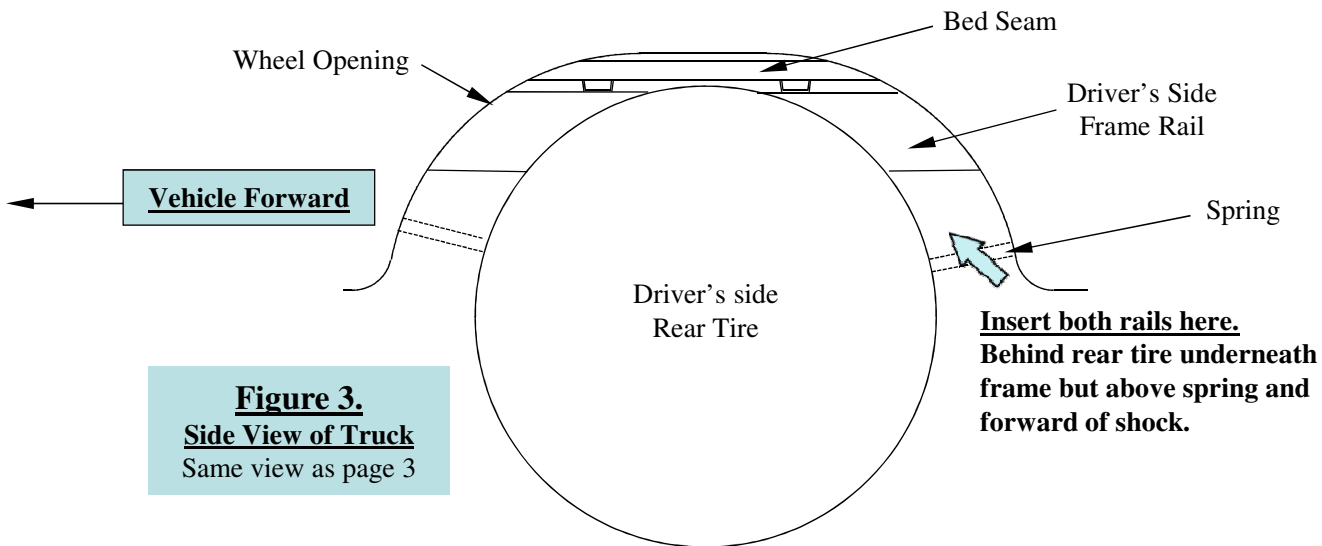

- Line up the mounting holes in the hitch frame brackets with the threaded studs on the ends of the cross members. Loosely attach frame brackets to rails with 5/8 hex nuts, lock washers and flat washers as shown in **Figure 1**. It may help to install the driver's side forward U-bolt first before attaching frame bracket. See **Step 4**. below.
- Use the U-Bolts to attach the frame brackets to the frame as shown in **Figure 1**. It may be necessary to loosen the wire harness from the inside of the driver's side frame in order to position the U-Bolts. The forward driver's side U-Bolt must go between the brake line and the vehicle frame. Loosely fasten the U-Bolts to the frame brackets using the 1/2" nuts and conical toothed washers. Fish wire the 1/2-13 carriage bolts and 1/4 X 1.00 X 3.00 blocks through the holes in the vehicle frame and through the flange on the frame brackets. Loosely install the 1/2" conical toothed washers and hex nuts.
- With the cross members and side brackets installed, torque the 5/8-11 GR8 nuts that attach the forward cross member to the brackets to 150 ft.-lb (203 N-m). Torque the 1/2" fasteners and U-Bolt fasteners that attach the side brackets to the frame to 75 lb.-ft. (102 N-m). The rearward cross member should be left loose until **Step 16**.
- For 6300 & 8339 use the outer edges of the long square slots in the forward cross member as a template to drill 5/8" diameter holes through the truck bed as shown in **Figure 7**. below. Not all holes can be drilled from under the vehicle, but should be done later from inside the bed.
- Align the holes on the template (provided with the gooseneck hitch) with the holes previously drilled through the bed. Be sure that the template is properly oriented toward the front of the vehicle. Center punch the holes that will be used to cut the opening in the bed (see **Figure 8**. next page.). If the vehicle is equipped with a bed liner, a section of the bed liner must be cut away so that the gooseneck platform can contact the bed corrugations.
- Drill 1/4" pilot holes (size will depend on width of blade in saber saw).
- Cut out the truck bed and file edges as needed.

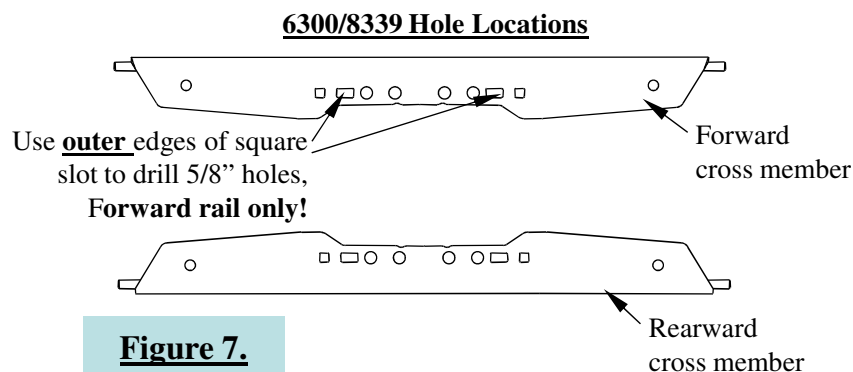

**Figure 7.**

# Installation Instructions

## GOOSENECK RAIL MOUNTING KIT

### 6300/8339 GOOSENECK HITCH INSTALLATION

**Part Numbers:**

**4457**

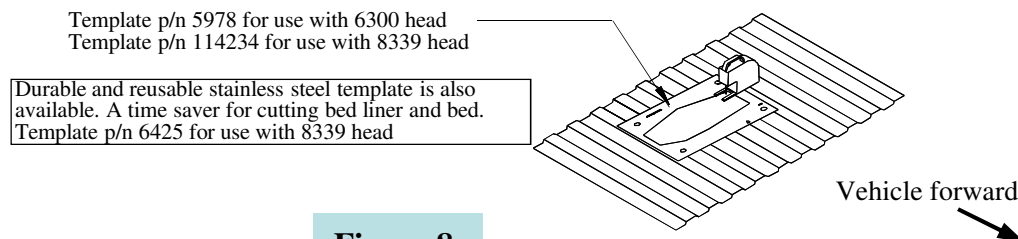

**Figure 8.**

**WARNING** The fuel tank and/or other vehicle components may be located below some of the holes. A wood or metal shield must be placed between the frame and the fuel tank or other critical components to prevent damage when the drill breaks through the bed.

10. Install the hitch into the opening.
11. Use the hitch as a guide to drill the 5/8" diameter holes for the rearward cross member and the U-Bolts holes.

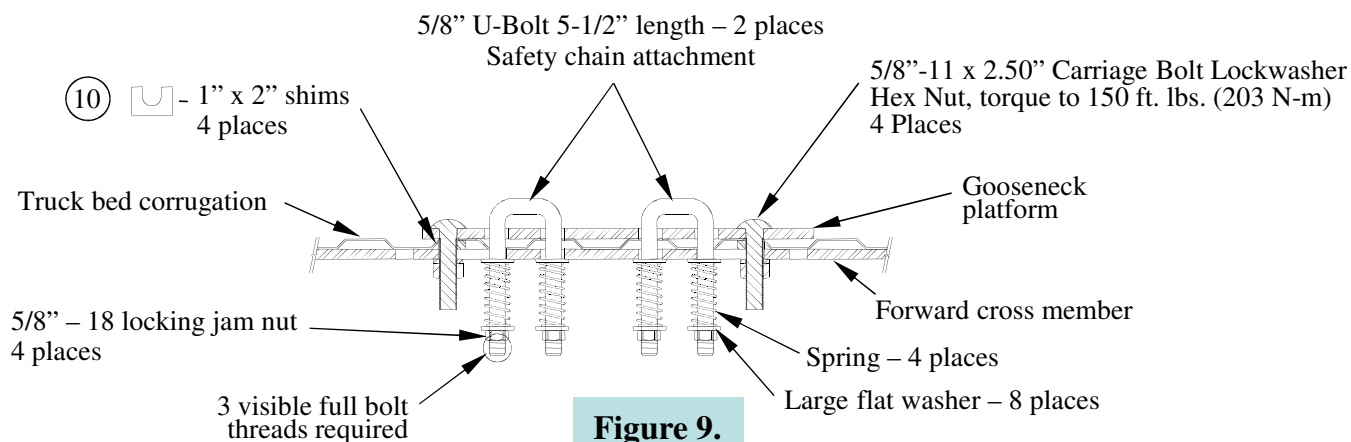

**Figure 9.**

12. Before installing the 5/8" carriage bolts through the hitch, the U-Block shims must be placed between the hitch and the bed and between the cross members and the bottom of the bed, (see Figure 9.). These shims are necessary to prevent the bed corrugations from collapsing when the bolts are tightened.
13. Align the rearward cross member with the 5/8" diameter drilled holes.
14. Install the 5/8 X 2.50 GR5 carriage bolts through the hitch, shims and cross members. Secure with lock washers and nuts. Torque nuts to 150 ft.-lb. (203 N-m).
15. Install the (2) U-bolts through the hitch. From under the vehicle install the large flat washer over the U-Bolt followed by a spring, another large flat washer and secure with a thin 5/8" jam nut. Repeat for the other legs of the U-Bolts. The 5/8" jam nuts are tightened until (3) threads are visible past the bottom of the jam nut.
16. Torque the 5/8-11 GR8 nuts connecting the rearward cross member to the brackets to 150 ft.-lb. (203 N-m).
17. If the wire harness was loosened to install the rear driver's side frame bracket u-bolt and cannot be reattached using the existing fasteners, use the cable tie to attach the wires to the u-bolt.
18. Reinstall the exhaust, and reinstall the spare tire shield if removed. Raise the spare tire back in to position. Reattach the ground wire, through the large hole in the Driver's side frame bracket on 2010 and newer model year vehicles.