

INSTALLATION INSTRUCTIONS

VEHICLE	CHEVROLET/GMC FULL SIZE PICKUPS (ALL MODELS)	HITCH NO.	41524
---------	---	-----------	-------

EQUIPMENT REQUIRED:

WIRING ACCESS LOCATION: PU3

DRILL BITS: NONE

HITCH REQUIRES 5/8" PIN AND CLIP IF STABILIZING PIN IS NOT INSTALLED.

WRENCHES: (TIGHTEN ALL FASTENERS WITH TORQUE WRENCH) 7/8, 13mm, 18mm, 19mm

DO NOT EXCEED LOWER OF
TOWING VEHICLE MFR'S RATINGS OR

HITCH TYPE ▼	MAX GROSS TLR WT(LB)	MAX TONGUE WT(LB)
WEIGHT DISTRIBUTING	10,000	1000
WEIGHT CARRYING BALL MOUNT	6000	600

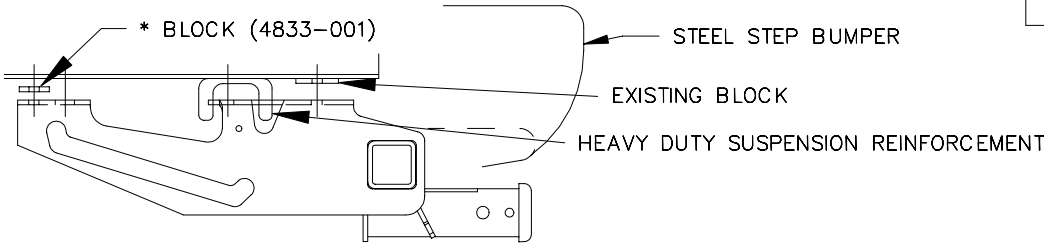

HITCH SHOWN IN PROPER
POSITION FOR 6 FT BEDS
WITH OPTIONAL HEAVY
DUTY SUSPENSION.

WARNING:

CHECK CLEARANCE BETWEEN
BRAKE LINE, AXLE, TAILPIPE
AND STOWED SPARE TIRE.

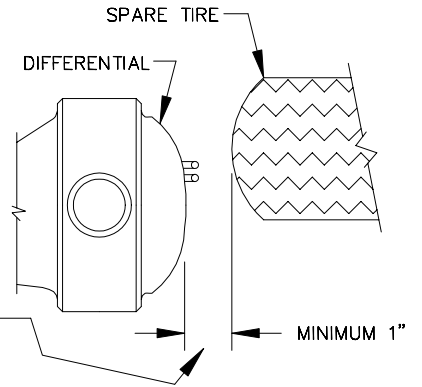

FIGURE 3

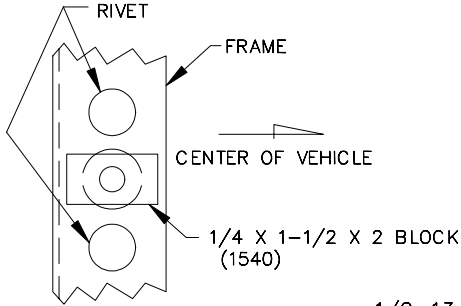

FIGURE 1

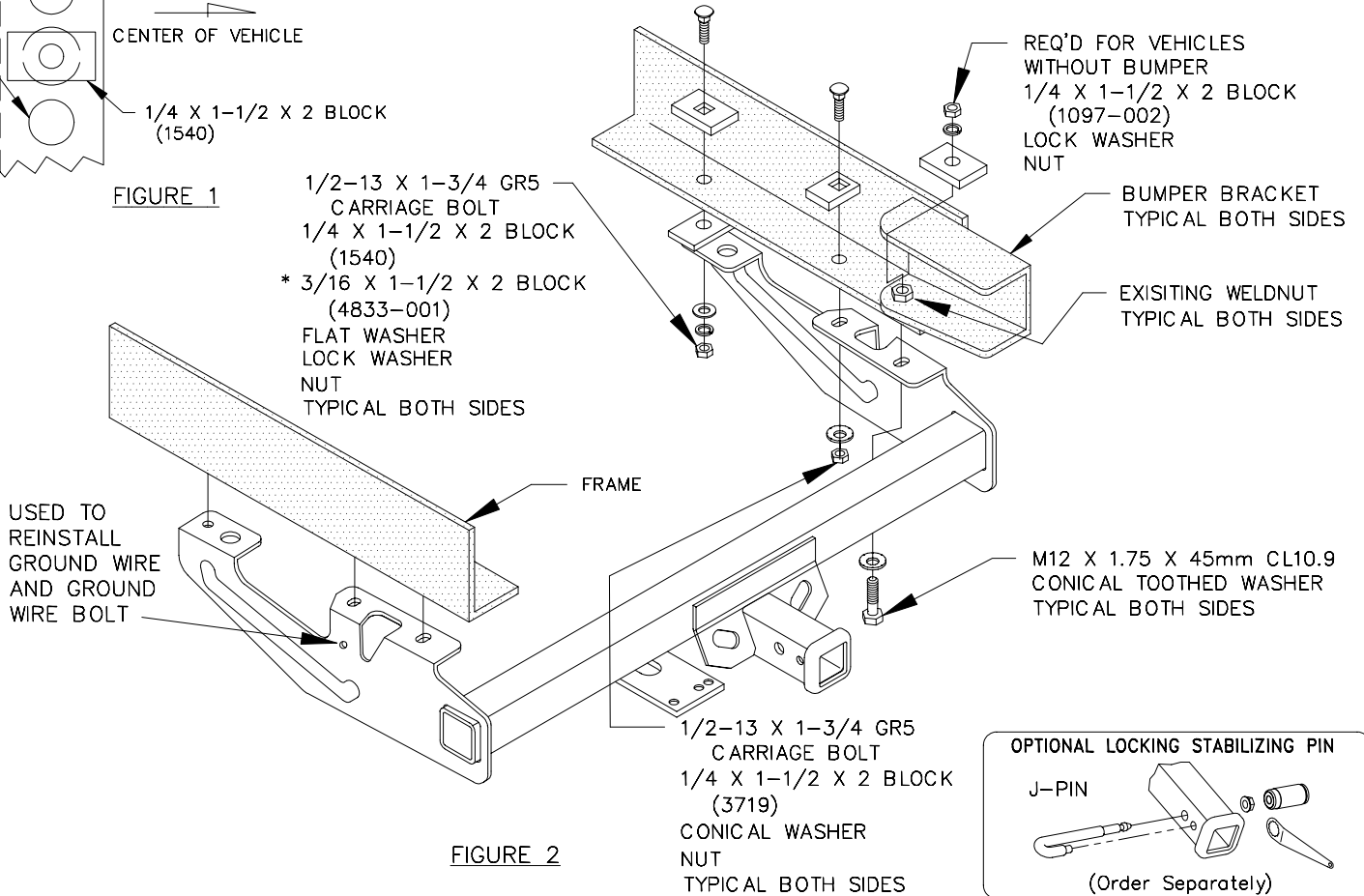
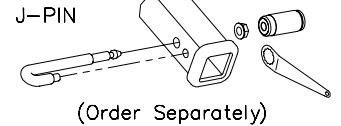

FIGURE 2

OPTIONAL LOCKING STABILIZING PIN



* ONLY USED ON 6 FT BEDS WITH HEAVY DUTY SUSPENSION.

NOTE: ON VEHICLES WITHOUT FACTORY BUMPER, IT WILL BE NECESSARY TO RELOCATE LICENSE PLATE MOUNTING BRACKET.

1. LOWER VEHICLE SPARE TIRE IF PRESENT.
2. REMOVE AND DISCARD M12 HEX BOLTS FROM END OF EACH FRAME RAIL IF PRESENT.
3. REMOVE GROUND WIRE AND GROUND WIRE BOLT, IF PRESENT, ON DRIVER'S SIDE FRAME RAIL.
4. LIFT RECEIVER INTO POSITION, LOCATING SLOTS IN RECEIVER OVER WELDNUTS IN VEHICLE FRAME.
NOTE: FOR VEHICLES W/O BUMPER, LOCATE SLOTS IN RECEIVER OVER FORE/AFT SLOT NEAR END OF FRAME.
5. INSTALL M12 HEX BOLT (SUPPLIED) AND TOOTHED WASHER THROUGH RECEIVER INTO WELDNUT IN VEHICLE FRAME.
NOTE: SEE ILLUSTRATION FOR PLACEMENT OF FASTENERS ON VEHICLES W/O BUMPER.
6. INSTALL REMAINING FASTENERS AS SHOWN IN FIGURE 2.
7. REINSTALL GROUND WIRE AND GROUND WIRE BOLT TO HOLE IN SIDE OF SIDE BRACKET.

NOTE: ON 6' BED MODELS, 1/4 X 1-1/2 X 2 BLOCK (1540) LOCATED AT FORWARD-MOST ATTACHMENT ON DRIVER'S SIDE MAY BE ORIENTED AS SHOWN IN FIGURE 1, IF NECESSARY, TO INSURE CLEARANCE OF RIVETS. BLOCK MUST SIT FLAT ON FRAME.

TIGHTEN M12 CL10.9 FASTENERS TO 75 LB.-FT.
TIGHTEN 1/2-13 GR5 FASTENERS TO 75 LB.-FT.

8. RAISE SPARE TIRE.

WARNING: CHECK CLEARANCE BETWEEN BRAKE LINE, AXLE, TAILPIPE, AND STOWED SPARE TIRE. MINIMUM RECOMMENDED CLEARANCE IS 1". IF CLEARANCE IS INSUFFICIENT SPARE TIRE MUST BE STOWED ELSEWHERE.

APPROX WEIGHT (LB.)	FASTENER KIT
48	1130-969

NOTE: Check hitch frequently, making sure all fasteners and ball are properly tightened. If hitch is removed, plug all holes in trunk pan or other body panels to prevent entry of water and exhaust fumes. A hitch or ball which has been damaged should be removed and replaced. Observe safety precautions when working beneath a vehicle and wear eye protection. Follow car maker's specs for maximum trailer weight and tongue weight. Do not cut access or attachment holes with a torch.