

Installation Instructions

Dodge Ram Chassis Cab 3500/4500/5500

Chevrolet Silverado 3500 Cab & Chassis*

GMC Sierra 3500 Cab & Chassis*

Part Numbers:
41936

*-Includes Classic and New Body Styles

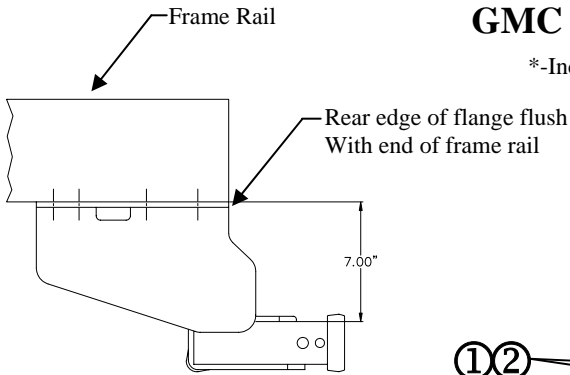

Hitch Shown In Proper Position

Equipment Required:

Fastener Kit: 41936F

Wrenches: 3/4"

Drill Bits: 17/32"

Chisel, Grinder, Clamps

Center Punch

Rivet to be Removed this Location – Dodge Only

Fasteners Typical Both Sides

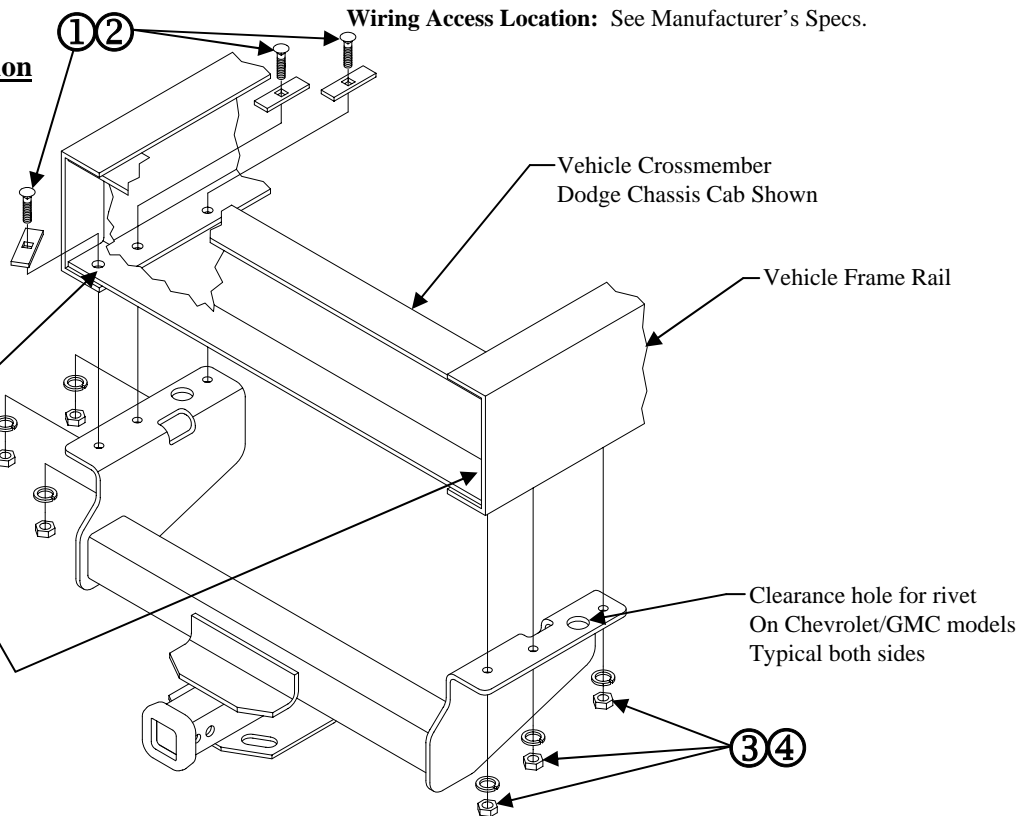

**Do Not Exceed Lower of Towing Vehicle
Manufacturer's Rating or**

Hitch type	Max Gross Trailer WT (LB)	Max Tongue WT (LB)
Weight Distributing	Do Not Use With	Spring Bars
Weight Carrying Ball Mount	12,000 (5448 Kg)	1,200 (545 Kg)

Wiring Access Location: See Manufacturer's Specs.

①	Qty. (6)	Carriage Bolt 1/2-13 x 1.75 GR8	③	Qty. (6)	Lock Washer 1/2"
②	Qty. (6)	Spacer Block 1/4" x 1" x 3"	④	Qty. (6)	Hex Nut – 1/2-13 GR8

Dodge Chassis Cab Models:

1. Remove rearmost rivet on bottom of frame rail, each side. (Rivet location will be enlarged in step 3).
2. Raise hitch into position, placing rear edges of horizontal flanges flush with end of frame rails and clamp to frame rail.
3. Using hitch as a template, drill 3 holes each side as shown, using extreme caution when drilling near fuel filler lines on driver's side. (Note: 1" diameter hole is a clearance hole for Chevrolet/GMC vehicles only and therefore not used for drilling).
4. Install fasteners as shown.

Chevrolet/GMC Cab & Chassis Models:

1. Raise hitch into position, aligning 1" diameter hole with rivet on bottom surface of frame rail, each side and clamp in place.
2. Using hitch as a template, drill 3 holes each side as shown.
3. Install fasteners as shown.

Tighten all 1/2-13 GR8 fasteners with torque wrench to 110 Lb.-Ft. (149 N*M)

Note: check hitch frequently, making sure all fasteners and ball are properly tightened. If hitch is removed, plug all holes in trunk pan or other body panels to prevent entry of water and exhaust fumes. A hitch or ball which has been damaged should be removed and replaced. Observe safety precautions when working beneath a vehicle and wear eye protection. Do not cut access or attachment holes with a torch.