

Installation Instructions

Acura RDX

Part Numbers:

75563

87449

44584

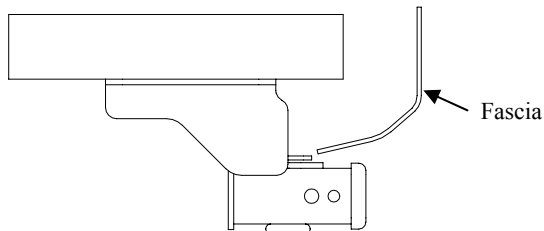

**Do Not Exceed Lower of Towing Vehicle
Manufacturer's Rating or**

Hitch type	Max Gross Trailer WT (LB)	Max Tongue WT (LB)
Weight Distributing	Not For Use With Spring Bars	
Weight Carrying Ball Mount	4000 (1816 Kg)	400 (182 Kg)

Hitch Shown In Proper Position

Equipment Required:

Fastener Kit: 75563F

Wrenches: 3/4, 19mm

Drill Bits: None

Wiring Access Location: SUV1, SUV2

**Note: Fasteners typical
both sides**

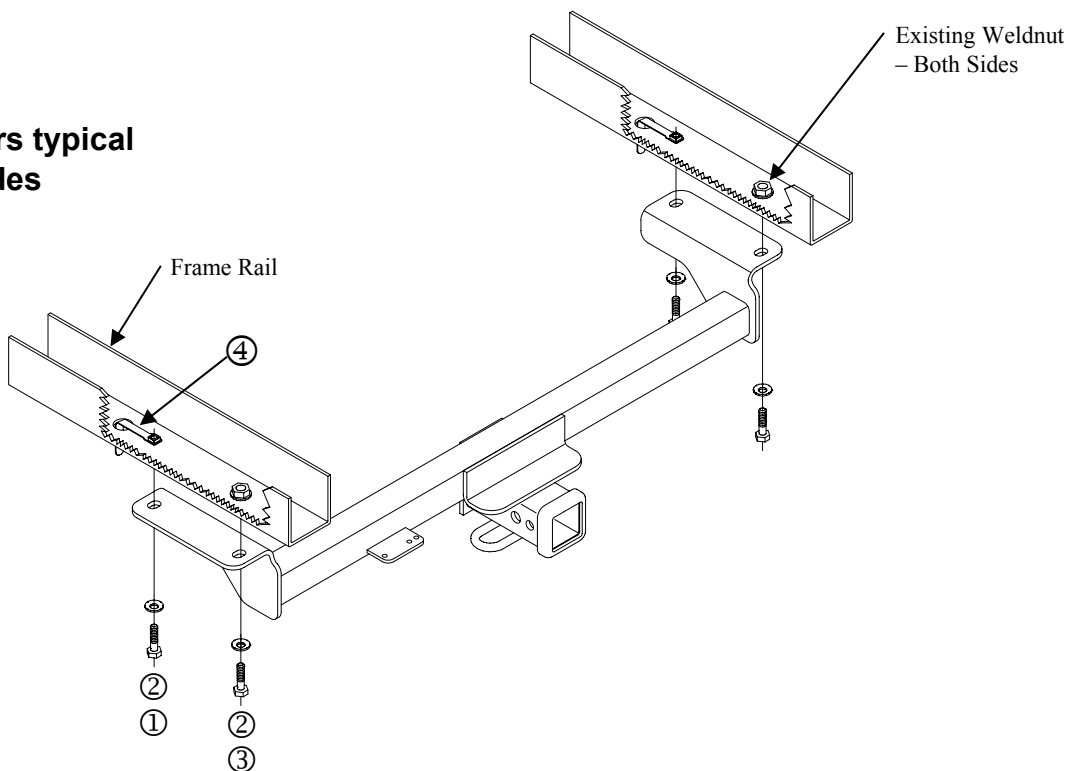

①	Qty. (2)	Hex bolt 1/2-13 x 1.75 GR5	③	Qty. (2)	M12 X 1.25 X 40mm CL 10.9
②	Qty. (4)	1/2 Conical Toothed Washer	④	Qty. (2)	1/2 Handle Nut

1. Raise hitch into position and align the slots of the receiver with the weldnuts in the frame rail.
2. Install the M12 X 1.25 X 40mm bolts and conical toothed washer through the hitch and into the weldnuts.
3. Insert the handle nuts through the large hole in the vehicle frame rail as shown above.
4. Install the 1/2-13 X 1.75 bolts and conical toothed washers.

Tighten all M12 X 1.25 CL 10.9 fasteners with torque wrench to 115 Lb.-Ft. (156 N*M)

Tighten all 1/2-13 GR 5 fasteners with torque wrench to 75 Lb.-Ft. (102 N*M)

Note: check hitch frequently, making sure all fasteners and ball are properly tightened. If hitch is removed, plug all holes in trunk pan or other body panels to prevent entry of water and exhaust fumes. A hitch or ball which has been damaged should be removed and replaced. Observe safety precautions when working beneath a vehicle and wear eye protection. Do not cut access or attachment holes with a torch.