

## 3932 SERIES

### ULTRA THIN SURFACE MOUNT LED HEAD

#### TECHNICAL SPECIFICATIONS

|                          |                             |
|--------------------------|-----------------------------|
| INPUT VOLTAGE .....      | 12.8 Vdc (10 to 16V)        |
| INPUT CURRENT .....      | 0.5 Amps average            |
|                          | 1 Amps peak                 |
|                          | (varies with flash pattern) |
| LED ELEMENTS .....       | 18                          |
| FLASH PATTERNS .....     | 16                          |
| MAX NUMBER OF            |                             |
| SYNCHRONIZED HEADS ..... | 64                          |

#### DIMENSIONS

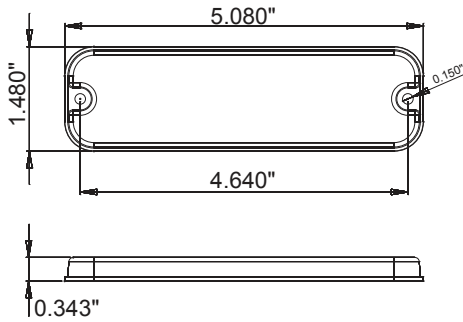

#### HOLE TEMPLATE

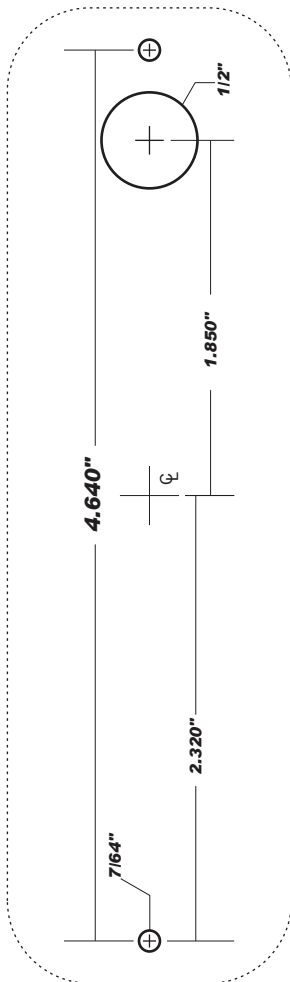

FOR REFERENCE ONLY  
MEASURE BEFORE DRILLING

#### ALTERNATING/SIMULTANEOUS MODE

#### READ THESE INSTRUCTIONS BEFORE INSTALLING THE UNITS.

By default, all units will flash at the same time (SIMULTANEOUS MODE).

To make one or more of the LED heads ALTERNATE with the rest, do this procedure to only those heads you want to alternate.

- 1) Twist BLUE and RED together and touch to +12V. Touch BLACK to Ground. The LED head will flash once and then pause for 5 seconds. After 5 seconds the unit will flash once more, then run the DOUBLE flash pattern.
- 2) Disconnect from power. The unit is now programmed for ALTERNATING MODE. The unit will remember this setting even when removed from power. Follow the rest of the installation procedure below.

If you wish to switch a head back to SIMULTANEOUS mode, repeat the above procedure. After the 5 second programming time, the unit will flash to indicate its mode.

- 1 FLASH = ALTERNATING MODE
- 2 FLASHES = SIMULTANEOUS MODE

#### INSTALLING THE 3932

- (1) Use the HOLE TEMPLATE to mark the hole locations for the two mounting screws and the wires. Drill 7/64" pilot holes for the mounting screws and a 1/2" hole for the wires.
- (2) Make Electrical Connections: *Wiring diagrams on back*

**THE WIRE CONNECTIONS MUST BE SEALED IF USED IN A WET LOCATION. WATER MAY TRAVEL UP AN UNSEALED WIRE AND CAUSE CORROSION PROBLEMS.**

#### USE AT LEAST 18AWG WIRE FOR POWER CONNECTIONS

RED Wire: Connect to +12V through an ON/OFF switch. The use of a fuse located close to the voltage source is recommended.  
 BLACK Wire: Connect to - GROUND vehicle chassis.  
 BLUE: Flash pattern SYNC and SELECTION wire.  
 If you wish to have all the LED heads synchronize their flash timings and patterns with each other then all the BLUE wires must be connected together. (64 Heads Maximum)  
 The BLUE wire is also used to select the flash pattern. Touch the BLUE wire to +V to select the next pattern in the FLASH PATTERN LIST. The BLUE wire can also be run to a momentary push-button located on the dashboard to allow the flash pattern to be changed when desired.

**Note: Do not connect the BLUE wire to - Ground as it will disrupt the flash pattern sync signal.**

The 3932 will also sync with other Nova products.

- (3) Mount the 3932 with the two #6x1/2" stainless steel screws (supplied). *NOTE: The 3932 should not be mounted to an extremely curved surface.*

## WIRING DIAGRAM 1

### BASIC WIRING WITH SIMPLE ON/OFF SWITCH

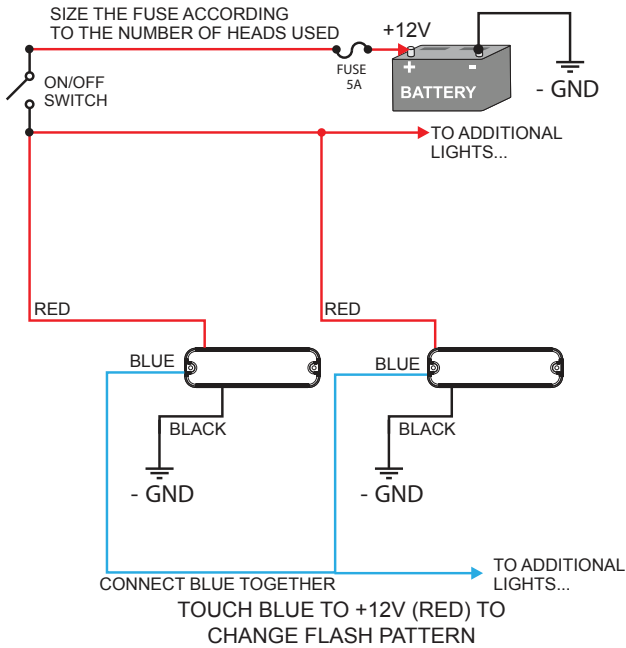

## WIRING DIAGRAM 2

### ON/OFF AND FLASH PATTERN SELECTION

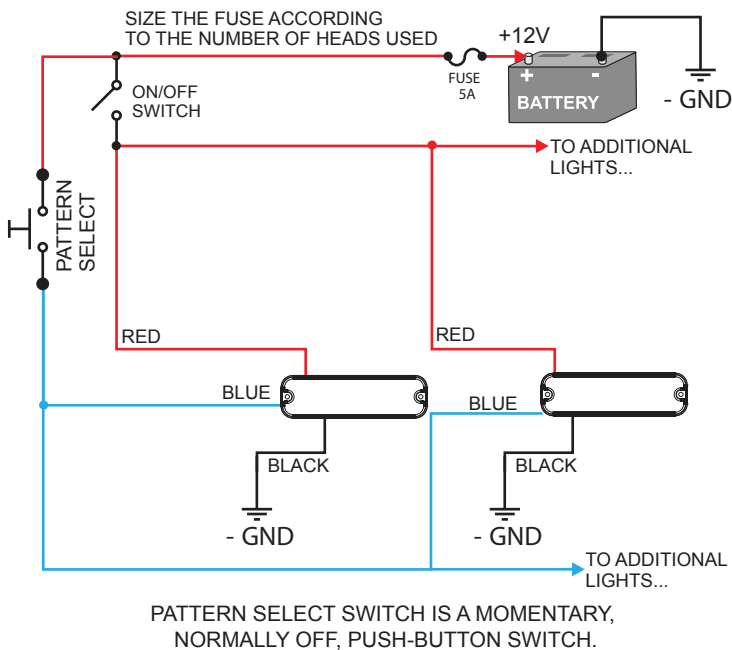

## CONNECTION TO FLASHER

The 3932 can be driven by any lamp flasher or LED flasher that is made to drive +12 Volt lamps or LED heads.

**SET THE 3932 TO PATTERN 8  
STEADY ON  
WHEN USING WITH FLASHER**

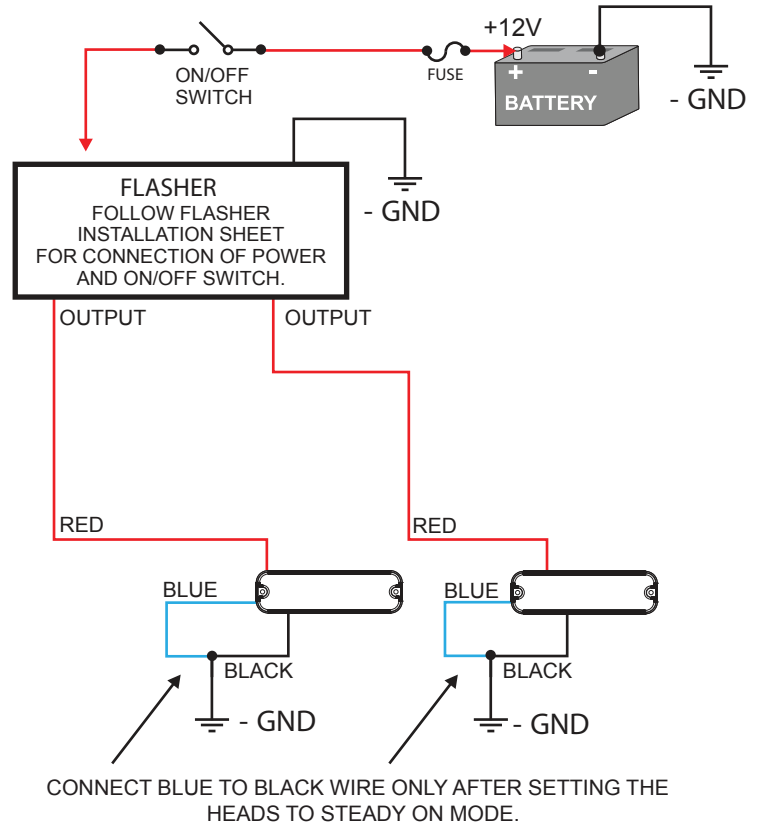

## SEALING WIRE CONNECTIONS

### ELECTRICAL TAPE WILL NOT SEAL A CONNECTION

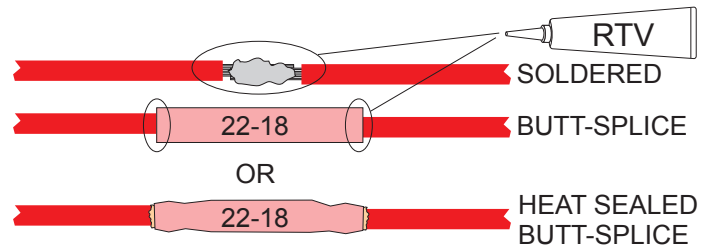

## FLASH PATTERN LIST

### POWER-UP RESET:

After installing the system it is best to do a POWER-UP RESET the first time to ensure that all heads are in sync. Touch **BLUE** wires to +V (**RED** wire) while applying power. Release **BLUE** wires. All heads will reset to Pattern #2. If you have installed a pattern select pushbutton, press and hold pattern select while turning power switch ON.

To select a flash pattern, touch **BLUE** to +V or press pattern select switch to increment the flash pattern. The heads will remember the selected pattern even if power is removed.

| STANDARD PATTERNS |                         |            |  |
|-------------------|-------------------------|------------|--|
| #                 | Pattern:                | Frequency: | Description:                           |
| 1                 | Quad Flash              | 1.25 Hz    | 75 Quad Flashes Per Minute.            |
| 2                 | Double Flash            | 1.25 Hz    | 75 Double Flashes Per Minute.          |
| 3                 | Triple Flash            | 1.53 Hz    | 92.3 Triple Flashes Per Minute.        |
| 4                 | DeciBlast               | 1.42 Hz    | 85.5 Deci Flashes Per Minute.          |
| 5                 | Single Flash            | 1.25 Hz    | 75 Single Flashes Per Minute.          |
| 6                 | Mega Flash              | 1.90 Hz    | 114 Single Flashes Per Minute.         |
| 7                 | Triple+Burst            | 1.37 Hz    | 82.5 Triple+Burst Flashes Per Minute.  |
| 8                 | Steady On               |            | Steady On.                             |
| CYCLE PATTERNS    |                         |            |  |
| 9                 | Cycle All               |            | Cycle through patterns 1 to 7.         |
| 10                | Double-Triple+Burst     |            | 2 Double, 2 Triple+Burst cycle.        |
| 11                | Cycle Classic           |            | 1 Double, 1 Quad, 2 Mega cycle.        |
| 12                | Quad-Mega               |            | 3 Quad, 4 Mega cycle.                  |
| 13                | Single-Quad             |            | 2 Single, 2 Quad cycle.                |
| 14                | DeciBlast-Quad          |            | 2 DeciBlast, 2 Quad cycle.             |
| 15                | Single-Triple-DeciBlast |            | 2 Single, 2 Triple, 2 DeciBlast cycle. |
| 16                | Mega-Triple+Burst       |            | 1 Mega, 1 Triple+Burst cycle.          |