

BEACONS | MINIBARS | LIGHTBARS | DIRECTIONALS | WORKLAMPS | UTILITY BARS | INTERIOR LIGHTING | CAMERA SYSTEMS

BACK-UP ALARMS

40 SERIES Grommet Mount

The 40 series back-up alarms utilize a standard 4.5" rear-lighting grommet for mounting directly into the vehicle body. Vehicle down time is reduced since the alarm can be fitted or replaced quickly and easily without the use of tools; there are no holes to drill and no bolts to tighten. Not only is the 'in-body' mounting method easier to install, it also ensures the warning signal is projected where it is needed, directly into the hazard zone at the rear of the vehicle. Three models are available, 97 and 102dB(A) fixed decibel versions as well as an 82-102dB(A) Smart Alarm® unit.

ECCO's Smart Alarm models measure ambient noise and adjust their sound level, creating a volume that is safe without being annoying or contributing to noise pollution. Smart Alarms eliminate the need for constant manual adjustment and help prevent intentional alarm disconnection.

Models

PART NO.	VOLTAGE	dB(A)	AMPS	APPROVALS
SA955 	12-24	82-102	0.4	CE, R10
435	12-24	102	0.3	SAE Type F, CE, R10
415	12-24	97	0.2	SAE Type C, CE, R10

Features and Benefits

- Grommet mount reduces installation time, requiring no tools
- Directs warning to rear of vehicle
- For use with standard 4.5" rear lighting grommet (order separately)
- Temperature Range: -40°F to +185°F (-40°C to +85°C)
- 2 Year Warranty

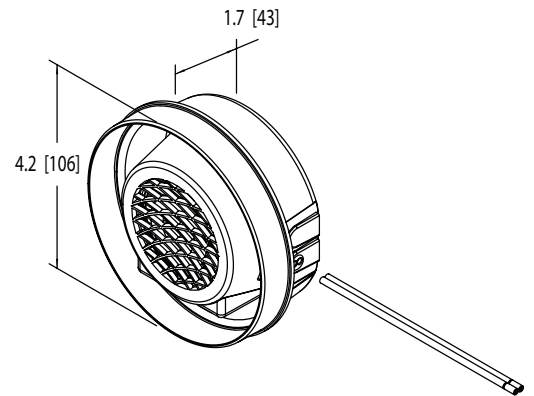

Alarm Specifications

Connection: 16 AWG blunt cut wires
Housing: Fiberglass reinforced nylon
Mounting: 4.5" standard rear lighting grommet

Parts & Accessories

- Mounting Grommet: R2140GR

