

BEACONS | LIGHTBARS | DIRECTIONALS | WORKLAMPS | UTILITY BARS | INTERIOR LIGHTING | BACK-UP ALARMS | CAMERA SYSTEMS

MINIBARS

5587 SERIES SAE Class I 15" LED

Reflex™ LED minibars provide a compact yet powerful warning solution that offers the flexibility of either permanent, vacuum-magnet or magnet mounting. Featuring 12-24 VDC operation, the Reflex™ uses high intensity LEDs and reflective technology to maximize light output. Users can select from 18 flash patterns, either via trigger wire on permanent mount models or cigarette plug switch on magnetic models. Permanent mount models can also be synchronized to operate multiple lights alternately or simultaneously.

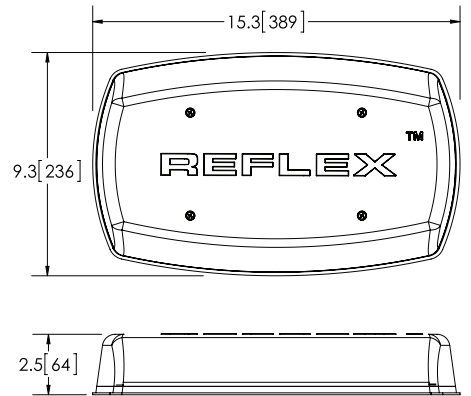

Models

PART NO.	DOMES COLOR	ILLUMINATION	VOLTAGE	AMPS	MOUNT
5587A	Amber	Amber	12-24	5.1	Permanent
5587A-MG	Amber	Amber	12-24	5.1	Magnet
5587A-VM	Amber	Amber	12-24	5.1	Vacuum-Magnet
5587CA	Clear	Amber	12-24	5.1	Permanent
5587CA-MG	Clear	Amber	12-24	5.1	Magnet
5587CA-VM	Clear	Amber	12-24	5.1	Vacuum-Magnet
5587CAC	Clear	Amber	12-24	5.1	Permanent
5587CAC-MG	Clear	Amber	12-24	5.1	Magnet
5587CAC-VM	Clear	Amber	12-24	5.1	Vacuum-Magnet

Replacement Parts

- Domes: Amber - EZ5507LA
Clear - EZ5507LC

Features and Benefits

- Eight LED reflector modules, each comprising three LEDs provide high intensity light output
- Choice of 18 flash patterns
- Synchronization capable (permanent mount only)
- Cigarette plug with on/off and flash pattern selection switch (vacuum-magnet & magnet only)
- Polycarbonate base & low profile lens
- SAE J845 Class I, CE, R10, IP65 (permanent mount only), California Title 13 (CA only)
- Temperature Range: -22°F to +122°F (-30°C to +50°C)
- Warranty: 3 years