

MINIBARS | LIGHTBARS | DIRECTIONALS | WORKLAMPS | UTILITY BARS | INTERIOR LIGHTING | BACK-UP ALARMS | CAMERA SYSTEMS

## BEACONS

### 7945 SERIES SAE Class II LED

The 7945 Series beacon combines all the major benefits of the latest LED technology with a traditional, strobe style housing at a price point comparable to a strobe. Available in either 5" or 7" height profiles the 7945 is suitable for a wide range of applications where an SAE Class II light is required. The 7945 features 12-48VDC operation and 11 flash patterns to produce an attention getting warning signal. 2-year warranty.

#### Models

PART NO.	VOLTAGE	AMPS	PROFILE	COLOR	MOUNT
7945X	12-48	1.3	5"	Choose	3 Bolt Flange/1" Pipe
7945X-VM	12-48	1.3	5"	Choose	Vacuum Magnet
7950X	12-48	1.3	7"	Choose	3 Bolt Flange/1" Pipe
7950X-VM	12-48	1.3	7"	Choose	Vacuum Magnet

Replace X in part number with desired color: A = amber, B = blue, C = clear, G = green, R = red

#### Features and Benefits

- 11 flash patterns
- Reinforced polypropylene base, polycarbonate lens
- Switched cigarette plug adapter (vacuum-magnet models)
- Rechargeable battery powered model available in amber
- SAE J845 Class II (A & C only), CE, R10
- Temperature Range: -22°F to +122°F (-30°C to +50°C)
- Warranty: 2 years

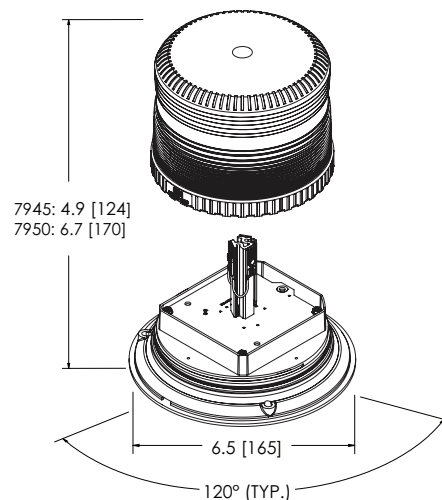

#### Parts & Accessories

- Lenses: 7945 - R6050LX  
7950 - R6070LX

Replace X in part number with desired color:  
A = amber, B = blue, C = clear, G = green, R = red