

## TECHNICAL SPECIFICATIONS

### SOLID COLOR:

INPUT VOLTAGE .....	10 to 30 Volts DC.
INPUT CURRENT .....	1.25A @ 12.8V, 0.6A @ 25.6V
LIGHT OUTPUT .....	AMBER: 358+ LUMENS
	BLUE: 240+ LUMENS
	GREEN: 312+ LUMENS
	RED: 358+ LUMENS
	CLEAR, PURPLE: 1100+ LUMENS

### SPLIT COLOR:

INPUT VOLTAGE .....	10 to 30 Volts DC.
INPUT CURRENT .....	0.6A @ 12.8V, 0.3A @ 25.6V
LIGHT OUTPUT .....	AMBER: 180+ LUMENS
(For each 3 LED group)	BLUE: 120+ LUMENS
	GREEN: 104+ LUMENS
	RED: 180+ LUMENS
	CLEAR: 550+ LUMENS
CABLE LENGTH .....	9 FT.
LED ELEMENTS .....	6
FLASH PATTERNS .....	16 (8 Standard, 8 optional cycle)
MAX NUMBER OF	
SYNCHRONIZED HEADS .....	64
WARRANTY PERIOD .....	5 YEARS

## DIMENSIONS

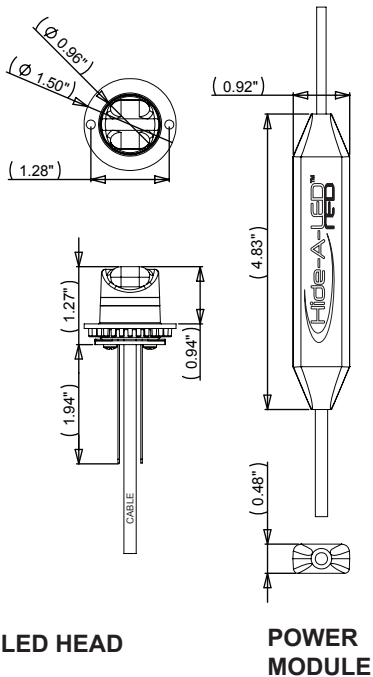

LED HEAD

POWER MODULE

## ITEMS INCLUDED

- (1) HIDE-A-LED™ HEAD WITH INTEGRATED HEATSINK, BUILT IN POWER MODULE AND 9' CABLE.
- (1) MOUNTING GASKET
- (2) #6 X 1/2" STAINLESS STEEL MOUNTING SCREWS



## MOUNTING

Drill a 1" diameter hole in the reflector of the lens assembly. A 1" hole saw is typically used. The HIDE-A-LED™ may be used as a template to mark the location of the two screw holes. The 9013 may be mounted in either the back surface, bottom or sides of a reflector. Drill pilot holes with a 7/64" drill bit. Install the HIDE-A-LED™ into the lens assembly using the supplied gasket and screws. If the mounting surface is curved additional sealing may be necessary. Use RTV Silicone sealant if needed.

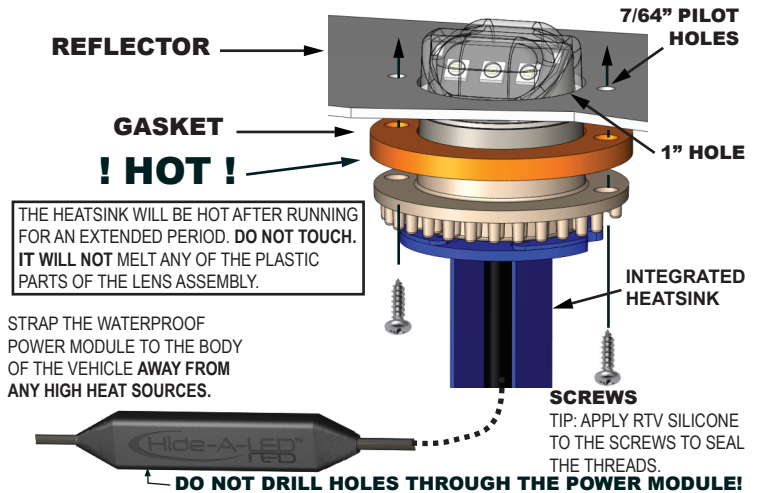

THE 9013 HAS AN INTEGRATED HEATSINK WHICH MUST BE USED TO MAINTAIN A SAFE OPERATING TEMPERATURE.

**! THE HEATSINK MUST NOT BE REMOVED !**

THE HEATSINK CAN BE BENT INTO ANY SHAPE NEEDED TO FIT THE SPACE AVAILABLE FOR THE APPLICATION.

## ELECTRICAL CONNECTIONS

The cable on the HIDE-A-LED™ was made long enough to run across the front or the rear of a vehicle. Trim the cable shorter if needed. The wiring diagram on page 2 shows a typical install.

### RED: +V

Connect to +V through an ON/OFF switch. The use of a fuse located close to the voltage source is recommended. Size the fuse according to the number of heads used in the system. 18AWG or larger wire is recommended.

### BLACK: - GROUND

Connect to - GROUND vehicle chassis. 18AWG or larger wire is recommended.

### BLUE: Flash pattern SYNC and SELECTION wire.

If you wish to have all the LED heads synchronize their flash timings and patterns with each other then all the BLUE wires must be connected together. (64 Heads Maximum)

The BLUE wire is also used to select the flash pattern.

Touch the BLUE wire to +V to select the next pattern in the FLASH PATTERN LIST. The BLUE wire can also be run to a momentary push-button located on the dashboard to allow the flash pattern to be changed when desired.

**Note: Do not connect the BLUE wire to - Ground. It will disrupt the flash pattern sync signal.**

## ELECTRICAL CONNECTIONS

### YELLOW: Alternating / Simultaneous selection.

(It is assumed that all BLUE wires are connected together.)

Connect to either +V or GROUND (GND).

Heads with YELLOW connected to +V fire at the same time.

Heads with YELLOW connected to GND fire at the same time.

Heads with YELLOW connected to +V will ALTERNATE with heads that have YELLOW connected to GND.

### SPLIT COLOR HEADS:

9013 heads with 2 colors always alternate from side to side within themselves. The YELLOW wire reverses the direction so that two heads can either flash the same color at the same time or different colors at the same time.

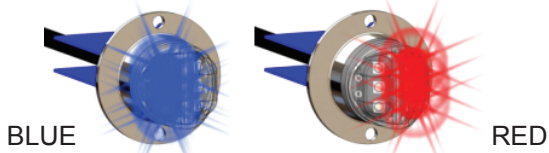

## ELECTRICAL CONNECTIONS

INSTALLATION OF 4 HIDE-A-LED™ USING AN ON/OFF SWITCH AS WELL AS A MOMENTARY SWITCH TO SELECT FLASH PATTERNS (NOT SUPPLIED)

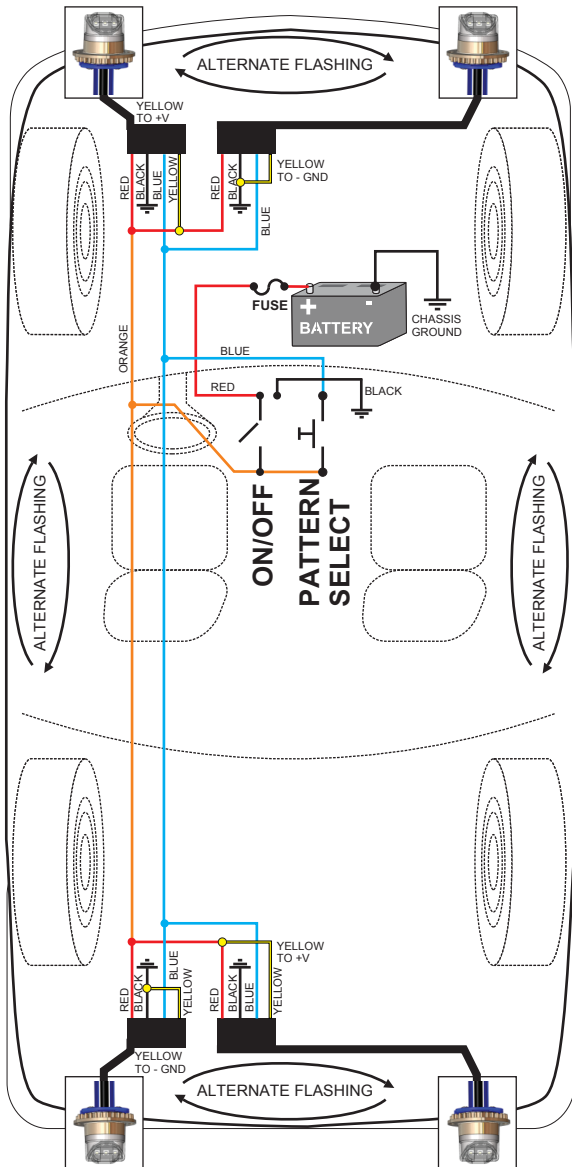

## FLASH PATTERNS

### POWER-UP RESET:

After installing the system it is best to do a POWER-UP RESET the first time to ensure that all heads are in sync.

Touch **BLUE** wires to +V (**RED** wire) while applying power.

Release **BLUE** wires. All heads will reset to Pattern #2.

If you have installed a pattern select push-button, press and hold pattern select while turning power switch ON.

To select a flash pattern, touch BLUE to +V or press pattern select switch to increment the flash pattern. The heads will remember the selected pattern even if power is removed.

STANDARD PATTERNS			
#	Pattern:	Frequency:	Description:
1	Quad Flash	1.25 Hz	75 Quad Flashes Per Minute
2	Double Flash	1.25 Hz	75 Double Flashes Per Minute
3	Triple Flash	1.53 Hz	92.3 Triple Flashes Per Minute
4	DeciBlast	1.42 Hz	85.5 Deci Flashes Per Minute
5	Single Flash	1.25 Hz	75 Single Flashes Per Minute
6	Mega Flash	1.90 Hz	114 Single Flashes Per Minute
7	Triple+Burst	1.37 Hz	82.5 Triple+Burst Flashes Per Minute
8	Steady On		Steady on. Split Color = Fast Mega
CYCLE PATTERNS			
9	Cycle All		Cycle through patterns 1 to 7
10	Double-Triple+Burst		2 Double, 2 Triple+Burst cycle
11	Cycle Classic		1 Double, 1 Quad, 2 Mega cycle
12	Quad-Mega		3 Quad, 4 Mega cycle
13	Single-Quad		2 Single, 2 Quad cycle
14	DeciBlast-Quad		2 DeciBlast, 2 Quad cycle
15	Single-Triple-DeciBlast		2 Single, 2 Triple, 2 DeciBlast cycle
16	Mega-Triple+Burst		1 Mega, 1 Triple+Burst cycle

### STANDARD PATTERNS:

The HIDE-A-LED™ ships with only the standard patterns enabled. To enable cycle flash patterns follow the procedure below.

### CYCLE PATTERNS:

You may add patterns 9 through 16 by following this procedure:

1) Touch **BLUE** wires to +V (**RED** wire) while applying power.

If you have installed a pattern select push-button, press and hold pattern select while turning power switch ON.

2) Hold **BLUE** wires on +V for 5 SECONDS (heads will not be flashing during this time). After 5 SECONDS the heads will flash once or twice to indicate the flash pattern list that has been selected:

**ONE FLASH** = Standard Patterns only.

**TWO FLASHES** = Standard + Cycle Patterns.

3) Remove the BLUE wires from +V (or release push-button).

You may switch the pattern set at any time as many times as you wish. All heads will remember the pattern set that was selected even when power is removed.

## TROUBLESHOOTING

### HEAD NOT FLASHING:

Check the RED and BLACK wires for a reversed connection. (Reverse connection will not damage the unit). Check RED and BLACK wires for either a bad splice or a corroded ground connection.

### HEADS NOT SYNCHRONIZING:

Check for a short circuit on the BLUE wire to either +V or GROUND. Saltwater on the wire connections will short circuit the sync signal on the BLUE wire. Check for non-functional heads in the system. If any one of the heads has a bad GROUND connection it can cause the sync signal to become corrupted. If any one of the heads has it's RED and BLACK wires reverse connected it will corrupt the sync signal.

### FLASH PATTERN CHANGING:

If the flash pattern changes on it's own there may be an intermittent short between the BLUE wire and +V. Check for water in the wiring connections. If any one of the heads in the system has an intermittent GROUND connection it can also cause the flash pattern to change.