

REVISION HISTORY		
REV.	DESCRIPTION	DATE
A	INITIAL RELEASE PER EC5750	2020-06-24
B	REVISED PER EC5750	2020-08-11
C	REVISED PER EC5750	2020-08-26

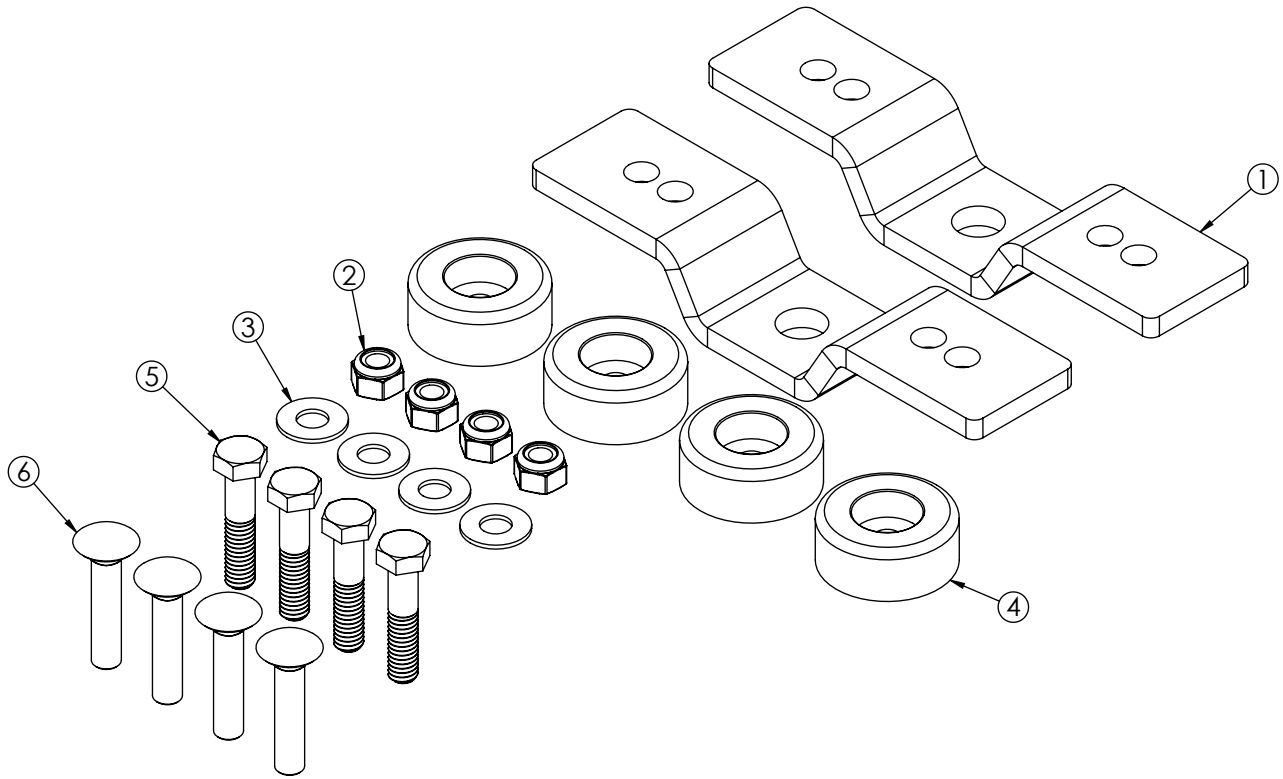

ITEM NO.	QTY.	PART NUMBER	DESCRIPTION	COMMENTS
1	2	220-1184-00	BRACKET,SS,WRECKER,TRANSITION	
2	4	310-0077-00	NUT,HEX,5/16"-18,NYLOC,316,SS	
3	4	340-0063-00	WASHER,FLAT,5/16",316,SS	
4	4	400-0195-00	BUMPER,RUBBER,1.5"OD,5/16"ID,5/8"THK	
5	4	330-0069-00	BOLT,5/16"-18X1.5",HEX,316SS	
6	4	330-0027-01	BOLT,5/16"-18X1.5",CARRIAGE,316SS	
7	1	920-0869-00	SHEET,INSTRUCTION,A1032RMK,MNT,KIT	NOT SHOWN
8	1	BAG-600	BAG,POLY,5" X 7"	NOT SHOWN
9	1	BOX-361	BOX,4 1/8X3 1/4X7 1/4,.028,SUB,AUTO BTM	NOT SHOWN

APPROVALS	DATE
DRAWN BY JLA	2020-08-21
CHECKED ART	2020-08-24
MECH. ENG. NMT	2020-08-24
ELEC. ENG.	
MFG. ENG. JMS	2020-08-25



ACCESSORY,RACK MOUNT KIT,10 15 20 30 SER A1032RMK

SCALE 1:2
 CAD GENERATED DRAWING
 DO NOT MANUALLY UPDATE.
 MODEL REFERENCED: 01

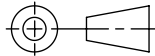

Electronically Controlled Use Latest Copy

SIZE: A	DWG. NO. A1032RMK	REV. C
SHEET 1 OF 1	Project: EC5750	Date Created: 2019-12-17

PROPRIETARY AND CONFIDENTIAL INFORMATION
 THIS DRAWING AND THE DESIGN AND OTHER INFORMATION DISCLOSED HEREIN ARE THE PROPERTY OF ELECTRONIC CONTROLS COMPANY AND/OR ITS ECCO SAFETY GROUP AFFILIATES ("ESG") AND IS ISSUED IN CONFIDENCE TO RECIPIENT FOR ENGINEERING INFORMATION PURPOSES ONLY. THIS DRAWING AND THE DESIGN AND OTHER INFORMATION DISCLOSED HEREIN MAY NOT BE USED, COPIED, REPRODUCED OR OTHERWISE DISCLOSED IN PART OR IN WHOLE TO THIRD PARTIES OR USED FOR ANY OTHER PURPOSE WITHOUT PRIOR ESG WRITTEN CONSENT. ESG RESERVES ALL PATENT, COPYRIGHT, TRADEMARK AND OTHER PROPRIETARY RIGHTS TO THIS DOCUMENT, INCLUDING ALL DESIGN, MANUFACTURING, REPRODUCTION, USE AND SALES RIGHTS THERETO. THIS DRAWING IS SUBJECT TO RECALL BY ESG AT ANY TIME, AND YOUR POSSESSION AND/OR USE CONSTITUTES ACCEPTANCE OF THESE TERMS.
 ©2019 ELECTRONIC CONTROLS COMPANY