



Installation and Operation Instructions

Directional Sensor

Introduction:

The ECCO DS1500 is a solid-state reverse motion sensor which can be used on vehicles with any type of speedometer, including electronic. It activates the back-up alarm every time the vehicle moves backwards, in any gear, ignition on or off. The DS1500 meets the California alarm device requirements for refuse trucks.

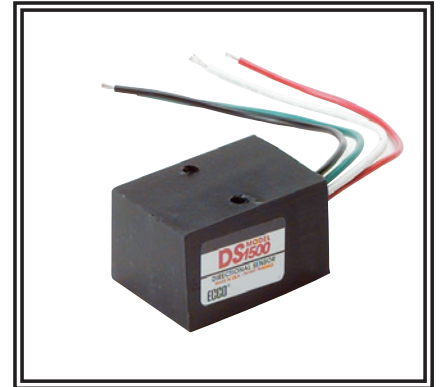

PARTS LIST

ITEM	REQ'D	DESCRIPTION
1	1	3 1/2" x 7/16" - 20 G5 HEX HD BOLT
2	1	SPACER 1 5/8" x 1/2" SCH.160 PIPE
3	10	7/16" FLAT WASHER
4	1	7/16" - 20 "NYLOK" NUT
5	2	LOCK PLATE/MAGNET ASSEMBLY
6	2	3/4" x 1/4" - 28 HEX HEAD BOLT
7	4	1/4" FLAT WASHER
8	4	1/4" - 28 "NYLOK" NUT
9	TAPE - 3/4" x 10' MR98	
10	1	REINFORCEMENT STRAP
11	2	2 1/4" x 1/4" - 28 HEX HEAD BOLT
12	1	LONG BRACKET 1 3/4" x 9"
13	1	SHORT BRACKET 1 3/4" x 4 1/2"
14	1	SENSOR ASSEMBLY
15	2	MAGNET, TAPE ON

IMPORTANT! Read all instructions before installing and using. Installer: This manual must be delivered to the end user.

! WARNING!
 Failure to install or use this product according to manufacturers recommendations may result in property damage, serious bodily/personal injury, and/or death to you and those you are seeking to protect!



Do not install and/or operate this safety product unless you have read and understand the safety information contained in this manual.

1. Proper installation combined with operator training in the use, care, and maintenance of emergency warning devices are essential to ensure the safety of you and those you are trying to protect.
2. Exercise caution when working with live electrical connections.
3. This product must be properly grounded. Inadequate grounding and/or shorting of electrical connections can cause high current arcing, which can cause personal injury and/or severe vehicle damage, including fire.
4. Proper placement and installation are vital to the performance of this warning device. Install this product so that output performance of the system is maximized and the controls are placed within convenient reach of the operator so that s/he can operate the system without losing eye contact with the roadway.
5. It is the responsibility of the vehicle operator to ensure during use that all features of this product work correctly. In use, the vehicle operator should ensure the projection of the warning signal is not blocked by vehicle components (i.e., open trunks or compartment doors), people, vehicles, or other obstructions.
6. The use of this or any other warning device does not ensure all drivers can or will observe or react to a warning signal. Never take the right-of-way for granted. It is your responsibility to be sure you can proceed safely before entering an intersection, driving against traffic, responding at a high rate of speed, walking on or around traffic lanes.
7. This equipment is intended for use by authorized personnel only. The user is responsible for understanding and obeying all laws regarding warning signal devices. Therefore, the user should check all applicable city, state, and federal laws and regulations. The manufacturer assumes no liability for any loss resulting from the use of this warning device.
8. This product contains high intensity LEDs, staring directly into these lights could result in temporary and/or permanent vision impairment.

Unpacking:

Carefully remove the sensor and other components, and check for damaged or missing parts (see the front cover of this installation manual for a parts list and description). If missing or defective parts are found, contact the transit company or ECCO immediately.

Installation:

The magnets in the DS1500 sensor system may be mounted using either the “tape-on” method (A), where the magnets are taped directly onto the drive line, or the “bolt-on” method (B), where the magnet assemblies are bolted onto the U-joint caps. See Figure 2 on page 3.

(“A”) Tape-on Mounting:

1. Clean and degrease drive line in area where magnets will be mounted. Steel wool and no-residue solvent works well (brake cleaner, electrical contact cleaner, etc.).
2. Find two opposite points on the drive line by using a paper strip to divide the circumference of the drive shaft in half. Wrap the paper strip tightly around the drive line and cut off excess where the strip overlaps itself. Align the ends of the strip and fold in half. Lay strip around the drive line and make marks on the shaft next to the ends of the strip and next to the fold point using a felt tip marker.
3. Place the magnets 180° apart using the marks made in step 2. A strip of masking or electrical tape temporarily around the drive line can act as a guide to help position the magnets exactly opposite each other.
4. Apply the supplied thermosetting tape over the magnets as shown in Figure 1.

(“B”) Bolt-on Mounting:

1. Install the lock plate / magnet assemblies on opposite caps of the U-joint.

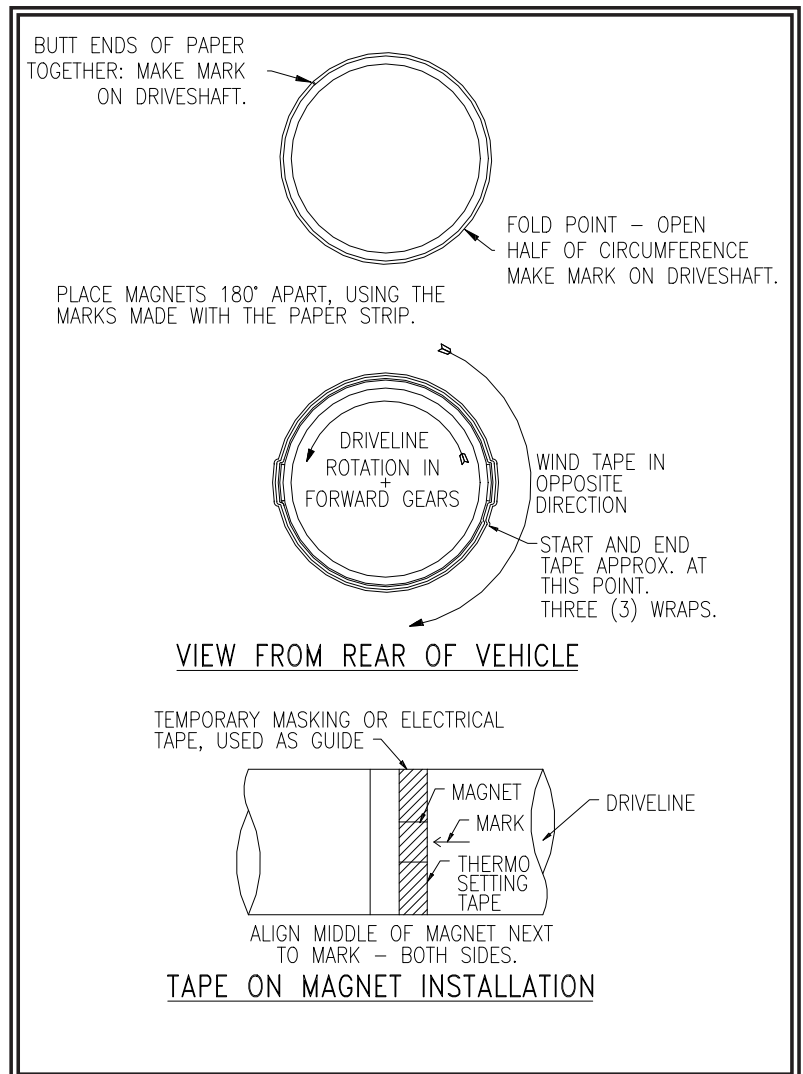

Figure 1

Sensor Mounting:

When installing the DS1500 sensor to the mounting bracket, use hand tools only. Do not use pneumatic or electric power tools. Be sure to install the reinforcement strap. Seat nylock nuts until contact is made with reinforcement strap. Alternately tighten each nut 1/2 turn at a time until sensor body is securely fastened to bracket. **Do not over tighten bolts. Do not mount near exhaust system.**

NOTE:

The design of the DS1500 has changed. If replacing or installing this sensor/magnet for the first time, please be sure to follow the gap adjustment instructions in 4.

1. Replace OEM bolt on carrier bearing with the supplied longer grade 5 bolt.
2. Mount brackets and sensor assembly as shown in figure 2, using the washers to position the height of the sensor.
3. The sensor must be mounted such that the magnet proceeds from the black wire to the red wire when the driveline rotates in reverse.
4. Adjust the air gap between the sensor face and the magnets to be around $\varnothing 0.323"$. A 5/16" or 8mm drill bit may be used as a gap adjustment tool. A "P" sized drill from a lettered drill bit set is preferred.

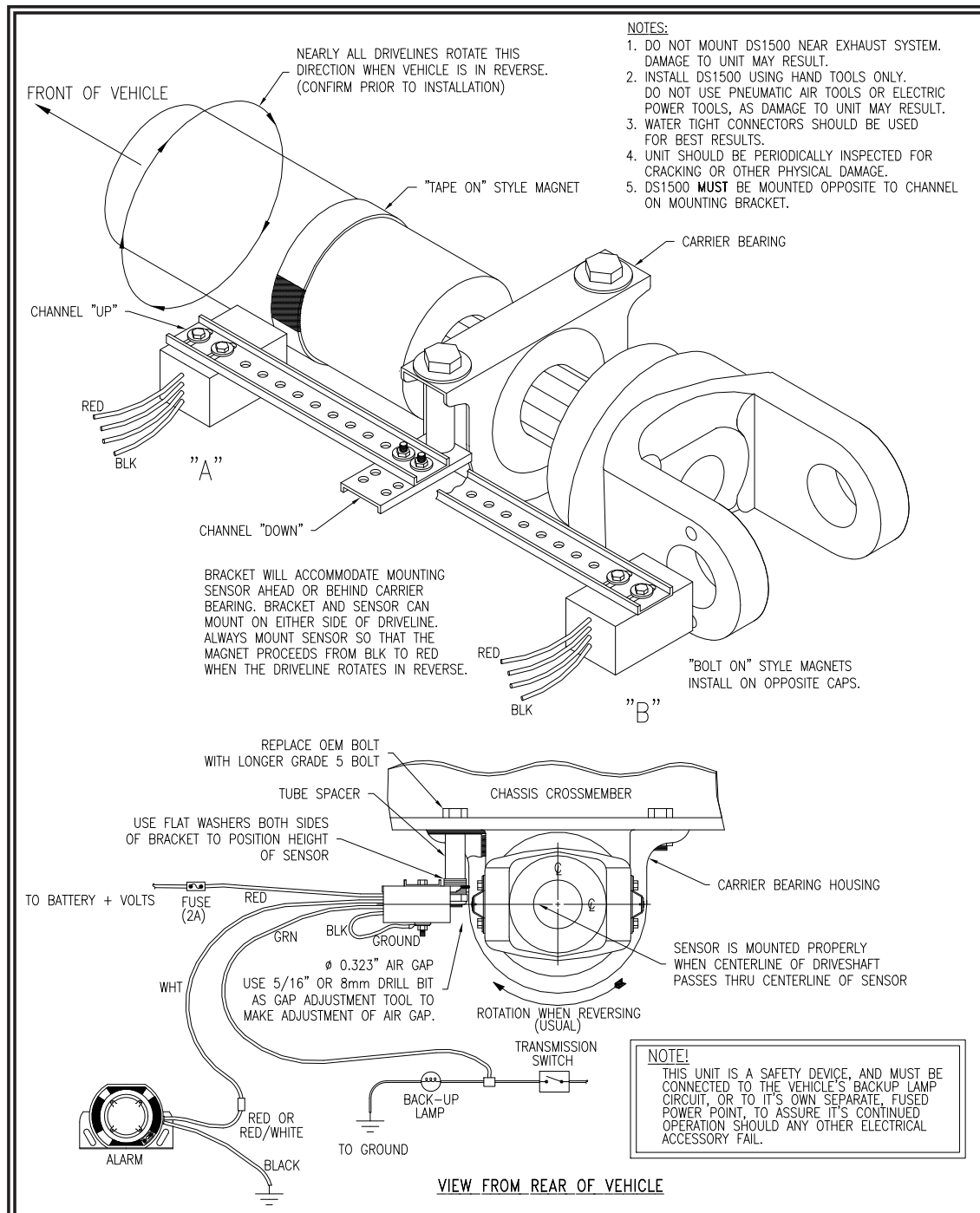

Figure 2

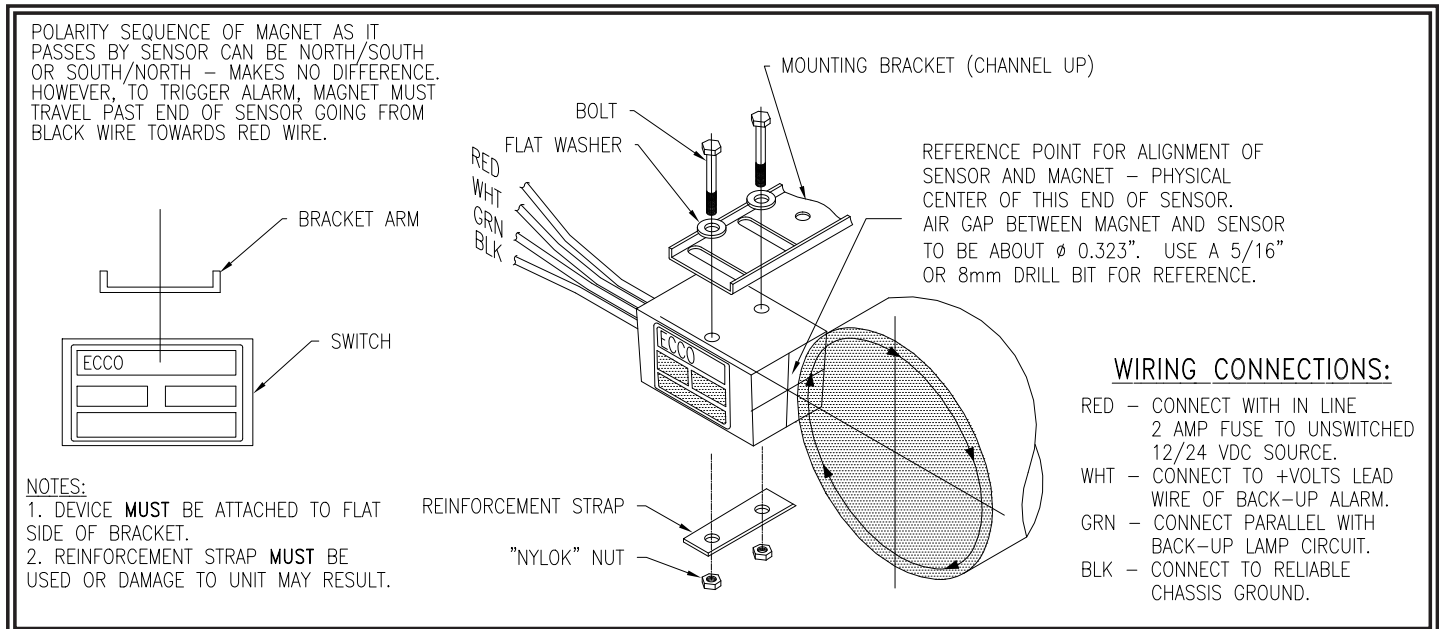

Figure 3

Manufacturer Limited Warranty and Limitation of Liability:

Manufacturer warrants that on the date of purchase this product will conform to Manufacturer's specifications for this product (which are available from the Manufacturer upon request), and Manufacturer further warrants that this product is free from defects in materials and workmanship. This Limited Warranty extends for twenty-four (24) months from the date of manufacture. Other warranties may apply, call Manufacturer for details. Manufacturer will, at its discretion, replace or repair any product found by the Manufacturer to be defective and subject to this Limited Warranty.

DAMAGE TO PARTS OR PRODUCTS RESULTING FROM TAMPERING, ACCIDENT, ABUSE, MISUSE, NEGLIGENCE, UNAPPROVED MODIFICATIONS, FIRE, OR OTHER HAZARD; IMPROPER INSTALLATION OR OPERATION; OR NOT BEING MAINTAINED IN ACCORDANCE WITH THE MAINTENANCE PROCEDURES SET FORTH IN MANUFACTURER'S INSTALLATION AND OPERATING INSTRUCTIONS VOIDS THIS LIMITED WARRANTY.

ORAL STATEMENTS OR REPRESENTATIONS ABOUT THE PRODUCT WHICH MAY HAVE BEEN MADE BY SALESPeOPLE, DEALERS, AGENTS, OR OTHER MANUFACTURER'S REPRESENTATIVES DO NOT CONSTITUTE WARRANTIES. THIS LIMITED WARRANTY MAY NOT BE AMENDED, MODIFIED, OR ENLARGED, EXCEPT BY A WRITTEN AGREEMENT SIGNED BY AN AUTHORIZED OFFICIAL OF MANUFACTURER WHICH EXPRESSLY REFERS TO THIS LIMITED WARRANTY.

Exclusion of Other Warranties:

MANUFACTURER MAKES NO OTHER WARRANTIES, EXPRESS OR IMPLIED. THE IMPLIED WARRANTIES FOR MERCHANTABILITY OR FITNESS FOR A PARTICULAR PURPOSE ARE HEREBY EXCLUDED AND SHALL NOT APPLY TO THE PRODUCT. BUYER'S SOLE AND EXCLUSIVE REMEDY IN CONTRACT, TORT, OR UNDER ANY OTHER THEORY AGAINST MANUFACTURER REGARDING THE PRODUCT AND ITS USE SHALL BE THE REPLACEMENT OR REPAIR OF THE PRODUCT AS DESCRIBED ABOVE.

Limitation of Liability:

IN THE EVENT OF LIABILITY FOR DAMAGES ARISING OUT OF THIS LIMITED WARRANTY OR ANY OTHER CLAIM RELATED TO THE MANUFACTURER'S PRODUCTS, MANUFACTURER'S LIABILITY FOR DAMAGES SHALL BE LIMITED TO THE AMOUNT PAID FOR THE PRODUCT AT THE TIME OF THE ORIGINAL PURCHASE. IN NO EVENT SHALL MANUFACTURER BE LIABLE FOR LOST PROFITS, THE COST OF SUBSTITUTE EQUIPMENT OR LABOR, PROPERTY DAMAGE, OR OTHER SPECIAL, CONSEQUENTIAL, OR INCIDENTAL DAMAGES BASED UPON ANY CLAIM FOR BREACH OF CONTRACT, IMPROPER INSTALLATION, NEGLIGENCE, OR OTHER CLAIM, EVEN IF MANUFACTURER OR A MANUFACTURER'S REPRESENTATIVE HAS BEEN ADVISED OF THE POSSIBILITY OF SUCH DAMAGES. MANUFACTURER SHALL HAVE NO FURTHER OBLIGATION OR LIABILITY WITH RESPECT TO THE PRODUCT OR ITS SALE, OPERATION AND USE, AND MANUFACTURER NEITHER ASSUMES NOR AUTHORIZES THE ASSUMPTION OF ANY OTHER OBLIGATION OR LIABILITY IN CONNECTION WITH SUCH PRODUCT.

This Limited Warranty defines specific legal rights. You may have other legal rights which vary from state to state. Some states do not allow the exclusion or limitation of incidental or consequential damages.