

BEACONS

EB7180 SERIES SAE Class I LED

The EB7180 LED provides the ultimate level of power, versatility and style available in an LED beacon. The latest high-intensity LEDs combine with reflector technology to produce a powerful, SAE Class I warning signal in a square housing that also offers premium features, including multiple flash patterns and synchronization capability. Featuring 12-24 VDC operation and eight flash patterns, the EB7180 Series is suitable for a wide range of applications where a high-intensity SAE Class I light is required. Each unit is backed by a 3-year warranty.

Models

PART NO.	VOLTAGE	AMPS	LENS/ILLUMINATION	MOUNT
EB7180A	12-24	6.2	Amber	4 Bolt Flange
EB7180A-VM	12-24	6.2	Amber	Vacuum Magnet
EB7180CA	12-24	6.2	Clear/Amber	4 Bolt Flange
EB7180CA-VM	12-24	6.2	Clear/Amber	Vacuum Magnet
EB7180CC	12-24	6.2	Clear	4 Bolt Flange
EB7180CC-VM	12-24	6.2	Clear	Vacuum Magnet

Features and Benefits

- Compact, low profile beacon
- 8 flash patterns including simulated rotate
- Multiple units can be synchronized
- Cigarette plug with on/off and flash pattern switch (vacuum magnet only)
- SAE J845 Class I, Cal. Title 13, R10, IP55, AMECA
- Temperature Range: -22°F to +122°F (-30°C to +50°C)
- Warranty: 3 years

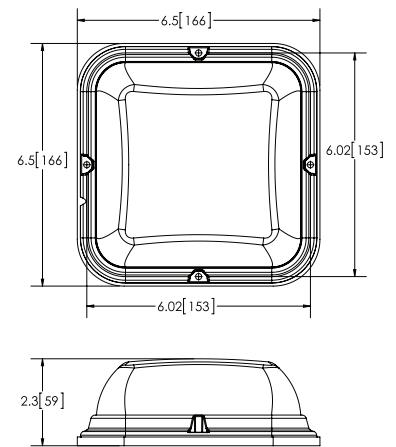

Flash Patterns (8)

- Single, 125 FPM
- Double, 125 FPM
- Quad, 125 FPM
- Rotate, 125 FPM
- Single, 75 FPM
- Double, 75 FPM
- Quad, 75 FPM
- Rotate, 75 FPM