



ECCO[®]

Installation and Operation Instructions 360° LED Beacon

ECCO's EB7930 & EB7935 Series LED beacons are specifically designed for use in the most demanding applications, including those where severe vibration is present. These beacons meet SAE J845 Class II specifications and feature encapsulated electronics to provide superior protection against dust and moisture ingress as well as vibration and minor impacts. Available in 5" (7930) or 7" (7935) height profiles, specifications include 12-48 VDC operation and a reinforced nylon base with 3 bolt mounting flange and an integrated 1" pipe mount.



IMPORTANT! Read all instructions before installing and using. Installer: This manual must be delivered to the end user.



WARNING!

Failure to install or use this product according to manufacturers recommendations may result in property damage, serious bodily/personal injury, and/or death to you and those you are seeking to protect!



Do not install and/or operate this safety product unless you have read and understand the safety information contained in this manual.

1. Proper installation combined with operator training in the use, care, and maintenance of emergency warning devices are essential to ensure the safety of you and those you are trying to protect.
2. Exercise caution when working with live electrical connections.
3. This product must be properly grounded. Inadequate grounding and/or shorting of electrical connections can cause high current arcing, which can cause personal injury and/or severe vehicle damage, including fire.
4. Proper placement and installation are vital to the performance of this warning device. Install this product so that output performance of the system is maximized and the controls are placed within convenient reach of the operator so that s/he can operate the system without losing eye contact with the roadway.
5. It is the responsibility of the vehicle operator to ensure during use that all features of this product work correctly. In use, the vehicle operator should ensure the projection of the warning signal is not blocked by vehicle components (i.e., open trunks or compartment doors), people, vehicles, or other obstructions.
6. The use of this or any other warning device does not ensure all drivers can or will observe or react to a warning signal. Never take the right-of-way for granted. It is your responsibility to be sure you can proceed safely before entering an intersection, driving against traffic, responding at a high rate of speed, walking on or around traffic lanes.
7. This equipment is intended for use by authorized personnel only. The user is responsible for understanding and obeying all laws regarding warning signal devices. Therefore, the user should check all applicable city, state, and federal laws and regulations. The manufacturer assumes no liability for any loss resulting from the use of this warning device.

Specifications:

Size: EB7930: 6.0" dia. x 4.8" high
EB7935: 6.0" dia. x 6.8" high

Weight: approx. 3 lbs.

Input Voltage: 12-48 VDC system

Input Current:
1.3A @ 12.8 VDC
Maximum power consumption: 16 Watts

Temp. Range: -30°C to +50°C

Installation & Mounting:

Important! This unit is a safety device, and it must be connected to its own separate, fused power point to assure its continued operation should any other electrical accessory fail.

Carefully remove the beacon and place it on a flat surface. Examine the unit for transit damage, and locate all parts. If damage is found, or parts are missing, contact the transit company or ECCO. Do not use damaged or broken parts.



Caution: When drilling into any vehicle surface, make sure that the area is free from any electrical wires, fuel lines, vehicle upholstery, etc. that could be damaged.

Permanent Mounting:

Select the desired location on a flat surface for the LED beacon to be mounted. The visibility of the flash and ease of wiring access should be taken into consideration in the selection of the mounting location.

1. Using the base gasket as a template, mark the three mounting hole locations (see Figure 1).
2. Drill the holes using a 7/32" drill size.
3. A fourth hole may be drilled for wire access as shown in Figure 1, or the wires may be routed through the slot in the base for external access.
4. Connect the power wires as shown in the wiring section (see Figure 2).
5. Mount the beacon with #10 hardware.

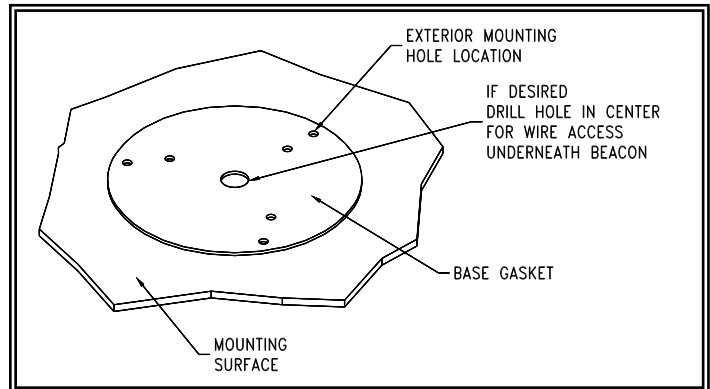

Figure 1

Pipe Mounting:

The EB7930 & EB7935 series base comes with 1" NPT threads for pipe mounting.



WARNING!

Failure to follow these instructions can result in fire or injury from excessive heat build up.

Operator is responsible for ensuring cigarette adapter fits correctly into cigarette/auxillary outlet used. For proper operation, verify cigarette/auxillary outlet circuit is rated to supply, a minimum of 10 amps. (See specifications section for rated current in amperes).
Do not exceed the current rating for the cigarette lighter power outlet recommended by vehicle manufacturer.
Keep cigarette lighter adapter, and outlet, clean and free of debris.
Do not use the cigarette lighter adapter when wet.
Insert cigarette lighter adapter fully into the outlet for proper connection.
Grasp cigarette lighter adapter, NOT cord, to remove from outlet.
Remove cigarette lighter adapter completely from outlet when light is not in use.

Wiring Instructions:

Notes:

1. Larger wires and tight connections will provide longer service life for components. For high current wires it is highly recommended that terminal blocks or soldered connections be used with shrink tubing to protect the connections. Do not use insulation displacement connectors (e.g., 3M Scotchlock type connectors).
2. Route wiring using grommets and sealant when passing through compartment walls. Minimize the number of splices to reduce voltage drop. High ambient temperatures (e.g., under-hood) will significantly reduce the current carrying capacity of wires, fuses, and circuit breakers. All wiring should conform to the minimum wire size and other recommendations of the manufacturer and be protected from moving parts and hot surfaces. Looms, grommets, cable ties, and similar installation hardware should be used to anchor and protect all wiring.
3. Fuses or circuit breakers should be located as close to the power takeoff points as possible and properly sized to protect the wiring and devices.
4. Particular attention should be paid to the location and method of making electrical connections and splices to protect these points from corrosion and loss of conductivity.
5. Ground termination should only be made to substantial chassis components, preferably directly to the vehicle battery.
6. Circuit breakers are very sensitive to high temperatures and will "false trip" when mounted in hot environments or operated close to their capacity.

Important: Disable power before wiring the beacon.

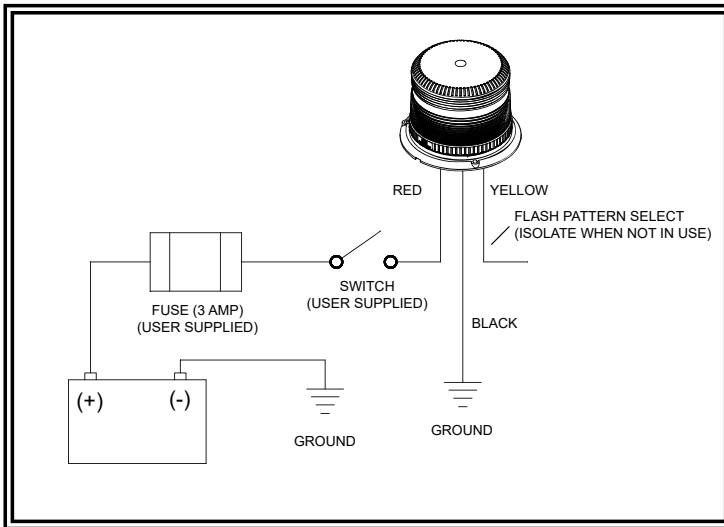

Figure 2

Flash Patterns:

Photometric Summary Table						
Sequence	Description	FPM	AMBER	BLUE	WHITE	RED
1	Single	65	CLASS 2	CLASS 3	CLASS 2	-
2	Single	120	CLASS 2	CLASS 3	CLASS 2	-
3	Double	80	CLASS 2	CLASS 3	CLASS 2	-
4	Double	120	CLASS 2	CLASS 3	CLASS 2	-
5	Triple	75	CLASS 2	CLASS 3	CLASS 2	-
6	Quad	75	CLASS 2	CLASS 3	CLASS 2	-
7	Quad	120	CLASS 2	CLASS 3	CLASS 2	-
8	Quint/Hold	75	CLASS 2	CLASS 3	CLASS 2	-
9	Pulse8	75	CLASS 2	CLASS 3	CLASS 2	-
10	Random	N/A	N/A	N/A	N/A	N/A
11	Steady On	N/A	N/A	N/A	N/A	N/A

Maintenance:

This LED beacon has been designed for trouble free operation. There are no periodic maintenance needs for this model.

Troubleshooting:

1. Most beacon failures, including intermittent or erratic operation as well as failure of operation can be traced to wiring or battery problems. Check all wiring, connections, fuse, switch, and battery voltage to insure that the correct voltage is reaching the beacon.
2. If this has not remedied the problem, return product to your local dealer for warranty replacement, or call ECCO Customer Service for assistance (800) 635-5900.

Note: Operating the vehicle without the lens installed on this product will result in damage that will not be covered under warranty.

Replacement Parts & Accessories:

Description	Part Number
Lens, 4"	R6050LX*
Lens, 6"	R6070LX*
Self Leveling Bracket	A6600SLB
Branch Guard	A6050BG
Branch Guard	A6070BG
Dust Cover	A6050DC
Dust Cover	A6070DC
Vibration Dampening Kit	A6600VDK
Black Top Decal	A6501BT

*where (X) indicates color: A = Amber
B = Blue
C = Clear
G = Green
R = Red