



BEACONS | MINIBARS | LIGHTBARS | WORKLAMPS | UTILITY BARS | INTERIOR LIGHTING | BACK-UP ALARMS | CAMERA SYSTEMS

## DIRECTIONALS

### ED3766 SERIES SAE Class I Dual-Color Surface Mount

The ED3766 Dual Color directional [LED warning light](#) offers the flexibility of two different color outputs within a single unit, comprised of 12 high intensity LEDs, six of each color. SAE Class I light output, synchronization capability and the choice of 11 flash patterns allows the creation of an attention-getting multi-color warning system with half the number of lights typically required. Each model can be programmed to flash either color option individually or alternate colors.

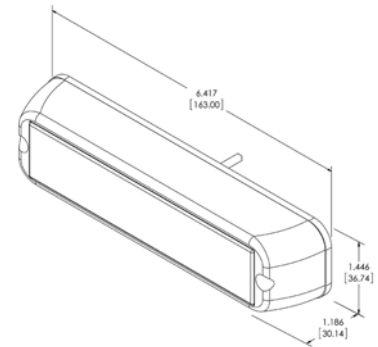

#### Models

PART NO.	COLORS	VDC	AMPS	MOUNT
ED3766AB	Amber/Blue	12-24	0.8	Surface
ED3766AC	Amber/Clear	12-24	0.8	Surface
ED3766AG	Amber/Green	12-24	0.8	Surface
ED3766AR	Amber/Red	12-24	0.8	Surface
ED3766RB	Red/Blue	12-24	0.8	Surface

#### Flash Patterns (12)

- Single
- Fast Single
- Double
- Fast Double
- Triple
- Quad
- Fast Quad
- Modulation
- Steady Burn
- 2 Double, 2 Quad, Alt
- 4 Single, 2 Triple, Alt
- 1 Double, 1 Triple, 1 Quad

#### Features and Benefits

- 12 high-intensity LEDs provide exceptional warning
- Six LEDs per color
- 11 flash patterns
- Synchronizable
- Aluminum housing, polycarbonate lens
- Encapsulated electronics
- SAE J595 Class I
- California Title 13, R65, CE, R10, IP67
- Temperature Range: -22°F to +122°F (-30°C to +50°C)
- Warranty: 3 years

