



### WARNING!

Failure to install or use this product according to manufacturer's recommendations may result in property damage, serious injury, and/or death to those you are seeking to protect!



Do not install and/or operate this safety product unless you have read and understand the safety information contained

1. Proper installation combined with operator training in the use, care, and maintenance of emergency safety devices are essential to ensure the safety of you and those you are seeking to protect.
2. Exercise caution when working with live electrical connections.
3. This product must be properly grounded. Inadequate grounding and/or shorting of electrical connections can cause high current arcing, which can cause personal injury and/or severe vehicle damage, including fire.
4. Proper placement and installation are vital to the performance of this safety device. Install this product so that output performance of the system is maximized and the controls are placed within convenient reach of the operator so that s/he can operate the system without losing eye contact with the roadway.
5. Do not install this product or route any wires in the deployment area of an air bag. Equipment mounted or located in an air bag deployment area may reduce the effectiveness of the air bag or become a projectile that could cause serious personal injury or death. Refer to the vehicle owner's manual for the air bag deployment area. It is the responsibility of the user/operator to determine a suitable mounting location ensuring the safety of all passengers inside the vehicle particularly avoiding areas of potential head impact.
6. It is the responsibility of the vehicle operator to ensure during use that all features of this product work correctly. In use, the vehicle operator should ensure the projection of the safety signal is not blocked by vehicle components (i.e., open trunks or compartment doors), people, vehicles or other obstructions.
7. The use of this or any other safety device does not ensure all drivers can or will observe or react to a warning signal. Never take the right-of-way for granted. It is your responsibility to be sure you can proceed safely before entering an intersection, driving against traffic, responding at a high rate of speed, or walking on or around traffic lanes.
8. This equipment is intended for use by authorized personnel only. The user is responsible for understanding and obeying all laws regarding warning signal devices. Therefore, the user should check all applicable city, state, and federal laws and regulations. The manufacturer assumes no liability for any loss resulting from the use of this safety device.

**NOTE:** Black die cast aluminum housing gets very hot to the touch after operating constantly for several hours.

### Specifications:

Size:		Input Current at 12.8 VDC:	
EW3109:	9.3" L X 2.0" W X 2.0" H	EW3109:	0.8 Amps
EW3120:	20.5" L X 2.0" W X 2.0" H	EW3120:	1.8 Amps
EW3132:	32.0" L X 2.0" W X 2.0" H	EW3132:	3.0 Amps
EW3208:	8.0" L X 3.0" W X 4.3" H	EW3208:	1.3 Amps
EW3214:	14.3" L X 3.0" W X 4.3" H	EW3214:	2.8 Amps
EW3225:	32.0" L X 3.0" W X 4.3" H	EW3225:	4.3 Amps
Weight:		Max Power Consumption:	
EW3109:	1.5 lbs.	EW3109:	9.7 Watts
EW3120:	3.0 lbs.	EW3120:	22.5 Watts
EW3132:	4.4 lbs.	EW3132:	40.8 Watts
EW3208:	2.2 lbs.	EW3208:	18.0 Watts
EW3214:	3.5 lbs.	EW3214:	35.1 Watts
EW3225:	5.2 lbs.	EW3225:	59.3 Watts
Input Voltage:	12-24 VDC Systems	Temperature Range:	-40° to 158°F -40° to 70°C

### Installation & Mounting:

Carefully remove the worklight from its packaging. Examine the unit for transit damage and locate all parts. If damage is found or parts are missing, contact the transit company. Do not use damaged or broken parts. The ease of wiring access should be taken into consideration in the selection of the mounting location.

### EW3100 Series Rear Mounting:

1. Insert the two smaller hex head bolts into the rear channel of the bar. Loosely secure the brackets to the rear of the bar with as shown in FIGURE 1.
2. Position the bar in the desired mounting location. Slide the rear mounting brackets into place ensuring there is at least half the total length of the bar between them, i.e., 16" apart minimum for a 32" bar. Mark and drill two 0.332" diameter holes using a Q sized drill bit for the two larger hex head bolts. Secure the rear mount brackets in place on the vehicle using the included larger nylon insert nuts.
3. Tighten the smaller nylon insert nuts to secure the bar at the desired angle.

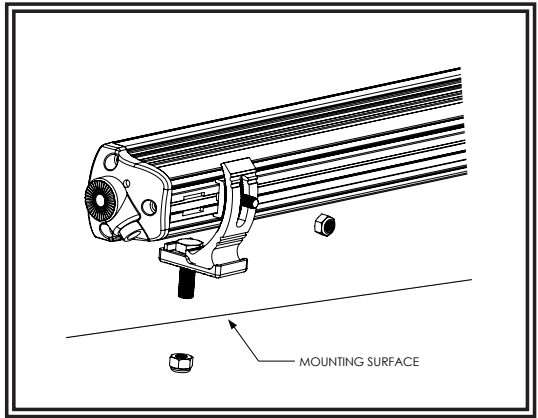

Figure 1

### EW3200 Series Rear Mounting:

1. Insert a hex head bolt through each rear mount bracket and loosely secure the brackets to the rear of the bar with the button head bolts as shown in FIGURE 2.
2. Position the bar in the desired mounting location. Slide the rear mounting brackets into place ensuring there is at least half the total length of the bar between them, i.e., 16" apart minimum for a 32" bar. Mark and drill two 0.332" diameter holes using a Q sized drill bit for the two hex head bolts. Secure the rear mount brackets in place on the vehicle using the included nylon insert nuts.
3. Tighten the button head bolts to secure the bar at the desired angle.

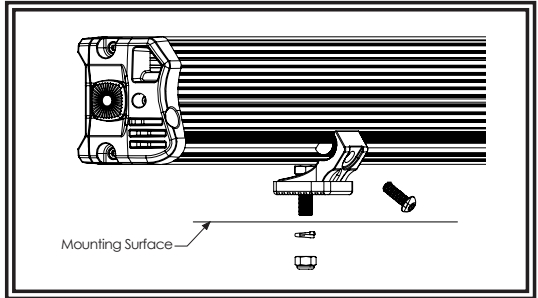

Figure 2

### End Mounting:

1. Loosely secure the brackets to the ends of the bar as shown in FIGURE 3.
2. Position the bar in the desired mounting location. Mark and drill two holes that match the size and position of the mounting brackets. Secure the brackets in place on the vehicle using the included hardware.
3. Tighten the socket head screws at each end to secure the bar at the desired angle.

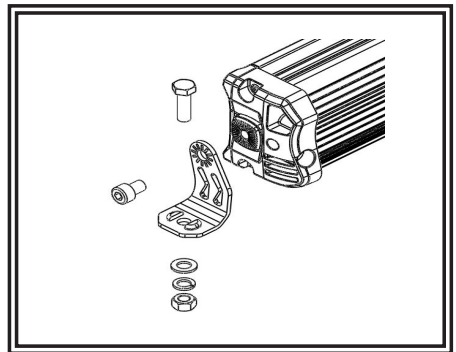

Figure 3

### Wiring Instructions:

#### Notes:

1. Larger wires and tight connections will provide longer service life for components. For high current wires it is highly recommended that terminal blocks or soldered connections be used with shrink tubing to protect the connections. Do not use insulation displacement connectors (e.g., 3M Scotchlok type connectors). Route wiring using grommets and sealant when passing through compartment walls. Minimize the number of splices to reduce voltage drop.
2. High ambient temperatures (e.g., under-hood) will significantly reduce the current carrying capacity of wires, fuses, and circuit breakers. All wiring should conform to the minimum wire size and other recommendations of the manufacturer and be protected from moving parts and hot surfaces. Looms, grommets, cable ties, and similar installation hardware should be used to anchor and protect all wiring.
3. Fuses or circuit breakers should be located as close to the power takeoff points as possible and properly sized to protect the wiring and devices.
4. Particular attention should be paid to the location and method of making electrical connections and splices to protect these points from corrosion and loss of conductivity.
5. Ground termination should only be made to substantial chassis components, preferably, directly to the vehicle battery.
6. Circuit breakers are very sensitive to high temperatures and will "false trip" when mounted in hot environments or operated close to their capacity.

Wire as shown in FIGURE 4. All wiring should be a minimum of 18 AWG. The positive line must have a slow blow 8 amp fuse. Routing the ground wire directly back to negative battery terminal is recommended. Pack dielectric grease, such as Dow Corning 4, around each electric connection exposed to moisture or the ambient environment.

**Important!** Disable power before wiring the bar.

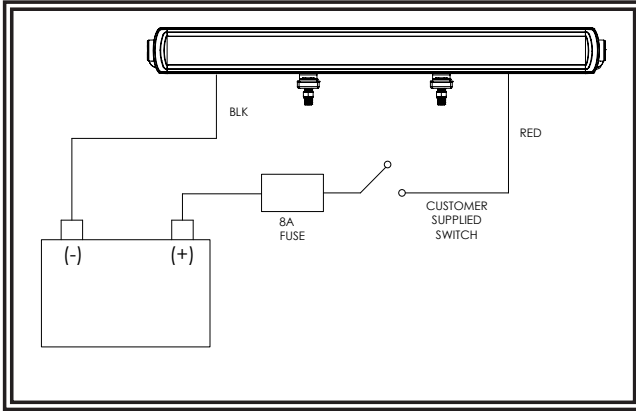

Figure 4

