



# ENGINE COMPONENTS

## NEW UNIVERSAL ENGINE CASE (MAGNESIUM ALLOY) AS41

Our new universal, dual relief Engine Case is the latest AS41 version and features a medium oil pick-up tube. For stock 1500-1600cc replacement, or can be modified for hi-performance and racing applications. Uses Metal Cam Plug 113-101-157C or Aluminum Cam Plug with O-Ring P/N 16-9524.



- Magnesium Alloy Cases Weigh Approximately 25lbs
- 8mm Steel Case Savers
- Includes Oil Pick-Up Tube

**98-0431-B** New Engine Case  
(Ref. P/N: 043 101 025)  
(Ref. P/N: 043 101 102A)  
(Ref. P/N: 043 101 033)

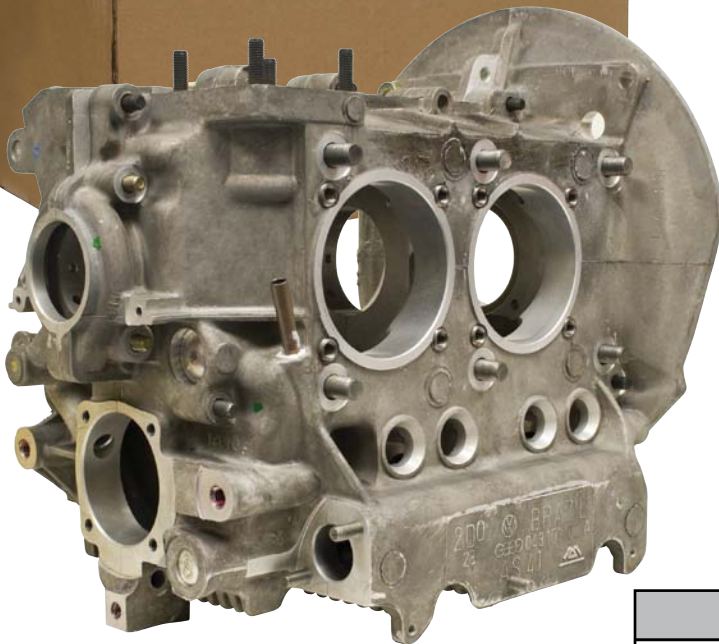

Deck Volume Table (CC's)						
Deck Height	Piston Size			Deck Height In CC's		
	85.5	87	88	90.5	92	94
.030"	4.36	4.51	4.62	4.88	5.04	5.27
.035"	5.16	5.34	5.47	5.78	5.97	6.24
.040"	5.79	6	6.13	6.49	6.71	7
.045"	6.71	6.54	7.11	7.52	7.77	8.11
.050"	7.28	6.95	7.72	8.16	8.43	8.8
.055"	8.03	8.31	8.51	9	9.3	9.71
.060"	8.72	9.03	9.24	9.77	10.09	10.54
.065"	9.46	9.8	10.03	10.6	10.96	11.44
.070"	10.15	10.51	10.75	11.37	11.76	12.27
.075"	10.9	11.28	11.55	12.21	12.62	13.17
.080"	11.64	12.06	12.34	13.05	13.48	14.08
.085"	12.33	12.77	13.06	13.82	14.28	14.91

Engine Displacement Table						
Bore	Stroke		Engine Displacement In CC's			
	64	69	74	76	78.4	82
77	1192*	1286**	1378	1415	1460	1527
83	1385	1493+	1601	1644	1696	1774
85.5	1496	1584++	1699	1745	1800	1882
87	1521	1641	1759	1806	1863	1949
88	1556	1679	1799	1848	1906	1994
90.5	1646	1776	1903	1955	2016	2110
92	1700	1835	1967	2020	2084	2180
94	1776	1915	2052	2109	2175	2275

\* Stock 1200cc; \*\* Stock 1300cc; + Stock 1500cc; ++Stock 1600cc

**Bore (mm) x Bore (mm) x Stroke (mm) x .0031416 = Engine Displacement in CC's**

**Example:** 87 x 87 x 69 x .0031416 = 1641cc

**To get the volume for one (1) cylinder in CC's, simply divide by four (4).**

**Example:** 1641 ÷ 4 = 410.25cc

## EMPI H.D. BUBBLE TOP ENGINE CASES

EMPI engine cases are all new construction with numerous design features added in right from the start. All cases are made from high quality aluminum alloy and are fully CNC machined following strict quality control standards.

Part#	Brand	Style	Material	Shuffle Pins	Crank Clearance	Full Flow	Sand Seal	Cyl. Size	Case Studs Size
98-0451-B	Autolinea	Bubble Top	Aluminum	No	+	No	No	85.5	8mm
98-0471-B	Autolinea	Bubble Top	Aluminum	Yes*	86mm	Yes	Yes	85.5	8mm
98-0453-B	Autolinea	Bubble Top	Aluminum	Yes	86mm	Yes	No	90.5/92mm	8mm
98-0465-B	Autolinea	Bubble Top	Aluminum	Yes	86mm	Yes	Yes	90.5/92mm	8mm
98-0463-B	Autolinea	Bubble Top	Aluminum	Yes	86mm	Yes	No	90.5/92mm	10mm
98-0466-B	Autolinea	Bubble Top	Aluminum	Yes	86mm	Yes	Yes	90.5/92mm	10mm
98-0454-B	Autolinea	Bubble Top	Aluminum	Yes	86mm	Yes	No	94mm	8mm
98-0467-B	Autolinea	Bubble Top	Aluminum	Yes	86mm	Yes	Yes	94mm	8mm
98-0464-B	Autolinea	Bubble Top	Aluminum	Yes	86mm	Yes	No	94mm	10mm
98-0468-B	Autolinea	Bubble Top	Aluminum	Yes	86mm	Yes	Yes	94mm	10mm

\* Center Main Only

+ May Require Clearancing for Certain Rods

### These Cases Feature:

- These cases weigh approximately 41 to 44 lbs.
- Made from high quality Aluminum with numerous design features.
- Dual Relief Design for Type 1, 2 or 3 applications.
- Shuffle Pins (6) on all main saddles for a snug fit, zero gap and longevity.
- Bubble Top / Raised Roof Design with a strong radius design adding strength and allowing additional clearance for up to an 86mm Crank.
- Ported and smoothed for better flow.
- Filled in (not welded) support behind #3 cylinder.
- Available Drilled & Tapped for Full Flow – w/plugs supplied.
- Main Oil Gallery tapped for ease of cleaning.
- Large Oil pick-up tube.
- Available machined for Sand Seal.
- Available in 3 Bore Sizes and for 8mm or 10mm Studs.
- Modification to Fan Housing Required.
- Uses Metal Cam Plug 113-101-157C or Aluminum Cam Plug with O-Ring P/N 16-9524.

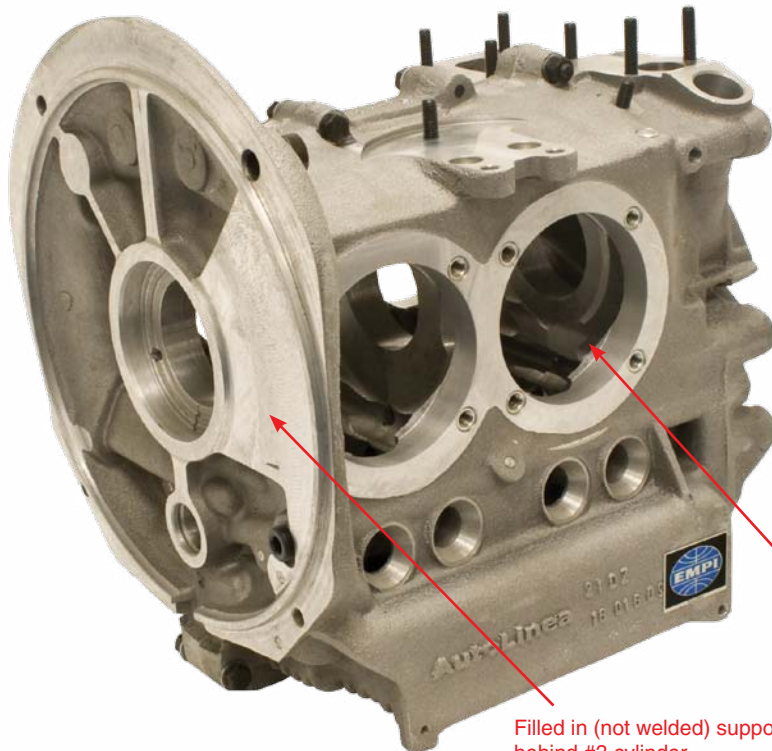

Available in 3 Bore Sizes and for 8mm or 10mm Studs.

Filled in (not welded) support behind #3 cylinder.



# ENGINE COMPONENTS

## EMPI H.D. BUBBLE TOP ENGINE CASES

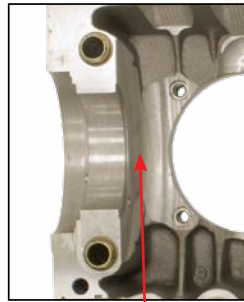

Filled in solid and then  
Clearanced for 86mm Crank

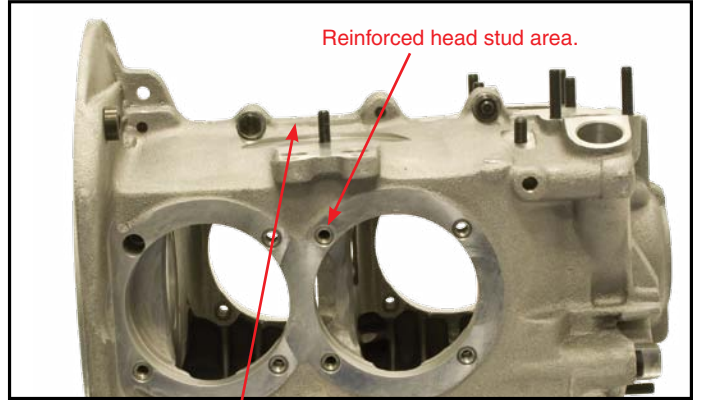

Reinforced head stud area.

Bubble Top / Raised Roof Design with a strong radius design  
adding strength and allowing additional clearance for up to an  
86mm Crank.

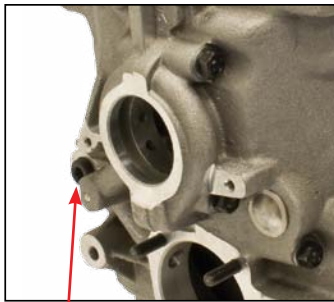

Drilled and tapped for full flow.

Available with 6 Shuffle  
Pins for a snug fit, zero  
gap and longevity.

Ported and Smoothed for  
better flow.

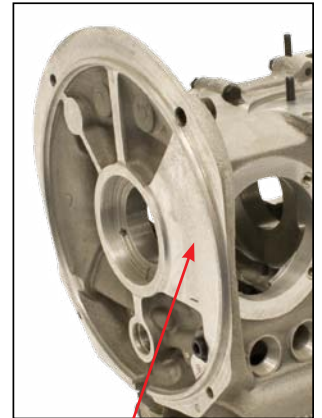

Filled in (not welded) support  
behind #3 cylinder.

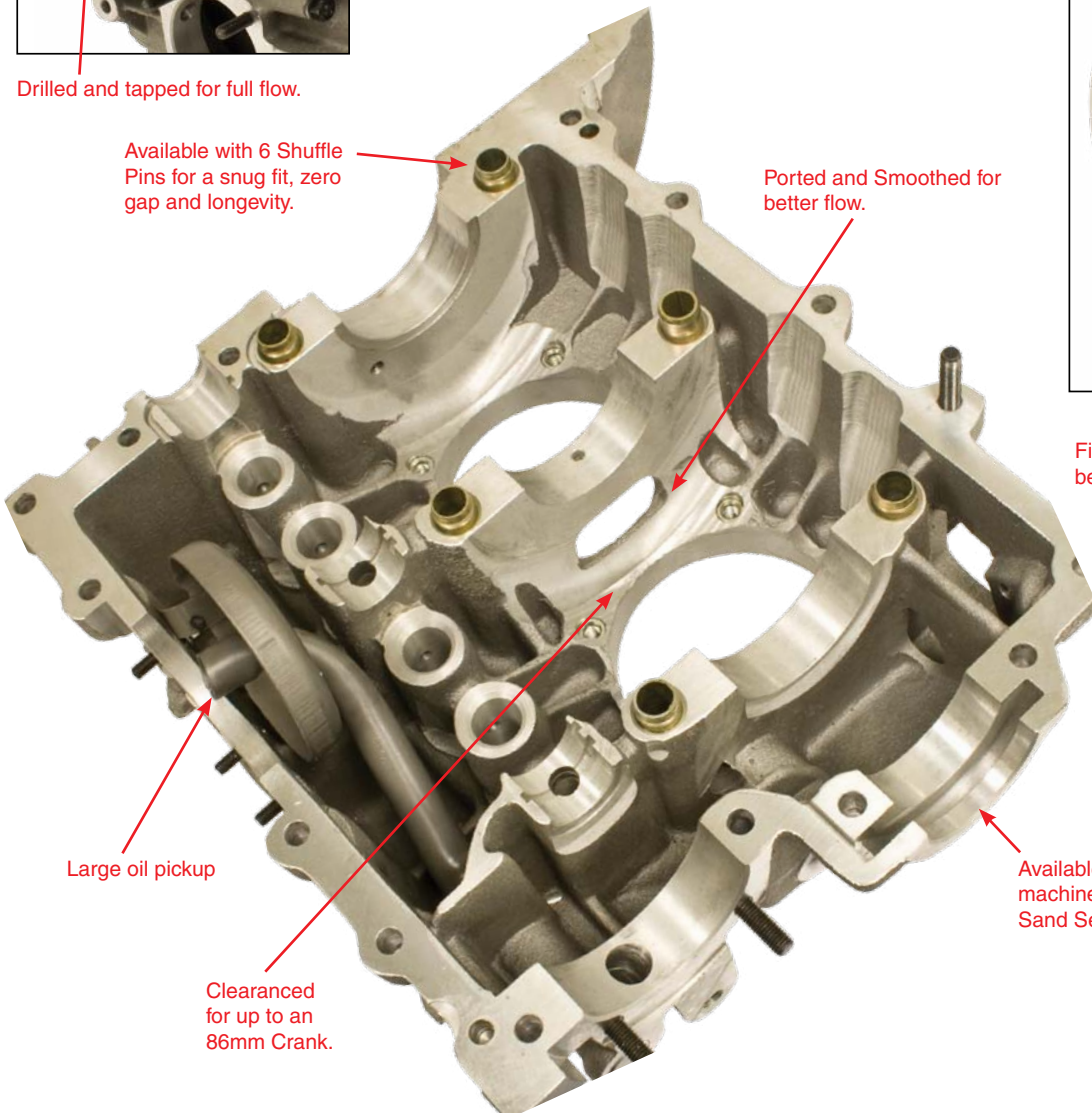

Large oil pickup

Clearanced  
for up to an  
86mm Crank.

Available  
machined for  
Sand Seal.



## CHROMOLY CASE STUDS

EMPI's Chromoly Case Studs provide superior and even clamping force required by today's hi-performance VW engines. Our Chromoly Studs are made from high-grade Chromoly and precision machined to resist stretch and fatigue. EMPI Chromoly Case Studs are available with 8mm or 10mm threads, stock length or +1/2" longer for stroker applications or other variables. Each kit is complete with O.E. style hardened washers and hex nuts.

**4020** Stock Length 8mm Chromoly Case Stud Kit, for Dual Port Heads

(Ref. P/N: 043 198 035DP)

**4021** +1/2" Longer 8mm Chromoly Case Stud Kit, for Dual Port Heads

**4009** Stock Length 10mm Chromoly Case Stud Kit, for Dual Port Heads

**4010** +1/2" Longer 10mm Chromoly Case Stud Kit, for Dual Port Heads

**4005** Stock Length 8mm Chromoly Case Stud Kit, for Single Port Heads

(Ref. P/N: 043 198 035SP)

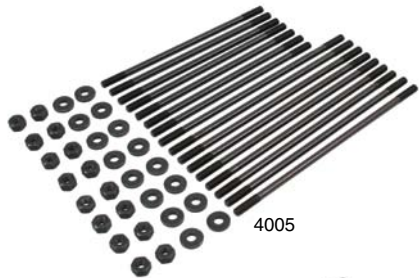

## SELF TAPPING CASE STUDS

A quick repair for stripped head studs. The rolled threads of our 10mm studs provide maximum hold and metal chips are effectively collected by the slot and hole design. Sold in Bulk Per Stud.

**4025** 1500-1600cc, Lower, 9 3/8" (240mm), Each

## BILLET CAM PLUG WITH O-RING

Use this Billet cam plug during engine assembly for a secure, leak free seal. Case must be machined for O-Ring groove.

**16-9524** Billet Cam Plug with O-Ring



## CAM PLUG

Always use a new Cam Plug to ensure a leak free seal.

**98-0156** Cam Plug, Metal, for Case w/Groove, 1300-1600cc (Bulk P/N: 113 101 157C)

**98-0157** Cam Plug, Rubber, for O.E. Case w/o Groove (Bulk P/N: 040 101 157)



98-0156



98-0157

## MAIN BEARING DOWEL PIN SET (5)

Set of 5 standard length main bearing dowel pins for engine assembly.

**16-9519** Main Bearing Dowel Pin Set (5) (Bulk P/N: 111 101 123)





# ENGINE COMPONENTS

## ENGINE LOCK NUT KIT

Don't let a bunch of old rusty nuts ruin the appearance of your next engine rebuild. Bright zinc nylock nuts resist vibration, maintain torque and prevent oil seepage even in the roughest conditions.

9521 Engine Lock Nut Kit



## DELUXE ENGINE HARDWARE KIT

You get all the necessary hardware you need to assemble your engine just the way it rolled off the assembly line.

4018 Deluxe Engine Hardware Kit, 8mm  
4019 Deluxe Engine Hardware Kit, 10mm



## ENGINE HARDWARE KITS

All the bolts, nuts and washers required for the assembly of the engine.

9523 Complete Engine Hardware Kit, 10mm

9524 Shroud Screw Kit, 12 Pcs.

9524-B Bulk Shroud Screws, Bag of 100  
(Ref. P/N: N 10 710 8)

43-6051 Brass 8mm-1.25 thread, 11mm Head,  
Int./Exh. Nuts, Set of 8

43-6051-B Bulk Brass 8mm-1.25 thread, 11mm Head,  
Int./Exh. Nuts, Bag of 100



B250520 **NEW!** HD Racing Exhaust Nuts, Steel Plated, Set of 8  
8mm-1.25 Thread, 11mm Head



9525 Exhaust Lock Nut Set, Copper, 8pcs.  
9525-B Bulk Exh. Lock Nuts, Copper, Bag of 100  
(Ref. P/N: 175 129 650)



17-2988 **NEW!** 12 Point 8mm Engine Nuts, 8 pcs  
8mm-1.25 Thread, uses 10mm 12 Point Socket





## **OIL DIPSTICK ADAPTER**

Converts Type 3 and universal cases which have not been machined for a dipstick tube.

**8932** Oil Dipstick Adapter w/Gasket



## **TYPE 3 BLOCK-OFF KIT**

Use on late style and Type 3 cases to block off oil fill opening to convert to upright applications. Complete with cast aluminum block-off plate and gasket.

**8931** T-3 Block-Off Kit  
**16-9516** Billet T-3 Block-Off Kit



## **TYPE 3 BLOCK-OFF PLATE**

Complete with thick metal block-off plate and gasket.

**98-1170** Block-Off Plate, Dipstick Hole, Type 3  
**98-1171** Block-Off Plate, Dipstick Hole with 1/8" NPT Tapped Hole



## **STOCK DIPSTICK**

Stock Replacement Dipstick.

**113 115 611** **98-1162-B** Stock Dipstick, 1200-1600cc



## **CHROME DIPSTICKS**

Two versions are available: Stock length and/or Stock plus 7 1/2" length. Longer length helps protect hands from burns on engines with custom exhaust systems. All EMPI dipsticks are designed to fit both stock and aftermarket engine cases.

**9054** Chrome Dipstick, Stock Length  
**9075** Chrome Dipstick, 7 1/2" Longer



## **BILLET STYLE DIPSTICK**

Stock length dipstick with machined aluminum Billet style handle.

**8500** Billet Style Dipstick

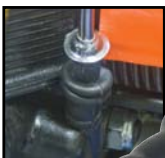

## **DIPSTICK BOOT**

This boot was designed for late model Buses, but is really a universal fit. Install on your Type 1 engine case with stock or aftermarket dipstick. Keeps the oil in...and the dirt out!

**98-9610** Dipstick Boot, Universal, Each  
 (Bulk P/N: 021 119 245)



# ENGINE COMPONENTS

## HEX HEAD OIL RELIEF SPRING PLUG, PR.

A long overdue solution to the removal and replacement of relief plugs. These threaded steel hex head plugs eliminate the need for that giant screwdriver.

16-9527 Hex Head Oil Relief Spring Plug, Pr.



## FUEL PUMP BLOCK-OFF / MOUNT

Two versions available to suit your specific needs. Block off with 12mm threaded breather boss. Block off in high tech polished Billet aluminum. All include mounting gasket.

9094 Fuel Pump Block-Off w/Boss

31-3011 Billet Fuel Pump Block-Off w/Hardware



## ELECTRIC FUEL PUMP MOUNT KIT

Allows for the installation of EMPI or Facet electric fuel pumps in the stock pump location. Hardware and gasket included.

31-3010 Electric Fuel Pump Mount Kit



## BILLET COMBO FUEL PUMP BLOCK-OFF / COIL MOUNT

Polished aluminum Combo Mount serves as a fuel pump block-off, breather vent and ignition coil holder. Features a 3/8 NPT outlet for vent. Great looking and functional. Hardware and gasket included.

17-2926 Billet Combo Fuel Pump Block-Off / Coil Mount



## BILLET FUEL PUMP BLOCK-OFF w/ VENT

Polished aluminum Fuel Block-Off features a 3/8 NPT outlet for vent. Hardware and gasket included.

17-2927 Billet Fuel Pump Block-Off



**Forged**



8180

## EMPI 4340 CHROMOLY STROKER CRANKS

EMPI has developed this high quality counter-weighted Stroker Crank with the serious racer in mind. Multiple die stamp forged from 4340 chromoly (One of the strongest materials available for crankshafts). Cranks are then magna fluxed, shot peened and all journals are nitrided, precision ground and micro polished. Additional features include cross drilled, chamfered oil holes, dynamic balancing, 8 dowel and extra long 8mm dowel pins. Choose the journal size and stroker combination that best suits your application.

<b>8180</b>	76 Stroke Counter-weighted Crankshaft, VW Journals
<b>8181</b>	78 Stroke Counter-weighted Crankshaft, VW Journals
<b>8182</b>	82 Stroke Counter-weighted Crankshaft, VW Journals
<b>8185</b>	76 Stroke Counter-weighted Crankshaft, Chevy Journals
<b>8186</b>	78 Stroke Counter-weighted Crankshaft, Chevy Journals
<b>8187</b>	82 Stroke Counter-weighted Crankshaft, Chevy Journals
<b>8188</b>	84 Stroke Counter-weighted Crankshaft, Chevy Journals

**Note: Stroker Cranks require machining of case and possibly other internal components for rod clearance.**

**Forged**

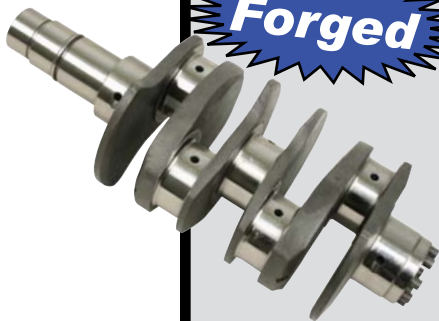

8121

## EMPI 4140 CHROMOLY CRANKSHAFTS

The heart of any hi-performance engine is the crankshaft. Counter-weighted crankshafts greatly reduce power robbing and damaging crank-flex, high RPM harmonics and vibration through the entire power range. EMPI's Counter-weighted Crankshafts are perfect for the racer on a budget. These cranks are precision ground, micro-polished, nitrided and balanced. Features include: forged from 4140 chromoly, radiused standard/standard journals, chamfered oil holes, 8 dowel, 8mm dowel pins and cross-drilled. Available in stock 69mm stroke or 74mm stroker versions. Both use stock VW main and rod bearings.

<b>8120</b>	69mm Counter-weighted Crankshaft
<b>8121</b>	74mm Counter-weighted Crankshaft

## NEW DIRECT DRILLED CRANKSHAFT

In cross-drilled crankshafts the pressure is divided in two directions, creating a zone of turbulence causing effects similar to oil foaming that reduces constant lubrication. **DIRECT DRILLED** Crankshafts force the oil in one direction for better full flow lubrication. 4 dowel, with dowel pins. These cast Cranks are New Standard/Standard with stock 69mm stroke.



<b>043 105 101</b>	<b>98-1510-B</b>	69mm Direct Drilled Cast Crankshaft
--------------------	------------------	-------------------------------------





## COMPETITION LENGTH CRANKSHAFT DOWEL PINS

These longer length dowel pins fit deeper into the crankshaft to protect against shearing under high twist loads. Available with stock 8mm diameter or 11/32" if your crankshaft has elongated holes. Crankshaft may have to be drilled deeper to accept longer dowel pins. **Both of these dowel pins are 19mm long.** Sold in sets of 8.



8141



8142

- 8140**                    8mm Competition Dowel Pin, Set of 8
- 8141**                    11/32" Competition Dowel Pin, Set of 8
- 8142**                    8 Hole Paper Gasket, 8mm Holes, Pack of 10
  
- 5004**                    Crankshaft & Flywheel Drill Fixture (8mm)



5004

## CRANKSHAFT INSTALLATION KIT

Includes new timing gear, distributor drive gear, distributor drive pinion, oil slinger, retaining clip and woodruff keys. Fits 1200-1600cc. (7 pc. Kit). See pages 429-437 for tools.

- 8105**                    Crankshaft Installation Kit, 1200-1600cc (7 pcs.)
  
- 113 105 209**            **98-1520-B** Timing Gear, 1200-1600cc
- 111 105 223**            **98-1523-B** Distributor Drive Gear, 1200-1600cc
- 113 105 231B**        **98-1531-B** Distributor Drive Pinion, 1200-1600cc
- 113 105 241A**        **98-1541-B** Oil Slinger, 1200-1600cc
- 111 105 227**            **98-1527-B** Retaining Clip, 1200-1600cc
- 111 105 213**            **98-1521-B** Woodruff Key, Timing Gear, 1200-1600cc
- 113 105 249**            **98-1549-B** Woodruff Key, Crank Pulley, 1200-1600cc
  
- 111 105 233**            **98-0115-B** Distributor Drive Pinion Spring, Type 1 61-79, Ghia 61-74, Type 2 61-71, Type 3 64-73, Each Not in Kit P/N 8105



113 105 209



111 105 223



113 105 231B



111 105 233



113 105 241A



111 105 227



111 105 213



113 105 249

## PERFORMANCE CRANKSHAFT GEAR SPACER

Gear spacer failure can be a costly event. The stock spacer was never intended to survive the stress of today's high output engines. Our Performance Spacer replaces the stock unit with a solid ring of safety for your gear train.

- 16-9522**                    Performance Crankshaft Gear Spacer





## EMPI FORGED 4340 CHROMOLY H-BEAM RODS

EMPI's H-Beam Rods are a must if you are planning on building an all out performance engine. Race proven H-Beam design combines weight savings and high strength thanks to the forged 4340 chromoly construction. Radiused rod caps help reduce the amount of clearancing required on stroker applications and are sleeved to the rod to eliminate cap shifting. Precision machined rods are magna fluxed and sold in matched weight sets of 4. All held together with forged ARP 5/16" bolts capable of withstanding 220,000 psi tensile load. EMPI's H-Beam Rods are the perfect match to our stroker cranks. (Torque to 26 ft. lbs.) (Sets of 4).

- 8310 H-Beam Rods, 5.400" Length, VW Journal 2.165"/55mm (ARP Bolts)
- 8311 H-Beam Rods, 5.500" Length, VW Journal 2.165"/55mm (ARP Bolts)
- 8312 H-Beam Rods, 5.600" Length, VW Journal 2.165"/55mm (ARP Bolts)

---

- 8320 H-Beam Rods, 5.400" Length, Chevy Journal 2.000"/51mm (ARP Bolts)
- 8321 H-Beam Rods, 5.500" Length, Chevy Journal 2.000"/51mm (ARP Bolts)
- 8323 H-Beam Rods, 5.700" Length, Chevy Journal 2.000"/51mm (ARP Bolts)

- 8303 Chevy Journal Rod Bearings, .020 (Mahle Brazil)
- 8304 Chevy Journal Rod Bearings, .030 (Mahle Brazil)

- 8308 ARP 2000 H-Beam 5/16" Rod Bolts, 220,000 psi tensile load, Set of 8
- 8309 EMPI H-Beam 5/16" Rod Bolts Only, Set of 8
- 8310-6 Bushing for H-Beam Rods, Ea

## ROD BEARINGS & BUSHINGS MAHLE BRAZIL

- 113 105 701 98-1575-B Rod Bearing Set, Std., 1200-1600cc
- 113 105 707 98-1577-B Rod Bearing Set, .25mm, 1200-1600cc
- 113 105 713 98-1571-B Rod Bearing Set, .50mm, 1200-1600cc
- 113 105 719 98-1579-B Rod Bearing Set, .75mm, 1200-1600cc
- 311 105 431A 98-1570-B Rod Bushing Set, Set of 4



## CHEV ROD BEARINGS MAHLE / CLEVITE USA

- 98-1599-C **NEW!** Chev Rod Bearings, Std.
- 98-1600-C **NEW!** Chev Rod Bearings, .25mm
- 98-1601-C **NEW!** Chev Rod Bearings, .50mm
- 98-1602-C **NEW!** Chev Rod Bearings, .75mm



98-1599-C

## EMPI FORGED 4140 CHROMOLY I-BEAM RODS

EMPI's I-Beam Rods use the O.E. design, but are forged from 4140 chromoly to give you a high strength rod that's easy on your budget. 3/8" 8740 200,000 psi tensile load rod bolts add all the strength and reliability necessary for this rod design. Radiused caps aid in stroker clearancing. Combine with an EMPI counter weighted crank to build a dependable lower end for moderate performance engines. All rods are sold in matched weight. Torque these 3/8" bolts to 38 ft. lbs. Sets of 4.

- 8340 I-Beam Rod, 5.394", VW Journal 2.165"/55mm (EMPI 3/8" Rod Bolts), Set of 4
- 8351 I-Beam Rod, 5.500", Chevy Journal 2.000"/51mm (EMPI 3/8" Rod Bolts), Set of 4
- 8355 ARP 8740 3/8" I-Beam Rod Bolts Only, Set of 8

## NEW FORGED STOCK REPLACEMENT CONNECTING RODS

Connecting Rods are the vital link between the piston and crank. Don't take a chance by using worn rods in your engine. EMPI offers **Brand New** units made to factory specifications. Torque these rod bolts to 24ft lbs.

- 311 105 401B 98-0153-B New Connecting Rods, 1300-1600cc, Set of 4



8310



8308



98-1571-B

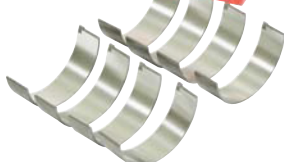

8340

All New  
Not Reconditioned





# ENGINE COMPONENTS

## EMPI CHROMOLY RACING FLYWHEEL

This chromoly version of our lightened flywheel is the answer for anyone looking for the ultimate in durability under extreme conditions. One piece chromoly construction and offset 8-dowel hole pattern along with a weight of approximately 13 lbs., make this fully balanced flywheel the best option for a high performance engine. 12-Volt 200mm (130 teeth) O-ring style.

**4099** Chromoly Flywheel, 12-Volt, 200mm, (Boxed)



## NEW FLYWHEELS

Worn-out and defective flywheels can cause a host of problems, from leaking crankshaft seals to broken starter drive gears to clutch chatter and failure. Our flywheels are manufactured to exacting specifications from high grade steel and balanced. The lightweight version is drilled for 8 dowel pins and lightened to approximately 13 lbs. Both are 200mm 12-Volt (130 teeth) O-ring style. Fits Type 1/2/3 1300-1600cc.

**311 105 273A** **98-1273-B** Flywheel, Stock Style, 4 Dowel Pin, 200mm (Boxed)

**311 105 273HP** **98-1275-B** Flywheel, Lightened, 8 Dowel Pin (Boxed)



98-1275-B

## EMPI HI-PERFORMANCE CHROMOLY GLAND NUT

Don't take a chance on stock gland nuts in high performance applications. This ultra strong bad boy is made from 4130 chromoly. The extra strength chromoly and concave spring steel washer provide maximum holding power. Fitted with special pre-greased needle bearing and grease seal. Compatible with stock 4 dowel pin and 8 dowel pin flywheels and features a 36mm nut size.

**4026** Chromoly Gland Nut w/Washer



36mm size

## CHROMOLY GLAND NUT & WASHER

Our Heavy Duty Gland Nut set includes an O.E.M. type gland nut and heavy duty washer for extra load capacity and increased torque capabilities. Provides the perfect upgrade for most high performance and all stock applications.

**4029** Chromoly Gland Nut & Washer Kit

**4029-B** Bulk Chromoly Gland Nut Only, Each

(Ref. P/N: 111 105 305E)

**4030** H.D. Washer Only, Each

**4030-B** Bulk H.D. Washer Only, Each

(Ref. P/N: 111 105 297)



36mm size

4029

## FLYWHEEL SEALS

EMPI's High Quality Silicone Flywheel Seal provides outstanding sealing qualities in the most severe conditions. Resistant to failure due to extreme temperature.

**32-1545** Red Silicone Flywheel Seal, Each

(Bulk P/N : 113 105 245FS)

**32-1546** Red Silicone Flywheel Seal, Each (Elring)

(Bulk P/N: 113 105 245FG)

**98-0150-B** Flywheel Seal, 1.7-2.0L, Type 4 Engines

(Ref. P/N: 029 105 245B)

**98-1283-B** O-Ring, Flywheel, Type 1 66-79, Ghia 67-74,

Type 2 64-71, Type 3 64-73, Each

(Ref. P/N: 311 105 295A)



32-1545



98-1283-B

## SILVERLINE STEEL BACK MAIN BEARINGS

Manufactured in Mexico by Silverline - an Original Equipment Supplier. Top engine builders will tell you that all aluminum center main bearings can cause increased bearing wear or premature failure and will eventually pound-out the center main web of the engine case due to the bearing's softer construction. The cure...new Silverline Engine bearings - with **STEEL** Backing and an Aluminum Face. OEM Quality Main Bearings with **STEEL** Backing. Available in sizes to fit most case and crank combinations.

## MAIN BEARINGS



Sizes listed are in Metric, US equivalent measurements are:

.25mm = .010"	1.00mm = .040"
.50mm = .020"	1.50mm = .060"
.75mm = .030"	2.00mm = .080"



### STANDARD CASE/MACHINED CRANKS

111 198 461MX	98-1461-S	Main Brg. Set, Std./Std., 1200-1600cc
111 198 463MX	98-1463-S	Main Brg. Set, Std./25mm, 1200-1600cc
111 198 465MX	98-1465-S	Main Brg. Set, Std./50mm, 1200-1600cc
111 198 467MX	98-1467-S	Main Brg. Set, Std./75mm, 1200-1600cc
021 198 481AMX	98-1451-S	Main Brg. Set, Std./Std., 1.7-2.0L Type 4
021 198 483AMX	98-1452-S	Main Brg. Set, Std./25mm, 1.7-2.0L Type 4
021 198 485AMX	98-1593-S	Main Brg. Set, Std./50mm, 1.7-2.0L Type 4

### LINE BORED CASE/STANDARD CRANK

111 198 471MX	98-1471-S	Main Brg. Set, .50mm/Std., 1200-1600cc
111 198 481MX	98-1481-S	Main Brg. Set, 1.00mm/Std., 1200-1600cc

### LINE BORED CASE/MACHINED CRANK

111 198 473MX	98-1473-S	Main Brg. Set, .50mm/.25mm, 1200-1600cc
111 198 475MX	98-1475-S	Main Brg. Set, .50mm/.50mm, 1200-1600cc
111 198 477MX	98-1477-S	Main Brg. Set, .50mm/.75mm, 1200-1600cc
111 198 479MX	98-1479-S	Main Brg. Set, .50mm/1.00mm, 1200-1600cc
111 198 483MX	98-1483-S	Main Brg. Set, 1.00mm/.25mm, 1200-1600cc
111 198 485MX	98-1485-S	Main Brg. Set, 1.00mm/.50mm, 1200-1600cc
111 198 487MX	98-1587-S	Main Brg. Set, 1.00mm/.75mm, 1200-1600cc

### LINE BORED CASE/STANDARD CRANK, W/1.00MM O/S THRUST

111 198 471OSMX	98-1710-S	Main Brg. Set, .50mm/Std./1.00mm, 1200-1600cc
111 198 481OSMX	98-1810-S	Main Brg. Set, 1.00mm/Std./1.00mm, 1200-1600cc

### LINE BORED CASE/MACHINED CRANK, W/1.00MM O/S THRUST

111 198 473OSMX	98-1740-S	Main Brg. Set, .50mm/.25mm/1.00mm, 1200-1600cc
111 198 475OSMX	98-1750-S	Main Brg. Set, .50mm/.50mm/1.00mm, 1200-1600cc
111 198 477OSMX	98-1770-S	Main Brg. Set, .50mm/.75mm/1.00mm, 1200-1600cc
111 198 483OSMX	98-1830-S	Main Brg. Set, 1.00mm/.25mm/1.00mm, 1200-1600cc
111 198 485OSMX	98-1850-S	Main Brg. Set, 1.00mm/.50mm/1.00mm, 1200-1600cc
111 198 487OSMX	98-1588-S	Main Brg. Set, 1.00mm/.75mm/1.00mm, 1200-1600cc

### LINE BORED CASE/STANDARD CRANK, W/2.00MM O/S THRUST

111 198 471 02MX	98-1712-S	Main Brg. Set, .50mm/Std./2.00mm, 1200-1600cc
111 198 473 02MX	98-1589-S	Main Brg. Set, .50mm/.25mm/2.00mm, 1200-1600cc
111 198 475 02MX	98-1590-S	Main Brg. Set, .50mm/.50mm/2.00mm, 1200-1600cc
111 198 477 02MX	98-1591-S	Main Brg. Set, .50mm/.75mm/2.00mm, 1200-1600cc
111 198 481 02MX	98-1812-S	Main Brg. Set, 1.00mm/Std./2.00mm, 1200-1600cc
111 198 491 60MX	98-1496-S	Main Brg. Set, 1.50mm/Std./2.00mm, 1200-1600cc
111 198 491 80MX	98-1480-S	Main Brg. Set, 2.00mm/Std./2.00mm, 1200-1600cc

### LINE BORED CASE/MACHINED CRANK, W/2.00MM O/S THRUST

111 198 483 02MX	98-1832-S	Main Brg. Set, 1.00mm/.25mm/2.00mm, 1200-1600cc
111 198 485 02MX	98-1852-S	Main Brg. Set, 1.00mm/.50mm/2.00mm, 1200-1600cc
111 198 487 02MX	98-1592-S	Main Brg. Set, 1.00mm/.75mm/2.00mm, 1200-1600cc
111 198 493 60MX	98-1493-S	Main Brg. Set, 1.50mm/.25mm/2.00mm, 1200-1600cc
111 198 493 80MX	98-1498-S	Main Brg. Set, 2.00mm/.25mm/2.00mm, 1200-1600cc
111 198 495 60MX	98-1495-S	Main Brg. Set, 1.50mm/.50mm/2.00mm, 1200-1600cc
111 198 497 60MX	98-1596-S	Main Brg. Set, 1.50mm/.75mm/2.00mm, 1200-1600cc
111 198 495 80MX	98-1594-S	Main Brg. Set, 2.00mm/.50mm/2.00mm, 1200-1600cc
111 198 497 80MX	98-1595-S	Main Brg. Set, 2.00mm/.75mm/2.00mm, 1200-1600cc

### ROD BEARINGS

039 105 701MX	98-1582-S	Rod Brg. Set, Std., Type 4, 2000cc
039 105 707MX	98-1584-S	Rod Brg. Set, .25mm, Type 4, 2000cc
039 105 713MX	98-1585-S	Rod Brg. Set, .50mm, Type 4, 2000cc
039 105 719MX	98-1586-S	Rod Brg. Set, .75mm, Type 4, 2000cc

### CAM BEARINGS

111 198 541MX	98-1544-S	Cam Bearing Set, Std. 1300-1600cc
111 198 541HDMX	98-1543-S	Cam Bearing Set, Std. 1300-1600cc Double Thrust
021 198 541MX	<b>NEW!</b> 98-1453-S	Cam Bearing Set, Std. 1.7-2.0L Type 4



# ENGINE COMPONENTS

## MAIN, ROD AND CAM BEARINGS

Manufactured by MAHLE. Available in sizes to fit any combination of crank and case configuration.

Mahle has changed its manufacturing process and no longer produces bearings with Steel Backing. The New Main Bearing Sets feature Aluminum Backing.

Old inventory has been depleted, the "-B" part numbers have been Discontinued and you must now order using the "-A" part number.

### MAIN BEARINGS

#### STANDARD CASE/MACHINED CRANKS

111 198 461	98-1461-A	Main Brg. Set, Std./Std., 1200-1600cc
111 198 463	98-1463-A	Main Brg. Set, Std./25mm, 1200-1600cc
111 198 465	98-1465-A	Main Brg. Set, Std./50mm, 1200-1600cc
111 198 467	98-1467-A	Main Brg. Set, Std./75mm, 1200-1600cc
025 198 461	98-1459-A	Main Brg. Set, Std./Std., Vanagon 1.9L

#### LINE BORED CASE/MACHINED CRANK

111 198 475	98-1475-A	Main Brg. Set, .50mm/.50mm, 1200-1600cc
111 198 477	98-1477-A	Main Brg. Set, .50mm/.75mm, 1200-1600cc
111 198 479	98-1479-A	Main Brg. Set, .50mm/1.00mm, 1200-1600cc
111 198 483	98-1483-A	Main Brg. Set, 1.00mm/.25mm, 1200-1600cc
111 198 485	98-1485-A	Main Brg. Set, 1.00mm/.50mm, 1200-1600cc

#### LINE BORED CASE/STANDARD CRANK, W/1.00MM O/S THRUST

111 198 471OS	98-1710-A	Main Brg. Set, .50mm/Std./1.00mm, 1200-1600cc
111 198 481OS	98-1810-A	Main Brg. Set, 1.00mm/Std./1.00mm, 1200-1600cc

#### LINE BORED CASE/MACHINED CRANK, W/1.00MM O/S THRUST

111 198 477OS	98-1770-A	Main Brg. Set, .50mm/.75mm/1.00mm, 1200-1600cc
---------------	-----------	--

#### LINE BORED CASE/STANDARD CRANK, W/2.00MM O/S THRUST

111 198 471 02	98-1712-A	Main Brg. Set, .50mm/Std./2.00mm, 1200-1600cc
111 198 481 02	98-1812-A	Main Brg. Set, 1.00mm/Std./2.00mm, 1200-1600cc
111 198 491 60	98-1496-A	Main Brg. Set, 1.50mm/Std./2.00mm, 1200-1600cc

#### LINE BORED CASE/MACHINED CRANK, W/2.00MM O/S THRUST

111 198 495 60	98-1495-A	Main Brg. Set, 1.50mm/.50mm/2.00mm, 1200-1600cc
----------------	-----------	---

#### EXAMPLE

EMPI Part Number 98-1461-B with Steel Backing has been discontinued.

EMPI Part Number 98-1461-A with Aluminum Backing should be ordered.

Sizes listed are in Metric, US equivalent measurements are:

.25mm = .010"	1.00mm = .040"
.50mm = .020"	1.50mm = .060"
.75mm = .030"	2.00mm = .080"

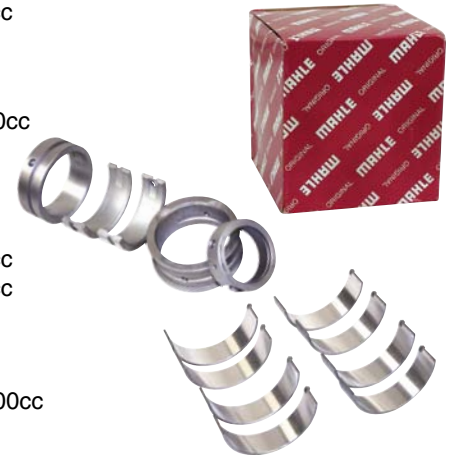

#### ROD BEARINGS & BUSHINGS MAHLE BRAZIL

113 105 701	98-1575-B	Rod Bearing Set, Std., 1200-1600cc
113 105 707	98-1577-B	Rod Bearing Set, .25mm, 1200-1600cc
113 105 713	98-1571-B	Rod Bearing Set, .50mm, 1200-1600cc
113 105 719	98-1579-B	Rod Bearing Set, .75mm, 1200-1600cc
311 105 431A	98-1570-B	Rod Bushing Set, Set of 4



#### CHEV ROD BEARINGS MAHLE / CLEVITE USA

98-1599-C	<b>NEW!</b>	Chev Rod Bearings, Std.
98-1600-C	<b>NEW!</b>	Chev Rod Bearings, .25mm
98-1601-C	<b>NEW!</b>	Chev Rod Bearings, .50mm
98-1602-C	<b>NEW!</b>	Chev Rod Bearings, .75mm

#### CAM BEARINGS

111 198 541MC	98-1544-C	Cam Bearing Set, Std. 1300-1600cc Mahle / Clevite - Mexico
021 198 541	98-1453-B	Cam Bearing Set, Std. 1.7-2.0L Type 4 Mahle - Brazil

111 198 541MC

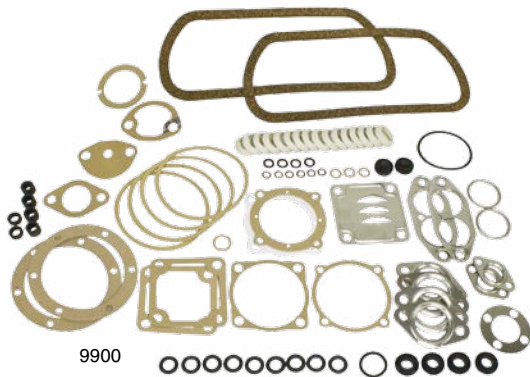



9900

## ENGINE GASKET SETS

Complete Engine Gasket Set. Includes all the gaskets and seals for the assembly of the engine. High quality valve cover gaskets are included.

**9900** Engine Gasket Set, 1300-1600cc  
(Bulk P/N: 111 198 007AF)

**9901-B**  Engine Gasket Set, 1300-1600cc (Elring)  
(Ref P/N: 111 198 007AFG)

**98-1977-B**  Engine Gasket Set, 2.0L (Elring)  
(Ref P/N: 029 198 009)



32-1545

32-1546

98-0150-B

98-1283-B

## FLYWHEEL SEALS

EMPI's High Quality Silicone Flywheel Seal provides outstanding sealing qualities in the most severe conditions. Resistant to failure due to extreme temperature.

**32-1545** Red Silicone Flywheel Seal, Each  
(Bulk P/N : 113 105 245FS)

**32-1546** Red Silicone Flywheel Seal, Each (Elring)  
(Bulk P/N: 113 105 245FG)

**98-0150-B** Flywheel Seal, 1.7-2.0L, Type 4 Engines  
(Ref. P/N: 029 105 245B)

**98-1283-B** O-Ring, Flywheel, Type 1 66-79, Ghia 67-74,  
Type 2 64-71, Type 3 64-73, Each  
(Ref. P/N: 311 105 295A)



## THREADED OIL GALLEY PLUG KIT

The first step to any quality engine build. By installing this 12 piece Oil Galley Plug Kit, you will realize the advantages and ease of cleaning and inspecting the "life blood" passages of your oiling system. Each kit contains seven 1/8" NPT, two 1/4" NPT, and three 3/8" NPT threaded aluminum plugs. Machining of case required.

**16-9515** Oil Galley Plug Set, 12 pc.

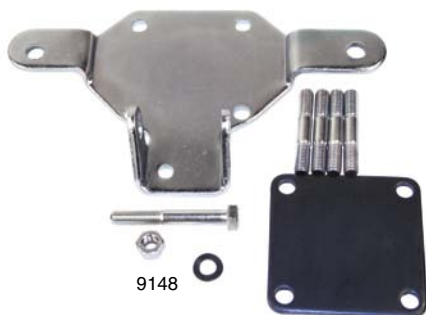

9148

## ENGINE CASE ADAPTER FOR TYPE 2 & 3

Allows the installation of the Type 1 case without the 3 point mount bosses into Type 2 & 3's with 1500-1600cc engines. Easy bolt-on installation. Complete with pump cover and all hardware.

**9148** Engine Case Adapter Kit  
**9148-7** Replacement 8mm Pump Cover only, Each  
(Bulk P/N: 311 115 141C)



# ENGINE COMPONENTS

## EMPI HI-PERF. ALUMINUM DEGREE PULLEYS

The Ultimate Aluminum Degree Pulleys. Hard anodized black for maximum durability plus Laser Engraved degree numbers and marks. Available in standard size diameter, bolt-in and machined case sand seal versions. Bolt-In versions come with P/N: 8695 collar & seal. Machine-In versions come with P/N: 8694 seal only.

### STOCK DIAMETER PULLEYS

- 33-1055 Laser Pulley, Stock Installation
- 33-1060 Laser Sand Seal Pulley, Machine-In
- 33-1065 Laser Sand Seal Pulley, Bolt-In

- 8695 Replacement Seal & Collar for Bolt-In
- 8694 Replacement Seal for Bolt-In & Machine-In



## EMPI HI-PERFORMANCE STEEL BILLET DEGREE PULLEYS

EMPI now has available Steel Billet pulleys. Featuring approximately 3 1/2 lbs. in a stock size form. These pulleys have the ability to reduce crankshaft vibration, thus resulting in much longer engine case and bearing life. All pulleys are fully balanced and feature a silver zinc finish with durable bright white timing marks and numbers on a black background. 33-1090 uses the P/N: 9117 Bolt and Washer (Sold Separately).

### STOCK DIAMETER PULLEYS

- 33-1090 Billet Steel Pulley, Stock Installation,



## EMPI 5 1/2 LB. CRANKSHAFT PULLEY

Use this heavy pulley to add weight to the rear of your crankshaft to help relieve harmonics and increase bearing and crankshaft life. Degree ring installed. Pulley uses P/N: 9118 Bolt and Washer (Sold Separately).

- 16-9701 5 1/2 lbs. Crankshaft Pulley, Stock Size, Machined for Sand Seal, Each [Order Seals and Spacers Separately](#)

- 8695 Replacement Seal & Collar for Bolt-In
- 8694 Replacement Seal for Bolt-In & Machine-In





9114

## ALUMINUM DEGREE CRANKSHAFT PULLEYS

All of EMPI's pulleys are made from High Grade Aluminum, Precision Machined and High Speed Polished to a Show Quality Shine. Featuring full 360-Degree timing marks, screened on with a special process for longevity. Increase horsepower with precision timing and valve settings. Adds that hi-performance look to any engine.

### STANDARD SIZE PULLEYS

Same size as stock pulleys. Available in Solid Billet Style or EMPI 5 Hole design, with black, red or blue degree numbers and marks. **(Note: Use with P/N: 9928 Belt)**



8779

- 9114 Polished Pulley w/Holes, Black Numbers
- 8914 Polished Pulley w/Holes, Blue Numbers
- 8915 Polished Pulley w/Holes, Red Numbers
  
- 8779 Polished Pulley, Billet Style, Black Numbers



9118

## SAND SEAL PULLEY KITS (STANDARD DIAMETER)

Same size as stock pulleys. Available in Bolt-In or Machine Case versions. All are 5 Hole style and come with black degree numbers and marks. Seals, collars and spacers are included. **(Note: P/N: 9118 Extra Long Bolt Kit must be used with Bolt-In Sand Seal Pulleys).** **(Note: Use with P/N: 9928 Belt).**



8688

- 8688 Sand Seal Pulley Kit, Bolt-In
- 8696 Sand Seal Pulley Kit, Machine-In



8694

8695

8688-6

- 8695 Replacement Seal & Collar for Bolt-In
- 8694 Replacement Seal for Bolt-In & Machine-In
- 8688-6 Pulley Spacer Set for Bolt-In, 2 pcs., Bulk
- 9118 Extra Long Chrome Pulley Bolt & Washer



8650

## STANDARD SIZE PULLEY KITS

Kit includes our 5 Hole Design Crank Pulley with Chrome Bolt and Washer, Chrome Alt/Gen Pulley, Finned Acrylic Cover in choice of color, Chrome Generator Nut and Spacer and Belt. Kits come complete with matching color screened onto the crank pulley.

- 8650 Standard Size Red Pulley Kit w/Red Cover
- 8651 Standard Size Blue Pulley Kit w/Blue Cover
- 8652 Standard Size Black Pulley Kit w/Smoke Cover



17-2918

## ADJUSTABLE TIMING POINTER

Machined Aluminum Pointer allows accurate timing within 4 degrees, with up to 20° adjustment for precise tuning and maximum performance. Fits all Type 1 engine cases with stock or power pulley **(Will not fit with 17-2811 and 17-2911 Serpentine Pulley Kits).**

- 17-2918 Adjustable Timing Pointer





# ENGINE COMPONENTS

## SERPENTINE BELT PULLEY SYSTEM

Serpentine Belt System is designed for style and performance. Easy installation and adjustment, quiet and smooth performance and increased belt life. A must for hi-reving engines. Polished or Black Anodized with permanent Laser-Etched numbers. Fits all Type I engine cases. Bolts to Alt/Gen Stand.

- 17-2911 **NEW!** Serpentine Belt Pulley System (Black Anodized)
- 17-2811 Serpentine Belt Pulley System (Polished)

- 17-2911-1 **NEW!** Replacement Belt Only for Double Bolt Design
- 17-2811-1 Replacement Belt Only for Single Bolt Design
- 17-2811-8 Replacement Bearings (Pair)



## POWER PULLEYS

Get a real increase in horsepower with the smaller diameter pulleys. Available in our exclusive 5 Hole design, with black degree numbers and marks. (Note: Use with P/N: 9120 Belt).

- 9115 Polished Pulley w/Holes, Black Numbers



## SAND SEAL POWER PULLEY KITS

Available in Bolt-in or Machine-in Case versions. All are 5 Hole style and come with black degree numbers and marks. Seals, collars and spacers are included. (Note:P/N: 9118 Extra Long Bolt must be used with Bolt-In Sand Seal Pulleys). (Note:Use with P/N: 9120 Belt).

- 8693 Sand Seal Pulley Kit, Bolt-In
- 8699 Sand Seal Pulley Kit, Machine-In
- 8695 Replacement Seal & Collar for Bolt-In
- 8694 Replacement Seal Only
- 8688-6 Pulley Spacers, for Bolt-In, Pair, Bulk
- 9118 Extra Long Chrome Pulley Bolt & Washer



## POWER PULLEY KIT

Includes P/N: 9115 Power Pulley with 5 holes and black degree numbers and belt.

- 9116 Power Pulley/Belt Kit, Black Numbers



## PULLEY BELTS

High Quality Belts for use with Standard Size Pulleys and Power Pulleys.

- 9120 Power Pulley Belt, 9.5 x 850mm
- 9928 Stock Size Pulley Belt, 9.5 x 905mm (Bulk P/N: 111 903 137D)
- 98-0090-B Stock Size Pulley Belt, 10.0 x 900mm (Ref. P/N: 111 903 137B)

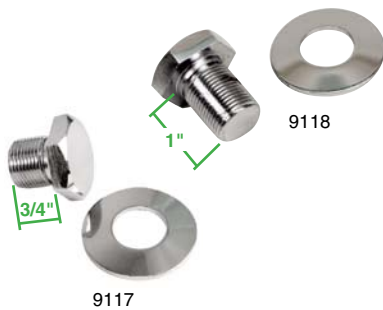

## CHROME PULLEY BOLT

Our Chrome Pulley Bolt and Washer adds the finishing touch to all crank pulley installations. Fits with any stock or custom pulley. **(Note: P/N: 9118 Extra Long Bolt must be used with Bolt-In Sand Seal Pulleys).**

- 9117** Chrome Bolt & Washer Set  
**9118** Chrome Bolt & Washer Set, for Bolt-In Sand Seal Pulleys (Extra Long Bolt)



## BILLET PULLEY BOLT

Have you gone totally Billet? Not if you don't have our silver zinc plated Billet Steel Pulley Bolt. Fits stock and aluminum pulleys. Has a 3/8" drive broach for slip-free tightening & loosening.

- 16-6801** [Billet Crankshaft Pulley Bolt](#)



## STOCK STYLE BROACHED PULLEY BOLT

Pulley bolt got you cranky? Stop fighting with large wrenches and sockets in such a confined area, EMPI's broached pulley bolts make it a snap by allowing you to insert a 3/8" drive ratchet or extension bar directly into the bolt. Works great when building engines too. Includes silver zinc plated bolt and washer.

- 16-6802** Stock Style Pulley Bolt w/Broach



## CHROME ALT / GEN NUT & SPACER

Chrome cone-shape spacer and smooth cap-style pulley nut adds the finished look to all stock and chrome pulleys.

- 9119** Chrome Alt/Gen Nut & Spacer, 2-Piece Set



## BILLET ALUMINUM 12-VOLT ALT / GEN PULLEY

EMPI now offers a 6061 T-6 aluminum front pulley half. Featuring machined holes in it for a bold new look which also functions to rid the belt area of dirt and debris. It is also offered complete with a zinc steel inner pulley half if you want a complete assembly.

- 33-1040** [Billet Aluminum Alt/Gen Pulley, Outer Half Only](#)  
**33-1041** [Billet Aluminum Alt/Gen Pulley, Outer Half w/Metal Inner](#)



## CHROME STOCK STYLE PULLEY

Chrome plated and polished to a show finish. **(Note: Use with Chrome Bolt and Washer P/N: 9117).**

- 8969** Chrome Stock Style Pulley



# ENGINE COMPONENTS

## 12/6-VOLT ALT / GEN PULLEY

Your choice of a Chrome or Gold-Zinc finish pulley along with the necessary related hardware. (Pulleys require a minimum of 10 shims to properly install and avoid damage)

**9166** 12-Volt Pulley, Gold-Zinc  
(Bulk P/N: 043 903 109)

**9191** 12-Volt Pulley, Chrome

**98-9012** 12-Volt Pulley, w/ Air Fins, Black  
(Bulk P/N: 040 903 109)

**98-0111** Alt/Gen Pulley Woodruff Key, 2 pcs.  
(Bulk P/N: N012 705 1)

**9197** Alt/Gen Shim Kit, 10 pcs.  
(Bulk P/N: 111 903 131A) (Bulk is Pack of 100 pcs.)



## BILLET ALTERNATOR / GENERATOR PULLEY

This billet pulley spins straight and true, the perfect addition to your killer engine. Available in anodized black or polished. Supplied with Woodruff Key.

**16-9706** Billet Alternator / Generator Pulley, Black, Each  
**16-9707** Billet Alternator / Generator Pulley, Polished, Each

**16-9708** Special Nut and Washer Set  
For 16-9706 and 16-9707 Pulley's Only

**16-9709** Shims (5) for Billet Pulley



## FINNED ALT / GEN PULLEY COVERS

See-Thru plastic with attractive fins. Matches other Finned accessories. Fits over Alt/Gen pulley.

**8925** Finned Pulley Cover, Clear  
**8926** Finned Pulley Cover, Red  
**8927** Finned Pulley Cover, Blue  
**8928** Finned Pulley Cover, Gold/Yellow  
**8929** Finned Pulley Cover, Smoke/Grey

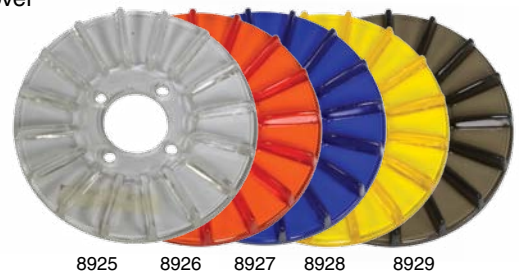

## CARB. SPACERS / ALTERNATOR CONVERSION

Sometimes necessary for Alternator Conversion. Two spacers available. 3245 spacer is for stock Solex/Brosol 28/30 Carburetor and is 1" thick with 2 1/8" hole to hole measurement. 16-9705 is for 34 Pict Carburetor and measures 3/8" thick with 2 11/16" hole to hole measurement.

**3245** Carb. Adapter Kit w/Studs, Nuts & Gaskets  
**16-9705** 34 PICT Carburetor Spacer, Each

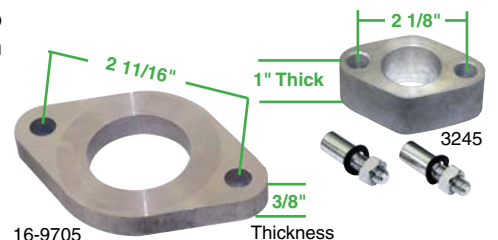

## PISTON AND CYLINDER SETS

High quality, proven performance.



### PISTON & CYL. SETS W/ CAST HYPEREUTECTIC PISTONS

98-1945-B	Piston & Cyl. Set, 77mm x 64mm Stroke, 36HP
98-1946-B	Piston & Cyl. Set, 77mm x 64mm Stroke, 40HP, 1200cc
98-1947-B	Piston & Cyl. Set, 83mm x 64mm Stroke, 40HP, Big Bore Slip-In
98-1948-B	Piston & Cyl. Set, 85.5mm x 69mm Stroke, 15-1600cc
98-1949-B	Piston & Cyl. Set, 87mm x 69mm Stroke, 1641cc Big Bore Slip-In
98-1950-B	Piston & Cyl. Set, 88mm x 69mm Stroke, 1700cc Slip-In
98-1951-B	Piston & Cyl. Set, 88mm x 69mm Stroke, 1700cc Machine-In Fits 85.5 Case, 90.5/92mm Head
98-1952-B	Piston & Cyl. Set, 90.5mm x 69mm Stroke, 1776cc
98-1953-B	Piston & Cyl. Set, 90.5mm x 82mm Stroke, 2110cc
98-1954-B	Piston & Cyl. Set, 92mm x 69mm Stroke, 1835cc
98-1955-B	Piston & Cyl. Set, 92mm x 82mm Stroke, 2180cc
98-1956-B	Piston & Cyl. Set, 94mm x 69mm Stroke, 1915cc
98-1957-B	Piston & Cyl. Set, 94mm x 82mm Stroke, 2276cc
98-1958-B <b>NEW!</b>	Piston & Cyl. Set, 92mm x 69mm Stroke, 1835cc, Thick Wall
98-1959-B <b>NEW!</b>	Piston & Cyl. Set, 92mm x 82mm Stroke, 2180cc, Thick Wall

*Both Piston Sets with thick wall must have case and heads cut for 94mm*

**NEW!**

### 94MM EXTRA LONG CYLINDERS

These Extra Long Cylinders (.800 inch longer than stock) are finned for superior cooling and are designed for longer stroke cranks and/or longer length connecting rods. Designed to be machined to your desired length and therefore eliminates the need to shim your cylinders to achieve the correct deck height.



B457512 **NEW!** Extra Long Cylinders, 94MM Bore

### MAHLE PISTON AND CYLINDER SETS

Mahle Pistons and Cylinders are the finest made. The Pistons are Forged and the cylinders are extra thick for superior strength. Designed to perform even with turbo charged and nitrous injected engines. All sets include piston rings, piston pins and retaining clips.  
(Tip: Best when used with Poly Piston Pin Retainer Buttons)



### PISTON & CYL. SETS W/CAST PISTONS

98-1969-B	Piston & Cyl. Set, 85.5mm, 1500-1600cc (Ref. P/N: 311 198 069F)
98-1986-B	Piston & Cyl. Set, 87mm x 69mm Stroke

**MAHLE**

### BOLT-ON BIG BORE PISTON & CYL. SETS W/FORGED PISTONS

98-1985-B	Piston & Cyl. Set, 85.5mm x 69mm Stroke, Forged
98-1987-B	Piston & Cyl. Set, 87mm x 69mm Stroke, Forged

### MACHINED TYPE BIG BORE PISTON & CYL. SETS W/FORGED PISTONS

98-1990-B	Piston & Cyl. Set, 90.5mm x 69mm Stroke, Forged
98-1991-B	Piston & Cyl. Set, 90.5mm x 82mm Stroke, Forged
98-1992-B	Piston & Cyl. Set, 92mm x 69mm Stroke, Forged
98-1993-B	Piston & Cyl. Set, 92mm x 82mm Stroke, Forged
98-1994-B	Piston & Cyl. Set, 94mm x 69mm Stroke, Forged
98-1995-B	Piston & Cyl. Set, 94mm x 82mm Stroke, Forged





# ENGINE COMPONENTS

## GRANT PISTON RING SETS

All Grant piston rings are made in the U.S.A. Choose Cast top rings or Chrome Top Rings. (Sold in complete engine sets).

### Standard Ring Sets

Contain compression rings which are manufactured to precision specifications from high grade grey iron castings. The top compression rings are black phosphate coated and beveled on the inside top, which gives a torsional twist characteristic and relieved on the lower ridge for oil scraping characteristics. The second compression ring is a scraper ring used in the second groove. Oil rings are 3-piece circumferential style, which provide quick seating, positive oil control and long life.

### Chrome Top Ring Sets

These ring sets have a top compression ring that is chrome plated and lapped for resistance to wear and scuffing, and faster seating.

- 98-1147-B **NEW!** Piston Ring Set – Cast Top Ring, 77mm (2 x 2 x 4mm) (Ref. P/N: 111 198 157B)
- 98-1148-B **NEW!** Piston Ring Set – Cast Top Ring, 77mm (2.5 x 2.5 x 4mm) (Ref. P/N: 111 198 157A)
- 98-1149-B **NEW!** Piston Ring Set – Cast Top Ring, 83mm (2 x 2 x 4mm) (Ref. P/N: 315 198 163)
- 98-1169-B Piston Ring Set – Cast Top Ring, 85.5mm, 1600cc (2 x 2 x 5mm) (Ref. P/N: 311 198 169A)
- 98-1203-B Piston Ring Set – Chrome Top Ring, 85.5mm, 1600cc (2 x 2 x 5mm)
- 98-1187-B Piston Ring Set – Cast Top Ring, 87mm (2 x 2 x 5mm) (Ref. P/N: 311 198 16987)
- 98-1204-B Piston Ring Set – Chrome Top Ring, 87mm (2 x 2 x 5mm)
- 98-1188-B Piston Ring Set – Cast Top Ring, 88mm (1.5 x 1.5 x 5mm) (Ref. P/N: 311 198 16988)
- 98-1205-B Piston Ring Set – Chrome Top Ring, 88mm (1.5 x 1.5 x 5mm)
- 98-1190-B Piston Ring Set – Cast Top Ring, 90.5mm (1.5 x 2 x 4mm) (Ref. P/N: 311 198 16990)
- 98-1206-B Piston Ring Set – Chrome Top Ring, 90.5mm (1.5 x 2 x 4mm)
- 98-1191-B Piston Ring Set – Cast Top Ring, 90.5mm (2 x 2 x 4.8mm) (Ref. P/N: 311 198 16991)
- 98-1207-B Piston Ring Set – Chrome Top Ring, 90.5mm (2 x 2 x 4.8mm)
- 98-1192-B Piston Ring Set – Cast top ring, 92mm (1.5 x 2 x 4mm) (Ref. P/N: 311 198 16992)
- 98-1208-B Piston Ring Set – Chrome Top Ring, 92mm (1.5 x 2 x 4mm)
- 98-1144-B **NEW!** Piston Ring Set – Cast Top Ring, 92mm (2 x 2 x 4mm)
- 98-1145-B **NEW!** Piston Ring Set – Chrome Top Ring, 92mm (2 x 2 x 4mm)
- 98-1194-B Piston Ring Set – Cast Top Ring, 94mm (1.5 x 2 x 4mm) (Ref. P/N: 311 198 16994)
- 98-1209-B Piston Ring Set – Chrome Top Ring, 94mm (1.5 x 2 x 4mm)
- 98-1195-B Piston Ring Set – Cast top Ring, 94mm (2 x 2 x 4mm) (Ref. P/N: 311 198 16995)
- 98-1210-B Piston Ring Set – Chrome Top Ring, 94mm (2 x 2 x 4mm)
- 98-1200-B Piston Ring Set – Cast Top Ring, 90mm Type 4
- 98-1211-B Piston Ring Set – Chrome Top Ring, 90mm Type 4
- 98-1201-B Piston Ring Set – Cast Top Ring, 93mm Type 4
- 98-1212-B Piston Ring Set – Chrome Top Ring, 93mm Type 4
- 98-1202-B Piston Ring Set – Cast Top Ring, 94mm Type 4
- 98-1213-B Piston Ring Set – Chrome Top Ring, 94mm Type 4

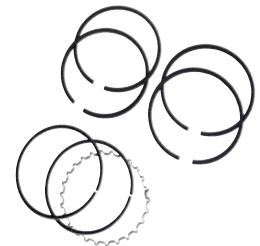

Chrome Top Ring

## TOTAL SEAL GAPLESS PISTON RING SETS & 2ND RING SETS

Total Seal's patented Gapless® Piston Rings provide increased performance through unmatched sealing of the cylinder and combustion gases in the combustion chamber providing increased horsepower, torque and longer engine life. Available in Complete Sets or 2nd Ring Sets only.

- 98-1890-B T/S Piston Ring Set, 85.5mm, 1600cc (2 x 2 x 5mm)
- 98-1895-B T/S 2nd Ring Set ONLY, 85.5mm, 1600cc (2 x 2 x 5mm)
- 98-1891-B T/S Piston Ring Set, 87mm (2 x 2 x 5mm)
- 98-1896-B T/S 2nd Ring Set ONLY, 87mm (2 x 2 x 5mm)
- 98-1892-B T/S Piston Ring Set, 90.5mm (1.5 x 2 x 4mm)
- 98-1897-B T/S 2nd Ring Set ONLY, 90.5mm (1.5 x 2 x 4mm)
- 98-1893-B T/S Piston Ring Set, 92mm (1.5 x 2 x 4mm)
- 98-1898-B T/S 2nd Ring Set ONLY, 92mm (1.5 x 2 x 4mm)
- 98-1894-B T/S Piston Ring Set, 94mm (1.5 x 2 x 4mm)
- 98-1899-B T/S 2nd Ring Set ONLY, 94mm (1.5 x 2 x 4mm)



98-1893-B

## POLY PISTON PIN RETAINER BUTTONS

Prevent costly engine damage. The failure of the small and fragile stock clips that are easily damaged during installation can cause total engine destruction. Retainers are easy to install and will not break or wear out. Easy press-in installation. Sizes for all piston diameters. 8 piece engine set. **Buttons may fit tight in different manufacturers wrist pins.**

4070	85.5mm Retainer Buttons, Set of 8
4071	87/88mm Retainer Buttons, Set of 8
4073	90.5mm Retainer Buttons, Set of 8
4074	92mm Retainer Buttons, Set of 8
4075	94mm Retainer Buttons, Set of 8



## PISTON PIN RETAINERS

We offer two types. The Spiral retainers fit securely in the retainer groove to prevent galling by the pin. Hi-performance engine builders have always favored the Tru-Arc type. Fits all pistons with 22mm diameter pins. Set of 8.

4068	Tru-Arc Piston Pin Retainers, Set of 8
4069	Spiral Piston Pin Retainers, Set of 8



4068



4069

## CYLINDER SHIM SETS

Steel shims allow for adjusting deck height without machining the pistons. Corrects for increase in stroke and compensates when case is surface machined. Clearanced for standard 8mm studs. Sold in sets of 4. *\*If noted, the shims have been clearanced for 8mm and 10mm studs*

### 85.5mm / 87mm / 88mm CYLINDER SHIMS

21-6010	.010"
21-6020	.020"
21-6030	.030"
21-6040	.040"
21-6060	.060"
21-6090	.090"

### 90.5mm / 92mm CYLINDER SHIMS

21-7020 *	.010"
21-7030 *	.020"
21-7040 *	.030"
21-7050 *	.040"
21-7068 *	.060"
21-7076 *	.090"

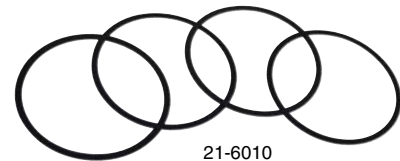

21-6010

### 94mm CYLINDER SHIMS

21-7410 *	.010"
21-7420 *	.020"
21-7430 *	.030"
21-7440 *	.040"
21-7460 *	.060"
21-7490 *	.090"

### 1700cc, 1800cc and 2.0 TYPE 4 CYLINDER SHIMS

21-7510	.010"
21-7520	.020"
21-7530	.030"
21-7540	.040"
21-7560	.060"
21-7590	.090"



21-7410

## CYLINDER HEAD SPACERS

Steel spacers allow for adjusting deck height / compression ratio easily without removing the cylinders. Compensates for zero deck height when heads have been machined or in stroker setups. Sold in sets of 4 only.

21-5008	Head Spacers, 1500-1600cc, .030", Set of 4
21-7616	Head Spacers, 1500-1600cc, .040", Set of 4
21-5009	Head Spacers, 1500-1600cc, .060", Set of 4



21-5008

## COPPER HEAD GASKETS

Many top engine builders recommend and use Copper Head Gaskets when adjusting deck height / compression ratio in performance applications. Available in sets of 4 in popular large cylinder sizes.

16-9529	Copper Head Gaskets 90.5mm/92mm .040" (4)
16-9530	Copper Head Gaskets 90.5mm/92mm .050" (4)
16-9531	Copper Head Gaskets 90.5mm/92mm .060" (4)
16-9532	Copper Head Gaskets 94mm .040" (4)
16-9533	Copper Head Gaskets 94mm .050" (4)
16-9534	Copper Head Gaskets 94mm .060" (4)

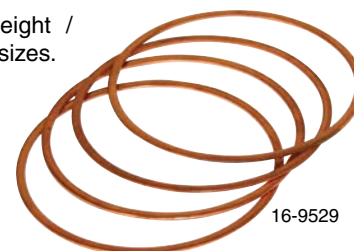

16-9529



# ENGINE COMPONENTS

## EMPI GTV-2 CNC WEDGE-PORTED CYLINDER HEADS

**NEW!**

We start with the "best in class" EMPI GTV-2 Cylinder head casting and let a 5 Axis CNC Mill work it's magic to increase flow. Resulting in the best bang for your buck in increased horsepower. Our programs cut the Intake, Exhaust and Chamber with CNC precision. You now have a smooth, ready to bolt on finished head. The GTV-2 Cylinder Head casting eliminates the need for any welding – even with our massive Stage 3 port.

- BEEFED-UP INTAKE & EXHAUST PORTS FOR MASSIVE PORTING WITHOUT THE NEED FOR WELDING
- SPECIAL ALUMINUM ALLOY FOR STRENGTH AND DURABILITY...PLUS REPAIRABLE
- ADDED MATERIAL SURROUNDING THE COMBUSTION CHAMBER FOR DEEP FLY CUTTING
- EXHAUST AIR PASSAGES ARE CLEAR FOR PROPER COOLING
- 12MM, 3/4" REACH PLUG
- COMPETITION DUAL VALVE SPRINGS, CHROMOLY RETAINERS, HARDENED KEEPERS, BRONZE VALVE GUIDES, S/S VALVES & GASKETS
- HI-PERFORMANCE 3-ANGLE VALVE JOB

## ALL NEW CASTING

Available in three Wedge-Port Designs



GTV-2 Stage 3 Wedge-Ported Cylinder Head

Available in three Wedge-Port Designs, all feature Stainless Steel Valves, Racing Valve Seats, Bronze Valve Guides, New 4037 Hi-Performance Dual Valve Springs, Chromoly Retainers, Hardened Keepers, Gaskets, Rocker, Exhaust and Intake Studs. Complete with a professional Performance Valve job & assembly. Three Wedge-Port designs to bring out the horsepower in all popular engine combinations. All three designs have been Race-Proven.



### STAGE 1 WEDGE-PORT

40 x 35.5 Stainless Steel Valves  
90.5 / 92mm or 94mm Bore



### STAGE 2 WEDGE-PORT

42 x 37.5 Stainless Steel Valves  
90.5 / 92mm or 94mm Bore



### STAGE 3 WEDGE-PORT

42 x 37.5 Stainless Steel Valves  
90.5 / 92mm or 94mm Bore

44 x 37.5 Stainless Steel Valves  
90.5 / 92mm or 94mm Bore

## EMPI GTV-2 CNC WEDGE-PORTED CYLINDER HEADS

### STAGE 1 WEDGE-PORT

98-1430-B **NEW!** EMPI GTV-2 Stage 1 – Wedge-Port, 40 x 35.5, 92mm, Pair

98-1431-B **NEW!** EMPI GTV-2 Stage 1 – Wedge-Port, 40 x 35.5, 94mm, Pair



GTV-2 Stage 1  
Wedge-Ported Cylinder Head

**170 CFM**

**72cc\*  
Chamber**

### STAGE 2 WEDGE-PORT

98-1432-B **NEW!** EMPI GTV-2 Stage 2 – Wedge-Port, 42 x 37.5, 92mm, Pair

98-1433-B **NEW!** EMPI GTV-2 Stage 2 – Wedge-Port, 42 x 37.5, 94mm, Pair



GTV-2 Stage 2  
Wedge-Ported Cylinder Head

**195 CFM**

**72cc\*  
Chamber**

### STAGE 3 WEDGE-PORT

98-1434-B **NEW!** EMPI GTV-2 Stage 3 – Wedge-Port, 42 x 37.5, 92mm, Pair

98-1435-B **NEW!** EMPI GTV-2 Stage 3 – Wedge-Port, 42 x 37.5, 94mm, Pair

98-1436-B **NEW!** EMPI GTV-2 Stage 3 – Wedge-Port, 44 x 37.5, 92mm, Pair

98-1437-B **NEW!** EMPI GTV-2 Stage 3 – Wedge-Port, 44 x 37.5, 94mm, Pair

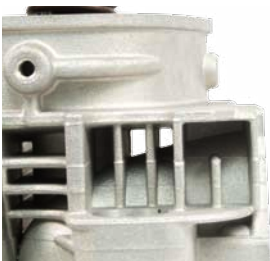

GTV-2 Stage 3  
Wedge-Ported Cylinder Head

**210 CFM**

**72cc\*  
Chamber**

**\*94mm Bore**





# ENGINE COMPONENTS

## EMPI CNC MATCH-PORTED MANIFOLDS

CNC Machined manifolds to match the EMPI GTV-2 Wedge-Port Heads. One of the benefits of CNC porting is that you can replace your manifolds at any time and still have an exact match to your cylinder heads. Port-Matched for Stage 1, 2 & 3 Cylinder Heads in a variety of applications. Sets are complete with all hardware and gaskets.

**43-1028** **NEW!** Stage 1 Match-Ported Short Manifolds for 48/51 EPC/IDA Carburetors, Pair

**43-1029** **NEW!** Stage 2 Match-Ported Short Manifolds for 48/51 EPC/IDA Carburetors, Pair

**43-1030** **NEW!** Stage 3 Match-Ported Short Manifolds for 48/51 EPC/IDA Carburetors, Pair

43-1028 **NEW!**  
Manifolds



43-1028



43-1029



43-1030 Kit

**43-1031** **NEW!** Stage 1 Match-Ported Tall Manifolds for 48/51 EPC/IDA Carburetors, Pair

**43-1032** **NEW!** Stage 2 Match-Ported Tall Manifolds for 48/51 EPC/IDA Carburetors, Pair

**43-1033** **NEW!** Stage 3 Match-Ported Tall Manifolds for 48/51 EPC/IDA Carburetors, Pair



43-1032



43-1031



43-1033

**43-1025** Stage 1 Match-Ported Off-Set Manifolds for HMPX/IDF/Dellorto Carburetors, Pair

**43-1026** Stage 2 Match-Ported Off-Set Manifolds for HMPX/IDF/Dellorto Carburetors, Pair

**43-1027** Stage 3 Match-Ported Off-Set Manifolds for HMPX/IDF/Dellorto Carburetors, Pair

43-1026 **NEW!**  
Manifolds



43-1026



43-1025



43-1027

**43-1034** **NEW!** Stage 1 Match-Ported Tall Manifolds w/ NOS Boss for HMPX/IDF/Dellorto Carburetors, Pair

**43-1035** **NEW!** Stage 2 Match-Ported Tall Manifolds w/ NOS Boss for HMPX/IDF/Dellorto Carburetors, Pair

**43-1036** **NEW!** Stage 3 Match-Ported Tall Manifolds w/ NOS Boss for HMPX/IDF/Dellorto Carburetors, Pair



43-1034



43-1035 Kit



43-1036 Kit

## EMPI CNC MATCH-PORTED GASKETS

Replacement Intake Gaskets for Stage 1, 2 & 3 Cylinder heads/manifolds.

**3260** **NEW!** Stage 1 Intake Gaskets, Pair

**3261** **NEW!** Stage 2 Intake Gaskets, Pair

**3262** **NEW!** Stage 3 Intake Gaskets, Pair



3262



3260



3261

## EMPI GTV-2 RACING CYLINDER HEADS



98-1330-B

**56cc Chamber**



**Additional Material for Porting**



**Mild or Wild No Welding Required**

The EMPI GTV-2 Cylinder head casting out-classes all the competition! Beefed up Intake & Exhaust Ports allow massive porting without the need for welding. Special Aluminum Alloy for Strength and Durability – and is repairable. **Intake & Exhaust ports are 20% larger than stock.** Has added material surrounding the Combustion Chamber for deep fly cutting. Thick interior walls for porting. Exhaust Air Passages are clear for excellent cooling. Machined for 12mm 3/4" Reach Plug. The GTV-2 Casting allows you to run as-is - an exceptional Performance Head, or have any Hand or CNC Port configuration....from Mild to Wild!

### GTV-2 DUAL PORT CYLINDER HEADS – BARE

Bare Head comes with 40 x 35.5mm Valve Seats and Bronze Valve Guides installed. Rocker, Exhaust and Intake Studs are included. Standard 85.5mm Bore and 56cc Chamber.

**98-1330-B** **NEW!** GTV-2 Dual Port Cylinder Head, 85.5mm, Bare, Each



**NEW!**  
98-1330-B

### GTV-2 DUAL PORT CYLINDER HEADS – COMPLETE

Complete GTV-2 Dual Port Heads, assembled with 40 x 35.5 Stainless Steel Valves, Single or Dual Hi-Rev Valve Springs, Chromoly Retainers, Hardened Keepers, Rocker, Exhaust and Intake Studs. 85.5mm Bore and 56cc Chamber.

**98-1331-B** **NEW!** GTV-2 Dual Port Cylinder Head, 85.5mm Bore, Single Valve Springs - Complete, Each

**98-1332-B** **NEW!** GTV-2 Dual Port Cylinder Head, 85.5mm Bore, Dual Valve Springs – Complete, Each



**NEW!**  
98-1332-B

### GTV-2 DUAL PORT CYLINDER HEADS w/ COMPETITION VALVE JOB – COMPLETE

Complete GTV-2 Dual Port Heads, with your choice of Bore and Valve Sizes, assembled with Stainless Steel Valves, Single or Dual Hi-Rev Valve Springs, Chromoly Retainers, Hardened Keepers, Rocker, Exhaust and Intake Studs. Complete with a Professional Performance Valve Job and assembly. 56cc Chamber.

**98-1381-B** **NEW!** GTV-2 Dual Port Cylinder Head, 40 x 35.5 S/S Valves, Single Valve Springs for 85.5mm Bore, Complete w/ Competition Valve Job, Each

**98-1382-B** **NEW!** GTV-2 Dual Port Cylinder Head, 40 x 35.5 S/S Valves, Dual Valve Springs for 85.5mm Bore, Complete w/ Competition Valve Job, Each

**98-1333-B** **NEW!** GTV-2 Dual Port Cylinder Head, 40 x 35.5 S/S Valves, Single Valve Springs for 92mm Bore, Complete w/ Competition Valve Job, Each

**98-1334-B** **NEW!** GTV-2 Dual Port Cylinder Head, 40 x 35.5 S/S Valves, Dual Valve Springs for 92mm Bore, Complete w/ Competition Valve Job, Each

**98-1335-B** **NEW!** GTV-2 Dual Port Cylinder Head, 40 x 35.5 S/S Valves, Single Valve Springs for 94mm Bore, Complete w/ Competition Valve Job, Each

**98-1336-B** **NEW!** GTV-2 Dual Port Cylinder Head, 40 x 35.5 S/S Valves, Dual Valve Springs for 94mm Bore, Complete w/ Competition Valve Job, Each

**98-1438-B** **NEW!** GTV-2 Dual Port Cylinder Head, 42 x 37.5 S/S Valves, Dual Valve Springs for 92mm Bore, Complete w/ Competition Valve Job, Each

**98-1439-B** **NEW!** GTV-2 Dual Port Cylinder Head, 42 x 37.5 S/S Valves, Dual Valve Springs for 94mm Bore, Complete w/ Competition Valve Job, Each

**98-1440-B** **NEW!** GTV-2 Dual Port Cylinder Head, 44 x 37.5 S/S Valves, Dual Valve Springs for 92mm Bore, Complete w/ Competition Valve Job, Each

**98-1441-B** **NEW!** GTV-2 Dual Port Cylinder Head, 44 x 37.5 S/S Valves, Dual Valve Springs for 94mm Bore, Complete w/ Competition Valve Job, Each



**NEW!**  
98-1335-B

**56cc Chamber**





# ENGINE COMPONENTS

## EMPI HIGH PERFORMANCE CYLINDER HEADS

The EMPI High Performance Cylinder head casting are made from a Special Aluminum Alloy for strength and rigidity – and is repairable. Intake & Exhaust ports are 20% larger than stock, with thick interior walls for porting and Exhaust Air Passages are clear for excellent cooling. Machined for 12mm 3/4" Reach Plug.

- Special aluminum alloy for superior strength and rigidity
- Permanent mold casting
- 12mm, 3/4" reach plugs moved away from valve seats to eliminate stress cracks
- Bronze valve guides
- Valve seats installed (40mm Intake / 35.5mm Exhaust)
- Increased port wall thickness for porting
- Exhaust air passages are clear for proper cooling
- Weldable for custom work
- Rocker, Exhaust and Intake studs included
- Stainless steel valves
- 20% Larger intake and exhaust ports

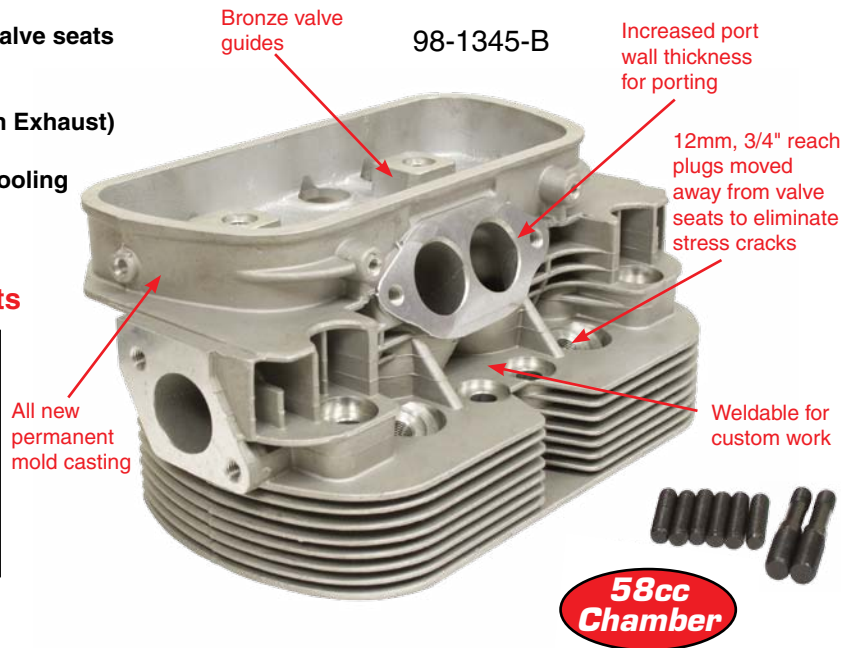

**58cc Chamber**

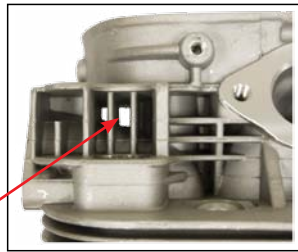

Exhaust air passages are clear for proper cooling.

**58cc Chamber**

### DUAL PORT CYLINDER HEADS - BARE

Bare Head comes with 40 x 35.5mm Valve Seats and Bronze Valve Guides installed. Rocker, Exhaust and Intake Studs are included. Standard 85.5mm bore. 58cc Chamber.

**98-1345-B** Dual Port Cylinder Head, 85.5mm, Bare, Each  
(Ref. P/N: 042 101 355CH)

### DUAL PORT CYLINDER HEADS - COMPLETE

Complete Hi-Performance Dual Port Heads, assembled with 40 x 35.5mm Stainless Steel Valves, Single or Dual Hi-Rev Valve Springs, Chromoly Retainers, Hardened Keepers, Rocker, Exhaust and Intake Studs. Standard 85.5mm Bore. 58cc Chamber.

**98-1346-B** Dual Port Cylinder Head, 85.5mm Bore, Single Valve Springs – Complete, Each

**98-1347-B** Dual Port Cylinder Head, 85.5mm Bore, Dual Valve Springs – Complete, Each



### DUAL PORT CYLINDER HEADS W/COMPETITION VALVE JOB - COMPLETE

Complete Hi-Performance Dual Port Heads, with your choice of Bore size, assembled with 40 x 35.5 Stainless Steel Valves, Single or Dual Hi-Rev Valve Springs, Chromoly Retainers, Hardened Keepers, Rocker, Exhaust and Intake Studs. Complete with a Professional Performance Valve Job and assembly. 58cc Chamber.

**98-1386-B** **NEW!** Dual Port Cylinder Head w/Competition Valve Job, for 85.5mm w/Single Springs – Complete, Each

**98-1387-B** **NEW!** Dual Port Cylinder Head w/Competition Valve Job, for 85.5mm w/Dual Springs – Complete, Each

**98-1390-B** Dual Port Cylinder Head w/Competition Valve Job, for 92mm w/Single Springs – Complete, Each

**98-1391-B** Dual Port Cylinder Head w/Competition Valve Job, for 92mm w/Dual Springs – Complete, Each

**98-1392-B** Dual Port Cylinder Head w/Competition Valve Job, for 94mm w/Single Springs – Complete, Each

**98-1393-B** Dual Port Cylinder Head w/Competition Valve Job, for 94mm w/Dual Springs – Complete, Each



## EMPI STOCK DUAL PORT CYLINDER HEADS

**ALL NEW  
CASTING**

The EMPI Stock Dual Port Cylinder Head casting is explicitly modeled after the celebrated 040.101.375.13. Arguably the best stock cylinder head ever produced. No added this or that – just a pure Stock Cylinder Head designed to fit, run, cool and last like the original. Intake & Exhaust Air Passages are as clear as the original for excellent cooling and even comes with the stock Tin. Made from a Special Aluminum Alloy for strength and rigidity and is repairable. Comes with 35.5 Intake and 32mm Exhaust Seats, Bronze Valve Guides, Rocker, Exhaust and Intake Studs. These heads are available in both Standard 14mm 1/2" reach and 12mm 3/4" reach Spark Plugs.

**53cc  
Chamber**



**NEW!**

98-1356-B

Available in both  
14mm 1/2" Reach and  
12mm 3/4" Reach

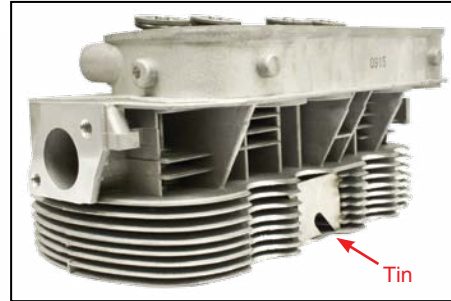

8 Cooling Fins w/ OEM Style Tin



Knife-Edged Fins for Maximum Air Flow and Cooling

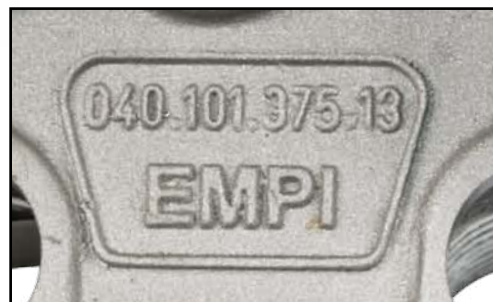

New Casting Mirrored after the Celebrated  
040.101.375.13 Casting



**53cc  
Chamber**

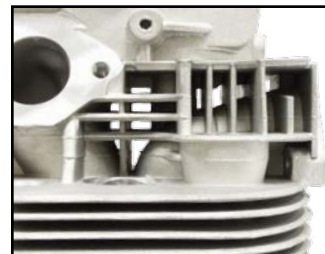

Intake & Exhaust Passages are Large and  
Clear for Excellent Cooling



# ENGINE COMPONENTS

## STOCK DUAL PORT CYLINDER HEADS - BARE

Bare Head comes with 35.5 Intake and 32mm Exhaust Seats and Bronze Valve Guides Installed. Rocker, Exhaust and Intake Studs are included. Available for both Standard 14mm 1/2" reach and 12mm 3/4" reach Spark Plugs. 53cc Chamber.

**53cc Chamber**

**98-1355-B** Stock Dual Port Cylinder Head, for 14mm 1/2" reach Plug  
85.5mm Bore - Bare, Each  
(Ref. P/N: 043 101 355C) **SCORE APPROVED**

**98-1324-B** **NEW!** Stock Dual Port Cylinder Head, for 12mm 3/4" reach Plug  
85.5mm Bore - Bare, Each



98-1355-B



## STOCK DUAL PORT CYLINDER HEADS - COMPLETE

Complete Stock Dual Port Cylinder Heads assembled with 35.5 x 32mm Stainless Steel Valves, Stock Valve Springs, Steel Retainers, Hardened Keepers, Rocker, Exhaust and Intake Studs. Available for both Standard 14mm 1/2" reach and 12mm 3/4" reach Spark Plugs. 53cc Chamber.

**53cc Chamber**

**98-1356-B** Stock Dual Port Cylinder Head, for 14mm 1/2" reach Plug  
85.5mm Bore - Complete, Each  
(Ref. P/N: 043 101 355CK) **SCORE APPROVED**

**98-1325-B** **NEW!** Stock Dual Port Cylinder Head, for 12mm 3/4" reach Plug  
85.5mm Bore - Complete, Each



98-1356-B

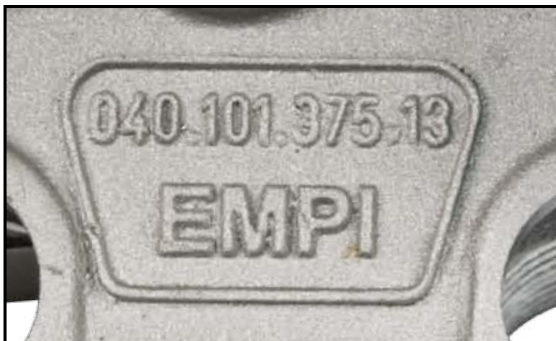

New Casting Mirrored after the Celebrated  
040.101.375.13 Casting

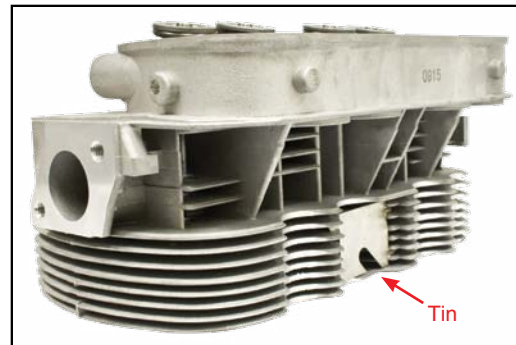

8 Cooling Fins w/ OEM Style Tin



## HARDENED VALVE LASH CAPS

Hardened valve lash caps prevent the valve stem tip from mushrooming under the load of heavy valve spring pressure.

**4006** Hardened Valve Lash Caps, Set of 8



## VALVE LOCKS

Precision fit and heat-treated valve locks prevent valve groove wear and failure. Compatible with stock and stainless steel valves, as well as with all stock and EMPI retainers.

**4044** Valve Locks, 8 Pairs  
(Bulk P/N: 113 109 651A) Each



## VALVE GUIDES

**Silicone Bronze** Valve Guides reduce friction, improve lubrication and offer extended reliability. Features a shouldered design. Sold in bulk, each.

**4002** Valve Guide, for 8mm Intake & Exhaust, Bulk, Each  
(Ref. P/N: 113 101 401BR)



## RACING VALVE GUIDES

**Silicone Bronze** is by far the most superior valve guide material available today. Our valve guides are strong and durable. These valve guides reduce friction, improve lubrication and offer extended reliability. Sold in sets of 4.

**B405600** **NEW!** Silicone-Bronze Race Guides, Intake (4)  
**B405700** **NEW!** Silicone-Bronze Race Guides, Exhaust (4)



## CASE SAVER INSERTS

Repair stripped and worn head stud threads. Case savers provide greater hold. Each kit has 8 inserts. **\*NOTE: Engine must be disassembled and case machined.**

**4011** Case Saver, 10mm-1.5 I.D. x 1/2-20 O.D., Set of 8  
**4012** Case Saver, 10mm-1.5 I.D. x 14mm-2.0 O.D., Set of 8  
**4003** **NEW!** Case Saver, 8mm-1.25 I.D. x 14mm-2.0 O.D., Set of 8  
**4004** **NEW!** Case Saver, 8mm-1.25 I.D. x 12mm-1.5 O.D., Set of 8



## TOTAL SEAL 'QUICKSEAT' DRY FILM POWDER

Quickseat is a powder Total seal has developed for quicker, more effective ring seating. Simply spread Quickseat on the cylinders and assemble the engine as you usually would. You will experience improved ring seating. In extensive dyno testing, use of Quickseat in conjunction with Total Seal Gapless piston rings allowed for leakage rates to be 0-1% after about 5 minutes of break-in time on the engine.

**98-1900** Total Seal 'Quickseat' Dry Film Powder, 2 Gram Container, Each



# ENGINE COMPONENTS

## HI-PERFORMANCE PUSH RODS

Resists flexing at high RPM's under the loads of high lift cams and heavy valve spring pressures. A must with any dual spring application. Made from the highest quality heat-treated 5/16" steel tubing, ends are pre-installed and push rods are 11.078" overall length. Fits 1300-1600cc.

**4033** Stock Length Hi-Performance Push Rods, Set of 8  
(Bulk P/N: 311 109 301A) Each



## CHROMOLY PUSH RODS

Chromoly push rods are lighter and stronger than regular steel push rods. The 3/8" tubing offers maximum strength to maintain no flex operation at higher RPM's under the stress of high lift cams and high-rev. valve springs. Available in Stock Length fully assembled or custom Cut-to-Length style.

**4034** Cut to Length, 11.600" Long, 3/8" Chromoly Push Rods, Set of 8

**4035** Stock Length, Assembled 11.060" Long, 3/8" Chromoly Push Rods, Set of 8



## ALUMINUM PUSH RODS

Lightweight strong 3/8" diameter push rods for the discerning engine builder. These units offer the ultimate in strength versus weight. Available in uncut lengths, to suit your individual application. Easily cut & installed in any VW engine.

**B405400** **NEW!** Aluminum 3/8" Diameter Push Rods, Uncut (8)



## CHROMOLY PUSH RODS

Made from 4130 chromoly steel. Both pushrod tubes and ends are designed to withstand the demands of high RPM and heavy spring loads. 3/8" diameter resists flex to prevent damage to other valve-train components. When buying pushrods be sure it's chromoly, not just steel. Available in various lengths.

**B405310** **NEW!** 3/8" Chromoly Push Rods, 10.650 OAL, (8)

**B405313** **NEW!** 3/8" Chromoly Push Rods, 10.800 OAL, (8)

**B405311** **NEW!** 3/8" Chromoly Push Rods, 11.060 OAL, (8)

**B405312** **NEW!** 3/8" Chromoly Push Rods, 11.350 OAL, (8)

**B405314** **NEW!** 3/8" Chromoly Push Rods, 11.600 OAL, (8)



## PUSH ROD MEASURING TOOL

Adjust out, lock down, measure, and cut push rods.

**16-9600** Push Rod Measuring Tool, Each



16-9600



4037 **NEW!**

## RACING DUAL VALVE SPRINGS

Insure against valve spring fatigue and breakage and stop that valve float with the best valve springs on the market! Hand checked and magnafluxed for top quality. The Outer spring is 1.246" diameter using .153" wire diameter and the Inner features .910" diameter using .113" wire diameter. Together they will lift .630" and more with coil bind at .800". Valve guide boss must be machined for all dual spring kits.

4037 **NEW!** Racing Dual Valve Springs, Set of 8



4041 **NEW!**

## RACING DUAL VALVE SPRING KIT

Kit includes Racing Dual Valve Springs, Chromoly Retainers and Hardened Valve Locks. **Valve guide boss must be machined for all dual spring kits. Same Dual Springs as P/N: 4037.**

4041 **NEW!** Racing Dual Valve Spring Kit



4040

## HI-PERFORMANCE VALVE SPRINGS

Hand checked and magnafluxed for top quality, this is the best Single Valve Spring on the market for Hi-Performance street applications. 1.255" Diameter and approx. 2.135" Free Length offers 114# @ 1.500" installed height - 216# @ 500" lift. Bind @ .932" Recommend for Camshafts up to 500" lift.

4040 High-Rev. Single Valve Springs, Set of 8

4042 High-Rev. Dual Valve Springs, Set of 8



4045

## HIGH-REV. VALVE SPRING KITS

Everything you need to prepare your heads for high-lift cam use and high RPM applications. Kits include Single or Dual Hi-Performance Valve Springs, **Chromoly Retainers and Hardened Valve Locks. Valve guide boss must be machined for all dual spring kits. Same Dual Springs as P/N: 4037. Same Single Springs as P/N: 4040.**

4045 High-Rev. Single Spring Kit

4060 High-Rev. Dual Spring Kit



## STOCK REPLACEMENT VALVE SPRINGS

Valve Springs lose tension after years of service, resulting problems can include low compression and burnt exhaust valves. These New Springs are a must for all stock valve jobs. These springs are approximately 140 lbs at seat pressure and the free length is 2.025".

98-1923-B Stock Valve Spring, 1200-1600cc, Each  
(Ref. P/N: 113 109 623C)



B405515

**NEW!**

B405860

**NEW!**

## HARDENED SPRING SHIMS

Hardened valve spring shims for setting proper spring installed height. Provides excellent seat surface for high pressure springs by preventing cutting into the heads. Available in a variety of ways to suit all applications.

B405515 **NEW!** Single Spring Shims, .015, (8)

B405530 **NEW!** Single Spring Shims, .030, (8)

B405560 **NEW!** Single Spring Shims, .060, (8)

B405815 **NEW!** Dual Spring Shims, .015, (8)

B405830 **NEW!** Dual Spring Shims, .030, (8)

B405860 **NEW!** Dual Spring Shims, .060, (8)





## STAINLESS STEEL VALVES

These valves are high quality one piece forged stainless steel with hardened stem to prevent mushrooming. 8mm stem diameter. Suitable for both intake and exhaust. Sold in bulk, each, or skinpacked (4) to a card.

- 98-1932-B** S/S Valve, 32mm, Bulk, Each  
(Ref. P/N: 113 109 612A)
- 98-1935-B** S/S Valve, 35.5mm, Bulk, Each  
(Ref. P/N: 311 109 601)
- 98-1937-B** S/S Valve, 37mm, Bulk, Each
- 98-1938-B** **NEW SIZE!** S/S Valve, 37.5mm, Bulk, Each
- 98-1940-B** S/S Valve, 40mm, Bulk, Each
- 98-1942-B** S/S Valve, 42mm, Bulk, Each
- 98-1944-B** S/S Valve, 44mm, Bulk, Each

- 
- 4046** **NEW!** S/S Valve, 32mm, Skinpacked (4)
  - 4047** **NEW!** S/S Valve, 35.5mm, Skinpacked (4)
  - 4048** **NEW!** S/S Valve, 37mm, Skinpacked (4)
  - 4052** **NEW SIZE!** S/S Valve, 37.5mm, Skinpacked (4)
  - 4049** **NEW!** S/S Valve, 40mm, Skinpacked (4)
  - 4050** **NEW!** S/S Valve, 42mm, Skinpacked (4)
  - 4051** **NEW!** S/S Valve, 44mm, Skinpacked (4)



## HEAVY DUTY VALVE SEATS

To compliment any new valve installation, these seats are designed to provide maximum resistance to hi-impact and extreme head temperatures. Your engine breathes easier due to proper air flow. Sets of four.

- B402600** **NEW!** Heavy Duty Valve Seats, for 35.5mm Valves, Skinpacked (4)
- B402700** **NEW!** Heavy Duty Valve Seats, for 37mm Valves, Skinpacked (4)
- B402800** **NEW!** Heavy Duty Valve Seats, for 37.5mm Valves, Skinpacked (4)
- B402400** **NEW!** Heavy Duty Valve Seats, for 40mm Valves, Skinpacked (4)
- B404300** **NEW!** Heavy Duty Valve Seats, for 42mm Valves, also can fit 44mm Valves Skinpacked (4)
- B402500** **NEW!** Heavy Duty Valve Seats, for 44mm Valves, Skinpacked (4)



## VALVE LOCKS

Precision fit and heat-treated valve locks prevent valve groove wear and failure. Compatible with stock and stainless steel valves, as well as with all stock and EMPI retainers.

- 4044** Valve Locks, 8 Pairs  
(Bulk P/N: 113 109 651A) Each





4013

## SPARK PLUG INSERTS

Repair stripped spark plug threads with 16 x 1.5mm threaded inserts. Repairs to use 14mm, 1/2" reach spark plugs. Cylinder head removal is required.

**4013** Spark Plug Inserts, 14mm – 1/2" Reach, Set of 4



## CHROMOLY VALVE SPRING RETAINERS

Manufactured from super strong lightweight chromoly, precision cnc machined to an exacting tolerance and heat-treated. These retainers are virtually unbreakable. Use with single or dual spring setups.

**4015** Chromoly Spring Retainers, Set of 8



## ALUMINUM VALVE SPRING RETAINERS

Precision machined, these light weight hi-performance retainers will stand up to the demands of most performance engines.

**4016** Aluminum Retainers, Set of 8



## STOCK VALVE SPRING RETAINERS

Valve Spring Retainers have a hard life, having to withstand thousands of cycles per minute. It only makes sense to use new Retainers on every stock valve job. Sold in bulk, each.

**98-1964-B** Stock Valve Spring Retainers, 1200-1600cc, Bulk, Each  
(Ref. P/N: 113 109 641B)



## HI-PERFORMANCE STOCK 1.1:1 ROCKER KIT

Same quality Chromoly Rockers, high strength alloy shafts and stands as our 1.25 and 1.4 rockers in the 1.1:1 Stock Ratio. Rocker screws have M8-1.0 threads.

**17-2954** Hi-Performance Stock 1.1:1 Rocker Kit

(1/2 Assembled)



(1/2 Unassembled)



# ENGINE COMPONENTS

## EMPI HI-PERFORMANCE ROCKER SHAFT KITS

Increase the RPM potential of your engine and get more power. EMPI's rocker shaft kits help to eliminate rocker shaft side play that causes rocker arm galling, clip and washer failure. P/N: 21-2309 includes precision ground high strength shafts, with solid steel center spacer and shims. P/N: 21-2308 is similar to P/N: 21-2309 but has a floating aluminum center spacer which allows for "fine tuning" of rocker arm geometry and positioning. All necessary hardware is included. Best when used with EMPI's swivel foot adjusters.



21-2309

21-2309  
21-2308

EMPI Hi-Performance/High Strength Rocker Shaft Kit  
EMPI Hi-Performance Rocker Shaft Kit  
w/Floating Center Spacer



21-2308

## EMPI HIGH-RATIO FORGED ROCKERS

These superior quality chromoly rockers are just the answer for either a mild street or a hi-performance competition engine. EMPI's rocker arms are made from forged chromoly and then precision ground and heat treated. Not only are these the strongest rocker arms available, they are also drilled through on the alloy adjusting screws so both screws and rocker arms are fully lubricated. All shafts, blocks and shims are high strength alloy as well. Precision ground bronze bushings with through hole lubrication ensures that premature failure of the old needle bearing rocker arm design is a thing of the past. Chromoly rocker arm studs are provided to complete this kit and make installation and use a trouble free experience. Requires P/N: 4034 Cut-to Length Pushrods to set valve train geometry and achieve the correct pushrod length.



21-2162  
21-2164

EMPI 1.25 Forged Rocker Arms, w/Bushing, Set  
EMPI 1.40 Forged Rocker Arms, w/Bushing, Set

21-2170

Replacement Adjustment Screw Only, 5/16"-24 threads, Each

21-2166

**NEW!**

Rocker Shaft Shims Only, .030" Thickness, Set of 8

21-2167

**NEW!**

Rocker Shaft Shims Only, .015" Thickness, Set of 8

21-2168

**NEW!**

Rocker Shaft Shims Only, .010" Thickness, Set of 8



21-2168

**NEW!**

## 1.25 RATIO FORGED ROCKER ARMS

Forged for strength and durability, these ratio rocker arms provide an easy and inexpensive way to get more power and acceleration from any 1200-1600cc engine. No special modifications are needed, the 1.25's work with stock rocker shafts, push rods and adjusters or with our hi-performance shafts and swivel foot adjusters. The 1.25 Rocker Arms will not affect cam duration, bottom end performance or reliability and can be run with stock carburetors. They are quick and easy to install.



21-2312

21-2312  
21-2313

1.25 Ratio Forged Rocker Arms, Set of 8  
O.E. Type Valve Adjusting Screw/Nut Kit, M8-1.0 threads, Set of 8



21-2313



## CHROMOLY ROCKER STUDS

Chromoly Rocker Studs are superior in strength to stock studs. A must have for hi-performance heads with dual valve springs. Installs without modification in Type 1/2/3 1500-1600cc based heads. Sold in sets of 4.

21-2314 Chromoly Rocker Studs, Set of 4



## HEAVY DUTY PERFORMANCE SWIVEL VALVE ADJUSTERS

EMPI Heavy Duty Performance Swivel Feet Adjusters feature a large foot print that covers the valve stem to reduce the chance of mushrooming and side load friction. Contact areas are precision ground and hardened. Features slotted screw head design. Kit is complete with rocker stand shims to insure correct rocker arm geometry.

21-2031 H.D. Swivel Head Valve Adjusters, M8-1.0 threads, Set of 8



## BALL FOOT SWIVEL VALVE ADJUSTERS

Prevent valve stem wear caused by the side load of high lift cams and high valve spring pressure. A must for any hi-performance engine. Installation requires no special tools. Features slotted screw head design. Each kit includes rocker stand shims for correct height adjustment.

4061 Ball Foot Swivel Valve Adjusters, M8-1.0 threads, Set of 8



## VALVE ADJUSTMENT SCREW/NUT

98-0114-B M8 x 1.0 Valve Adjustment Screw, Type 1 50-79, Ghia 56-74, Type 2 50-71, Type 3 64-73, Each

(Ref. P/N: 043 109 451)

98-0112-B Nut for Valve Adjustment Screw, Type 1 50-79, Each

(Ref. P/N: N011 152 1)



## ROCKER ARM STAND SHIMS

Designed to go between the rocker stand and the head boss for correct rocker arm height and geometry. Available in 3 sizes (Thickness).

21-2315 Rocker Arm Shims, .015", Set of 4

21-2330 Rocker Arm Shims, .030", Set of 4

21-2360 Rocker Arm Shims, .060", Set of 4

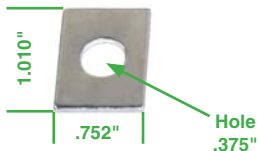

21-2310 Rocker Arm Shim Kit, 12 pcs. total  
Includes 4pcs. each of .015", .030", and .060"



## ROCKER SHAFT SHIMS

Replace the wave washers on the stock rocker shaft set-up. Eliminates excess side play and maintains proper valve train geometry. Each kit contains 8 shims and is available in 4 sizes (Thickness). These shims will work on 17-2954, 21-2308 and 21-2309.

4058 Rocker Shaft Shims, .010", Set of 8

4055 Rocker Shaft Shims, .015", Set of 8

4056 Rocker Shaft Shims, .030", Set of 8

4057 Rocker Shaft Shims, .060", Set of 8





## **EMPI HI-PERFORMANCE C-CHANNEL BOLT-ON VALVE COVERS**

Made from investment cast aluminum, with cast in EMPI logo and polished ribs on a black background. The finned design helps reduce upper cylinder head temperature and there is enough clearance for most high lift rocker arms. It also has a boss that can be drilled for venting to a breather box. The special C-Channel-Type seals and stud seals insure positive sealing. **Installation on 67 and prior Bugs may require trimming of the body for clearance.** Complete with all gaskets and hardware.

- 8852 "EMPI" Valve Cover Set
- 8868 Replacement Channel Gaskets, Pair
- 8897 Replacement Hardware Kit



## **BOLT-ON ALUMINUM VALVE COVERS**

These cast aluminum covers are great for Off-Road use, where the bale/clip type may come loose. The O-Ring stud seals prevent oil seepage. Cleared for use with hi-lift rockers. Use with stock cork/rubber gaskets, or with our high quality reusable neoprene gaskets. Complete with cork/rubber gaskets and hardware.

- 9152 Bolt-On Aluminum Valve Cover Set
- 9086 Replacement Hardware Kit
- 9087 Replacement O-Ring Seals Only, Set of 4
- 9088 Neoprene Valve Cover Gaskets, Pair
- 9907 Stock Style Cork/Rubber Valve Cover Gaskets, Pair  
(Bulk P/N: 113 101 481F, Each)



## **CLIP-ON ALUMINUM VALVE COVERS**

Cast and polished aluminum with cool fins to increase heat dissipation from the upper head area. Includes chrome bales/clips and cork/rubber gaskets.

- 9138 Clip-On Aluminum Valve Cover Set
- 9089 Replacement Chrome Bales/Clips, Pair
- 9088 Neoprene Valve Cover Gaskets, Pair
- 9907 Stock Style Cork/Rubber Valve Cover Gaskets, Pair  
(Bulk P/N: 113 101 481F, Each)



## **STOCK STYLE VALVE COVERS**

Made from heavy duty stamped steel, and available in chrome. Complete with bales, clips and cork/rubber gaskets.

- 8905 Chrome Stock Style Valve Covers, Set
- 8906 Replacement Chrome Bale/Clips, Pair





**NEW!**

## EMPI "GT" C-CHANNEL BOLT-ON VALVE COVERS

What's old is new again...New EMPI "GT" Valve covers featuring high polished fins and sides with black matte center, deeper bosses for breather vent fittings, and internal gussetting for strength. Enough clearance for most high lift rocker arms. Special C-Channel-Type seals and stud seals insure positive sealing. **Installation on 67 and prior Bugs may require trimming of the body for clearance.** Complete with all gaskets and hardware.

**8854** **NEW!** EMPI "GT" Valve Cover Set



**BUGPACK**  
**NEW!**

## BUGPACK RACING VALVE COVERS

The strongest aluminum valve cover model on the market just got better! We have re-tooled our original valve cover to allow even more clearance for high lift rocker arms while still maintaining the superior strength these valve covers are known for. Comes with a cast-in boss for vents. Complete with cork/rubber gaskets and hardware.

**B450200** **NEW!** BUGPACK Racing Valve Covers, Pair



## EMPI STAINLESS STEEL VALVE COVERS

Stamped stainless steel then polished to high luster. EMPI stamped into the valve cover. Cleared for use with most Hi-Lift Rockers. Includes chrome bales and cork/rubber gaskets.

**16-9470** **NEW!** EMPI Stainless Valve Cover, w/Bales, Pair  
**16-9468** Chrome Bales for P/N:16-9470, Pair

**9088** Neoprene Valve Cover Gaskets, Pair  
**9907** Stock Style Cork/Rubber Valve Cover Gaskets, Pair  
(Bulk P/N: 113 101 481F, Each)



**NEW!**



Lip



# ENGINE COMPONENTS

## **EMPI BOLT ON ALUMINUM VALVE COVERS FOR 1700-2000cc**

These polished Aluminum Bolt-On Valve Covers fit Type 2/4 1700-2000cc engines. The finned design aids heat dissipation and they look great. Complete with all gaskets and hardware. Uses stock gaskets.

- 8855** 1700-2000cc Bolt-On Aluminum Valve Cover Set
- 98-0148** Replacement Valve Cover Gasket, Pair
- (Bulk P/N: 021 101 481, Each)



8855

## **VALVE COVER GASKETS**

Choose from stock style cork/rubber or high quality re-usable neoprene. Sold in pairs.

- 9088** Neoprene Valve Cover Gaskets, Pair
- 9907** Stock Style Cork/Rubber Valve Cover Gaskets, Pair
- (Bulk P/N: 113 101 481F, Each)



9088

## **EMPI CAST ALUMINUM OIL BREATHER KIT**

Reduce crankcase pressure, eliminate blow-by and oil loss. High revving modified engines require more crankcase ventilation than the stock breather can supply. With the EMPI Aluminum Oil Breather Kit the blow-by oil is collected in the foam filter and the air vapors are vented to the atmosphere. New features include the EMPI logo cast in the top, improved heavy duty breather hose, plus internal changes that includes a screen mesh shelf to elevate the foam filter element.

- 8544** Complete Engine Oil Breather Kit
- 9242** Replacement Hose, Black (8 Feet)



8544

## **VALVE COVER VENTS**

Decrease crankcase pressure, eliminate blow-by and reduce oil loss with these easy to install Valve Cover Vents. Features our Sure Seal O-Ring system. Vent into air cleaner or a breather box.

- 9164** Valve Cover Vents, Pair





## EMPI HI-PERFORMANCE CAMSHAFTS

Street & Race-Proven profiles designed and manufactured for maximum performance and reliability. We start with a select Chilled Cast Iron Billet. Each camshaft is then machined and ground completely on CNC equipment, delivering exacting tolerances and repeatability. Select the appropriate cam for your application and install using new Cam Lifters. Each cam is supplied with a tube of assembly lube. Requires purchase of Cam Lifters, Gear and Bolts.



ZDDP or ZDTP should be either in the oil that you chose or added to the oil you chose when running any flat tappet camshaft.

The level of ZDDP has been reduced in the API SM oil spec, along with the increased use of calcium detergents and dispersants resulting in failures for flat tappet camshaft applications.

Many articles in all variety of magazines have been written on this subject.

Application	Part #	Lift (1.1)	Duration	Cam Lift	Dur. @ .050	Lobe Center
<b>EMPI CAMS WITH GRINDS FOR 1.1 OR 1.25 RATIO ROCKERS</b>						
Street/Dune Buggy	22-4100	.420"	276	.383"	236	108
Hot Street/Off-Road	22-4110	.430"	284	.392"	247	108
Hot Street/Off-Road Comp.	22-4120	.435"	294	.397"	253	108
Drag/Off-Road Comp.	22-4125	.460"	301	.418"	262	108
Drag/Off-Road Comp.	22-4130	.460"	308	.419"	267	108
Comp. Drag/Off-Road	22-4140	.465"	313	.424"	274	108

Application	Part #	Lift (1.1)	Duration	Cam Lift	Dur. @ .050	Lobe Center
<b>EMPI CAMS WITH HIGH LIFT GRINDS FOR 1.1 RATIO ROCKERS</b>						
Small Disp./Off-Road Comp.	22-4014	.462"	274	.420"	242	108
Med. Disp./Off-Road Comp.	22-4015	.478"	279	.435"	250	108
Midget/Crc. Trk./Off-Road	22-4025	.470"	286	.429"	256	108
Comp. Drag Only/Off-Road	22-4030	.507"	298	.461"	262	108
Comp. Drag Only/Off-Road	22-4035	.490"	309	.448"	278	108

Application	Part #	Lift (1.1)	Duration	Cam Lift	Dur. @ .050	Lobe Center
<b>EMPI TURBO GRIND CAMS FOR 1.1 ONLY RATIO ROCKERS</b>						
Street/Strip/Low Comp. Eng.	22-4210	.430/.420"	284/276	.392/.383"	247/236	112/112
Comp. Drag Only/Lg. Disp. Eng.	22-4220	.435/.430"	294/284	.397/.392"	253/247	112/112
Comp. Drag Only/Lg. Disp. Eng.	22-4230	.460/.435"	308/294	.419/.397"	267/253	112/112

Application	Part #	Lift (1.1)	Duration	Cam Lift	Dur. @ .050	Lobe Center
<b>EMPI CAMS WITH HIGH LIFT GRINDS FOR 1.4 TO 1.5 ROCKERS (LIFT BASED ON 1.4)</b>						
Med. Disp./Off-Road Comp.	22-4007	.500"	288	.357"	244	108
Street/Strip/Large Disp. Eng.	22-4008	.534"	298	.382"	258	108
Comp. Drag/Off-Road	22-4010	.539"	310	.385"	266	108
Street/Strip/Large Disp. Eng.	22-4013	.536"	281	.383"	250	108
Med. Disp./Off-Road Comp.	22-4065	.478"	280	.342"	236	108
Comp. Drag/Off-Road	22-4087	.561"	320	.401"	276	108
Comp. Drag Only/Off-Road	22-4089	.582"	328	.416"	282	108
Comp. Drag Only/Off-Road	22-4097	.622"	328	.443"	287	108
Comp. Drag Only/Off-Road	22-4098	.624"	332	.446"	291	108

Application	Part #	Lift (1.1)	Duration	Cam Lift	Dur. @ .050	Lobe Center
<b>EMPI CAMS WITH HIGH LIFT GRINDS FOR 1.4 TO 1.5 ROCKERS (LIFT BASED ON 1.4)</b>						
Bottom/Mid. Powerband	22-4041	.510"	269	.364"	239	108
Med. Disp./Hot Street/Off Road	22-4042	.522"	275	.373"	245	108
Off-Road/Drag Comp. Only	22-4044	.547"	287	.391"	256	108
Off-Road/Drag Comp. Only	22-4045	.561"	295	.401"	263	108
Off-Road/Drag Comp. Only	22-4046	.571"	301	.408"	268	108
Off-Road/Drag Comp. Only	22-4047	.587"	308	.419"	276	108





# ENGINE COMPONENTS

## EMPI HI-PERFORMANCE CAMSHAFT KITS

Kits come with EMPI Cam, EMPI Cam Gear, Bolts, Lifters, and Lube.

- The **23 Series** comes with Billet 28mm 1-PC Performance Lifters without an Oil Hole.
- The **24 Series** comes with Billet 28mm 1-PC Performance Lifters with an Oil Hole.

ZDDP or ZDTP should be either in the oil that you chose or added to the oil you chose when running any flat tappet camshaft.

The level of ZDDP has been reduced in the API SM oil spec, along with the increased use of calcium detergents and dispersants resulting in failures for flat tappet camshaft applications.

Many articles in all variety of magazines have been written on this subject.



Application	Part #	Lift (1.1)	Duration	Cam Lift	Dur. @ .050	Lobe Center
<b>EMPI 23 SERIES CAM KITS WITH 21-4300 LIFTERS</b>						
Street/Dune Buggy	<b>23-4100</b>	.420"	276	.383"	236	108
Hot Street/Off-Road	<b>23-4110</b>	.430"	284	.392"	247	108
Hot Street/Off-Road Comp.	<b>23-4120</b>	.435"	294	.397"	253	108
Drag/Off-Road Comp.	<b>23-4125</b>	.460"	301	.418"	262	108
Small Disp./Off-Road Comp.	<b>23-4014</b>	.462"	274	.420"	242	108
Med. Disp./Off-Road Comp.	<b>23-4015</b>	.478"	279	.435"	250	108

Application	Part #	Lift (1.1)	Duration	Cam Lift	Dur. @ .050	Lobe Center
<b>EMPI 24 SERIES CAM KITS WITH 21-4304 LIFTERS W/ OIL HOLE</b>						
Street/Dune Buggy	<b>24-4100</b>	.420"	276	.383"	236	108
Hot Street/Off-Road	<b>24-4110</b>	.430"	284	.392"	247	108
Hot Street/Off-Road Comp.	<b>24-4120</b>	.435"	294	.397"	253	108
Drag/Off-Road Comp.	<b>24-4125</b>	.460"	301	.418"	262	108
Small Disp./Off-Road Comp.	<b>24-4014</b>	.462"	274	.420"	242	108
Med. Disp./Off-Road Comp.	<b>24-4015</b>	.478"	279	.435"	250	108

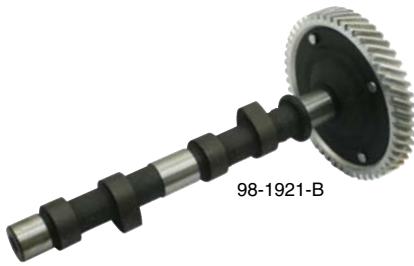

98-1921-B

## STOCK REPLACEMENT CAMSHAFTS

Brand new Stock Replacement Camshaft is available in both Early Flat Gear and Late Dished Gear Designs.

Remember, new cam lifters must be used with a new Cam.

**98-1920-B** Stock Cam w/Flat Gear, 1300-1600cc, 66-70  
(Ref. P/N: 113 109 021D)

**98-1921-B** Stock Cam w/Dished Gear, 1600cc, 71-79  
(Ref. P/N: 113 109 021G)



## EMPI STRAIGHT CUT ADJUSTABLE CAM GEAR SET

Steel cam and crank gear set with straight cut teeth creates less drag for increased horsepower. This design reduces thrust load on the cam bearings preventing premature failure. Cam timing is adjustable with the special offset washers. Manufactured from 8620 Carbon Steel for superior strength along with a lightweight cam gear design makes this the ultimate cam gear set to use. Kit includes 5/16" - 24 SAE Grade 8 bolts and washers for easy installation. Fits all 1200-1600cc Type 1/2/3.

**21-2515** Straight Cut Cam/Crank Gear Set



## ADJUSTABLE CAM GEAR KIT

Allows you to easily dial in your cam timing with the offset washers. The gear is precision machined from high quality aluminum and the kit includes special washers and 5/16" - 24 SAE Grade 8 bolts. Fits all 1200-1600cc Type 1/2/3.

**21-2510** Adjustable [Aluminum](#) Cam Gear Kit



## BOLT-ON CAM GEAR

Our Bolt-On Aluminum Cam Gear is made from high quality aluminum and precision machined for trouble free valve train performance. Works with all aftermarket and O.E. camshafts. Use our high grade cam gear bolts to attach gear to cam.

**21-2500** Bolt-On [Aluminum](#) Cam Gear



## CAM GEAR BOLTS

High Grade 5/16" - 24 SAE Grade 8 bolts with washer attached, for aftermarket cams. Use these bolts to attach our P/N: 21-2500 Cam Gear.

**21-4310** Cam Gear Bolts, Set of 3



**NEW!**

21-4315

## LOW PROFILE CAM BOLTS

These Low Profile 5/16"-24 SAE Grade 8 Cam Bolts offer a reduced head thickness for extra clearance when installing a 3-Bolt Cam & Gear with some Hi-Performance oil pumps.

**21-4315** **NEW!** Low Profile Cam Bolts, Set



# ENGINE COMPONENTS

## EMPI 28MM LIGHTWEIGHT PERFORMANCE LIFTERS

Precision ground and heat treated. In addition this lifter is available with an oil hole in the face for extra lubrication for those high load, hi-performance applications. Weigh only 3.2 oz each.

- 21-4300 1-Piece Lifters, 28mm, w/o Oil Hole, Set of 8  
(Bulk P/N: 113 109 309C)
- 21-4304 1-Piece Lifters, 28mm, w/Oil Hole, Set of 8



## EMPI 29MM ULTRA-LIGHTWEIGHT LIFTERS

1-Piece Ultra-Lightweight lifters – only 2.6 oz. each, .8 oz. less than a stock lifter. Precision Ground, heat treated with an oil hole in the face for extra lubrication. Push rod cup surface is Chromoly.

- 21-4307 EMPI Ultra-Lightweight Lifters, Set of 8



## EMPI 30MM LIGHTWEIGHT RACING LIFTERS

These lifters offer the same features as our 28mm face area lifters, above. With the addition of a 30mm face allowing for full contact when used with higher lift cam profiles these lifters can fill the needs of any racer! Weigh only 3.3 oz each.

- 21-4305 1-Piece Lifters, 30mm, w/Oil Hole, Set of 8
- 21-4306 1-Piece Lifters, 30mm, w/o Oil Hole, Set of 8



## 31MM HI-PERFORMANCE CAM LIFTERS

EMPI's 31mm surface contact lifters have 15% more contact area than stock lifters to reduce scuffing and early lobe wear. Precision ground. Sold in matched sets of 8. Weigh only 3.4 oz each.

- 21-4302 31mm Performance Cam Lifters, w/Oil Hole, Set of 8



## MOLY ASSEMBLY LUBE

Applied to all bearing surfaces, cam and cam followers during assembly, this high grade moly lube insures proper lubrication upon initial engine start up and run in.

- 27-0160 **NEW!** Moly Assembly Lube, 1/4 oz. Tube



## EMPI HI-PERF. ALUMINUM PUSH ROD TUBES

These billet aluminum machine finish push rod tubes have been designed to the specific requirements of hi-performance engine building. Features include two piece spring tensioned tubing that expands and contracts with engine, dual o-ring seals between the tubes, stock type end seals, plus they have an inner tube diameter of 7/8" at the head end for maximum push rod clearance. Aluminum tube can be shortened for narrower engine applications.

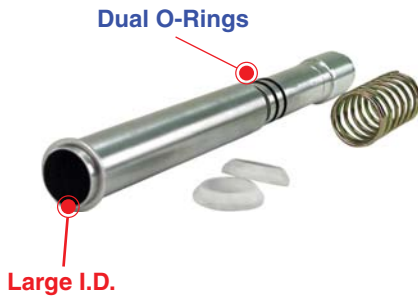

- 4108 EMPI Hi-Performance Aluminum Push Rod Tubes, Each
- 4109 EMPI Hi-Performance Aluminum Push Rod Tubes, Set of 8
- 4110 Replacement O-Ring Set for P/N: 4108/4109, 16 pcs.

## ADJUSTABLE ALUMINUM PUSH ROD TUBES

Change damaged or leaking push rod tubes in minutes without removing the engine or heads. Great for emergency repairs or permanent installation. The center o-ring seal stops oil leaks. Made from heavy duty aluminum for strength and anodized for good looks. Fits 1200-1600cc.



- 9139 Adjustable Push Rod Tube w/Seals, Each
- 9139-7 Adjustable Push Rod Tube w/o Seals, Each
- 9149 Adjustable Push Rod Tube w/o Seals, Set of 8
- 9038 Replacement O-Ring, Set of 8

## ALUMINUM QUICK CHANGE PUSH ROD TUBES

The spring loaded design also allows you to quickly change damaged or leaking push rod tubes with the engine in the car. The heavy duty spring keeps a constant tension for a positive seal. Made from heavy duty aluminum and fully blue anodized for good looks and protection from the elements. Fits 1200-1600cc.



- 9095 Quick Change Push Rod Tube w/Seals, Each
- 9096 Quick Change Push Rod Tube w/Seals, Set of 8

## NYLON SELF-ADJUSTING PUSH ROD TUBES

The heat resistant high impact design nylon is an economical alternative to the aluminum self-adjusting push rod tube and offers the same benefits (Black). Fits all 1200-1600cc.



- 9159 Nylon Push Rod Tube w/Seals, Set of 8
- 9159-7 Nylon Push Rod Tube w/o Seals, Set of 8
- 9160 Nylon Push Rod Tube w/Seals, Each
- 9160-B Bulk Nylon Push Rod Tube w/o Seals, Each  
(Ref. P/N: 311 109 335 ADJ)



## STAINLESS STEEL WINDAGE PUSH ROD TUBES

Get your oil under control. Windage Push Rod Tubes extend further into the case to prevent oil from over filling the valve covers during cornering, side hilling in the dunes, or hard race use. Made from stainless steel to resist corrosion. Fits all 1300-1600cc.

- 8530**                      [Stainless](#) Windage Push Rod Tubes, w/o Seals, Each
- 8531**                      [Stainless](#) Windage Push Rod Tubes, w/o Seals, Set of 8
- 8530-B**                 Bulk [Stainless](#) Windage Push Rod Tubes, w/o Seals, Each



## STAINLESS STEEL PUSH ROD TUBES

No rust or corrosion with EMPI Stainless Steel Push Rod Tubes. The ultimate in strength and good looks. Fits all 1300-1600cc.

- 8520**                      [Stainless](#) Push Rod Tube w/o Seals, Each
- 8521**                      [Stainless](#) Push Rod Tube w/o Seals, Set of 8
- 8520-B**                 Bulk [Stainless](#) Push Rod Tube w/o Seals, Each



## STOCK STYLE PUSH ROD TUBES

Replacement quality stock style push rod tubes. Ideal for stock engine builds and rebuilds. Fits all 1300 - 1600cc.

- 8522-1**                 Bulk Stock Style Push Rod Tube, Raw, Each  
(Ref. P/N: 311 109 335)



## PUSH ROD TUBE SEALS

Choose from High Temperature Silicone or Stock replacement seals. The High Temperature Silicone Push Rod Tube Seals will hold up to high heat without drying and cracking. Each kit contains 16 seals. Enough for one complete engine.

- 9153**                      [Silicone](#) Push Rod Tube Seal Kit, 16 pcs.  
(Bulk P/N: 113 109 345AS, Bag of 100)
- 9150**                      Stock Push Rod Tube Seal Kit, 16 pcs.  
(Bulk P/N: 113 109 345A, Bag of 100)



9150



9153



## EMPI HEAVY DUTY OIL PUMPS

The gears on the EMPI H.D. Oil Pump are 38% larger than stock pumps; providing increased oil pressure, oil flow, volume and lower oil temperature. Made from cast iron and precision machined for a distortion free fit. The early style P/N: 31-2935 pump is compatible with stock and hi-performance cams with flat cam gears. Complete with gasket and studs.

- 31-2935** 1300-1500cc, thru 70, 30mm Gears, 8mm Studs, w/Flat Cam Gear
- 31-2925** 1600cc, from 71, 34mm Gears, 8mm Studs, w/Dish Cam Gear



## MELLING HEAVY DUTY OIL PUMPS

The Melling H.D. Oil Pump is made from cast iron and has gears that are 38% larger than stock. Genuine Melling with 30mm gears. Complete with gasket and studs.

- 31-2955** 1300-1500cc, thru 70, 8mm Studs, w/Flat Cam Gear

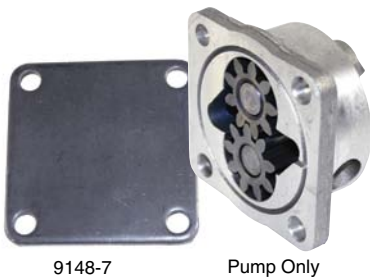

## STOCK STYLE HEAVY DUTY OIL PUMPS

For stock and moderate hi-performance engines. Oil volume is increased. Made from cast aluminum and machined to exacting tolerances. These pumps have 30mm gears. Pumps are supplied without cover, use P/N: 9148-7 cover. All Pumps are for 8mm studs.

- 111 115 107AHP**    **98-1158-B**    H.D. Oil Pump, w/Flat Cam Gear, 30mm Gears, 1500-1600cc, thru 70
- 111 115 107BHD**    **98-1159-B**    H.D. Oil Pump, w/Dish Cam Gear, 30mm Gears, 1600cc, from 71
- 9148-7**    Oil Pump Cover Only, Stock Style

## FULL FLOW FILTER PUMPS

These high capacity (32mm gears) pumps provide added oil pressure, increased oil volume and oil cooling. The filter cleans the oil 100% of the time. Kit includes filter and all necessary hardware. (Will not fit with stock muffler or P/N 3417).

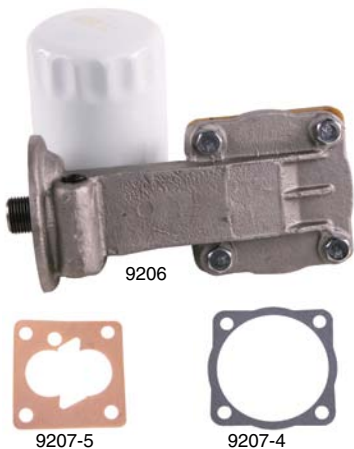

- 9206**    Pump w/Filter, 1300-1600cc, thru 70, w/Flat Cam Gear, Includes 6 & 8mm Bolts
- 9206-7**    Pump Only, 1300-1600cc, thru 70, w/Flat Cam Gear, Includes 6 & 8mm Bolts
- 9207**    Pump w/Filter, 1600cc, from 71, w/Dish Cam Gear, Includes 8mm Bolts
- 9207-7**    Pump Only, 1600cc, from 71, w/Dish Cam Gear, Includes 8mm Bolts
- 9208**    Replacement Oil Filter
- 9286**    Replacement 6mm Mounting Bolts, Set of 4
- 9287**    Replacement 8mm Mounting Bolts, Set of 4
- 9207-5**    Replacement Gasket between the Cover and Pump, Each
- 9207-4**    Replacement Gasket between Pump and Engine Case, Each

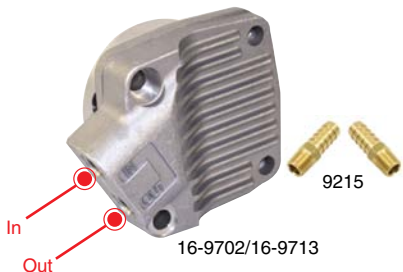

## FILTER FLOW OIL PUMP

Add a conventional oil filter to your engine with this 32mm gear oil pump with 1/4" NPT tapped inlet and outlet. Supplied with Hardware and Gasket. Use P/N 9215 fittings.

- 16-9702**    Filter Flow Oil Pump, thru 70, w/Flat Cam Gear, Each
- 16-9713**    Filter Flow Oil Pump, 71 & Later w/Dish Cam Gear, Each
- 9215**    1/4" Male NPT w/ 1/2" Hose Barb, Pack of 2



# OIL SYSTEM COMPONENTS

## H.D. CAST IRON FULL FLOW PUMP KIT

Made from Cast Iron, precision machined for maximum performance and distortion free fit. This Heavy Duty pump provides increased oil pressure, flow and volume. Packaged with our matching EMPI Steel Cover with a 3/8" NPT threaded boss, 8mm Allen Head Cap Screw Bolts and gaskets. For 71 & later, pump and engine case must be threaded and plugged. Plugs not included.

**16-9714** H.D. Cast Iron Full Flow Pump Kit, thru 70, 30mm Gears, Flat Cam Gear\*

\*Pump is Full-Flow Ready, without an exit passage port. No need to thread the Oil Pump! To be used with Full-Flow Pump Cover ONLY.

**16-9715** H.D. Cast Iron Full Flow Pump Kit, 71 & Later, 34mm Gears, Dish Cam Gear



## H.D. ALUMINUM FULL FLOW PUMP KITS

Precision machined from aluminum for maximum performance, these pumps feature high capacity 32mm gears— providing increased oil pressure, flow and volume. P/N 16-9716 and P/N 16-9717 are packaged with our matching EMPI Polished Billet Aluminum Cover with a 3/8NPT threaded boss, 8mm Allen Head Cap Screw Bolts and gaskets. P/N 16-9718 and P/N 16-9719 are packaged with our NEW EMPI P/N 17-2947 Polished Billet Aluminum Cover with a 3/8NPT threaded boss, 8mm Allen Head Cap Screw Bolts and gaskets. For 71 & later, pump and engine case must be threaded and plugged. Plugs not included.

**16-9716** Aluminum Full Flow Pump Kit, thru 70 Flat Cam Gear\*

\*Pump is Full-Flow Ready, without an exit passage port. No need to thread the Oil Pump! To be used with Full-Flow Pump Cover ONLY.

**16-9717** Aluminum Full Flow Pump Kit, 71 & Later, Dish Cam Gear

**16-9718** Aluminum Full Flow Pump Kit, thru 70. Flat Cam Gear\*

\*Pump is Full-Flow Ready, without an exit passage port. No need to thread the Oil Pump! To be used with Full-Flow Pump Cover ONLY.

**16-9719** Aluminum Full Flow Pump Kit, thru 71 & Later, Dish Cam Gear



## EMPI BILLET ALUMINUM OIL PUMP COVERS

With everything else being made from 6061-T6 aluminum it was only natural to offer our 8mm oil pump covers like that. These are available for both full flow and stock style applications. Fitting & gasket included with 31-2942. Gasket included with P/N 31-2943.

**31-2942** Billet Aluminum Oil Pump Cover, 8mm, Full Flow

**31-2943** Billet Aluminum Oil Pump Cover, 8mm, w/o Full Flow or Fitting



## BILLET ALUMINUM OIL PUMP COVER

Show quality Polished Billet Aluminum oil pump cover with 3/8NPT threaded boss for a full flow system...or plug it and use as a decorative cover. Supplied with 3/8NPT fitting and gasket

**17-2947** Billet Aluminum Oil Pump Cover



## OIL PUMP COVERS

Our precision fit oil pump covers are made with a threaded boss for use with full flow filter or cooler. Fits all VW pumps with 8mm bolt holes. Both P/N 31-2940 and P/N 9226 come complete with fitting and gasket. The stock style cover is made of steel and has 8mm bolt holes.

**9226** Oil Pump Cover w/Fitting and Gasket, Aluminum

**9148-7** Oil Pump Cover Only, Stock Style

**31-2940** Oil Pump Cover w/Fitting and Gasket, Steel



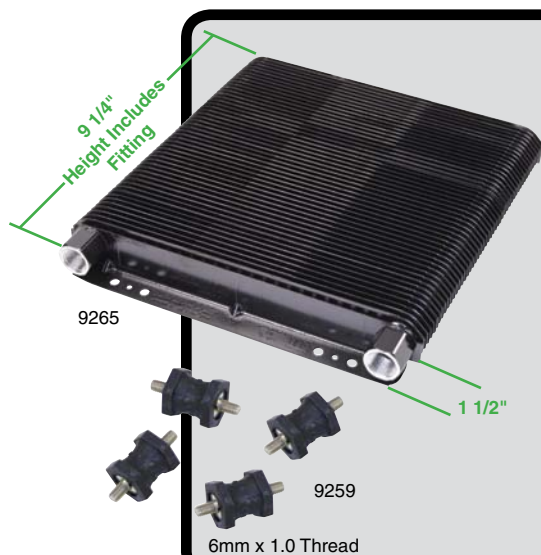

## EMPI COMPETITION ENGINE OIL COOLERS

The ultimate in cooling efficiency. The EMPI stacked-plate design offers maximum cooling with almost bulletproof strength. Aircraft quality aluminum, flux-less oven brazed construction. Cross-path airflow effectively cools oil as air passes through as many as 16 paths across sturdy embossed plates. Insignificant pressure drop with twice the cooling and half the size! Painted black for fast heat dissipation. **Fitted with 1/2" female pipe thread fittings. Mounting Dampers are recommended.** P/N: 9267 is supplied with 1 pair of metal brackets.

- 9267** 96-Plate Oil Cooler Only - 1 1/2" x 12" x 11"
- 9265** 72-Plate Oil Cooler Only - 1 1/2" x 9 1/4" x 11"
- 9271** 48-Plate Oil Cooler Only - 1 1/2" x 6 1/2" x 11"
- 9273** 24-Plate Oil Cooler Only - 1 1/2" x 3 3/4" x 11"

- 9259** Cooler Mounting Dampers, Set of 4
- 9259-7** Bulk Cooler Mounting Dampers, Each



## COMPETITION OIL COOLER KITS

Complete kit includes Oil cooler, Bypass Adapter, Remote Filter Bracket, High-Temperature Hose and all fittings required for installation. Fits all Type 1 and Type 2 thru 71.

- 9261** 96-Plate Oil Cooler Kit
- 9264** 72-Plate Oil Cooler Kit
- 9270** 48-Plate Oil Cooler Kit
- 9272** 24-Plate Oil Cooler Kit



## UNIVERSAL COMPETITION OIL COOLER KITS

Complete kits includes Cooler, Bypass or "Sandwich" Adapter with 3/4" x 16 Nipple, Remote Filter Bracket, High Temperature Hose and all fittings required for installation on your Type 4, Rabbit/Jetta and a host of other applications. The Bypass adapter is for remote mounting of the oil filter. The Sandwich Adapter fits between stock filter mount and filter.

### KITS WITH BYPASS ADAPTER

- 9262** 96-Plate Oil Cooler Kit w/Bypass Adapter
- 9263** 72-Plate Oil Cooler Kit w/Bypass Adapter
- 9294** 48-Plate Oil Cooler Kit w/Bypass Adapter
- 9295** 24-Plate Oil Cooler Kit w/Bypass Adapter

### KITS WITH SANDWICH ADAPTER

- 9218** 96-Plate Oil Cooler Kit w/Sandwich Adapter
- 9217** 72-Plate Oil Cooler Kit w/Sandwich Adapter
- 9278** 48-Plate Oil Cooler Kit w/Sandwich Adapter
- 9299** 24-Plate Oil Cooler Kit w/Sandwich Adapter







# OIL SYSTEM COMPONENTS

## EMPI HI-PERFORMANCE ENGINE OIL COOLERS

Features 1/2" copper tubing, aluminum cooling fins and mechanical expansion construction for maximum heat dissipation with the least amount of pressure drop. Available with 1/2" Male threaded ends or 1/2" Hose Barb ends. Skin packed cooler kits include oil pressure booster kit. Braided stainless steel lines can be used with the coolers that have 1/2" male threaded ends.

### 8-PASS OIL COOLERS & KITS

Complete kit includes Cooler, Bypass Adapter, Remote Filter Bracket, High Temperature Hose and all necessary fittings and hardware for installation on your VW. Fits all Type 1 and Type 2 thru 71. Available skin packed or boxed. Skin packed kits include oil pressure booster kit.

#### 1/2" MALE THREADED ENDS (NEW SPLIT FIN DESIGN)

- 9221 Skin Packed 8-Pass Oil Cooler Kit, 1/2" Male Thread, w/Dual Booster Kit
- 9232 Boxed 8-Pass Cooler Kit, 1/2" Male Thread, w/o Booster Kit
- 9241 8-Pass Cooler Only, 1/2" Male Threaded Fitting (Requires P/N: 9288 Fitting)

#### 1/2" HOSE BARB ENDS (NEW SPLIT FIN DESIGN)

- 9223 Skin Packed 8-Pass Oil Cooler Kit, 1/2" Hose Barb, w/Booster Kit
- 9233 Boxed 8-Pass Cooler Kit, 1/2" Hose Barb, w/o Booster Kit
- 9243 8-Pass Cooler Only, 1/2" Hose Barb

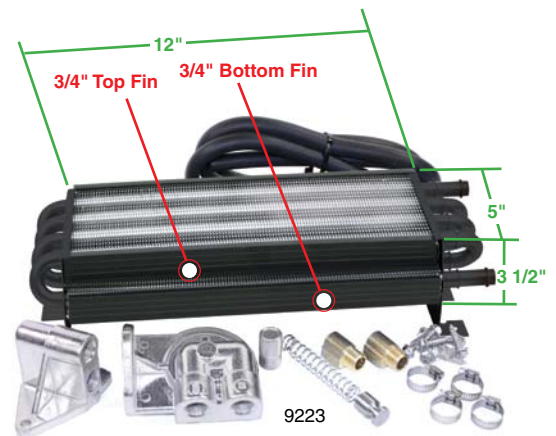

### 6-PASS OIL COOLERS & KITS

Complete kit includes 6-Pass Cooler, Bypass Adapter, Remote Filter Bracket, High Temperature Hose and all necessary fittings and hardware for installation on your VW. Fits all Type 1 and Type 2 thru 71. Available skin packed or boxed. Skin packed kits include oil pressure booster kit.

- 9276 Skin Packed 6-Pass Oil Cooler Kit, 1/2" Hose Barb, w/Booster Kit
- 9234 Boxed 6-Pass Cooler Kit, 1/2" Hose Barb, w/o Booster Kit
- 9277 6-Pass Oil Cooler Only, 1/2" Hose Barb



### UNIVERSAL 8-PASS OIL COOLER KITS

Complete kit includes everything you need for installation on your Type 4, Porsche 914, 924, Rabbit, Jetta, Dasher, Scirocco and many others. Your choice of Bypass or Sandwich Adapter. Cooler is fitted with 1/2" Male Fittings. The sandwich adapter fits between the stock filter mount and filter.

- 9291 Universal 8-Pass Oil Cooler Kit, w/Bypass Adapter
- 9285 Universal 8-Pass Oil Cooler Kit, w/Sandwich Adapter





## EMPI COMPETITION OIL COOLER & FAN KITS

This is really cool! EMPI's ultra rugged & efficient 72 and 96 stacked plate competition coolers just got better. They are now available with a 12V electric fan. Instructions and hardware for mounting fan to cooler are included. Use with an On/Off switch or with an electronic or inline thermostat for worry free operation.

**9292** 72 Plate Competition Oil Cooler & Fan Kit

**9293** 96 Plate Competition Oil Cooler & Fan Kit

**9259** Cooler Mounting Dampers, Set of 4  
**9259-7** Bulk Cooler Mounting Dampers, Each

9259  
6mm x 1.0 Thread



## REPLACEMENT FAN ONLY

9" replacement fan can also be used for custom applications. Patented skewed blade design results in high efficiency with lower noise. Can be run as a pusher or puller by simply reversing the fan blade assembly (570 max CFM at 5.4 AMPS).

**9296** Replacement Fan Only for P/N: 9292/9293



33-5721

## FAN THERMOSTAT

Put your cooler fan on autopilot with this Fan Thermostat (P/N 33-5721). No worries about cooking your engine because there are no more switches to remember to turn on or off. This Inline Thermostat attaches to the inlet port of the oil cooler or it can be spliced into existing 1/2" hose, and it activates at 180° F.

**33-5721** Inline Cooler Thermostat, -8AN 1/2" Hose Barb



## HI-PERFORMANCE FAN & COOLER KIT

A different version of our popular fan/cooler. Complete kit includes black powder coated 16-pass copper tube cooler with -8AN male fittings, 10" reversible electric fan and aluminum clear anodized mounting brackets. Two brass fittings are supplied if you want barbed ends.

**9290** Electric Fan & Cooler Kit



## BOLT-ON OIL COOLER FAN KIT

A complete full flow oil cooler system with fan without removing the engine. All the parts required to add a full flow oil system to your engine, without machining. Leaves original oil cooler in place. Includes: 96 Plate Oil Cooler (P/N 9267), 9" Fan, hose, thermostat, pump cover, oil filter bracket, oil return adapter and hardware. Oil pump and case must be threaded and plugged to complete full flow system.

*Fits Dual By-Pass Case Only.*

**9248** Bolt-On Oil Cooler Fan Kit, Each



# OIL SYSTEM COMPONENTS

## EMPI UNIVERSAL TRANSMISSION FLUID COOLERS

Same efficient and rugged stack-plate design as our EMPI competition engine oil coolers. These coolers feature 1/2" Female threaded ends with 3/8" hose barb fittings for easy installation. Kits come skin packed and include hose, 3/8" hose barb fittings, installation hardware and detailed instructions.

Cooler Only w/Fittings	Complete Kit	Size H x W x T	No. of Plates	Heat Rejection BTU/HR	GVW Rating
85-4002	85-4102	3 3/4 x 11 x 1 1/2	24	7,500	10,800
85-4003	85-4103	6 1/2 x 11 x 1 1/2	48	15,000	19,000
85-4004	85-4104	9 1/4 x 11 x 1 1/2	72	21,800	24,000
85-4005	85-4105	12 x 11 x 1 1/2	96	25,000	28,000

EMPI Transmission Coolers will fit any vehicle fitted with an Automatic Transmission where space permits. From your car's I.D. tag, find the gross vehicle weight (G.V.W.) and compare it to the G.V.W. column in the chart above. "Bigger is Better" is the rule of thumb as you can never over-cool a transmission. When in doubt, go to the next larger size. If you plan to tow a trailer or heavy load, install the largest cooler.

**Great for tow vehicles, RV's, etc...!**

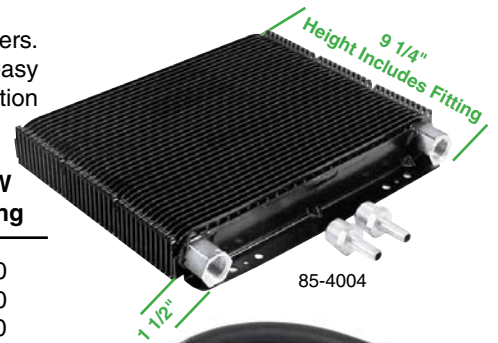

## HIGH TEMP / HIGH PRESSURE OIL HOSE

High Temperature / High Pressure Oil Hose for use with oil coolers and/or remote oil filter. This hose is made to work between -40° to 312° F with a working pressure of 300 PSI and a burst pressure of 1200 PSI. 3/8" and 1/2" ID available in different lengths.

### 3/8" I.D. (#6)

#### HI-TEMP/PRESSURE OIL HOSE

9209	5' length - Skinpacked
9279	25' Length - Boxed
9280	50' Length - Boxed

### 1/2" I.D. (#8)

#### HI-TEMP/PRESSURE OIL HOSE

9210	5' Length - Skinpacked
9282	25' Length - Boxed
9283	50' Length - Boxed
9284	100' Length - Boxed



## UNIVERSAL OIL FILTER & SANDWICH ADAPTERS

Can be used on a number of makes and models, including Type 4 and VW water-cooled models. Fitted with 3/4" x 16 Nipple and tapped for 3/8 NPT fittings.

9229	Universal Adapter w/Nipple, For Remote Filter (New Design)
9247	Universal Sandwich Adapter w/Special Male/Female Nipple



## BILLET OIL FILTER ADAPTER

Our Billet Oil Filter Adapter (spinner) comes with all necessary mounting hardware including 3/4" x 16 Nipple. Tapped 3/8" NPT. Easily accepts all PH8A style standard oil filters.

16-9513 **NEW!** Billet Oil Filter Adapter Kit



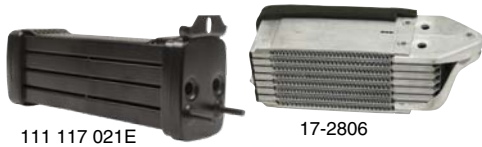

## STOCK REPLACEMENT OIL COOLER

Keep your cool by replacing that old, dirty, leaky Doghouse oil cooler with a brand new unit from EMPI. If you are converting from the early style cooler, you will need the adapter.



- 111 117 021E**      **98-1178-B**      Oil Cooler, Type 1 50-70, Ghia 56-70, Type 2 50-70  
*Aluminum Construction*
- 021 117 021B**      **17-2806**      Oil Cooler, Type 2/4,  
1700-2000cc / 914, 7 Plate (*Aluminum*)
- 113 117 021**      **98-1161-B**      Oil Cooler for 1300-1600cc  
w/Doghouse Shroud, 5 Plate (*Aluminum*)
- 8894**      Doghouse Oil Cooler to Case Adapter, for P/N 98-1161-B only  
(Ref. P/N: 113 117 303)



## DUAL BYPASS ADAPTER

This adapter allows you to run both your stock oil cooler PLUS an external cooler and/or remote filter. Fits Type 1 w/minimal trimming to sheet metal. Will not fit with 'Dog House' cooler.

- 17-2873**      Dual Bypass Adapter, Kit



## OIL COOLER & BYPASS SEALS

High quality replacement seals for use with stock oil cooler or with bypass adapter.

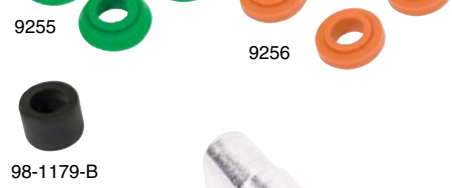

- 9255**      Oil Cooler Seals, 8/10mm, Pack of 4
- 9255-B**      Bulk Oil Cooler Seals, 8/10mm, Pack of 100  
(Ref. P/N: 111 117 151B)
- 98-1179-B**      Seal, Oil Cooler (For Cooler w/8mm Ports), Each,  
Type 1 50-70, Ghia 56-70, Type 2 50-70, Each  
(Ref. P/N: 111 117 151)
- 9256**      Oil Cooler Seals, 10mm Late, Pack of 4
- 9256-B**      Bulk Oil Cooler Seals, 10mm Late, Pack of 100  
(Ref. P/N: 021 117 151A)

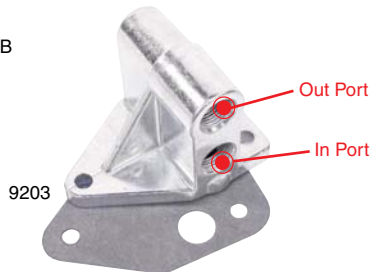

## OIL COOLER BYPASS

Replaces stock oil cooler allowing for use of external oil cooler. Eliminates air flow blockage to #3 and #4 cylinders. Includes mounting hardware and gasket. Tapped with 3/8" NPT.

**(Note: For reference; top is out and the bottom is in).**



- 9203**      Oil Cooler Bypass w/Gasket & Hardware
- 9266**      Replacement Gaskets, Pair

## BILLET ALUMINUM OIL COOLER BLOCK-OFF

Show quality Polished Billet Aluminum oil cooler block-off. Comes with Allen Head Cap Screws for a clean installation along with gasket and hardware.

- 17-2946**      *Billet Aluminum* Oil Cooler Block-Off



## OIL COOLER BLOCK-OFF

Blocks off oil passages for applications where "full-flow" oil system is used or when normal oil cooler is no longer needed. Tapped 1/4" NPT boss for oil pressure sender. Includes mounting hardware and gasket.

- 9146**      Oil Cooler Block-Off w/Gasket, Plug & Hardware
- 9266**      Replacement Gaskets, Pair



## OIL FILTER ADAPTERS

Mounts a standard Spin-On Oil Filter in the location of your choice. Adapters have 3/8" NPT female threads and supplied with 3/4 x 16 Nipple. Use P/N: 9240, 9250, 17-2920, 17-2921, or 17-2922 Spin-On Filters.

- 9244**      Oil Filter Adapter w/Nipple, Ports Left
- 9245**      Oil Filter Adapter w/Nipple, Ports Right
- 9204**      Oil Filter Adapter w/Nipple, Ports Up
- 9253**      Replacement Threaded Nipple



# OIL SYSTEM COMPONENTS

## REMOTE OIL FILTER MOUNTS

EMPI's Bolt-On Full Flow Oil Filter Mounts make filter mounting easy. Inward and outward polished aluminum exhaust flange mounts accommodate most off-road and drag race applications. While P/N: 16-8242 covers street sedan applications by cleanly tucking the filter up under the rear fender on a black powder coated steel mount that attaches with the bumper bracket bolts (Hardware included).

- 16-8240 Billet Inward Facing Exhaust Flange Oil Filter Mount
- 16-8241 Billet Outward Facing Exhaust Flange Oil Filter Mount
- 16-8242 Under Fender Oil Filter Mount, Type 1, thru 73



## BILLET FULL FLOW HOSE BRACKETS

Keep oil lines in check while maintaining that Billet Look. Bolts on at exhaust flange and helps protect oil lines from engine and exhaust. Fits up to 3/4" O.D. Hose.

- 17-2809 Billet F/F Oil Line Bracket – Black, Each
- 17-2810 Billet F/F Oil Line Bracket – Polished, Each



## OIL THERMOSTAT

Mounts in-line and bypasses oil cooler until oil warms up to approximately 175 degrees. Always partially open to avoid over pressurizing. A must in performance and cold-weather applications. Kit comes complete with fittings and clamps.

- 33-5000 Oil Thermostat Only w/ 3/8" NPT
- 33-5010 Oil Thermostat w/Fittings & Clamps



## EMPI HIGH PRESSURE OIL FILTER

If you are running higher pressure oil pumps, or have problems with mushrooming and exploding filters, you need a High Pressure Oil Filter. Manufactured with a heavy-duty steel walled canister and double bypass valves to control extreme pressures without expanding or splitting. The 3/4"-16 threads fit most remote oil filter mounts and adapters. Fits P/N: 9204, 9244, 9245 and 16-9513 oil filter adapters. Available in chrome.

- 9250 High Pressure Oil Filter, Skinpacked
- 9240 Chrome High Pressure Oil Filter, Skinpacked



## FRAM OIL FILTERS

For those who insist on the best- FRAM filters with Advanced Engine Protection uses cellulose and synthetic glass fiber blended media to provide 3X MORE engine protection than the average of leading economy oil filters with 95% Dirt Trapping Efficiency. Fits P/N: 9204, 9244, 9245 and 16-9513 oil filter adapters.

- 17-2920 PH8A FRAM Filter
- 17-2921 HP1 FRAM Filter
- 17-2922 HP3 FRAM Filter



## OIL SYSTEM FITTINGS & CLAMPS

Fittings, Hose Barbs, Swivels, Bushings, Clamps...Everything you'll need to plumb your oil system.



- 9205** Brass T Fitting/Adapter (1/8"), For Gauges, Each
- 9211** 3/8" Male w/ 3/8" Hose Barb, Pack of 2
- 9212** 3/8" Male w/ 1/2" Hose Barb, Pack of 2
- 9213** 1/2" Male w/ 3/8" Hose Barb, Pack of 2
- 9214** 1/2" Male w/ 1/2" Hose Barb, Pack of 2
- 9215** 1/4" Male w/ 1/2" Hose Barb, Pack of 2
- 17-2876** 30° 3/8" Male w/ 1/2" Hose Barb, Pack of 2
- 9227** 90° 3/8" Male x 3/8" Female, Pack of 2
- 9239** 90° 1/2" Male x 1/2" Female, Pack of 2
- 9237** 45° 3/8" Male x 3/8" Female, Pack of 2
- 9288** 1/2" Female Swivel x 1/2" Hose Barb, Pack of 2
- 9246** Converts #8AN Male to 1/2" Hose Barb
- 9225** 45° 1/4" Male X 1/4" Female, Pack of 2



## OIL RETURN ADAPTER KIT

Designed to add a full flow oil system without machining the crankcase. Screws into the rear oil by-pass galley (spring & plunger must be removed) and provides the return route for oil from a full flow pump cover. Installs without engine removal. It has an 8AN male fitting. This can be converted to a 1/2" barb with EMPI P/N: 9288 Fitting. **Fits Dual By-Pass Case Only.**



- 16-9517** Oil Return Adapter Kit, Each

## OIL PRESSURE BOOSTER KIT

Specially designed larger piston and stronger spring increase oil pressure throughout the system. A must when installing an oil cooler or remote filter.

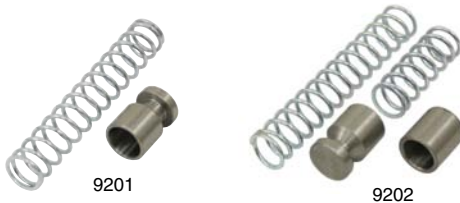

- 9201** Single Oil Booster Kit, thru 69
- 9202** Dual Oil Booster Kit, From 70

## ADJUSTABLE OIL PRESSURE REGULATOR

Allows you to adjust the oil pressure with the twist of a wrench. Use with stock pressure regulator spring.



- 9198** Adjustable Oil Pressure Regulator Kit, Each

## OIL PRESSURE SWITCH

This is one of the least expensive - most important parts of your engine. Don't "hope" your old switch is working - be sure with a new switch.



- 98-9190** Oil Pressure Switch, for Stock Indicator Light (Bulk P/N: 021 919 081B)

## THREAD SEALING TAPE

A must to seal all threaded fittings and joints. Use on oil and fuel line fittings.



- 9231** PTFE Thread Sealing Tape, Roll



# OIL SYSTEM COMPONENTS

## BRAIDED STAINLESS LINE

Good looks and reliability. Give your VW that 200 MPH look with Braided Stainless line. 3/8" and 1/2" for Oil and breather lines. Sold in 3 different lengths. Not to be used on High Performance Engines.

3/8" I.D. (#6) BRAIDED STAINLESS LINE		1/2" I.D. (#8) BRAIDED STAINLESS LINE	
8815	5' Length - Skinpacked	8820	5' Length - Skinpacked
8816	10' Length - Skinpacked	8821	10' Length - Skinpacked
8817	25' Length - Boxed	8822	25' Length - Boxed



## HIGH TEMP / HIGH PRESSURE OIL HOSE

High Temperature / High Pressure Oil Hose for use with oil coolers and/or remote oil filter. This hose is made to work between -40° to 312° F with a working pressure of 300 PSI and a burst pressure of 1200 PSI. 3/8" and 1/2" ID available in different lengths.

3/8" I.D. (#6) HI-TEMP/PRESSURE OIL HOSE		1/2" I.D. (#8) HI-TEMP/PRESSURE OIL HOSE	
9209	5' length - Skinpacked	9210	5' Length - Skinpacked
9279	25' Length - Boxed	9282	25' Length - Boxed
9280	50' Length - Boxed	9283	50' Length - Boxed
		9284	100' Length - Boxed



## HIGH CAPACITY OIL SUMP

Increase oil supply and prevent oil starvation by adding 1 1/2 quarts of oil capacity with EMPI's High Capacity Oil Sump. The cast finned design also increases cooling. Includes all necessary hardware and 3 sizes of pick-up tubes for all 1200-1600cc engine types. All 3 variations of oil screens fit this sump.

9142	1.5 Qt High Capacity Oil Sump
------	-------------------------------

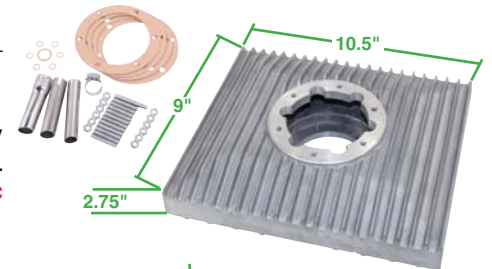

## EMPI SUPER CAPACITY OIL SUMP

Oil takes a lot of abuse in an air-cooled engine. It has to provide both lubrication and cooling functions, therefore any type of performance upgrades or demanding driving requires additional oil capacity. EMPI's thin line sump increases oil capacity by 3.5 quarts without the loss of ground clearance associated with other super capacity sumps. Includes all necessary hardware and 3 sizes of pick-up tubes for all 1200-1600cc engine types. All 3 variations of oil screens fit this sump.

9143	3.5 Qt. Thin Line Super Capacity Oil Sump
------	---

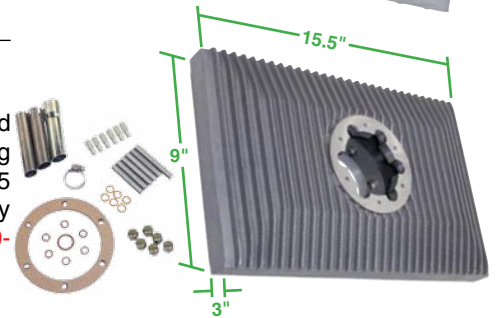

## OIL SUMP W/FILTER (Narrow)

Cast aluminum oil sump is only 1 3/4" deep. Adds oil capacity and offers improved filtration and easy bolt-on installation. Filter design allows for unimpeded oil flow even if the filter gets plugged. Stainless Steel Micron Filter can be cleaned and reused. 1 Qt. Capacity. Now tapped and supplied with magnetic drain plug. Includes all necessary hardware.

17-2871	Narrow Sump w/Filter Kit, Each
17-2874	Replacement Filter for P/N 17-2871/17-2872, Each
17-2877	Replacement Drain Plate Gasket Only (Bulk)



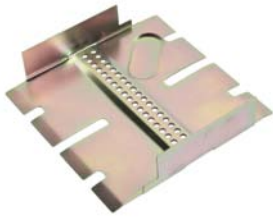

## **SLIP IN WINDAGE TRAY**

This easy to install Windage Tray prevents oil from foaming in the case that robs horsepower. (For total oil control, use with our Stainless Steel Windage Push Rod Tubes P/N: 8531 on page 45).

9147 Slip-In Windage Tray



## **CHROME MAGNETIC DRAIN PLUG**

Helps keep your oil free from metal bits and shavings. Includes sealing washer.

8856 Chrome Magnetic Drain Plug  
(Bulk P/N: 113 115 193)



## **BILLET OIL SUMP PLATE KIT**

This Billet Aluminum Oil Sump Plate will never bend or distort due to over-tightening, thus causing dangerous leaks like stock plates, and it also adds a custom look to any engine. CNC machined from high-grade aluminum billet. Includes chrome magnetic drain plug, special cap nuts and a gasket kit for trouble free installation.

16-8964 Billet Aluminum Oil Sump Plate Kit



## **CHROME SUMP PLATE**

High Quality Chrome Oil Sump Plate. Available with or without drain plug.

8964 Chrome Sump Plate w/Chrome Drain Plug  
8911 Chrome Sump Plate Only  
8911-B Bulk Chrome Sump Plate  
(Ref. P/N: 113 115 181ACR)



## **OIL SCREEN KIT**

Extend the life of your engine by replacing this screen with each and every oil change. Complete with gaskets and sealing washers. (Order Bulk P/N for Oil Screen Only).  
**\*Measurement is at the base of the collar where it joins the oil pick-up tube.**

9923 Oil Screen Kit, 1200cc (40HP), 61-65  
(Bulk P/N: 113 115 175) [Screen Only](#)  
9924 Oil Screen Kit, 1600cc, 70-79 Dual Relief Case  
(Bulk P/N: 111 115 175B) [Screen Only](#)  
98-1160 Oil Screen Kit, 1300-1600cc, 62-69 Single Relief Case  
(Bulk P/N: 311 115 175A) [Screen Only](#)



## **OIL CHANGE GASKET KIT**

Two (2) complete Oil Change Kits. Includes gaskets and sealing washers.

9909 Oil Change Gasket Kit, 2 Kits  
(Bulk P/N: 113 198 031, Each)

## **CHROME OIL CAP**

Stock Style oil cap in high quality chrome.

8968 Chrome Stock Style Oil Filler Cap  
(Bulk P/N: 111 115 485)





# OIL SYSTEM COMPONENTS

## MINI OIL SUMP KIT

Help prevent harmful oil starvation by installing this "mini" sump to increase oil capacity. Kit comes with 3 different size pick-up tubes, studs, nuts, washers, and gaskets. Your existing drain plug can be re-used or use our P/N 8856 magnetic drain plug.

16-9520 Mini Oil Sump Kit

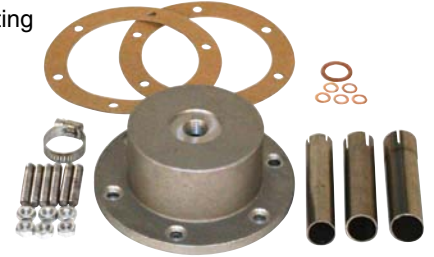

## OIL SUCTION KIT

This kit provides for constant, and consistent oil pick-up. The supplied sump plate depression keeps the pick-up extension submerged in oil at all times. The built in screen helps to keep harmful particles from reaching vital engine components. This is a great addition to any performance built engine or a little extra help to insure a long engine life.

16-9521 Oil Suction Kit

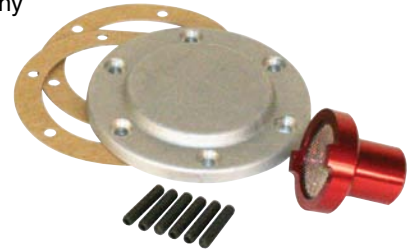

## MINI SUMP W/FILTER

Cast aluminum Mini Sump replaces your stock oil screen and cover and offers improved filtration, helps prevent oil starvation during hard cornering. Easy bolt-on installation. Filter design allows for unimpeded oil flow – even if the filter gets plugged. Filter can be cleaned and reused.

17-2872 Mini Sump w/Filter Kit, Each  
17-2874 Replacement Filter for P/N 17-2871/17-2872, Each



## FULL FLOW REMOTE FILTER KIT

Everything you need to install a full flow remote oil filter system. Our bolt-on kit requires no machining or engine removal. Includes pump cover, remote filter bracket, oil return adapter, fittings, hose and hardware. Oil pump must be threaded and plugged to complete full flow system.

9252 Full Flow Remote Filter Kit - Bolt-On, Each



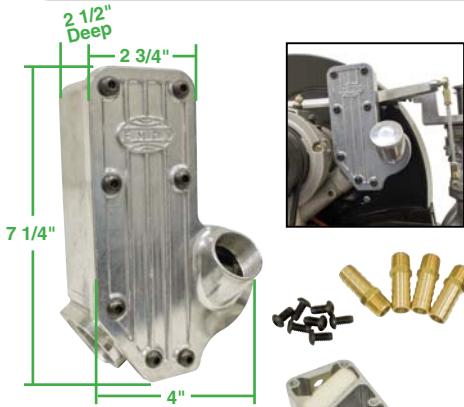

## EMPI OIL FILLER & BREATHER BOX

The EMPI dual-purpose Oil Filler & Breather Box includes a system of internal baffles that separate the oil from the air then returns the oil back to the engine. It mounts upright on the alternator stand making for easy oil filling and was designed to look like part of the engine. The Billet Aluminum filler cap seals with an O'ring. Aluminum construction offers great looks and leak-free operation featuring an O'ring seal and Button-head Allen top screws. Vent your valve covers, crankcase, air cleaners...whatever your requirements. Comes with attaching nut, O'rings, gasket and instructions. There are 4 threaded ports and all are 1/4" NPT.

**17-2941** Oil Filler & Breather Box Kit



## BILLET OIL FILLER CAP

Polished Billet Aluminum Cap with knurled edge for easy grip offers a great finishing touch to any breather tube. Available with or without vent. Fits P/N 17-2941 and alternator stands.

**17-2942** Billet Oil Filler Cap - Vented w/ 3/8" NPT Fitting  
**17-2943** Billet Oil Filler Cap



## BILLET OIL FILL TOWER W/CAP

Use this clean, billet oil fill tower when the alternator has been re-located or not in use. Replaces the alternator stand using existing studs and nuts. Black Anodized Aluminum Cap is included.

**16-9525** Billet Oil Fill Tower w/ Cap



## SMOOTH-FLOW OIL FILLER W/GROOVED CAP

This is the same smooth-flow oil filler as noted above but with our billet grooved cap P/N: 8899. Both cap and body are fully polished just like on P/N: 7904. Now available in Powder-Coated Red, Blue or Black finish. Supplied with 1/4" NPT - 1/2" barbed hose fitting so breather line hookup is easy.

**7902** Billet Oil Filler w/Grooved Cap & w/Vent  
**17-2961** Smooth-Flow Oil Filler w/Grooved Cap & Vent - Red, Each  
**17-2962** Smooth-Flow Oil Filler w/Grooved Cap & Vent - Blue, Each  
**17-2963** Smooth-Flow Oil Filler w/Grooved Cap & Vent - Black, Each





# OIL SYSTEM COMPONENTS

## **SMOOTH-FLOW OIL FILLER W/SMOOTH CAP**

A new design for an old item. This oil filler has a nice smooth look along with a low profile smooth cap design. Knurled cross-groove design on cap allows for good grip even when it's wet or oily. The filler body and cap are made from 6061 T-6 and fully polished to a show car shine! Supplied with 1/4" NPT - 1/2" barbed hose fitting so breather line hookup is easy.

**7904** Billet Oil Filler w/Smooth Cap & w/Vent



## **VERTICAL OIL FILLER W/GROOVED CAP**

Tired of oil spilling all over when you try to add it to your motor? This new design makes it much easier to pour the oil into your motor. Made from fully polished 6061 T-6 billet aluminum it's just the thing to finish off a good looking engine compartment. Supplied with 1/4" NPT - 1/2" barbed hose fitting so breather line hookup is easy.

**7912** Billet Oil Filler, Vertical Filler, w/Groove Cap & w/Vent



## **VERTICAL OIL FILLER W/SMOOTH CAP**

Tired of oil spilling all over when you try to add it to your motor? This new design makes it much easier to pour the oil into your motor. Made from fully polished 6061 T-6 billet aluminum it's just the thing to finish off a good looking engine compartment. Supplied with 1/4" NPT - 1/2" barbed hose fitting so breather line hookup is easy.

**7914** Billet Oil Filler, Vertical Filler, w/Smooth Cap & w/Vent



## **ALUMINUM KNOCK-OFF OIL CAP WITH VENT**

Highly Polished Aluminum Knock-Off style oil cap is easy to use and looks great on your engine. Features a threaded port on top for vent fitting which is supplied. Includes O'ring and 3/8" NPT fitting.

**7903** Billet Aluminum Knock-Off Oil Cap w/Vent, Set



## **BILLET OIL CAPS**

The caps only for the fillers above can also be purchased separately. Choose from either the smooth flow look with knurled edge, easy grip grooved style, or the latest version with etched "OIL" top. All three caps fit all EMPI threaded filler tubes as well as most other threaded aluminum oil fillers.

**8899** Billet Aluminum Oil Filler Cap w/Grooves  
**7905** Billet Smooth Oil Filler Cap  
**16-9512** Billet "OIL" Filler Cap





## **VENTED OIL FILLER TUBE W/SCREW-ON CAP**

Replaces stock type oil filler assembly with polished aluminum filler with high impact plastic cap. Supplied with 1/4" NPT - 1/2" barbed hose fitting so breather line hookup is easy.

- 8904** Vented Oil Filler Tube - Polished w/Plastic Cap
- 8904-7** Replacement Black Plastic Screw-On Cap
- 8901-5** Replacement Vent Fitting



## **BILLET ALUMINUM VENTED BREATHER BOX**

EMPI's Billet polished canister type breather box features high quality all aluminum construction with removable lid for easy servicing of the foam element, provisions for up to four breather lines and a split type mounting clamp that makes installation as easy as tightening two screws. Washable foam insert separates oil from vapors while keeping out dust and dirt. Vapors are released from vents under the cap. Supplied with 1/4" NPT - 1/2" barbed hose fitting so breather line hookup is easy. See page 423 for mounting clamps in additional sizes.

- 16-7030** Polished Aluminum Vented Breather Box, 1 1/2" Tube Mount



## **OFF-ROAD BREATHER**

Designed for maximum breathing filtration. The chrome steel tower design returns the blow-by oil to the engine while the high capacity gauze filter with spun aluminum top cover keeps dirt out during deceleration.

- 8540** Off-Road Breather Kit
- 8541** Replacement Gauze Filter, Each



## **CHROME OIL FILLER & CAP**

Replace stock oil filler and cap with these chrome parts.

- 8965** Chrome Oil Filler w/Tube & Cap, Set
- 8966** Chrome Oil Filler w/Tube
- 8968** Chrome Stock Style Oil Filler Cap
- 8963** Chrome Oil Filler w/o Tube
- 98-1175-B** Seal, Oil Filler Tube, Type 1 50-74, Ghia 56-74, Type 2 50-71, Ea (Ref. P/N: 111 115 491)



# OIL SYSTEM COMPONENTS

## EMPI BILLET BREATHER

Function and form. Finish off your sand rail with these Polished Billet Breather Tubes. Available with colored EMPI covers or with chrome shielded covers. Fittings are for 1/2" I.D. Hose.

- 16-2049 Billet Breather Tube w/Blue Filter Covers
- 16-2050 Billet Breather Tube w/Red Filter Covers
- 16-5153 Billet Breather Tube w/Shielded Filter Covers

- 16-5151 Replacement Filter w/Shielded Cover for P/N: 16-5153, (1" Centered Hole), Each
- 16-5152 Replacement Filter for P/N: 16-2049 & 16-2050 (1" Centered Hole), Each



## OIL FILLER BREATHER

Gauze element breather with Chrome Top fits breather tube vent or other universal applications. 1/2" I.D. with offset hole location. Hole location is very close to the edge.

- 9053 Gauze Oil Filler Breather



## OIL BREATHER FILTER

- 9052 Gauze Breather Filter, Shielded (1/2" centered hole)



9052

## CAST ALUMINUM OIL BREATHER KIT

Reduce crankcase pressure, eliminate blow-by and oil loss. High revving modified engines require more crankcase ventilation than the stock breather can supply. With the EMPI Aluminum Oil Breather Kit the blow-by oil is collected in the foam filter and the air vapors are vented to the atmosphere. New features include the EMPI logo cast in the top, improved heavy duty breather hose, plus internal changes that includes a screen mesh shelf to elevate the foam filter element.

- 8544 Complete Engine Oil Breather Kit
- 9242 Replacement Hose, 1/2" I.D., Black (8 Feet)



8544

## VALVE COVER VENTS

Decrease crankcase pressure, eliminate blow-by and reduce oil loss with these easy to install Valve Cover Vents. Features our Sure O-Ring seal system. Vent into air cleaner or a breather box. Fittings are for 1/2" I.D. Hose.

- 9164 Valve Cover Vents, Pair



## 36HP STYLE FAN SHROUDS

Chrome or Black, these 36HP Style Shrouds feature excellent, tight fit and finish along with correctly engineered internal baffles.

- Doghouse models feature 9 internal Air Directional Baffles/Veins and use late model 'Doghouse' cooler, larger late model fan and special tin.
- Standard models feature 7 internal Air Directional Baffles/Veins



<b>8882</b>	36HP Shroud, Chrome w/o Ducts
<b>8670</b>	36HP Shroud, Black w/o Ducts
<b>8892</b>	36HP Shroud, Chrome w/Ducts
<b>8671</b>	36HP Shroud, Black w/Ducts (7-Vein Design)

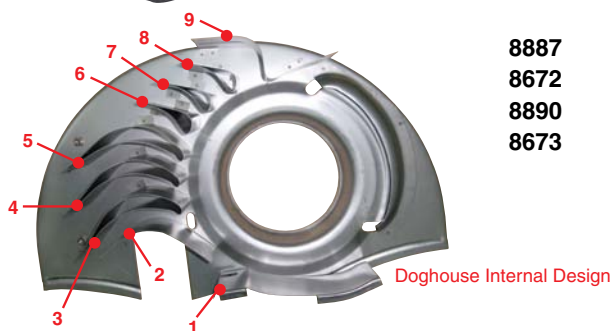

<b>8887</b>	36HP Doghouse Shroud, Chrome w/o Ducts (Boxed)
<b>8672</b>	36HP Doghouse Shroud, Black w/o Ducts (Boxed)
<b>8890</b>	36HP Doghouse Shroud, Chrome w/Ducts (Boxed)
<b>8673</b>	36HP Doghouse Shroud, Black w/Ducts (Boxed) (9-Vein Design)



## RAM-AIR STEEL FAN SHROUDS

Brilliant chrome, without air ducts. This unbaffled fan shroud features a cut-out for an Oil Cooler By-Pass Adapter and a rear fan lip to mount an Air Intake Screen. For use with external oil cooler.

<b>8857</b>	Ram-Air Shroud, Chrome w/o Ducts
-------------	----------------------------------

## CHROME AIR INTAKE SCREEN

Prevents debris from being ingested into the fan. A must for all off-road applications or when engine compartment is subject to external debris. Does not affect intake air volume. The screen is made of heavy duty metal and chrome plated. Fits all up-right fan shrouds with rear fan lip including P/N: 8857 Ram-Air Fan Shrouds.



<b>9195</b>	Air Intake Screen, Chrome
-------------	---------------------------

## FAN SHROUD PLUGS

Zinc plated caps plug the fresh air outlet tubes on your fan shroud, when not in use, to prevent the loss of cooling air to the cylinders. Available in two sizes for the proper fit in both O.E. and EMPI fan shrouds. Complete with mounting screws.



<b>9151</b>	48mm Fan Shroud Plugs for O.E. Shrouds
<b>9161</b>	45mm Fan Shroud Plugs for EMPI Shrouds



# ENGINE ACCESSORIES

## COOLING FANS

The cooling fan is one of the most important and overlooked components in the air cooled engine. Bent or cracked fins, worn hub or out of round fans can cause severe damage to your engine. The late style factory fan is wider than the early version and is compatible with any EMPI fan housing and stock Type 1 & 2 Doghouse fan shrouds and Ram-Air Fan Shrouds. P/N: 98-2004 fits all EMPI 36HP style fan shrouds along with 71 & later stock Doghouse fan shrouds. Our P/N 98-2006 fans are welded with 56 welds, 28 each side, alternating pattern, then statically balanced for higher RPM engines.

- 98-2006** Race Fan (Welded), w/o Hardware  
34.7mm Inner Fan Width / 36.9mm Outer Fan Width  
(Bulk P/N: 98-2006-B)
- 98-2004** Late Fan, 71-on, w/o Hardware  
34.7mm Inner Fan Width / 36.9mm Outer Fan Width  
(Bulk P/N: 7X0 119 031)
- 8898** Fan Hardware Kit (Zinc Plated)  
(Ref. P/N: 111 198 123A)

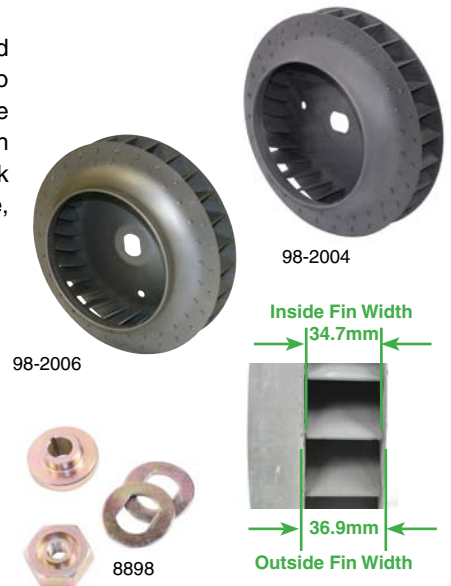

## ALTERNATOR / GENERATOR STAND

Available in Chrome and Stock Style. Complete the look with our accessory oil filler tubes.

- 8991** Alt/Gen Stand, Chrome
- 9194** Alt/Gen Stand, Raw Aluminum  
(Bulk P/N: 113 101 211G)
- 98-0141-B** Gasket, Generator Stand  
Type 1 60-79, Ghia 60-74, Type 2 61-71, Type 3 64-73, Each  
(Ref. P/N: 113 101 219)
- 98-0142-B** Deflector Plate, Gasket Generator Support,  
Type 1 60-79, Ghia 60-74, Type 2 63-71, Type 3 64-73, Each  
(Ref. P/N: 113 101 221B)



## ALTERNATOR / GENERATOR BACKING PLATE KITS

Made from heavy steel our 3-piece stock style kits are available in chrome or black finish.

- 9056** Chrome Steel Stock Style 3-Piece Kit
- 9057** Black Steel Stock-Style 3-Piece Tin Kit
- 9071** Steel Backing Plate Only, Chrome
- 8979** Steel Backing Plate Only, Black



## FINNED BACKING PLATE COVERS

See-Thru Plastic Finned Covers in assorted colors fit over steel backing plate. Use over our P/N: 9071 Chrome Backing Plate for brighter colors.

- 8848** Finned Backing Plate, Red
- 8849** Finned Backing Plate, Blue
- 8850** Finned Backing Plate, Gold
- 8869** Finned Backing Plate, Clear
- 8636** Finned Backing Plate, Neon Pink
- 8637** Finned Backing Plate, Neon Yellow

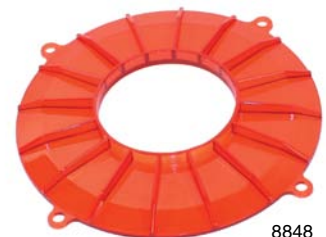

## **CYLINDER COOL TIN**

A must for any performance application. Available in Chrome or Black. Fits most big bore kits. These tins are for 8mm studs.

- 8933** Cool Tin, Chrome, Pair  
**8877** Cool Tin, Black, Pair  
 (Bulk P/N: 113 119 451D)



8877



8933



98-9984-B

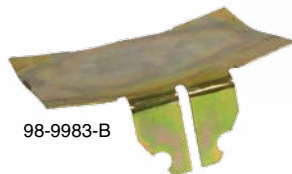

98-9983-B

## **LOWER CYLINDER DEFLECTOR TIN**

Cylinder deflector tin for Volkswagens is an important component when it comes to keeping your engine cool. Taking the air from the fan shroud, it directs it around the cylinders. Must be installed before the pushrod tubes.

- 98-9983-B** Cylinder Deflector Tin, For 10mm Studs,  
 Cad Plated 1500-1600cc  
 (Ref. P/N: 311 119 317A)  
**98-9984-B** Cylinder Deflector Tin, For 8mm Studs,  
 Cad Plated 1500-1600cc  
 (Ref. P/N: 043 119 317A)



9063

## **CYLINDER SHROUDS**

Stamped steel Cylinder Shrouds are finished in Chrome or Gloss Black. Bulk Shrouds are 5 pairs per pack, priced per pair. EMPI cylinder shrouds are formed like O.E. to fit without the gaps at the ends of the fan shroud associated with other aftermarket cylinder shrouds. Now also available for dual port cylinder shrouds in an "off-road" version already trimmed down for sand car or baja use.

### **DUAL PORT CYLINDER SHROUDS**

- 9063** Dual Port Shrouds, Chrome, Pair  
**9063-9** Bulk Dual Port Shrouds, Chrome  
*(Must buy multiples of 5 pairs)*  
**8990** Dual Port Shrouds, Black, Pair  
**8990-9** Bulk Dual Port Shrouds, Black  
*(Must buy multiples of 5 pairs)*  
 (Ref. P/N: 113 119 303J/4H)



8990



16-9501

### **OFF-ROAD DUAL PORT CYLINDER SHROUDS**

- 16-9502** Off-Road Dual Port Shrouds, Chrome, Pair  
**16-9502-9** Bulk Off-Road Dual Port Shrouds, Chrome  
*(Must buy multiples of 5 pairs)*  
**16-9501** Off-Road Dual Port Shrouds, Black, Pair  
**16-9501-9** Bulk Off-Road Dual Port Shrouds, Black  
*(Must buy multiples of 5 pairs)*



16-9502



8878

### **SINGLE PORT CYLINDER SHROUDS**

- 8878** Single Port Shrouds, Chrome, Pair  
**8878-9** Bulk Single Port Shrouds, Chrome  
*(Must buy multiples of 5 pairs)*  
**8867** Single Port Shrouds, Black, Pair  
**8867-9** Bulk Single Port Shrouds, Black  
*(Must buy multiples of 5 pairs)*  
 (Ref. P/N: 113 119 303B/4G)



8867





# ENGINE ACCESSORIES

## **DOGHOUSE ENGINE TIN**

2 piece tin set attaches to the back of a doghouse type shroud to direct the hot air coming off the cooler out of the engine compartment. Complete with seals.

- 8896** Doghouse Tin, Chrome, 2 pcs.
- 8884** Doghouse Tin, Black, 2 pcs.



## **ENGINE TIN**

Correct fitting engine tin is necessary to maintain proper engine operating temperatures. Available in chrome or black.

### **FRONT ENGINE TIN**

Fits between engine and transmission. Available in chrome or black. (All Front Engine Tin Sold in Bulk Only).

- 8930** Front Tin, Chrome, Late Doghouse Style
- 8952** Front Tin, Black, Late Doghouse Style  
(Ref. P/N: 113 119 517S)

- 8945** Front Tin, Chrome, Early
- 8951** Front Tin, Black, Early  
(Ref. P/N: 113 119 517R)



### **REAR ENGINE TIN**

Seals off exhaust heat from engine compartment. Available in chrome or black with or without Fresh Air Hose and/or Heat Riser holes. (All Rear Engine Tin Sold in Bulk Only).

- 8938** Rear Tin, Stock Style, Black  
(Ref. P/N: 043 119 527)
- 8940** Rear Tin, Stock Style, Chrome
- 8936** Rear Tin, w/Hose, w/o Heat Riser, Black
- 8941** Rear Tin, w/Hose, w/o Heat Riser, Chrome
- 8937** Rear Tin, w/o Hose, w/Heat Riser, Black
- 8943** Rear Tin, w/o Hose, w/Heat Riser, Chrome
- 8939** Rear Tin, w/o Hose, w/o Heat Riser, Black
- 8942** Rear Tin, w/o Hose, w/o Heat Riser, Chrome



### **ENGINE PULLEY TIN**

Available in chrome or black.

- 8935** Engine Pulley Tin, Black  
(Bulk P/N: 113 119 533L)
- 8960** Engine Pulley Tin, Chrome





8949

## HEATER CHANNEL KIT - 3 PIECE

The finishing touch to control engine heat. Fits between heater boxes and engine case. Available in chrome or black.

- 8948 Heater Channel Kit, 3 pcs., Black
- 8949 Heater Channel Kit, 3 pcs., Chrome



## HEATER CHANNEL MOUNT KIT

Set of four new Steel Mounting Tabs. Perfect for replacing stock tabs broken off heater boxes or custom fabricating your own when heater boxes have been eliminated and J-tubes are being used (Raw).

- 3359 Heater Channel Mount (4 pcs.)



## SHROUD SPACER KIT

These spacers fill in the gap between the cylinder tins and the bottom of the fan shroud that results from many high performance VW engine builds.

- 16-9511 Aluminum Shroud Spacer Kit, Pair



## STAINLESS STEEL 6MM BUTTON HEAD ALLEN SHROUD SCREW KIT

Cool looking Stainless Steel Button Head Allen Shroud Screws with Stainless Steel Washers to finish off your shroud and tins. Includes 34 Screws, 34 Washers and an Allen Wrench.

- 17-2960 6mm Stainless Steel Button Head Allen Shroud Screw Kit, 34pcs



## SHROUD SCREW KIT

New Shroud Screws with attached washers.

- 9524 Shroud Screw Kit, 12 Pcs.
- 9524-B Bulk Shroud Screws, Bag of 100  
(Ref. P/N: N 10 710 8)



8743

## ENGINE TRIM KIT - COLORS

This Kit includes Distributor Cap, Copper Core Spark Plug Wire Set, Finned Pulley Cover and Finned Backing Plate Cover.

- 8743 Engine Trim Kit, Blue
- 8744 Engine Trim Kit, Red
- 8745 Engine Trim Kit, Yellow/Gold
- 8746 Engine Trim Kit, Black/Clear



## ***SUPER CHROME & COLOR-DELUXE ENGINE KIT***

Kits feature All Chrome accessories and colorful accent pieces. Includes Finned Backing Plate, Finned Pulley Cover, Wire Separators, Distributor Cap, Ignition Wires, Magnetic Drain Plug, Alt/Gen Strap, Chrome Stock Style Valve Covers with Bales, Distributor Clamp, Sump Plate, Oil Filler w/Tube, Stock Style Oil Cap, Stock Length Dipstick, Coil cover, Backing Plate, Pulley Bolt & Washer, 2-Piece Generator Nut and 12-Volt Alt/Gen Pulley.

- 8653 Super Color Deluxe Engine Kit, Red
- 8654 Super Color Deluxe Engine Kit, Blue
- 8655 Super Color Deluxe Engine Kit, Yellow/Gold
- 8656 Super Color Deluxe Engine Kit, Black/Clear



---

## ***SUPER CHROME DELUXE DRESS-UP KIT***

This Kit includes Magnetic Drain Plug, Alt/Gen Strap, Chrome Stock Style Valve Covers with Bales, Distributor Clamp, Sump Plate, Oil Filler with Tube, Stock Oil Cap, Stock Length Dipstick, Coil Cover, Backing Plate, Pulley Bolt & Washer, 2-Piece Alt/Gen Nut and 12-Volt Alt/Gen Pulley.

- 8742 Super Chrome Deluxe Dress-Up Kit



---

## ***DELUXE CHROME DRESS-UP KIT***

This Kit includes Distributor Clamp, Oil Filler with Tube, Stock Style Oil Cap, Stock Length Dipstick, Pulley Bolt & Washer, 2-Piece Alt/Gen Nut and 12-Volt Alt/Gen Pulley.

- 8741 Deluxe Chrome Dress-Up Kit



---

## ***CHROME DRESS-UP KIT***

This Kit includes Distributor Clamp, Stock Style Oil Cap, Stock Length Dipstick, Pulley Bolt & Washer and 2-Piece Alt/Gen Nut.

- 8740 Chrome Dress-Up Kit



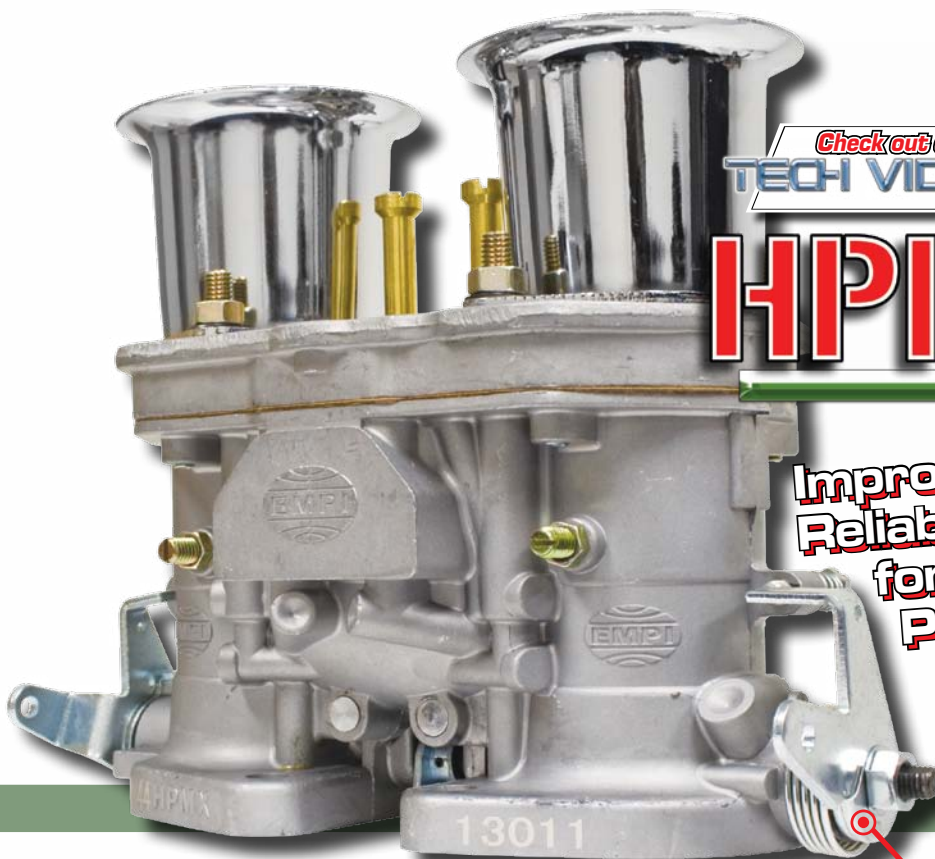

Check out our  
**TECH VIDEOS**

# HPMX 3.0

**Improved Performance,  
Reliability, and Drivability  
for 40/44 HPMX  
Performance  
Carburetors**



**Choke Circuit  
Eliminated -  
No Accidental  
Enrichment!**



**New Reusable  
Body Gasket**



**New Improved  
Linkage Arms**



**New Accelerator  
Pump Spring  
and Diaphragm  
for Smoother  
Acceleration**

**Lightweight Poly Ball  
in Exhaust Pump Valve**

## EMPI HPMX CARBURETOR

Performance, reliability and race proven. EMPI HPMX Carbs. offer ultimate engine tuning with total air and fuel metering and adjustment. The EMPI HPMX series have separate idle and main circuits featuring changeable air and fuel jets. Intake air is metered by changeable venturies, and the accelerator pump is adjustable for maximum acceleration. Jets, gaskets and repair parts are readily available. All our kits are pre-jetted for most VW engines. Choose the appropriate size carburetor for your application. When future engine modification is planned, size-up now! Basic rule of thumb...

- 40mm Carbs. for engines up to 2000cc
- 44mm Carbs. for engines 2100cc and up

### EMPI HPMX CARBURETOR ONLY

47-1010	40HPMX Carb Only, w/ Chrome Velocity Stacks for Dual Carb Set-Ups
47-1010-2	40HPMX Carb Only, w/ Chrome Velocity Stacks for Single Carb Set-Ups
47-1012	44HPMX Carb Only, w/ Chrome Velocity Stacks for Dual Carb Set-Ups
47-1012-2	44HPMX Carb Only, w/ Chrome Velocity Stacks for Single Carb Set-Ups

**These EMPI HPMX  
carburetors & kits  
include chrome  
velocity stacks!**



40/44 HPMX

**\* Float Levels Checked  
\* Test Run  
\* Jetted and Adjusted**



# INTAKE - CARB. KITS & COMPONENTS



**47-1010**  
**47-1012**

**Test Run and Adjusted for smooth performance**

*Check out our*  
**TECH VIDEOS**

## [ EMPI 40/44 HPMX FOR DUALS ]



All EMPI 40/44 HPMX Carbs are test run.

Float levels checked and set.

Carbs jetted for smooth operation.

All EMPI 40/44 HPMX Carbs come with chrome velocity stacks.

**Dual 40 HPMX** Carbs come with .52 Idle Jets, .115 Main Jets, .200 Air Jets, 28mm Venturi, .550 Ex. Pump Jets, and .50 Accelerator Pump Jets.

**Dual 44 HPMX** Carbs come with .55 Idle Jets, .135 Main Jets, .200 Air Jets, 36mm Venturi, .550 Ex. Pump Jets and .50 Accelerator Pump Jets.

Both use F11 Emulsion Tubes.

Both use 2.00mm Needle Valve.



## [ EMPI 40/44 HPMX FOR SINGLES ]



**47-1010-2**  
**47-1012-2**

**Test Run and Adjusted for smooth performance**

*Check out our*  
**TECH VIDEOS**

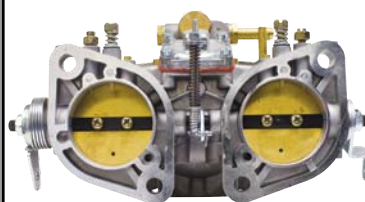

All EMPI 40/44 HPMX Carbs are test run.

Float levels checked and set.

Carbs jetted for smooth operation.

All EMPI 40/44 HPMX Carbs come with chrome velocity stacks.

Single Carb applications have an idle hole drilled in the butterfly for both the 40 and 44 HPMX Carbs.

**Single 40 HPMX** Carbs come with .60 Idle Jets, .135 Main Jets, .160 Air Jets, 28mm Venturi, .350 Ex. Pump Jets, and .50 Accelerator Pump Jets.

**Single 44 HPMX** Carbs come with .60 Idle Jets, .140 Main Jets, .160 Air Jets, 30mm Venturi, .350 Ex. Pump Jets, and .55 Accelerator Pump Jets.

Both use F11 Emulsion Tubes.

Both use 2.00mm Needle Valve.



# INTAKE - CARB. KITS & COMPONENTS



## EMPI Ultra Dual HPMX Carburetor Kits

New EMPI Ultra Dual HPMX Carb Kits with new Combo Linkage & Air Cleaners and Off-Set Manifolds... Available with 40 & 44HPMX Carburetors. Complete kit with HPMX Carbs, Off-Set Manifolds, Linkage, Hi-Flow Gauze Air Filter Elements, Coil Relocation Bracket, Hardware, Gaskets, Detailed Illustrated Instructions and more.

Check out our  
**TECH VIDEOS**

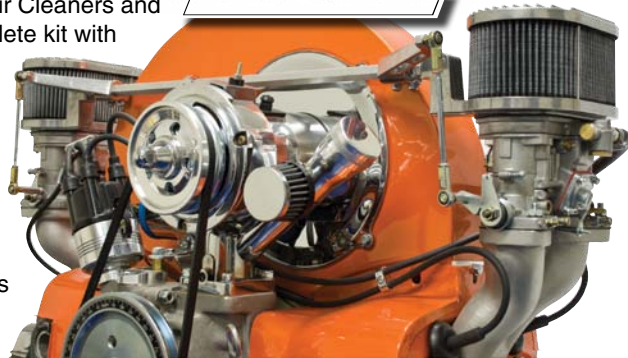

May not fit with stock fan shroud without modification.



### Off-Set Manifolds...

- Positions the carburetors straight across the engine
- Thick side walls for custom porting and port matching
- Helps eliminate body clearance issues



### Hex Bar/Air Cleaner Linkage Combo Design

- Great looks – Cast A/C Bottoms & Tops with built-in X-Bar Support
- Precise throttle control
- For Off-Set Manifolds ONLY



Aluminum Air Cleaner Tops

47-7335  
47-7336

Ultra Dual 40HPMX Kit Complete, Type 1  
Ultra Dual 44HPMX Kit Complete, Type 1



47-7335



Aluminum Air Cleaner Base and Linkage Mount. All One Piece

## EMPI Ultra Dual HPMX Hex Bar/Air Cleaner Linkage Combo Kit

Complete kit with Off-Set Manifolds, Linkage, Hi-Flow Gauze Air Filter Elements, Coil Relocation Bracket, Hardware, Gaskets, Detailed Illustrated Instructions and more....Just add Carburetors!

47-7332  
47-7334

Ultra Hex Bar/Air Cleaner Linkage Combo Kit w/ Manifolds, Type 1  
Deep Off-Set Manifold Kit, with Necessary Gaskets and Hardware

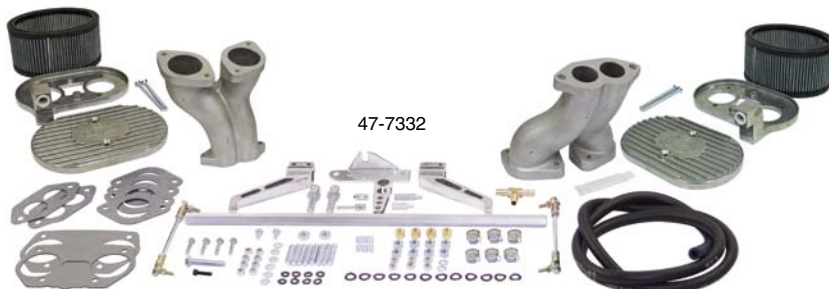

47-7332



47-7334

Extra Thick Aluminum Manifolds



# INTAKE - CARB. KITS & COMPONENTS

Heavy Gauge Steel!



Aluminum Hex Rod!



Diecast Aluminum!

Check out our TECH VIDEOS

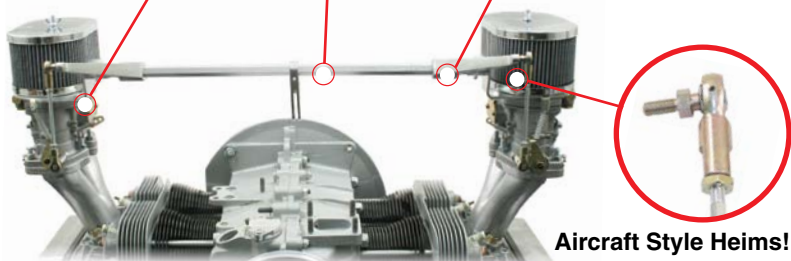

Aircraft Style Heims!

## EMPI DUAL HPMX HEXBAR CARBURETOR KITS TYPE 1

The EMPI Hex Bar HPMX Carburetor Kits have many of the features of our Deluxe EMPI Kits. All Kits feature:

Aluminum Alloy Hex Bar with Steel Ball Ends - **Sealed Aircraft Heim Rod Ends** - Ball Burnished/Polished - **Offset Aluminum Intake Manifolds** - Thick High Strength Steel Linkage Mounts - **Chrome Air Filters with High Flow Gauze Elements** - Coil Relocation Mount - **Brass Fuel Tee** - **Detailed and Illustrated Instructions** - Attractive EMPI Packaging.

All Dual HPMX Carb Kits are run as pairs and set up for right and left sides ([See page 69 for additional specifications](#)).

May not fit with stock fan shroud without modification.

## EMPI DUAL HPMX TYPE 1 CARB. KITS WITH CHROME AIR CLEANERS



47-7319

**1500-1600CC BASED UP-RIGHT ENGINES**

Test Run and Adjusted for smooth performance

- 47-7317 EMPI Dual 40HPMX Kit
- 47-7319 EMPI Dual 44HPMX Kit

These EMPI HPMX carburetors & kits include chrome velocity stacks!



47-1010 40HPMX Carburetor Only, w/ Chrome Velocity Stacks for Duals

47-1012 44HPMX Carburetor Only, w/ Chrome Velocity Stacks for Duals

## EMPI DUAL HPMX TYPE 1 CARB. KITS WITHOUT AIR CLEANERS



47-6317

**1500-1600CC BASED UP-RIGHT ENGINES**

- 47-6317 EMPI Dual 40HPMX Kit
- 47-6319 EMPI Dual 44HPMX Kit

These EMPI HPMX carburetors & kits include chrome velocity stacks!

Test Run and Adjusted for smooth performance

# INTAKE - CARB. KITS & COMPONENTS



## EMPI DUAL DELUXE HPMX CARB KITS - TYPE 1

EMPI's Deluxe HPMX Carburetor Kits are the finest available. We have re-engineered them to offer many outstanding features not found in other kits. Features include:

Aluminum Alloy Hex Bar with Steel Ball Ends - **Sealed Aircraft Heim Joint Rod Ends** - Ball Burnished/Polished Offset Aluminum Intake Manifolds - Thick High Strength Steel Linkage Mounts - **Solid Aluminum Base/Top Air Cleaner Assemblies** - High Flow Gauze Elements - **Coil Relocation Mount** - Brass Fuel Tee - **Fuel Filter** - Brass Manifold Nuts - **Detailed Illustrated Instructions** - Attractive EMPI Packaging.

All Dual HPMX Carb Kits are run as pairs and set up for right and left sides (See page 69 for additional specifications).

Fits with most stock fan shrouds with little or no modification.



### EMPI DELUXE DUAL HPMX TYPE 1 CARB. KITS WITH BILLET ALUMINUM AIR CLEANERS



**Billet 6061 T-6 Aluminum A/C Assemblies**



**Test Run and Adjusted for smooth performance**

**These EMPI HPMX carburetors & kits include chrome velocity stacks!**

#### 1500-1600CC BASED UP-RIGHT ENGINES

47-9317 EMPI Deluxe Dual 40HPMX Kit

47-9319 EMPI Deluxe Dual 44HPMX Kit

*Fits with stock fan housing with no or slight modification.*

**47-1010**  
40HPMX Carburetor Only, w/ Chrome Velocity Stacks for Duals

**47-1012**  
44HPMX Carburetor Only, w/ Chrome Velocity Stacks for Duals



### EMPI DELUXE DUAL HPMX TYPE 1 CARB. KITS WITH CHROME AIR CLEANERS



#### 1500-1600CC BASED UP-RIGHT ENGINES

**47-8317**  
EMPI Deluxe Dual 40HPMX Kit

**47-8319**  
EMPI Deluxe Dual 44HPMX Kit

*Fits with stock fan housing with no or slight modification.*

**Test Run and Adjusted for smooth performance**

**These EMPI HPMX carburetors & kits include chrome velocity stacks!**





# INTAKE - CARB. KITS & COMPONENTS

## EMPI HPMX CARB KITS - TYPE 1, 2, 3 & 4

Performance, reliability and race proven EMPI HPMX Carbs offer ultimate engine tuning with total air and fuel metering and adjustment. The EMPI HPMX series have separate idle and main circuits featuring changeable air and fuel jets. Intake air is metered by changeable venturiers, and the accelerator pump is adjustable for maximum acceleration. Jets, gaskets and repair parts are readily available. All our kits are pre-jetted for VW engines.

**\*Test Run & Adjusted  
\*44 HPMX come with  
.60 Idle Jets, .140 Main Jets,  
.160 Air Corrector Jets,  
.55 Accelerator Pump Jets,  
.350 Ex. Pump Jets,  
30mm Venturis and  
F11 Emulsion Tubes.**



**These EMPI HPMX carburetors & kits include chrome velocity stacks!**

**\*Test Run & Adjusted  
\*40 HPMX come with  
.60 Idle Jets, .135 Main Jets,  
.160 Air Corrector Jets,  
.50 Accelerator Pump Jets,  
.350 Ex. Pump Jets,  
28mm Venturis and  
F11 Emulsion Tubes.**

Check out our **TECH VIDEOS**

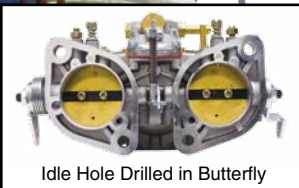

Idle Hole Drilled in Butterfly

### SINGLE EMPI HPMX TYPE 1 CARB. KITS WITH AIR CLEANER

For those that choose ease of maintenance along with performance gains, the single 40/44 HPMX is the set-up of choice. For the basic 1600-1800cc, the 40 HPMX Kit is a torquey option. For all out performance, the way to go is the 44 HPMX. The 44 HPMX carbs in these kits have 30mm venturis and .55 accelerator pump jets installed. EMPI also has available a selection of jets if your application requires further "dialing in" (See pages 109-111). Both 40 HPMX and 44 HPMX Carbs have butterflies drilled for smooth idling. Complete kits feature Aluminum Center-Section Manifold, Aircraft Style Heim Joint Linkage, Chrome Air Cleaner with gauze element, gaskets and hardware. Complete with detailed illustrated instructions and attractive EMPI packaging. Fits Type 1 1600cc based upright engines. (Requires P/N: 3236 dual port end kit or P/N: 3237 single port end kit). See page 69 for additional specifications.

## EMPI SINGLE HPMX TYPE 1 CARB. KITS WITH CHROME AIR CLEANER

**These EMPI HPMX carburetors & kits include chrome velocity stacks!**

### NEW ISOLATED MANIFOLD

**Test Run and Adjusted for smooth performance**



47-7316

### 1500-1600CC BASED UP-RIGHT ENGINES

- 47-7315 EMPI Single 40HPMX Kit
- 47-7316 EMPI Single 44HPMX Kit



- 47-1010-2 40HPMX Carburetor Only, w/ Chrome Velocity Stacks for Singles
- 47-1012-2 44HPMX Carburetor Only, w/ Chrome Velocity Stacks for Singles

# INTAKE - CARB. KITS & COMPONENTS



## DUAL EMPI HPMX CARBURETOR KITS FOR TYPE 2/4

The same rules apply to 1700-2000cc pancake engines as they do to Type 1 engines. Install a set of EMPI HPMX, sit back, hang-on and enjoy the performance gains. All EMPI Type 2/4 kits feature all the same high quality hardware and components as our other standard Dual HPMX kits. Choose the size of carburetor that best fits your application. Comes complete with detailed installation instructions and EMPI packaging. All kits come with hardware for complete installation on Porsche 914's as well.



### EMPI DUAL HPMX CARB. KITS FOR TYPE 2/4 WITH CHROME AIR CLEANERS

Test Run and Adjusted for smooth performance

47-7347



1700-2000CC TYPE 2/4 & 914 ENGINES

- 47-7347  
EMPI Dual 40HPMX Kit
- 47-7295  
EMPI Dual 44HPMX Kit

These EMPI HPMX carburetors & kits include chrome velocity stacks!

### EMPI DUAL HPMX CARB. KITS FOR PORSCHE WITH CHROME AIR CLEANERS

Test Run and Adjusted for smooth performance

48-1291



These EMPI HPMX carburetors & kits include chrome velocity stacks!

PORSCHE 356/912 ENGINES

- 48-1291 EMPI Dual 40HPMX Kit
- 48-1292 EMPI Dual 44HPMX Kit

47-1010  
40HPMX Carburetor Only, w/  
Chrome Velocity Stacks for Duals

47-1012  
44HPMX Carburetor Only, w/  
Chrome Velocity Stacks for Duals

### EMPI DUAL HPMX CARB. KITS FOR TYPE 3 WITH AIR CLEANERS

Test Run and Adjusted for smooth performance

47-7341



47-7341  
EMPI Dual 40HPMX Kit, Type 3

47-7342  
EMPI Dual 44HPMX Kit, Type 3

This kit supplied without velocity stacks

Fits Under Decklid!



# INTAKE - CARB. KITS & COMPONENTS

Horsepower and the True Downdraft Carburetor have been synonymous for years. Now EMPI brings you its all new EPC 48 and EPC 51 Carburetors. The EPC 48's come with 37mm Venturis and the EPC 51's come with massive 48mm Venturis. Also, both come with a third progression hole for improved drivability and enlarged float bowl. Both sizes are equipped with spun aluminum velocity stacks, compatible with air cleaners. *All parts are interchangeable with the Weber 48 IDA.*

**\*NEW**

All EPC 48's and 51's come with a 3rd progression hole and enlarged float bowl.

## [ EMPI EPC 48/51 ]

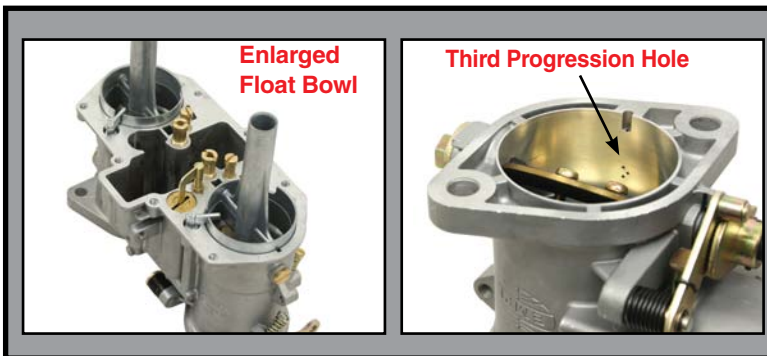

**Test Run**

See page 76-77 for application and kits

**47-1048/47-1050**

### REPLACEMENT PARTS FOR EPC 48/51 CARBS (WILL ALSO FIT WEBER 48 IDA)

See page 109-111 for other components.

- 43-5343 EPC 48/51 3.0 Needle and Seat (To Replace 2.0)
- 43-5344 EPC 48/51 Stack Hold Down Screw and Washer
- 43-5345 EPC 48/51 Stack Hold Down Tab
- 43-5346 EPC 48/51 Fast Idle Screw and Spring
- 43-5347 EPC 48/51 Air Fuel Mixture Screw and Spring
- 43-5348 EPC 48/51 Main Jet Screen
- 43-5349 EPC 48/51 Top Gasket
- 43-5353 EPC 48/51 Auxiliary Venturi
- 43-5355 Banjo Fitting w/ Press In 1/4" Barb
- 43-6973 EPC 48/51 Float Only



### 48/51 EPC/IDA SHORT MANIFOLDS

EMPI 48/51 EPC/IDA Short Manifolds allow extra clearance for use with air cleaners or velocity stacks. All kits include Intake and Carburetor Base Gaskets, Studs, Nuts, Spring Washers and Extended Nuts.

- 47-0631** **NEW!** 48/51 EPC/IDA Short Manifolds, Pair  
Allows 48/51 EPC/IDA carbs in a sedan with no or minimal cutting of your car, engine lid or velocity stacks. May not fit with all stock Doghouse fan shrouds.  
Right and Left use the same Manifold
- 47-0632** **NEW!** 48/51 EPC/IDA Off-Set 'Sleeper' Manifolds, Pair  
Allow Air Cleaners in a Type 1 with the Engine Lid Closed  
Used in Street Sleeper kit





## EMPI DUAL 48/51 EPC STREET SLEEPER DUAL CARB KITS

Another Industry 1st...this EMPI Dual 48/51 EPC Kit features our special short manifolds, 48/51 EPC Carbs featuring 3 Progression Ports and an Enlarged Float Bowl, EMPI Billet Twist Linkage and a pair of Chrome Air Cleaners with Gauze Elements...**All that fits under a Stock Engine Lid without the need for Deck-Lid Stand-offs or a raised engine lid.**

The 'Cool' of running Dual 48s or 51s with excellent power and driveability **with Air Cleaners!** Dyno-Tested by **Head's Up Performance**. The carbs are baseline jetted for small (1600-1800cc) motors – and will require jetting to your specific application. Dual 48s or 51s for the street...doesn't get any better than this!

Complete kit includes Manifolds, Carburetors, Twist Linkage, Chrome Air Cleaners, installation hardware and gaskets.

To assist you in establishing a baseline for custom jetting your carburetor, we have included the following components with each carburetor at no extra charge:

**(2) .150 Main Jets (P/N 43-5309), (2) .190 Air Correction Jets (P/N 43-5419), (2) .65 Idle Jets (P/N 43-5541)**

**EMPI EPC 48's come with 37mm Venturis.**

**EMPI EPC 51's come with 48mm Venturis. Both feature a third Progression hole and enlarged Float Bowl for 11% more capacity.**

**47-0630** Dual 48EPC Street Sleeper Dual Carb Kit

**47-0635** **NEW!** Dual 51EPC Street Sleeper Dual Carb Kit



**47-0630**  
Fits under a Stock Engine Lid



47-0630

## EMPI DUAL 48/51 EPC SHORT MANIFOLD DUAL CARB KITS

Dual 48/51EPC Carburetor Kits featuring Short Manifolds for installation in a Sedan with minimal or no cutting of your car, engine lid or velocity stacks. May not fit with all stock Doghouse fan shrouds. Right and left use the same manifold.

Complete kit includes Manifolds, Carburetors, Twist Linkage, Chrome Air Cleaners, installation hardware and gaskets.



47-0637

**47-0636** **NEW!** Dual 48EPC Short Manifold Dual Carb Kit

**47-0637** **NEW!** Dual 51EPC Short Manifold Dual Carb Kit



# INTAKE - CARB. KITS & COMPONENTS

## EMPI EPC 48/51 CARB KITS

Complete Kits ready for installation. These Carburetors are primarily used on High Performance Engines. Most installers will custom jet them to their exact application.



We supply these Carburetors with the following already installed:

- \_\_\_\_\_ .135 Main Jets
- \_\_\_\_\_ .70 Low Speed Jets
- \_\_\_\_\_ F7 Emulsion Tubes
- \_\_\_\_\_ .120 Air Correction Jets
- \_\_\_\_\_ 2.0 Needle and Seat

To assist you in establishing a baseline for custom jetting your carburetor, we have included the following components with each carburetor at no extra charge:

**(2) .150 Main Jets (P/N 43-5309), (2) .190 Air Correction Jets (P/N 43-5419), (2) .65 Idle Jets (P/N 43-5541)**

**EMPI EPC 48's come with 37mm Venturis.**

**EMPI EPC 51's come with 48mm Venturis. Both feature a third Progression hole and enlarged Float Bowl for 11% more capacity.**

### EPC 48 CARB KITS W/ ROUND CHROME CROSS BAR LINKAGE

**47-7328** EMPI Dual EPC-48, Type 1, w/ Standard Manifolds (Kit supplied with 43-5240 Linkage)

**47-7329** EMPI Dual EPC-48, Type 1, w/ Race Manifolds (Kit supplied with 43-5240 Linkage)

**47-1048** EMPI EPC-48 Carburetor Only w/ Enlarged Float Bowl, 3rd Progression Hole, Aluminum Velocity Stacks, and Jet Kit, Each



### EPC 48 CARB KITS W/ HEX CROSS BAR LINKAGE

**47-7330** EMPI Dual EPC-48, Type 1, w/ Standard Manifolds (Kit supplied with 43-5242 Hex Bar Linkage)

**47-7331** EMPI Dual EPC-48, Type 1, w/ Race Manifolds (Kit supplied with 43-5242 Hex Bar Linkage)

**47-1048** EMPI EPC-48 Carburetor Only w/ Enlarged Float Bowl, 3rd Progression Hole, Aluminum Velocity Stacks, and Jet Kit, Each



### EPC 51 RACE CARB KIT W/ HEX CROSS BAR LINKAGE

**47-7429** EMPI Dual EPC-51, Type 1, w/ Race Manifolds (Kit supplied with 43-5242 Hex Bar Linkage)

**47-1050** EMPI EPC-51 Carburetor Only w/ Enlarged Float Bowl, 3rd Progression Hole, Aluminum Velocity Stacks, and Jet Kit, Each



43-5215

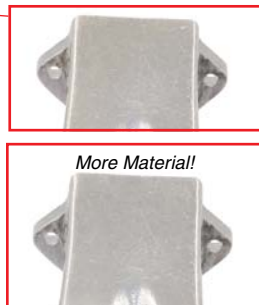

More Material!



43-5214

**43-5214** 48/51EPC/IDA Tall Manifolds – Racing Style with Additional Material for Porting, Pair

**43-5215** 48/51EPC/IDA Tall Manifolds – Standard Style with Material for Porting, Pair

See page 75 for pictures of carbs.  
See page 88 for Linkage and Manifolds separately.

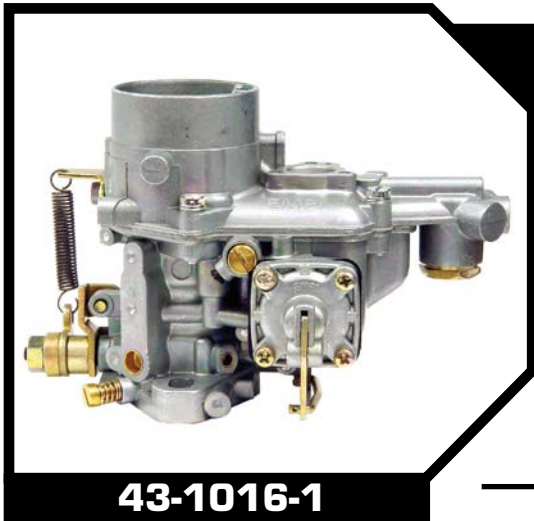

**43-1016-1**

## EMPI EPC 34



EMPI EPC 34 Carbs are supplied with these jets installed:

- 1.75 Needle & Seat
- .150 Main Jet
- .55 Idle Jet
- .175 Air Corrector Jet
- F-6 Emulsion Tubes



47-7421 **NEW!**

### DELUXE DUAL 34 EPC KIT

Complete Deluxe Dual 34EPC Carb Kit featuring Tall Manifolds offering increased horsepower, improved idle and drivability and EMPI Twist-Pull Linkage. Includes a 1/2" X-Over tube that attaches with supplied fittings to the upper plenum section of the manifolds so that the vacuum is taken equally from the cylinders. The kit comes complete with EMPI 34EPC carburetors, manifolds, fittings and quality upgrade for any Type 1 Dual 34EPC/ICT carb system. Includes fuel hose and all necessary hardware and gaskets to complete the installation.

47-7421 **NEW!**

Tall 34EPC/ICT Manifold Kit,  
Type 1 1300-1600 Dual Port



Kit **NEW!**

### DUAL 34 EPC/ICT TALL MANIFOLD KIT

These Tall Manifolds offer increased horsepower, improved idle and drivability for your Dual 34 EPC/ICT carburetors. They feature a 1/2" X-Over tube that attaches with supplied fittings to the upper plenum section of the manifolds so that the vacuum is taken equally from the cylinders. The kit comes complete with manifolds, fittings and quality fuel hose to complete the installation. A perfect upgrade for any Type 1 Dual 34EPC/ICT carb system. Requires the use of Twist-Pull Linkage.



Manifolds

43-5216 **NEW!**

Tall 34EPC/ICT Manifold Kit,  
Type 1 1300-1600 Dual Port



# INTAKE - CARB. KITS & COMPONENTS

## EMPI VW DUAL EPC 34 CARB KITS FOR TYPE 1, 2, 3 & 4

If improving performance without sacrificing fuel economy is your desire, then the EMPI EPC 34 Dual Kits are the way to go. All Kits feature:

- Aluminum Alloy Hex Bar with Steel Ball Ends - Sealed Aircraft Heim Rod Ends - High Flow Aluminum Intake Manifolds - Thick High Strength Steel Linkage Mounts - Gauze High Flow Air Cleaner Assemblies - Coil Relocation Mount - Brass Fuel Tee - Detailed and Illustrated Instructions - Attractive EMPI Packaging (See page 78 for additional specifications).

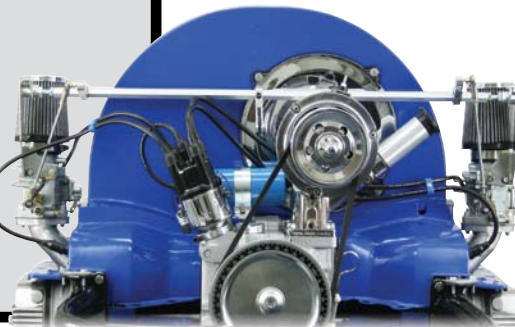

### EMPI DUAL EPC 34 FOR TYPE 1

We supply these Carburetors with the following already installed:

- 1.75 Needle and Seat
- .150 Main Jet
- .55 Idle Jet
- .175 Air Correction Jet
- F-6 Emulsion Tubes

### 1500-1600cc Up-Right Based Engines

- 47-7401 EMPI Dual EPC 34 Kit, Type 1 Single Port w/Air Cleaners
- 47-7411 EMPI Dual EPC 34 Kit, Type 1 Dual Port w/Air Cleaners
- 43-1016-1 EMPI EPC 34 Carb. Only, Each



47-7401

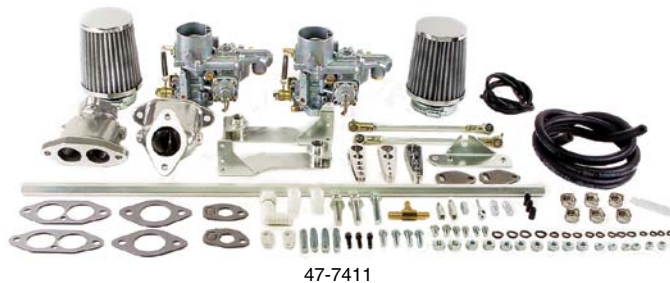

47-7411

### EMPI DUAL EPC 34 FOR TYPE 3 ENGINES

- 47-7301 EMPI Dual EPC 34 Kit, Type 3 Single Port w/Air Cleaners
- 47-7311 EMPI Dual EPC 34 Kit, Type 3 Dual Port w/Air Cleaners
- 43-1016-1 EMPI 34 Carb. Only, Each



47-7301

### EMPI DUAL EPC 34 FOR TYPE 2/4, 914 ENGINES

Distance from Base of Intake Manifold to Top of Air Cleaner is 9 inches. Supplied with spare jets.

- 47-7412 EMPI Dual EPC 34 Kit, 1700-2000cc Type 2/4 & 914 Engines w/Air Cleaners
- 43-1016-1 EMPI EPC 34 Carb. Only, Each



47-7412



## EMPI 38EGAS SINGLE CARBURETOR KIT

A synchronous 38mm, 2-Barrel carburetor perched on an isolated center-section aluminum manifold featuring a true Pre-Heat System and an Electric Choke. This is a perfect intake system for street or off-road offering excellent power, performance and drivability. The kit includes an EMPI 38EPC Carburetor, Intake Manifold with pre-heater tubes, Chrome Air Cleaner with gauze element, linkage, gaskets, hardware and instructions.

Base line jetted for 1600cc.  
**Must use Electric Fuel Pump.**

### Factory Jetting:

45 Idle
145 Main
170 Air
F50 E Tube
65 Pump

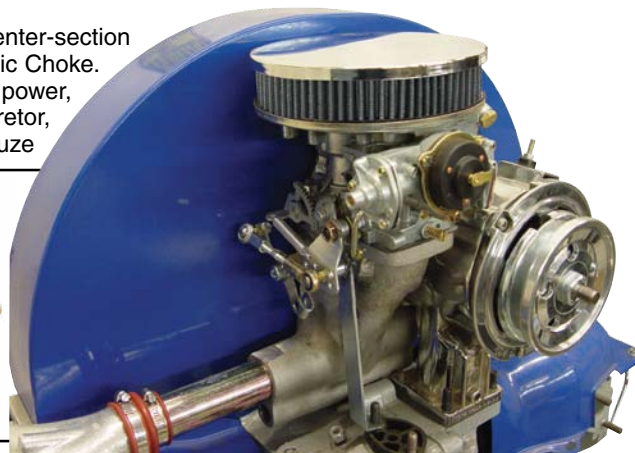

47-0628

- 47-0628 EMPI 38EGAS Single Carburetor Kit, Type 1 1300-1600
  - 47-0640 EMPI 38EGAS Single Carburetor Kit, Type 3
  - 47-0645 EMPI 38EGAS Single Carburetor Kit, Type 2 & 4 1700-2000
- 
- 47-0628-7 EMPI 38EGAS Carb Only



47-0640



47-0645



**NEW!**

## LOW PROFILE CHROME AIR CLEANER

Featuring 1 3/4" High Gauze filter element. Fits EMPI 38EGAS, Weber DGV, DGAV and DGEV carburetors.

**17-2981** **NEW!** 6 3/8" Low Profile Chrome Air Cleaner  
 (Replacement Air Cleaner for 47-0628, 47-0640 & 47-0645 Kits)



17-2980

## CARBURETOR SPACER FOR EPC/DFV/DGV

This die-cast aluminum plenum-style Spacer will add 5.5mm between your carb and manifold to help solve clearance issues for larger Alternators and/or other issues. Use with all EPC, DFV and DGV progressive and synchronous carburetors. Comes with 2 Plenum-cut Gaskets for installation.

**17-2980** Carburetor Spacer for EPC/DFV/DGV, 5.5mm, Set w/Gaskets





# INTAKE - CARB. KITS & COMPONENTS

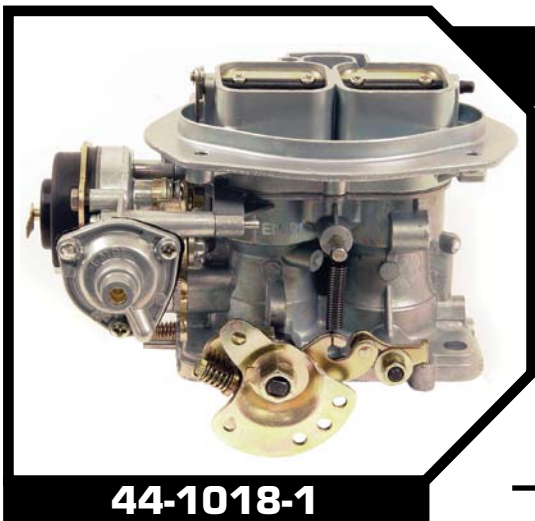

## [ EMPI EPC 32/36F ]

EMPI EPC 32/36 Carbs are supplied with these jets installed:

Auxiliary Venturi:	3.5	Primary Idle Jet:	.060
Needle Valve:	2.00	Secondary Idle Jet:	.050
Accel Pump Jet:	.55	Primary Air Jet:	1.65
Primary Main Jet:	1.37	Secondary Air Jet:	1.60
Secondary Main Jet:	1.40	Primary Emulsion Tube:	F-66
		Secondary Emulsion Tube:	F-50

**44-1018-1**

### EMPI EPC 32/36F PROGRESSIVE CARB KITS

Accelerate with 2-Barrel Performance...Cruise with 1-Barrel economy! Complete kits feature EMPI EPC 32/36F Carburetor with Electric Choke, Manifold, Chrome Air Cleaner with Gauze Element, Fuel Line, Hardware and Uni-Link Linkage kit.

**Test Run and Adjusted for smooth performance**

**All Carbs Test Run and Adjusted for smooth performance**



47-0622

### TYPE 1 & 2 PROGRESSIVE EMPI KITS

Isolated-Style Manifold for use with Dual or Single-Port End Castings. Fits Type 1 & 2 Upright Engine applications (See page 129 for End Castings). Jetted for Type 1 application.

**47-0622** EMPI Progressive EPC 32/36F Kit w/Air Cleaner

**44-1018-1** EMPI EPC 32/36F Carb. Only, Type 1 & 2

### MANIFOLDS & REPLACEMENT PARTS

These EMPI manifolds can be used with EMPI EPC 32/36F carbs, WEBER DFEV-DFAV carbs as well as Holley 5200 Series carbs.

**3232** Progressive Manifold Kit w/Tubes & Bracket, Isolated, Type 1 & 2, w/Hardware

**3232-7** Replacement Tubes & Brackets Only-for P/N: 3232, Bulk

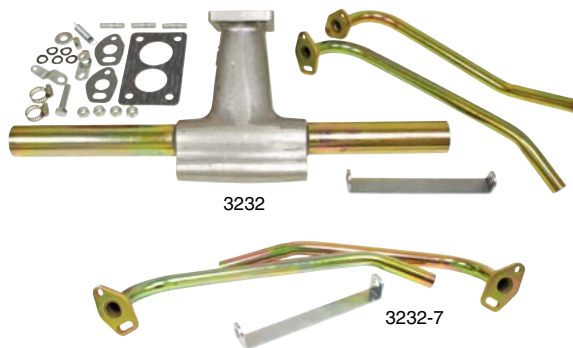

3232

3232-7



## EMPI EPC 32/36F PROGRESSIVE CARB KITS

Accelerate with 2-Barrel Performance...Cruise with 1-Barrel economy! Complete kits feature EMPI EPC 32/36F Carburetor with Electric Choke, Manifold, Chrome Air Cleaner with Gauze Element, Fuel Line, Hardware and Uni-Link Linkage kit (See page 81 for additional specifications).



47-0634

### TYPE 3 PROGRESSIVE EMPI KITS

Complete kit includes Deck Lid Bubble which is necessary to provide proper carburetor clearance. Requires cutting engine cover. Supplied with a jet package.

- 47-0634
- 47-0634-7
- 43-2125

- EMPI Progressive EPC 32/36F Kit w/Air Cleaner
- EMPI EPC 32/36F Carb. Only
- Replacement Deck Lid Bubble (Pictured in Kit)



47-0670

**These Jets provided for custom tuning T-3 and T-4 applications:**

- 1 - 1.70 Air Jet
- 1 - 1.80 Air Jet
- 1 - .045 Idle Jet
- 2 - F-6 Emulsion Tubes

### 1700-2000CC PROGRESSIVE EMPI KITS

Complete kit for installation on 1700, 1800 or 2000cc Type 2 & 4 engines. Fits both 3 & 4-Bolt Heads. Supplied with a jet package.

- 47-0670
  - 47-0670-7
- EMPI Progressive EPC 32/36F Kit w/Air Cleaner
  - EMPI EPC 32/36F Carb. Only



47-0800

### RABBIT/SCIROCCO PROGRESSIVE EMPI KITS

Complete kit comes with Carb. and Air Filter Adapter. For use with stock air cleaner. Supplied with a jet package.

- 47-0800
  - 47-0800-7
- EMPI Progressive EPC 32/36F Kit
  - EMPI EPC 32/36F Carb., Rabbit/Scirocco

### MANIFOLDS & REPLACEMENT PARTS

These EMPI manifolds can be used with EMPI EPC 32/36F carbs, WEBER DFEV- DFAV carbs as well as Holley 5200 Series carbs.



3244

3242

- 3241
  - 3242
  - 3244
- Progressive Manifold Kit, Type 3 & 4, w/Hardware
  - Manifold Runner Kit, Type 3, w/Hardware, Pair
  - Manifold Runner Kit, Type 4, w/Hardware, Pair



3241



43-0620

- 43-0620
- Replacement Electric Choke Element for EPC 32/36F, DFV/DFEV/DFAV



43-2130



43-2135

- 43-2130
  - 43-2135
- Replacement Carb. Adapter Kit, Rabbit/Scirocco, w/Hardware
  - Replacement Air Filter Adapter Kit, Rabbit/Scirocco, w/Hardware



# INTAKE - CARB. KITS & COMPONENTS

**EMPI BRAND CARBURETORS / ALL CARBS TEST RUN**

FREE EMPI  
TECH VIDEOS  
LOG ON TO EMPIUS.COM



47-1010 (40 HPMX)



47-1012 (44 HPMX)



44-1018-1 (EPC 32/36F)



43-1016-1 (EPC 34)



44-1001-1 (EPC 34X)



44-1551-1 (EPC 32/36E)



44-1017-1 (EPC 32/36E)



44-1017-2 (EPC 32/36A)



44-1017-3 (EPC 32/36A)



44-1017-4 (EPC 32/36M)



44-1005-1 (EPC 38E)



44-1006-1 (EPC 38E)



44-1551-2 (EPC 32/36M)



98-1288-B (30 PICT-1)



98-1289-B (34 PICT-3)



47-1048-0 (EPC 48)

**47-1010**  
**47-1010-2**  
**47-1012**  
**47-1012-2**

EMPI 40 HPMX Carb Only, w/Chrome Velocity Stacks for Dual Carb Set-Ups  
EMPI 40 HPMX Carb Only, w/Chrome Velocity Stacks for Single Carb Set-Ups  
EMPI 44 HPMX Carb Only, w/Chrome Velocity Stacks for Dual Carb Set-Ups  
EMPI 44 HPMX Carb Only, w/Chrome Velocity Stacks for Single Carb Set-Ups

**44-1018-1**

EMPI EPC 32/36F Progressive Carb Only, w/Electric Choke (Setup for V.W.)

**43-1016-1**

EMPI EPC 34 Carb Only

**44-1001-1**

EMPI EPC 34X Carb Only, 1 Barrel Replacement

**44-1551-1**

EMPI EPC 32/36E Carb Only, w/Electric Choke (Float Bowl Vent)

**44-1551-2**

EMPI EPC 32/36M Carb Only, w/Manual Choke (Float Bowl Vent)

**44-1017-1**

EMPI EPC 32/36E Carb Only, w/Electric Choke

**44-1017-2**

EMPI EPC 32/36A Carb Only, w/Water Choke (Toyota Design)

**44-1017-3**

EMPI EPC 32/36A Carb Only, w/Water Choke (Suzuki Design)

**44-1017-4**

EMPI EPC 32/36M Carb Only, w/Manual Choke

**44-1005-1**

EMPI EPC 38E Carb Only, w/Electric Choke

**44-1006-1**

EMPI EPC 38E Carb Only, w/Electric Choke (Float Bowl Vent)

**47-0628-7** **NEW!**

EMPI EPC 38E Carb Only, w/Electric Choke (Set Up for VW)

**47-1048**

EMPI EPC 48 Carb Only, w/ Aluminum Velocity Stacks, w/ Enlarged Float Bowl and 3rd Progression Holes

**47-1050**

EMPI EPC 51 Carb Only, w/ Aluminum Velocity Stacks, w/ Enlarged Float Bowl and 3rd Progression Holes

**98-1288-B**

EMPI 30 PICT-1 Carb Only, Gasket and Studs included (Score Approved)

**98-1289-B**

EMPI 34 PICT-3 Carb Only, Gasket and Studs included

**98-1287-B**

EMPI 30 PICT-1 Modified Carb Only, Gasket and Studs included (Score Approved) Off-Road Only



47-1050-0 (EPC 51)



98-1287-B (Modified 30 PICT-1)  
Off-Road Only

**All Carbs  
Test Run**



43-1012  
(44 IDF)

## EMPI VW WEBER IDF CARB KITS - TYPE 1

Performance, reliability and race proven for decades. WEBER Carbs. offer ultimate engine tuning with total air and fuel metering and adjustment. The IDF-XE Plus series IDF's have separate idle and main circuits featuring changeable air and fuel jets. Intake air is metered by changeable venturies and accelerator pump is adjustable for maximum acceleration. Jets, gaskets and repair parts are readily available world wide. All our kits are pre-jetted for VW engines. Choose the appropriate size carburetor for your application. When future engine modification is planned, size-up now! Basic rule of thumb...

- 40mm Carbs. for engines up to 1800cc\*
- 44mm Carbs. for engines up to 2200cc



44 IDF carbs come with steel velocity stacks. 40 IDF carbs DO NOT come with velocity stacks.

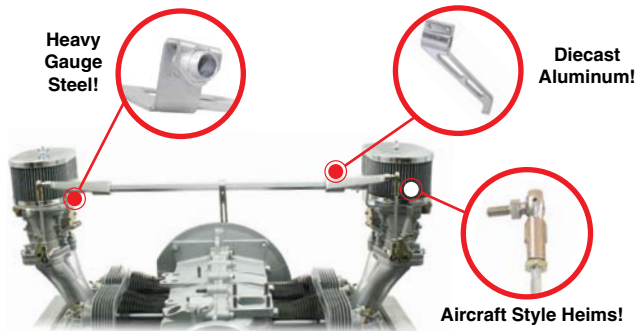

## EMPI DUAL WEBER IDF HEXBAR CARBURETOR KITS

The EMPI WEBER Hex Bar IDF Carburetor Kits have many of the features of our Deluxe WEBER Kits. All Kit features:

Aluminum Alloy Hex Bar with Steel Ball Ends - **Sealed Aircraft Heim Rod Ends** - Offset Aluminum Intake Manifolds - **Thick High Strength Steel Linkage Mounts** - Chrome Air Filters with High Flow Gauze Elements - **Coil Relocation Mount** - Brass Fuel Tee - **Detailed and Illustrated Instructions** - Attractive EMPI Packaging.



43-7319

## DUAL WEBER IDF CARBURETOR KITS WITH AIR CLEANERS

### 1500-1600cc Based Up-Right Engines

- 43-7317\* EMPI Dual 40 IDF Carb. Kit w/Air Cleaners
  - 43-7319 EMPI Dual 44 IDF Carb. Kit w/Air Cleaners
- \*40 IDF carbs DO NOT come with velocity stacks.

## DUAL WEBER IDF CARBURETOR KITS WITHOUT AIR CLEANERS

### 1500-1600cc Based Up-Right Engines

- 43-6317\* EMPI Dual 40 IDF Kit w/o Air Cleaners
  - 43-6319 EMPI Dual 44 IDF Kit w/o Air Cleaners
- \*40 IDF carbs DO NOT come with velocity stacks.



43-6319

## WEBER CARBURETOR ONLY

- 43-1010\* 40 IDF Carburetor Only
  - 43-1012 44 IDF Carburetor Only
- \*40 IDF carbs DO NOT come with velocity stacks.



# INTAKE - CARB. KITS & COMPONENTS

## EMPI VW DELUXE WEBER IDF CARB KITS - TYPE 1

EMPI's Deluxe WEBER Carburetor kits are the finest available. We have re-engineered them to offer many outstanding features not found in other kits. Features include:



Aluminum Alloy Hex Bar with Steel Ball Ends - **Sealed Aircraft Heim Joint Rod Ends** - Ball Burnished/Polished Offset Aluminum Intake Manifolds - Thick High Strength Steel Linkage Mounts - **Solid Aluminum Base/Top Air Cleaner Assemblies** - High Flow Gauze Elements - **Coil Relocation Mount** - Brass Fuel Tee - **Fuel Filter** - Brass Manifold Nuts - **Detailed Illustrated Instructions** - Attractive EMPI Packaging.

**Billet 6061 T-6 Aluminum A/C Assemblies**



43-9319

### DELUXE DUAL WEBER IDF CARBURETOR KITS WITH **BILLET ALUMINUM** AIR CLEANER ASSEMBLIES

1500-1600cc Up-Right Based Engines

- 43-9317\* EMPI Deluxe Dual 40 IDF Carb. Kit
- 43-9319 EMPI Deluxe Dual 44 IDF Carb. Kit

**\*40 IDF carbs DO NOT come with velocity stacks.**

**44 IDF carbs come with steel velocity stacks.  
40 IDF carbs DO NOT come with velocity stacks.**

### DELUXE DUAL WEBER IDF CARBURETOR KITS WITH **CHROME STEEL** AIR CLEANER ASSEMBLIES

1500-1600cc Up-Right Based Engines

- 43-8317\* EMPI Deluxe Dual 40 IDF Carb. Kit
- 43-8319 EMPI Deluxe Dual 44 IDF Carb. Kit

**\*40 IDF carbs DO NOT come with velocity stacks.**



43-8319

### WEBER CARBURETOR ONLY

- 43-1010\* 40 IDF Carburetor Only
- 43-1012 44 IDF Carburetor Only

**\*40 IDF carbs DO NOT come with velocity stacks.**

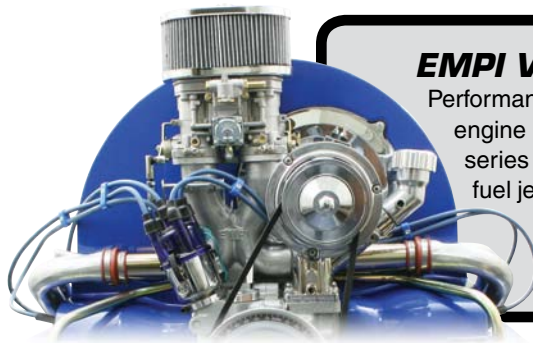

## EMPI VW WEBER IDF CARB KITS - TYPE 1, 2, 3 & 4

Performance, reliability and race proven for decades. WEBER Carbs. offer ultimate engine tuning with total air and fuel metering and adjustment. The IDF-XE Plus series IDF's have separate idle and main circuits featuring changeable air and fuel jets. Intake air is metered by changeable venturies and accelerator pump is adjustable for maximum acceleration. Jets, gaskets and repair parts are readily available world wide. All our kits are pre-jetted for VW engines.

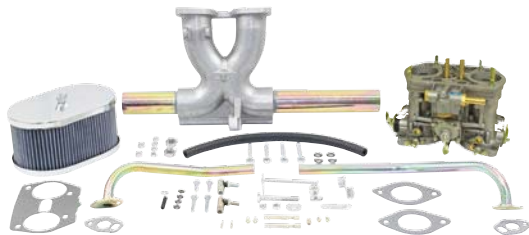

43-7315 (Type 1)

### SINGLE WEBER IDF TYPE 1 CARB. KITS WITH AIR CLEANER

For those that choose ease of maintenance along with performance gains, the single 40/44 IDF is the set-up of choice. For the basic 1600-1800cc, the 40 IDF Kit is a torquey option. For all out performance, the way to go is the 44 IDF. Both carb. kits come with an assortment of jets to tune your carburetor. EMPI also has available a selection of jets if your application requires further "dialing in". Complete kits feature Aluminum Center-Section Manifold, Aircraft Style Heim Joint Linkage, Chrome Air Cleaner with gauze element, gaskets and hardware. Complete with detailed illustrated instructions and attractive EMPI packaging. Fits Type 1 1600cc based upright engines.

(Requires P/N: 3236 dual port end kit or P/N: 3237 single port end kit).

### 1500-1600cc Based Up-Right Engines (NEW ISOLATED MANIFOLD)

**43-7315\*** EMPI Single 40 IDF Kit w/Air Cleaner

**43-7316** EMPI Single 44 IDF Kit w/Air Cleaner

**\*40 IDF carbs DO NOT come with velocity stacks.**

**43-1010\*** 40 IDF Carb. Only, Each  
(Additional Jetting Required, Inquire)

**43-1012** 44 IDF Carb. Only, Each  
(Additional Jetting Required, Inquire)

**\*40 IDF carbs DO NOT come with velocity stacks.**



43-7341 (Type 3)

### DUAL WEBER IDF TYPE 3 CARB. KITS

**43-7341\*** EMPI Dual 40 IDF Kit w/Air Cleaners

**43-7342** EMPI Dual 44 IDF Kit w/Air Cleaners

**\*40 IDF carbs DO NOT come with velocity stacks.**



### DUAL WEBER IDF CARBURETOR KITS FOR TYPE 2/4

The same rules apply to 1700-2000cc pancake engines as they do to Type 1 engines. Install a set of IDF WEBERS, sit back, hang-on and enjoy the performance gains. All EMPI Type 2/4 kits feature all the same high quality hardware and components as our other standard Dual IDF kits. Choose the size of carburetor that best fits your application. Comes complete with detailed installation instructions and EMPI packaging. All kits come with hardware for complete installation on Porsche 914's as well.



43-7295 (Type 2/4)

### 1700-2000cc Type 2/4 & 914 Engines

**43-7347\*** EMPI Dual 40 IDF Carb. Kit for 1700-1800cc w/Air Cleaners

**43-7295** EMPI Dual 44 IDF Carb. Kit for 2000cc w/Air Cleaners

**\*40 IDF carbs DO NOT come with velocity stacks.**

### DUAL WEBER IDF CARB. KIT FOR PORSCHE 356/912 ENGINE

**44-1291\*** Dual 40 IDF Carb. Kit for Porsche 356/912

**44-1292** Dual 44 IDF Carb. Kit for Porsche 356/912

**\*40 IDF carbs DO NOT come with velocity stacks.**



44-1292 (Porsche)



# INTAKE - CARB. KITS & COMPONENTS

## EMPI VW DUAL WEBER ICT CARB KITS - TYPE 1, 2, 3 & 4

If improving performance without sacrificing fuel economy is your desire, then the EMPI WEBER Dual 34 ICT Kits are the way to go. All Kits feature:

- Aluminum Alloy Hex Bar with Steel Ball Ends - Sealed Aircraft Heim Rod Ends - High Flow Aluminum Intake Manifolds - Thick High Strength Steel Linkage Mounts - Gauze High Flow Air Cleaner Assemblies - Coil Relocation Mount - Brass Fuel Tee - Detailed and Illustrated Instructions - Attractive EMPI Packaging.

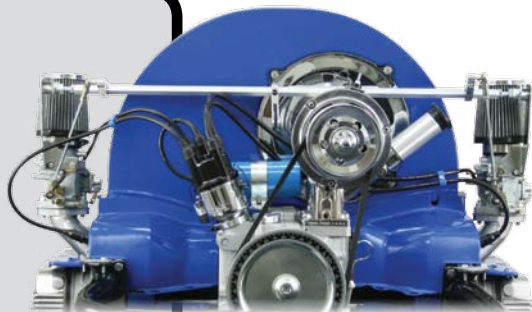

### EMPI DUAL WEBER 34 ICT

We supply these Carburetors with the following already installed:

- 1.75 Needle and Seat
- .130 Main Jet
- .52 Idle Jet
- .160 Air Correction Jet
- F-7 Emulsion Tubes

### DUAL WEBER 34 ICT FOR TYPE 1

#### 1500-1600cc Up-Right Based Engines

- 43-7401 EMPI Dual WEBER 34 ICT Kit, Type 1 Single Port w/Air Cleaners
- 43-7411 EMPI Dual WEBER 34 ICT Kit, Type 1 Dual Port w/Air Cleaners
- 43-1016 34 ICT Carb. Only, Each



43-7411



### DUAL WEBER 34 ICT FOR TYPE 3 ENGINES

- 43-7301 EMPI Dual WEBER 34 ICT Kit, Type 3 Single Port w/Air Cleaners
- 43-7311 EMPI Dual WEBER 34 ICT Kit, Type 3 Dual Port w/Air Cleaners
- 43-1016 34 ICT Carb. Only, Each



43-7311

### DUAL WEBER 34 ICT FOR TYPE 2/4, 914 ENGINES

- 43-7412 EMPI Dual WEBER 34 ICT Kit, 1700-2000cc Type 2/4 & 914 Engines w/Air Cleaners
- 43-1016 34 ICT Carb. Only, Each



43-7412

# INTAKE - CARB. KITS & COMPONENTS



## EMPI VW WEBER 48 IDA CARB KITS

EMPI has been instrumental in the re-introduction of the ever popular WEBER 48IDA. These are the latest production version model # 48IDA 4R. They are the 2-hole bypass style and come right out of the box with 37mm Venturi's and jet screens already installed. If all-out horsepower is your main concern, EMPI 48IDA's are the best WEBER available for the job. Choose from kits, carburetors only or components, EMPI has them all available.



### DUAL 48 IDA KITS FOR TYPE 1

All EMPI dual 48IDA kits come with competition cross-bar linkage. All our kits are supplied with both the aluminum crossbar mounts at the velocity stacks and steel mounts which allow for air cleaner use. "Standard" intake manifolds are clearanced for the area around the upper intake port at head and sheetmetal to limit modifications for installation, but still allowing for match porting with no additional welding required. **The "Race" intake manifolds are for all-out racing head use with more material provided at upper intake port area, so the manifold can be match ported to even the most extensively modified head.** Both manifolds have the same basic "Stock" port design at the base of the manifold so they can be precisely match ported to your particular port shape. (Kits are not supplied with air cleaners). [\(Air cleaners can be seen on page 100\).](#)

- 43-7328 Dual 48 IDA, Type 1, w/Std. Manifolds (Kit supplied with 43-5240 Linkage)
- 43-7329 Dual 48 IDA, Type 1, w/Race Manifolds (Kit supplied with 43-5240 Linkage)
- 43-7332 Dual 48 IDA, Type 1, w/Std. Manifold, (Kit supplied with 43-5242 Hex Bar Linkage)
- 43-7333 Dual 48 IDA, Type 1, w/Race Manifold, (Kit supplied with 43-5242 Hex Bar Linkage)
- 43-1048 48 IDA Carburetor Only, Each



43-7329

### LINKAGE AND MANIFOLDS

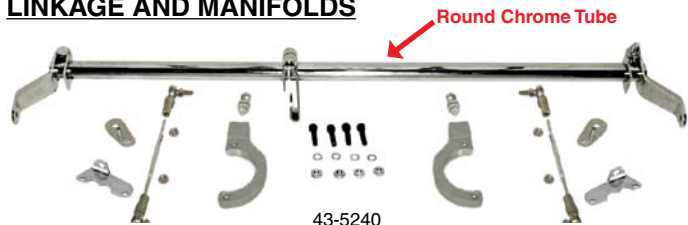

43-5240



43-5242

- 43-5240 EMPI EPC 48/51 and Weber 48 IDA Linkage Kit (Works with and without Air Cleaners)
- 43-5242 EMPI EPC 48/51 and Weber 48 IDA Hex Bar Linkage Kit (Works with and without Air Cleaners)



43-5215

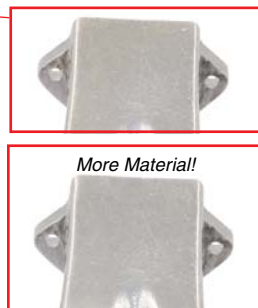

43-5214

- 43-5214 EMPI EPC 48/51 and Weber 48 IDA Racing Manifolds, Pair
- 43-5215 EMPI EPC 48/51 and Weber 48 IDA Std. Manifolds, Pair





# INTAKE - CARB. KITS & COMPONENTS

## **PROGRESSIVE WEBER CARB KITS**

Accelerate with 2-Barrel Performance...Cruise with 1-Barrel economy! Complete kits feature WEBER Carburetor with Electric Choke, Manifold, Chrome Air Cleaner with Gauze Element, Fuel Line, Hardware and Uni-Link Linkage kit.

### **TYPE 1 & 2 PROGRESSIVE WEBER KITS**

Isolated-Style Manifold for use with Dual or Single-Port End Castings. Fits Type 1 & 2 Upright Engine applications. Jetted for Type 1 application. (See page 129 for End Castings)



- 43-0622 EMPI Deluxe Progressive WEBER Kit w/Air Cleaner
- 43-0622-7 WEBER DFEV Carb. Only, Type 1 & 2

### **TYPE 3 PROGRESSIVE WEBER KITS**

Complete kit includes Deck Lid Bubble which is necessary to provide proper carburetor clearance. Requires cutting engine cover. Supplied with a jet package.



- 43-0634 EMPI Deluxe Progressive WEBER Kit w/Air Cleaner
- 43-0634-7 WEBER DFEV Carb. Only
- 43-2125 Replacement Deck Lid Bubble

### **1700-2000CC PROGRESSIVE WEBER KITS**

Complete kit for installation on 1700, 1800 or 2000cc Type 2 & 4 engines. Fits both 3 & 4-Bolt Heads. Supplied with a jet package.



- 43-0670 EMPI Deluxe WEBER Progressive Kit w/Air Cleaner
- 43-0670-7 WEBER DFEV Carb. Only

### **RABBIT/SCIROCCO PROGRESSIVE WEBER KITS**

Complete kit comes with Carb. and Air Filter Adapter. For use with stock air cleaner. Supplied with a jet package.



- 43-0800 EMPI Deluxe WEBER Progressive Kit
- 43-0800-7 WEBER DFEV Carb., Rabbit/Scirocco

## **MANIFOLDS & REPLACEMENT PARTS**

These EMPI manifolds can be used with EMPI EPC 32/36F carbs, WEBER DFEV-DFAV carbs as well as Holley 5200 Series carbs.

- 3232 Progressive Manifold Kit w/Tubes & Bracket, Isolated, Type 1 & 2, w/Hardware
- 3232-7 Replacement Tubes & Brackets Only-for P/N: 3232, Bulk
- 3241 Progressive Manifold Kit, Type 3 & 4, w/Hardware
- 3242 Manifold Runner Kit, Type 3, w/Hardware, Pair
- 3244 Manifold Runner Kit, Type 4, w/Hardware, Pair
- 43-0620 Replacement Electric Choke Element for EPC 32/36F, DFV/DFAV/DFAV
- 43-2130 Replacement Carb. Adapter Kit, Rabbit/Scirocco, w/Hardware
- 43-2135 Replacement Air Filter Adapter Kit, Rabbit/Scirocco, w/Hardware





43-1010 (40 IDF)

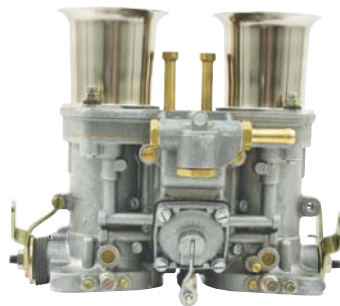

43-1012 (44 IDF)



43-1016 (34 ICT)

## WEBER CARBURETORS

EMPI is your source for WEBER carburetors.



43-1010

40 IDF Carburetor Only  
**Supplied without velocity stacks**

43-1012

44 IDF Carburetor Only

43-1016

34 ICT Carburetor Only

43-1048

48 IDA Carburetor Only



43-1048 (48 IDA)



43-0622-7 (32/36 DFEV)

43-0622-7

32/36 DFEV Carb. Only, **(Electric Choke), Universal and VW Applications**



## UNIVERSAL CABLE ADAPTER

Throttle Cable to Carburetor made easy with this simple yet effective Universal Cable Adapter. One end features a heim joint with 10/32" stud to bolt to your carburetor linkage arm. The other end has an adjustable cable nut to secure your throttle cable end. A simple adapter that can become the perfect solution for many carburetor applications.

43-0605

Universal Cable Adapter, Set



43-5712

5746

## CARBURETOR SYNCHRONIZERS

Proper synchronization of dual carburetor set-ups is essential for peak performance. Accurately dial in your carbs with one of these Carburetor Synchronizers. Our P/N: 5746 is the original, SU type, bubble gauge with pivoting gauge tube for down-draft or side-draft applications. P/N: 43-5712 includes two Adapters which allows for 1-tool usage on a wide spectrum of applications. The Pro-Synchronizer will not restrict airflow and feature an easy to read 1-30 kg/h numbered scale for precise synchronization.

43-5712  
5746

EMPI Universal Pro-Sync, w/2 Adapters  
SU Type Carburetor Synchronizer

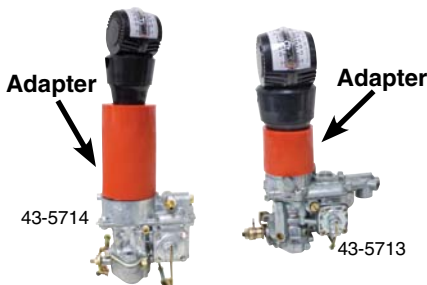

43-5714

43-5713

## CARBURETOR SYNCHRONIZER URETHANE ADAPTERS

Dialing in your Dual EPC34s, Weber ICTs and Solex/Brosol just got a bit easier! These urethane adapters are made specifically for these carburetors. With easy push-on fit, they are impervious to gas and oil. Even the Solex/Brosol Adapter fits without removing the air cleaner center stud. For use with P/N 43-5712 EMPI Universal Pro-Sync.

43-5713  
43-5714

Synchronizer Adapter 34EPC/34ICT Carburetors, Each  
Synchronizer Adapter Solex/Brosol Carburetors, Each



# INTAKE - CARB. KITS & COMPONENTS

## HPMX/IDF MANIFOLD & LINKAGE KITS

Individual components allow you to tailor fit a carb kit that's right for you. These manifold and linkage kits are the same high quality components used in our complete carb. kits.



## MANIFOLD KITS & MANIFOLDS

High quality aluminum manifolds. All necessary hardware and gaskets are included.

**43-1019** Std. EMPI Dual HPMX or IDF Manifold Kit for Type 1 (Used on P/N 43-6317, 43-6319, 43-7317, 43-7319, 47-6317, 47-6319, 47-7317, 47-7319 Series Kits) Ball Burnished Finish. Has extra material for porting **May not fit with stock fan shroud without modification.**

**43-5209** EMPI Deluxe Dual HPMX or IDF Manifold Kit for Type 1 (Used on P/N 43-8317, 43-8319, 43-9317, 43-9319, 47-8317, 47-8319, 47-9317, 47-9319 Series Kits) Ball Burnished Finish **Fits with most stock fan shrouds with little or no modification.**

**43-5208** EMPI Single HPMX or IDF Manifold Kit for Type 1 (Ball Burnished Finish) **Isolated Design, Complete with Linkage Kit**

**43-5208-8** Replacement Linkage Kit only for 43-5208

**43-5210** EMPI Dual HPMX or IDF Manifold Kit for 1700-2000cc Type 2/4 & 914 (Ball Burnished Finish)

**43-5213** EMPI Dual HPMX or IDF Manifold Kit for Type 3 (Ball Burnished Finish)

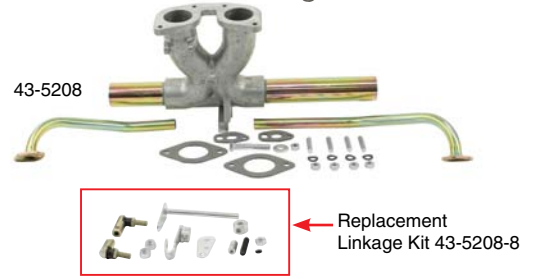

## HEX BAR LINKAGE KITS

High quality linkage kits feature thick heavy duty mounting plates, aircraft quality heims and include all necessary hardware and gaskets.

**43-5223** EMPI HPMX or IDF Hex Bar Linkage Kit for Type 1 & Type 3 (Used on P/N 43-6317, 43-6319, 43-7317, 43-7319, 47-6317, 47-6319, 47-7317, 47-7319 Series Kits)

**43-5224** EMPI HPMX or IDF Hex Bar Linkage Kit for 1700-2000cc Type 2/4 & 914

**43-5230** EMPI HPMX or IDF Hex Bar Linkage Kit for Type 1 (Used on P/N 43-8317, 43-8319, 43-9317, 43-9319, 47-8317, 47-8319, 47-9317, 47-9319 Deluxe Series Kits)

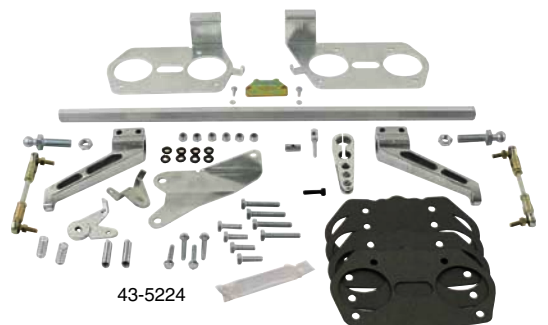



## ***EPC 34/ICT MANIFOLD & LINKAGE KITS***

Individual components allow you to tailor fit a carb kit that's right for you. These manifold and linkage kits are the same high quality components used in our complete carb kits. See page 78 for Tall 34 EPC / ICT Manifold Kit.

### **MANIFOLD KITS**

High quality aluminum manifolds. All necessary hardware and gaskets are included.



43-5205

**43-5205**

EMPI EPC 34 or ICT Manifold Kit for Single Port Type 1 & 3



43-5206

**43-5206**

EMPI EPC 34 or ICT Manifold Kit for Dual Port Type 1 (Ball Burnished Finish)



43-5212

**43-5212**

EMPI EPC 34 or ICT Manifold Kit for Dual Port Type 3 (Ball Burnished Finish)



43-5207

**43-5207**

EMPI EPC 34 or ICT Manifold Kit for 1700-2000cc Type 2/4 & 914 Engines (Ball Burnished Finish)



43-5220

### **HEX BAR LINKAGE KITS**

High quality linkage kits feature thick heavy duty mounting plates, aircraft quality heims and include all necessary hardware and gaskets.

**43-5220**

EMPI EPC 34 or ICT Hex Bar Linkage Kit for Type 1



43-5221

**43-5221**

EMPI EPC 34 or ICT Hex Bar Linkage Kit for Type 3



43-5222

**43-5222**

EMPI EPC 34 or ICT Hex Bar Linkage Kit for 1700-2000cc Type 2/4 & 914 Engines



# INTAKE - CARB. KITS & COMPONENTS

## UNIVERSAL TYPE 1 TWIST STYLE DUAL CARBURETOR LINKAGE

Twist Style Dual Carb Linkage for dual EMPI HPMX / EPC-34 / EPC-48 / EPC-51, Weber IDF / ICT / IDA, Dellorto and Solex/Brosol dual carburetors featuring the best and strongest combination of components: Billet aluminum center stand, 5/16" steel pivot bolt, steel linkage pivot, 3/8" aluminum linkage rods with adjustable Heim Joints and two sets of stamped steel carburetor linkage arms to accommodate EMPI, Weber, Dellorto and Solex/Brosol and other carburetors. Rods may need to be cut to fit certain carburetors.

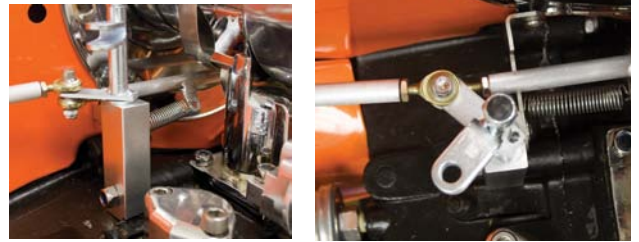

17-2945 Universal Twist Style Dual Carb Linkage, Type 1 1300-1600



17-2945

## HEX BAR LINKAGE NEEDLE BEARING CONVERSION KIT

Retrofits all EMPI Hex Bar Linkage to upgrade from the Ball & Bushings ends to Needle Bearing for smooth operation and reliability. Helps maintain carburetor and linkage adjustment and synchronization. Easy installation.

44-1127 **NEW!** Hex Bar Linkage Bearing Conversion Kit for EMPI Hex Bar Linkage Kits



Unit Installed

## TALL HPMX / IDF MANIFOLD KIT

These manifolds are cast with the NOS Bosses. Complete with all hardware and gaskets. Has extra material for porting.

18-1061 **NEW!** EMPI Dual HPMX or IDF Manifold Kit for Type 1



## 356/912 PORSCHE MANIFOLD KIT

These trick manifolds allow the owners of early 356/912 Porsches to adapt either 40/44 HPMX or 40/44 IDF carbs to their stock engines. The conversion looks clean and fits in the engine compartment nicely. Gaskets, studs and hardware are included.

48-1295 **NEW!** Dual Manifolds, 356/912, 40/44 HPMX and IDF, Pair



## 356/912 PORSCHE SOLEX 40P11 TO HPMX/IDF CARBURETOR ADAPTORS

Porsche 356 and 912 used Solex 40P11 carburetors that have become impossible to rebuild or service. These adaptors make it easy to switch to HPMX or IDF carburetors using them with your stock manifolds. Gaskets, studs and hardware are included.

48-1293 **NEW!** Dual Carburetor Adaptors w/Hardware HPMX/IDF to 356/912, Pair



48-1293



## LINKAGE COMPONENTS

A selection of the most commonly asked for replacement linkage components. Lost, broken or worn, now you can more easily identify and order the pieces you need to complete your linkage.



43-1060

**43-1060** **NEW!** Linkage Ball End Bushings, Pr.  
These plastic bushings fit all of EMPI Dual Carb Kits for 40/44 HPMX/IDF, 34EPC/ICT with ball ends.



43-1061

**43-1061** **NEW!** Linkage Heim Ends, 10/32 Left & Right, Pr.  
These Right & Left Heim Ends are used on most EMPI Dual Carb Kits.



43-5904

**43-5904** **NEW!** 40/44 HPMX/IDF **Type 1** Linkage Down Rod with Heim Ends, Short (4 1/2"), Set  
Hexrod Assembly used in the following Linkage / Carburetor Kits  
For Kit P/N: 43-5223, 43-5230, 43-6317, 43-6319, 43-7317, 43-7319, 43-8317, 43-8319, 43-9317, 43-9319, 43-9317, 47-6317, 47-7317, 47-7319, 47-7332, 47-7335, 47-7336, 47-8317, 47-8319, 47-9317 and 47-9319



43-5905

**43-5905** **NEW!** 34EPC/ICT **Type 1** Linkage Down Rod with Heim Ends, Long (6 1/2"), Set  
Hexrod Assembly used in the following Linkage / Carburetor Kits  
For Kit P/N: 43-5220, 43-7401, 43-7411, 47-7401 and 47-7411



43-5907

**43-5907** **NEW!** 34EPC/ICT **Type 3 & 4** Linkage Down Rod with Heim Ends, (1 3/4") Set  
Hexrod Assembly used in the following Linkage / Carburetor Kits  
For Kit P/N: 43-5221, 43-5222, 43-7301, 43-7311, 43-7412, 47-7301, 47-7311 and 47-7412



43-5908

**43-5908** **NEW!** 40/44 HPMX/IDF **Type 3**, 48-51EPC/IDA Linkage Down Rod with Heim Ends, (3 1/2"), Set  
Hexrod Assembly used in the following Linkage / Carburetor Kits  
For Kit P/N: 43-5240, 43-5242, 43-7328, 43-7329, 43-7332, 43-7333, 43-7341, 43-7342, 47-7328, 47-7329, 47-7330, 47-7331, 47-7341, 47-7342, 47-7429



43-1063

**43-1063** **NEW!** Linkage Down Rod Extensions, Short & Long, Pr  
These extensions are used on all of EMPI Dual Carb Kits for 40/44 HPMX/IDF and 34EPC/ICT.



43-1062

**43-1062** **NEW!** Linkage Ball Socket Ends, 10/32 Left & Right, Pr  
These socket ends are used on EMPI/Brosol Carb Kits.



## POLISHED BILLET ALUMINUM CARBURETOR DISPLAY STAND

The same Billet Carburetor Display Stand made for our displays at SEMA and other shows is now available for your showroom. Solid Polished Billet Aluminum Base is designed for display any EMPI Dual Carburetor Kit or any EMPI Single Carburetor Kit with use of EMPI Dual Port End Castings. Studs included.

NEW!



**2059** **NEW!** Aluminum Carburetor Display Stand, Dual Port



# INTAKE - CARB. KITS & COMPONENTS

## EMPI 40MM DUAL **BROSOL / SOLEX** TYPE 1 CARBURETOR KIT



43-4416

### EMPI 40 DUALS FOR TYPE 1 DUAL PORT

Dual 40 Carb kits featuring Brosol/Solex 40mm carbs, cast EMPI manifolds, chrome top air cleaners with washable gauze filters – but now with your choice of Original-Style Linkage or the **NEW EMPI Twist Linkage**, featuring Heim ends, Billet stand and 3/8" aluminum rods - better performance, easier set-up and linkage stays adjusted!

**43-4416** EMPI Deluxe Dual 40mm Carb Kit w/EMPI Twist Linkage, Type 1

**43-4400** **ORIGINAL** EMPI Dual Carb. Kit, Type 1, Dual Port



43-4400

Carbs supplied with the following Jets installed...  
Idle Jet - 55, Main Jet - 130, Air Jet\* - 150  
\*Air Jet cannot be changed. Must be drilled.



New Twist Linkage

**Now Available in 44mm & Electric Choke Versions**

See page 93 & 97 for further pictures.



43-4417

## EMPI'S **BROSOL / SOLEX** JUST GOT BIGGER AND BETTER!

EMPI has raised the bar on the competition for single throat high performance dual carburetor kits. We have taken the great performing 40mm Brosol/Solex and enlarged it to a true high flowing 44mm carburetor. Along the way, we added a 12-Volt electric choke to the new 44mm carburetors so that these new dual carburetor kits can now be fully utilized for cold weather climates. If your existing dual Solex's feel like they could use a little more "punch" or you like the idea of smooth cold starting then upgrade now to a new version of an EMPI Solex/Brosol 44mm dual carburetor kit. Fits all Type 1 & 2 dual port upright 1600cc based engines. These kits utilize the same outstanding manifolds, linkage, air cleaners, hardware, etc. that our "tried and true" P/N: 43-4400 kit uses. Now available with the **NEW EMPI Twist Linkage**. Suggested for 2000cc and larger engines.

Carbs supplied with the following Jets installed...Idle Jet - 60, Main Jet - 145, Air Jet\* - 150 \*Air Jet cannot be changed. Must be drilled.



43-4420

- 43-4417** EMPI Deluxe Dual 44mm Carb Kit w/EMPI Twist Linkage, Type 1
- 43-4420** EMPI Dual 44mm Carb Kit, Type 1
- 43-4418** EMPI Deluxe Dual 44mm Carb Kit w/EMPI Twist Linkage & Electric Chokes, Type 1
- 43-4426** EMPI 44mm Dual Carb Kit w/Electric Choke, Type 1



Now Available in a 44mm Big Bore Version!



Now Available with Electric Choke!



## **EMPI 40MM & 44MM DUALS *BROSOL / SOLEX* FOR 1.7-2.0 TYPE 2**

The EMPI Dual 40mm carburetor kit has been considered a reliable replacement and a great performance upgrade for a troublesome stock carburetor setup or fuel injection system. With the advent of the EMPI 44mm electric choke Brosol/Solex along with the 44mm non-electric choke carburetors your choices for an upgrade just got larger and broader. For 1.7 – 1.8 motors choose from the 40mm non-electric choke models, these dual carburetor kits will give you crisp throttle response along with great fuel economy. If you have a hi-performance application or a 2.0 or bigger engine then go with the 44mm dual carburetor setup. Then decide if non-electric choke all out performance is what you want or if cold weather smooth running is important choose the 44mm electric choke version. All kits come complete with carburetors, manifolds, linkage kit, hose, gaskets, hardware and detailed instructions.

- 43-4500**            EMPI 40mm Dual Brosol / Solex Kit for 1.7–1.8L Type 2's
- 43-4520**            EMPI 44mm Dual Brosol / Solex Kit, for 2.0L Type 2's
- 43-4526**            EMPI 44mm Dual Brosol / Solex Kit w/Electric Choke for 2.0L Type 2's







# INTAKE - CARB. KITS & COMPONENTS

## UNIVERSAL TYPE 1 TWIST STYLE DUAL CARBURETOR LINKAGE

Twist Style Dual Carb Linkage for dual EMPI HPMX / EPC-34 / EPC-48 / EPC-51, Weber IDF / ICT / IDA, Dellorto and Solex/Brosol dual carburetors featuring the best and strongest combination of components: Billet aluminum center stand, 5/16" steel pivot bolt, steel linkage pivot, 3/8" aluminum linkage rods with adjustable Heim Joints and two sets of stamped steel carburetor linkage arms to accommodate EMPI, Weber, Dellorto and Solex/Brosol and other carburetors. Rods may need to be cut to fit certain carburetors.

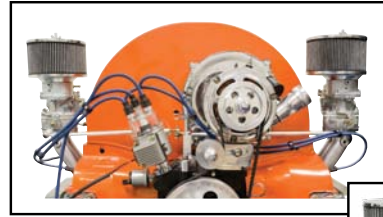

**17-2945** Universal Twist Style Dual Carb Linkage, Type 1 1300-1600



17-2945

## REPLACEMENT COMPONENTS FOR TYPE 1 & TYPE 2 EMPI BROSOL / SOLEX KITS

### TYPE 1 DUAL LINKAGE KIT

Whether it's an upgrade or just time to replace a worn out old linkage, this kit has everything necessary to put your EMPI Brosol / Solex carburetors back in synchronous operation.

**43-4410** Replacement EMPI Linkage Kit, (Also fits older Kadron Kits)



43-4410

### TYPE 1 DUAL PORT MANIFOLDS

These manifolds can be used to retro-fit to an old Kadron kit or upgrade an existing setup. Comes complete with aluminum manifolds, crossover hose, fittings, gaskets and all necessary hardware.

**43-4412** EMPI Alum. Dual Port Manifold Kit, Pair



43-4412

### AIR CLEANER KITS & ELEMENTS

These are the same high quality Air Cleaners we supply with our P/N : 43-4400 & 43-4500 series EMPI Dual 40mm & 44mm Carburetor Kits. Features washable gauze element & hardware.

**8801** EMPI Air Cleaner Kit, 3 3/4" High, Pair  
**8802** Replacement Gauze Element, 3 1/2" High, Each

**43-4460** Single Air Cleaner for 40/44 EMPI/Brosol/Solex Carbs, 3 3/4" High, 2 3/8" Neck, Each



8801



43-4460



8802



## SERVICE ITEMS FOR EMPI 40MM & 44MM BROSOL / SOLEX CARBURETORS



43-5211

### TYPE 2 MANIFOLD KIT

This kit utilizes the same high quality aluminum castings used in our 40mm & 44mm EMPI Brosol / Solex dual carburetor kits. Comes complete with all necessary hardware and gaskets.

43-5211 EMPI Manifold Kit for P/N: 43-4500/20/25/26



43-5225

### TYPE 2 LINKAGE KIT

Featuring the same components that are included in our dual carb type 2 kits. This linkage kit is complete with all necessary items for replacement use on an existing dual carburetor kit.

43-5225 EMPI Linkage Kit for P/N: 43-4500/20/25/26



43-4403

### FLOAT

If your carburetors have brass floats, we now offer the upgraded plastic versions. Use these and say good bye to sinking floats.

43-4403 Replacement Float, Plastic, Each



43-4407

### VENTURIS FOR 40MM & 44MM

EMPI now offers you the opportunity to fully tune your carburetor for your particular application. For reference EMPI 40mm Brosol / Solex come standard with 28mm venturis and 44mm versions come with 30mm venturis as standard.

43-4407 28mm Venturi for EMPI 40mm & 44mm, Pair

43-4408 30mm Venturi for EMPI 40mm & 44mm, Pair

43-4409 32mm Venturi for EMPI 40mm & 44mm, Pair



43-5023

### NEEDLE & SEAT FOR BROSOL CARBURETORS

43-5021 Needle & Seat, 1.50mm, Brosol, Each

43-5022 Needle & Seat, 1.75mm, Brosol, Each

43-5023 Needle & Seat, 2.00mm, Brosol, Each

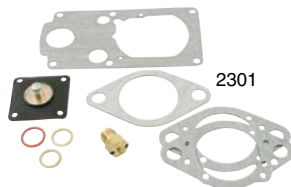

2301

### CARBURETOR REBUILD KITS

These rebuild kits cover all models of the Kadron / Brosol / Solex 40/44 carburetors. Kits come complete with accelerator pump diaphragm, needle/seat and all necessary o-rings and gaskets.

2301 Carb. Rebuild Kit, Boxed

9937 Carb. Rebuild Kit, Skinpacked



43-6191

43-4415

### EMPI / BROSOL / SOLEX VELOCITY STACKS

Universal slip in fit allows these spun aluminum velocity stacks to work for both the 40mm and 44mm models of the EMPI / Brosol / Solex carburetor. (Non-electric choke versions only).

43-4415 EMPI / Brosol / Solex Velocity Stacks, Pair

43-6191 Large Pre Filter Bootie. 5" Dia,

Fits 3 1/2" - 5" Velocity Stacks.

Water repellent, breathable top, Denier cylinder with elastic. Black, Pair, No Logo



# INTAKE - CARB. KITS & COMPONENTS

## REPLACEMENT COMPONENTS FOR TYPE 1 & TYPE 2 EMPI BROSOL / SOLEX KITS

### BRASS FUEL FITTING

This is the same 1/4" brass tee as used in our EMPI Brosol / Solex kits. We also offer a 5/16" version for high flow use.

- 43-4402                    1/4" Brass Fuel Fitting "T", Each
- 43-5203                    5/16" Brass Fuel Fitting "T", Each



43-4402

### CARB. BASE THROTTLE ASSEMBLY

Repair old worn out throttle shafts the right way, replace the assembly! Brand new assemblies will fix your "leakage" problems. (For 40mm non-electric choke models only).

- 43-4405                    Repl. Carb. Base Throttle Assembly, Each



43-4405

## REPLACEMENT JETS

### EMPI STOCK REPLACEMENT CARBURETORS, SOLEX & BROSOL / SOLEX CARBURETORS

#### EMPI STOCK REPLACEMENT CARBURETORS, SOLEX AND BROSOL / SOLEX JETS

Replacement Main and Idle Jets for EMPI and Solex-Style replacement carburetors and Solex/Brosol carburetors. Sold as Individual Jets or in a Jet Assortment Kit. The kit features a see-through EMPI box with compartments for each Jet Size and a Legend on the inside cover.

Each kit comes with...

- 10 pieces each of Main Jets from 112.5 to 140 in 2.5 increments
- 5 pieces each Main Jets from 145 to 170 in 5.0 increments
- 10 pieces Idle Jets from 45 to 70 in 5.0 increments

Jets Fit 98-1225-B, 98-1287-B, 98-1288-B, 98-1289-B, 98-1292-B plus 40 & 44 Brosol/Solex Carburetors.

- 43-5001                    EMPI Stock Replacement Carburetors, Solex, Brosol/Solex Jet Assortment Kit

Individual Jets			
Jets = 1 piece			
Main Jets		Idle Jets	
EMPI, Solex, Solex/Brosol			
Size	P/N	Size	P/N
112.5	43-5112-7	.45	43-5045-7
115	43-5115-7	.50	43-5050-7
117.5	43-5117-7	.55	43-5055-7
120	43-5120-7	.60	43-5060-7
122.5	43-5122-7	.65	43-5065-7
125	43-5125-7	.70	43-5070-7
127.5	43-5127-7		
130	43-5130-7		
132.5	43-5132-7		
135	43-5135-7		
137.5	43-5137-7		
140	43-5140-7		
145	43-5145-7		
150	43-5150-7		
155	43-5155-7		
160	43-5160-7		
165	43-5165-7		
170	43-5170-7		





## BILLET HPMX/IDF AIR CLEANERS

### WITH 3 1/2" ELEMENT

- 7" x 4 1/2" x 3 1/2" Washable Gauze Element
- Stainless Steel Mounting Hardware
- Precision Machined Channel for Element (Eliminates dirt blow-by)
- 6061-T6 Aluminum Top and Bottom
- Milled EMPI Logo and Accent Lines
- Fully Polished Top
- Same unit as supplied in EMPI Deluxe HPMX/IDF Carb. Kits!

**43-6015** Fits All 40 thru 48 EMPI HPMX, WEBER IDF and Dellorto DRLA, Each

**8734** Gauze Element Only, Oval 3 1/2"

### WITH 6" ELEMENT

- 7" x 4 1/2" x 6"
- Same specs as above except 6" height of Air Cleaner

**43-6016** Fits All 40 thru 48 EMPI HPMX, WEBER IDF and Dellorto DRLA, Each

**43-6011** Gauze Element Only, Oval 6"

43-6015 (Components)



3 1/2" Element



43-6015 (Assembled)



Milled EMPI Logo

Machined Channel for Element



43-6016

## EMPI "KING KONG" HPMX & IDF AIR CLEANERS

These air cleaner assemblies feature the finest components in the industry. They have heavy duty chrome tops and bottoms and come with high flow washable gauze filter elements. P/N: 43-6006 has high tension springs for extra rigidity and twist resistance. For use on EMPI HPMX, WEBER IDF and Dellorto DRLA.

- 43-6006** Oval Air Cleaner, 9" x 5 1/2" x 6" High, Each
- 43-6007** Oval Replacement Element, 6" High, Each
- 43-6010** Oval Air Cleaner, 7" x 4 1/2" x 6" High, Each
- 43-6011** Oval Replacement Element, 6" High, Each

## EMPI IDA AIR CLEANERS

With the same construction features as our "King Kong" IDF Air Cleaners; including High-Tension Retaining Springs like P/N: 43-6006 on the 6" high unit only. With the deep drawn Heavy Duty Steel Base custom made for the [WEBER 48 IDA](#), and also works with EMPI [EPC 48 and 51 Carbs](#). Includes gasket and special velocity stack spacers on 6" high unit only. **(Will not work with pro velocity stacks).**

- 43-6012** Oval Air Cleaner, 9" x 5 1/2" x 6" High, Each (Will not fit on VW sedans)
- 43-6007** Oval Replacement Element, 6" High, Each
- 43-6013** **NEW!** Oval Air Cleaner, 9" x 5 1/2" x 3 1/2" High, Each (Fits under decklid on Type 1)
- 43-6008** **NEW!** Oval Replacement Element, 3 1/2" High, Each





# INTAKE - AIR CLEANERS & PRE-FILTERS

## CHROME AIR CLEANERS

Featuring Show Quality heavy duty Chrome-plated steel, these Air Cleaners are offered in 7" x 4 1/2" Oval and 6 3/4" x 4 1/2" Rectangular Styles with Washable Gauze elements and include hardware and gaskets.

### OVAL AIR CLEANERS

- 8714                      WEBER 40-48 IDF & Dellorto DRLA, EMPI HPMX, 3 1/2" High w/Gauze (1-Hole Top)
- 8722                      WEBER 38-45 DCOE & Dellorto DHLA, 1 3/4" High w/Gauze (2-Hole Top)
- 8737                      WEBER 38-45 DCOE & Dellorto DHLA, 3 1/2" High w/Gauze (1-Hole Top)
- 8726                      WEBER 40-42 DCNF, 1 3/4" High w/Gauze (2-Hole Top)



8714

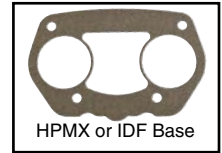

8722

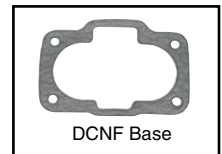
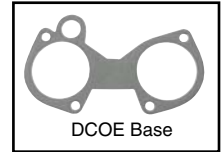

### OVAL REPLACEMENT ELEMENTS

- 8736                      Oval Gauze, 7" x 4 1/2" x 1 3/4" High
- 8734                      Oval Gauze, 7" x 4 1/2" x 3 1/2" High
- 43-6011                  Oval Gauze, 7" x 4 1/2" x 6" High, Each
- 43-6007                  Oval Gauze, 9" x 5 1/2" x 6" High, Each



### RECTANGULAR AIR CLEANERS

- 8805                      WEBER 40-48 IDF & Dellorto DRLA, EMPI HPMX, 1 3/4" High w/Gauze
- 9024                      WEBER 40-48 IDF & Dellorto DRLA, EMPI HPMX, 2 1/2" High w/Gauze
- 9026                      WEBER 40-48 IDF & Dellorto DRLA, EMPI HPMX, 1 5/8" High w/Gauze (Type 3 Application)  
Replacement Element P/N: 9034
- 8806                      WEBER DGV, DGAV, DGEV, 1 3/4" High w/Gauze
- 9025                      WEBER DGV, DGAV, DGEV, 2 1/2" High w/Gauze
- 8809                      WEBER DFV, DFAV, DFEV, 1 3/4" High w/Gauze
- 9032                      WEBER DFV, DFAV, DFEV, 2 1/2" High w/Gauze
- 17-2823                  Stock VW Carb, Clamp-on 2" High w/Gauze, Includes Clamp  
Replacement Element P/N: 9033



8805



9032



8806



17-2823  
(Stock VW)



9025



### RECTANGULAR REPLACEMENT ELEMENTS & CLIPS

- 9033                      Rectangular Gauze, 6 3/4" x 4 1/2" x 1 3/4" High
- 9034                      Rectangular Gauze, 6 3/4" x 4 1/2" x 1 1/2" High (For P/N 9026 Only)
- 9029                      Rectangular Gauze, 6 3/4" x 4 1/2" x 2 1/2" High
- 8685                      Replacement Clips, 2 1/2", Pack of 6
- 8686                      Replacement Clips, 1 3/4", Pack of 6
- 9589                      Bulk Replacement Clip, 2 1/2", Each
- 9590                      Bulk Replacement Clip, 1 3/4", Each





## ROUND CHROME AIR CLEANERS

These Air Cleaners are available in High, Low and Super-Low Profiles with your choice of Paper, Washable Gauze or easy to clean Foam Elements and feature High Quality Chrome. All feature breather connection.

(Note: Air Cleaner measurements are Overall Height, Base to Top. Replacement Elements are Height of Element)



9076



9081



8957



9006



8970



8975

### 6 3/8" DIAMETER LOW PROFILE

9076 Air Cleaner for Stock VW Carb., 2 1/4" High w/Paper

9081 Replacement Element, 1 7/16" High, Paper

8957 Air Cleaner for Stock VW Carb., 2 1/2" High w/Gauze

9006 Replacement Element, 1 3/4" High, Gauze

### 6 3/8" DIAMETER - HIGH-PROFILE

8970 Air Cleaner for Stock VW Carb., 3 1/2" High w/Gauze

8975 Replacement Element, 2 1/2" High, Gauze

## RUBBER FLANGE GAUZE AIR CLEANERS

It is a washable and reusable unit with Steel top, Gauze Filter and rubber base. They add style and performance and fits most upright applications. Constructed with a super strong molded pliable rubber flange which absorbs vibration, they are available in Oval and Round styles. Neck can be stretched up to 1/16" for added applications. Use with or without 90° Nylon Vent tube (included). Comes with clamp.



17-2976



17-2976 Oval Gauze Rubber Flange Air Cleaner for Stock VW Carb., 2" Neck, 4 7/16" x 6 7/8" x 2 3/4" High



17-2978



17-2978 Round Gauze Rubber Flange Air Cleaner for Stock VW Carb., 2" Neck, 5 1/4" Dia. x 2 3/4" High

## LOW PROFILE CHROME AIR CLEANER



17-2981

**NEW!**



17-2981 **NEW!** Air Cleaner for EMPI 38EGAS, Weber DGV, DGAV and DGEV carburetors. 1 3/4" High Gauze Filter Element. (Replacement Air Cleaner for 47-0628, 47-0640 & 47-0645 Kits)



# INTAKE - AIR CLEANERS & PRE-FILTERS

## ROUND CHROME AIR CLEANERS

### 5 1/2" DIAMETER - HIGH FLOW

- 9183 Air Cleaner for Stock VW Carb., 2 1/2" High w/Paper
- 9184 Air Cleaner for 2 5/8" Neck, 2 1/4" High w/Paper
- 9185 Replacement Element, 1 1/2" High, Paper



- 9044 Air Cleaner for Stock VW Carb., 3" High w/Gauze
- 9048 Replacement Element, 2" High, Gauze



- 9045 Air Cleaner for Stock VW Carb., 4" High w/Gauze
- 9047 Air Cleaner for 2 5/8" Neck, 3 3/4" High w/Gauze
- 9049 Replacement Element, 3 1/8" High, Gauze



- 9121 Air Cleaner for Stock VW Carb., 2 3/4" High w/Foam
- 9133 Replacement Element, 2" High, Foam w/Mesh (Pictured Below)



- 9123 Air Cleaner for Stock VW Carb., 3 3/4" High w/Paper
- 9145 Replacement Element, 3" High, Paper



## CHROME LOUVERED AIR CLEANERS

Show quality Chrome Louvered Dome-Style Air Cleaners all are 5 1/2" diameter.

- 8674 Air Cleaner for Stock VW Carb., 3" High, Foam W/ Mesh
- 9133 Replacement Element, 2" High, Foam w/Mesh
- 9048 Replacement Element, 2" High, Gauze



## CHROME MINI AIR CLEANER

Small 4" Diameter Chrome Air Cleaner with Paper element.

- 9012 Air Cleaner for Stock VW Carb., 3" High w/Paper
- 9013 Air Cleaner for 2 5/8" Neck, 3" High w/Paper
- 9014 Replacement Element, 2" High, Paper



## STOCK VW AIR CLEANER

- 17-2823 Stock VW Carb, Clamp-on, 2" High w/Gauze, Includes Clamp
- Replacement Element P/N: 9033





## OFF-ROAD AIR CLEANERS

Designed for Off-Road Competition, these air cleaners feature a large 10" diameter Spun Aluminum Cover and come with Gauze Element. Use with P/N: 9154 & 9156 Mount Kits.



- 9000** Air Cleaner for Stock VW Carb., 5 1/4" High w/Gauze (Boxed)
- 9001** Air Cleaner for 2 5/8" Neck, 5 1/4" High w/Gauze (Boxed)

**9176** Replacement Element, 3 1/4" High, Gauze

- 9154** Off-Road Air Cleaner Mount w/Clamps, for 2 5/8"
- 9156** Off-Road Air Cleaner Mount w/Clamps, 2" Neck, for Stock VW Carb.

9176 (Gauze)

9154

## POD-STYLE GAUZE AIR CLEANER

Featuring a Washable Chrome top Gauze Filter, these Air Cleaners fit most up-right applications.



9002

- 9002** Pod-Style Air Cleaner for Stock VW Carb. and EPC 34, 2" Neck, 4 3/4" High
- 9004** Pod-Style Air Cleaner for 2 5/8" Neck, 4 3/4" High

## TYPE 3 CHROME AIR CLEANERS

Super-Low profile fits under engine cover without cutting. Features Foam Element.



- 9127** Type 3 Air Cleaner Kit, Pair
- 9155** Replacement Element, Foam, Each

## TYPE 3 & 4 EPC 34/ICT 34 AIR CLEANER

Same 1 Pc. Gauze Element Assembly as provided in our EMPI Dual EPC 34 & 34 ICT kits for Type 3 and Type 4 pancake engines.



- 9128** Air Cleaner for Type 3 & 4 w/EPC 34 & 34 ICT WEBER Carbs, 2" Neck, Each





# INTAKE - AIR CLEANERS & PRE-FILTERS

## RUBBER FLANGE GAUZE AIR CLEANERS

It is a washable and reusable unit with Chrome top, Gauze Filter and rubber base. They add style and performance and fits most upright applications. Constructed with a super strong molded pliable rubber flange which absorbs vibration, they are available in Oval and Round styles. Neck can be stretched up to 1/16" for added applications. Use with or without 90° Nylon Vent tube (included). Comes with clamp.

- 17-2976 Oval Gauze Rubber Flange Air Cleaner for Stock VW Carb., 2" Neck, 4 7/16" x 6 7/8" x 2 3/4" High
- 17-2978 Round Gauze Rubber Flange Air Cleaner for Stock VW Carb., 2" Neck, 5 1/4" Dia. x 2 3/4" High



## PROGRESSIVE CARBURETOR AIR CLEANER ADAPTER

This adapter allows installation of our 9001 Spun Aluminum Off-Road Air Cleaner, or any 2 5/8" air cleaner to your EMPI EPC 32/36, Weber or Holley Progressive carburetor, allowing clearance between A/C and carb. Includes gasket and mounting hardware.

- 9189 Progressive Carburetor Air Cleaner Adapter



## CARBURETOR SPACER FOR EPC/DFV/DGV

This die-cast aluminum plenum-style Spacer will add 5.5mm between your carb and manifold to help solve clearance issues for larger Alternators and/or other issues. Use with all EPC, DFV and DGV progressive and synchronous carburetors. Comes with 2 Plenum-cut Gaskets for installation.

- 17-2980 Carburetor Spacer for EPC/DFV/DGV, 5.5mm, Set w/Gaskets

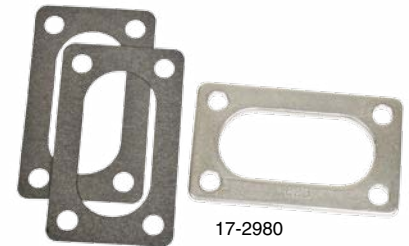

## ALUMINUM AIR FILTERS

This design is used by almost every off road race car racing today. Available with 4" inlets and 4" outlets in either 12" or 15" length housings. This aluminum air filter uses a 2 phase inner filtering system. Choose from right or left side in the 4" X 4" models in both 12" and 15" bodies.

- 17-2516 Air Filter, Polished Aluminum, 12" Body, 4" Inlet, 4" Outlet Left Side, Each (Boxed)
- 17-2517 Air Filter, Polished Aluminum, 12" Body, 4" Inlet, 4" Outlet Right Side, Each (Boxed)
- 17-2519 Air Filter, Polished Aluminum, 15" Body, 4" Inlet, 4" Outlet Left Side, Each (Boxed)
- 17-2520 Air Filter, Polished Aluminum, 15" Body, 4" Inlet, 4" Outlet Right Side, Each (Boxed)

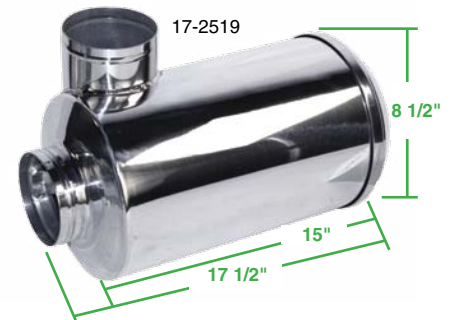

## SLOTTED AIR FILTER

The same concept as our other Air Filters, but with a slotted non-directional inlet. Available in 12" and 15" bodies. 4" outlet only. **Supplied without filter element.**

- 17-2521 Slotted Air Filter, Polished Aluminum, 12" Body Each (Boxed)
- 17-2522 Slotted Air Filter, Polished Aluminum, 15" Body Each (Boxed)

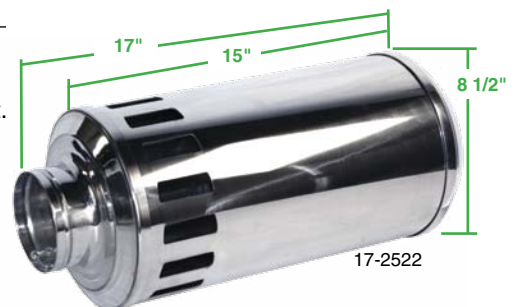



## EMPI PRE-FILTERS

EMPI Pre-Filters feature a patented "Micro Mesh" Nylon filtration system that stops sand and dirt before it gets to your air cleaner element. Elastic base stretches over your air cleaner for a snug fit with no air restriction to speak of. It installs with virtually no carb. adjustment. Available in different colors with EMPI logo to match your color scheme.



43-6191

43-6190

(W x L x H)

- 43-6190** Pre Filter, 3 1/2" Dia, Black, No Logo, Pr.
- 43-6191** Pre Filter, 5" Dia, Black, No Logo, Pr.

- 43-6101** Oval, 4 1/2" x 7" x 3 1/2", Blue
- 43-6102** Oval, 4 1/2" x 7" x 3 1/2", Red
- 43-6103** Oval, 4 1/2" x 7" x 3 1/2", Black

- 43-6111** Oval, 4 1/2" x 7" x 6", Blue
- 43-6112** Oval, 4 1/2" x 7" x 6", Red
- 43-6113** Oval, 4 1/2" x 7" x 6", Black

- 43-6120** Oval, 5 1/2" x 9" x 3 1/2", Yellow
- 43-6121** Oval, 5 1/2" x 9" x 3 1/2", Blue
- 43-6122** Oval, 5 1/2" x 9" x 3 1/2", Red
- 43-6123** Oval, 5 1/2" x 9" x 3 1/2", Black
- 43-6124** Oval, 5 1/2" x 9" x 3 1/2", Purple

- 43-6131** Oval, 5 1/2" x 9" x 6", Blue
- 43-6132** Oval, 5 1/2" x 9" x 6", Red
- 43-6133** Oval, 5 1/2" x 9" x 6", Black

- 43-6141** For EMPI 40mm Solex/Brosol, Blue
- 43-6142** For EMPI 40mm Solex/Brosol, Red
- 43-6143** For EMPI 40mm Solex/Brosol, Black
- 43-6144** For EMPI 40mm Solex/Brosol, Purple

- 43-6163** For Rectangular 2 1/2" High Filters, Black
- 43-6173** For P/N: 9002/9004 Pod Style Filters, Black
- 43-6181** For P/N: 16-2049/16-2050 Breather, Blue
- 43-6182** For P/N: 16-2049/16-2050 Breather, Red
- 43-6183** For P/N: 16-2049/16-2050 Breather, Black



43-6181



43-6173



43-6163

## FOAM FILTER COVERS (GREY)

Foam Air Cleaner Covers with EMPI logo have been race and sand proven for years. Oil them down or run them dry...they protect your air cleaner elements from the "Big Chunks". Foam is grey in color with EMPI screened in white.



(W x L x H)

- 43-6233** Oval, 4 1/2" x 7" x 3 1/2" High Element

## CLEANER FOR GAUZE ELEMENTS

Clean your Gauze Elements quickly and easily.



9039

- 9039** Air Filter Cleaner, Bottle (Can Not Be Shipped Via Air)



# INTAKE - ACCESSORIES, JETS & MISC.

## EMPI VELOCITY STACKS FOR 48 IDA / EPC 48 / EPC 51

EMPI's spun aluminum pro stacks use a race proven design to maximize airflow and velocity. Designed to mount just like the originals with no modifications of the carburetor required. Pro Velocity Stacks are not compatible with EMPI King Kong air cleaners.

- 43-6057 EMPI Aluminum Pro Velocity Stacks, 3 1/2" H x 3 7/8" W on Top, Pair
- 43-6052 EMPI Aluminum Replacement Velocity Stacks, 2 7/8" H x 2 3/4" W on Top, Pair
- 43-6191 Large Pre Filter Bootie, 5" Dia, Fits 3 1/2" - 5" Velocity Stacks. Pair, Black, No Logo



## EMPI CHROME VELOCITY STACKS

These Chrome Stacks or "Air Horns" aid in prevention of fuel stand-off and look great. Fits all EMPI HPMX, IDF WEBER and DRLA Dellorto carbs. Three sizes are available to aid in matching to proper air cleaner applications. All Stacks are Steel with Chrome finish.

- 43-6050 2 1/4" Chrome Velocity Stacks, Pair
- 43-6054 4" Chrome Velocity Stacks, Pair
- 43-6056 6" Chrome Velocity Stacks, Pair
- 43-6190 Small Pre Filter Bootie, 3 1/2" Dia, Fits up to 3 1/2" Velocity Stacks. Pair, Black, No Logo

## VELOCITY STACK COVERS

High quality molded red vinyl caps snap over carburetor velocity stacks to protect from unwanted debris or water entering the carburetor when the vehicle is not being operated.

- 43-5720 Velocity Stack Covers, for IDF & HPMX Carb., Pair (Fits WEBER & EMPI Stacks), I.D. is 2.500"
- 43-5721 Velocity Stack Covers, for 48 IDA / EPC 48 & EPC 51 Carbs., Pair (Fits WEBER Stacks & EMPI Stacks, P/N 43-6052) I.D. is 2.75"
- 43-5722 Velocity Stack Covers, for 48 IDA / EPC 48 & EPC 51 Carbs., Pair (Fits EMPI Pro Velocity Stacks) I.D. is 3.850"



## COIL RELOCATION KIT

Relocating the coil from the fan housing is necessary when you install dual carburetors on up-right engines. This engineered kit allows you to tuck the coil neatly out of the way, without modification. Complete with zinc plated bracket and mounting hardware. This kit is normally included in all Type 1 EMPI hex bar carb. kits & linkage kits.

- 43-5204 Coil Relocation Kit



## CARBURETOR SYNCHRONIZERS

Proper synchronization of dual carburetor set-ups is essential for peak performance. Accurately dial in your carbs. with one of these Carburetor Synchronizers. Our P/N: 5746 is the original, SU type, bubble gauge with pivoting gauge tube for down-draft or side-draft applications. P/N: 43-5712 includes two Adapters which allows for 1-tool usage on a wide spectrum of applications. The Pro-Synchronizer will not restrict airflow and features an easy to read 1-30 kg/h numbered scale for precise synchronization.

- 43-5712 EMPI Universal Pro-Sync, w/2 Adapters
- 5746 SU Type Carburetor Synchronizer



## CARBURETOR SYNCHRONIZER URETHANE ADAPTERS

Dialing in your Dual EPC34s, Weber ICTs and Solex/Brosol just got a bit easier! These urethane adapters are made specifically for these carburetors. With easy push-on fit, they are impervious to gas and oil. Even the Solex/Brosol Adapter fits without removing the air cleaner center stud. For use with P/N 43-5712 EMPI Universal Pro-Sync.

- 43-5713 Synchronizer Adapter 34EPC/34ICT Carburetors, Each
- 43-5714 Synchronizer Adapter Solex/Brosol Carburetors, Each

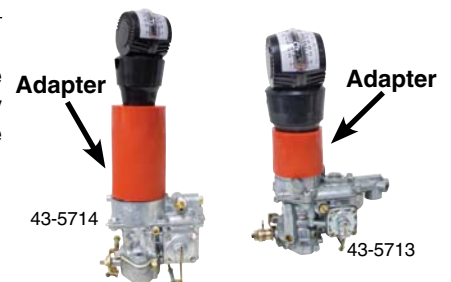

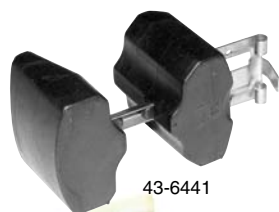

43-6441

## CARBURETOR FLOATS

Same floats as supplied in EMPI's carburetors. These new upgraded plastic versions will also fit WEBER carburetors.

- 43-6441 Replacement Float for EMPI 40/44 HPMX or 40/44/48 IDF, Each
- 43-6550 Replacement Float for EMPI EPC 32/36A, E, M, EPC 38, Each
- 43-6820 Replacement Float for EMPI EPC 34 or 34 ICT, Each



43-5715

## CARBURETOR TOOLS

These precision tools allow you to fine-tune your carburetors. The Jet Reamer Set features precision tapered reamers that cut to close tolerances. A selection of tapered reamers is packed in a protective plastic case. Know exactly what size you have cut your jets to with our Jet Size Gauges. Two size range gauges are available to fit all applications.

- 43-5715 Jet Reamer Kit
- 43-5716 Jet Gauge, .45mm - 1.50mm Range
- 43-5717 Jet Gauge, 1.50mm - 3.00mm Range



43-5717

43-5716

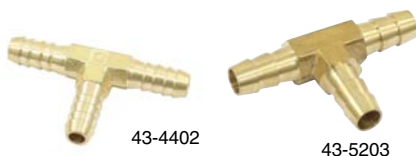

43-4402

43-5203

## BRASS FUEL TEE'S

A must have for all dual carburetor applications. If you are using a plastic tee, now is the time to upgrade. All EMPI Dual Carb. Kits come with Brass Fuel Tee's.

- 43-5203 5/16" Barbed Brass Fuel Tee
- 43-4402 1/4" Barbed Brass Fuel Tee



43-5709

## HPMX OR IDF FUEL ENRICHMENT BLOCK-OFF PLATE

Use this chrome plated blockoff plate when you remove the "stock" choke assembly from IDF carburetors. Supplied with screws and washers.

- 43-5709 HPMX or IDF Fuel Enrichment Block-Off Plate



3447

17-2824

## HEAT RISER BLOCK-OFF PLATES

Covers heat riser flanges when intake heat riser is not used. A must when installing most dual carb kits. Includes gaskets.

- 3447 Heat Riser Block-Off Plate Kit
- 17-2824 Chrome Heat Riser Block-Off Plate Kit



## UNI-LINK KIT

Allows you to adapt your linkage to fit any EPC 32/36F, DFV/DFEV Progressive Carb.

- 43-0602 Uni-Link Kit



## EXTRA CLEARANCE NUTS

8mm 1.25 - thread with 11mm outside diameter nuts may be used on intake and exhaust for extra clearance. Made from Brass to resist rust and avoid seized threads.

- 43-6051 Brass 8mm-1.25 thread, 11mm Head, Int./Exh. Nuts, Set of 8
- 43-6051-B Bulk Brass 8mm-1.25 thread, 11mm Head, Int./Exh. Nuts, Bag of 100



# INTAKE - ACCESSORIES, JETS & MISC.

EMPI maintains a huge inventory of Replacement Parts and Jets for EMPI/WEBER/Solex Carburetors. For fine tuning of any carburetor listed below, just look up the series of your carburetor and which jet style you need, then match the size of the jet to the EMPI part number listed. All Metering Components listed are sold as "Each's". All component parts are of EMPI's own brand unless specified. (Series are used as reference only).

## IDLE JETS FOR THE FOLLOWING CARBS:



**74405.XXX SERIES**



**74409.XXX SERIES**



**74403.XXX SERIES**



**74821.XXX SERIES**



**74822.XXX SERIES**



**74823.XXX SERIES**

40/44 HPMX, 40/44/48 IDF, DCFN		EPC 34, 34 ICT, EPC 32/36 (Primary), 32/36 DGV (Primary), EPC 38E (Primary), 38 DGS (Primary)		EPC 32/36, 32/36 DGV, EPC 32/36F, 32/36 DFV, EPC 38E, 38 DGS		DCOE F8		DCOE F9		EPC 48/51, 48 IDA	
SIZE	P/N	SIZE	P/N	SIZE	P/N	SIZE	P/N	SIZE	P/N	SIZE	P/N
.40	43-5510	.40	43-5519	.40	43-5501	.40	43-5524	.40	43-5530	.40	43-5536
.45	43-5511	.45	43-5520	.45	43-5502	.45	43-5525	.45	43-5531	.45	43-5537
.47	43-5512	.50	43-5521	.50	43-5503	.50	43-5526	.50	43-5532	.50	43-5538
.50	43-5513	.55	43-5522	.55	43-5504	.55	43-5527	.55	43-5533	.55	43-5539
.52	43-5514	.60	43-5523	.60	43-5505	.60	43-5528	.60	43-5534	.60	43-5540
.55	43-5546	.65	43-5547	.65	43-5506	.65	43-5529	.65	43-5535	.65	43-5541
.57	43-5515	.70	43-5548	.70	43-5507					.70	43-5542
.60	43-5516	.75	43-5549	.75	43-5508					.75	43-5543
.65	43-5517										
.70	43-5518										

## MAIN JETS FOR THE FOLLOWING CARBS:



**73401.XXX SERIES**



**73801.XXX SERIES**

40/44 HPMX, 40/44/48 IDF, EPC 48/51, 48 IDA, DCO / DCOE		EPC 32/36, 32/36 DGV, EPC 32/36F, 32/36 DFV, EPC 38E, 38 DGS, EPC 34, 34 ICT	
SIZE	P/N	SIZE	P/N
1.10	43-5301	1.10	43-5322
1.15	43-5302	1.15	43-5323
1.20	43-5303	1.20	43-5324
1.25	43-5304	1.25	43-5325
1.30	43-5305	1.30	43-5326
1.35	43-5306	1.35	43-5327
1.40	43-5307	1.40	43-5328
1.45	43-5308	1.45	43-5329
1.50	43-5309	1.50	43-5330
1.55	43-5310	1.55	43-5331
1.60	43-5311	1.60	43-5332
1.65	43-5312	1.65	43-5333
1.70	43-5313	1.70	43-5334
1.75	43-5314	1.75	43-5335
1.80	43-5315	1.80	43-5336
1.85	43-5316	1.85	43-5337
1.90	43-5317	1.90	43-5338
1.95	43-5318	1.95	43-5339
2.00	43-5319	2.00	43-5340
2.05	43-5320	2.05	43-5341
2.10	43-5321	2.10	43-5342

## AIR JETS FOR THE FOLLOWING CARBS:



**77401.XXX SERIES**



**77201.XXX SERIES**

40/44 HPMX, 40/44/48 IDF, EPC 48/51, 48 IDA, DCOE		EPC 32/36, 32/36 DGV, EPC 32/36F, 32/36 DFV, EPC 38E, 38 DGS, EPC 34, 34 ICT	
SIZE	P/N	SIZE	P/N
1.00	43-5401	1.05	43-5426
1.05	43-5402	1.10	43-5427
1.10	43-5403	1.15	43-5428
1.15	43-5404	1.20	43-5429
1.20	43-5405	1.25	43-5430
1.25	43-5406	1.30	43-5431
1.30	43-5407	1.35	43-5432
1.35	43-5408	1.40	43-5433
1.40	43-5409	1.45	43-5434
1.45	43-5410	1.50	43-5435
1.50	43-5411	1.55	43-5436
1.55	43-5412	1.60	43-5437
1.60	43-5413	1.65	43-5438
1.65	43-5414	1.70	43-5439
1.70	43-5415	1.75	43-5440
1.75	43-5416	1.80	43-5441
1.80	43-5417	1.85	43-5442
1.85	43-5418	1.90	43-5443
1.90	43-5419	2.00	43-5444
1.95	43-5420		
2.00	43-5421		
2.05	43-5422		
2.10	43-5423		
2.15	43-5424		
2.20	43-5425		

# INTAKE - ACCESSORIES, JETS & MISC.



All component parts are of EMPI's own brand unless specified. (Series are used as reference only).

## PUMP EXHAUST VALVES FOR THE FOLLOWING CARBS:



**79701.XXX SERIES**

40/44 HPMX, 40/44/48 IDF,  
EPC 48/51, 48 IDA,  
DCO/DCOE

SIZE	P/N
0.000	43-5650
0.350	43-5651
0.500	43-5652
0.550	43-6400

## EMULSION TUBES FOR THE FOLLOWING CARBS:



**61450.XXX SERIES**

40/44 HPMX, 40/44/48 IDF,  
EPC 48/51, 48 IDA,  
DCO/DCOE

SIZE	P/N
F2	43-5670
F3	43-5671
F4	43-5672
F5	43-5673
F7	43-5674
F8	43-5675
F9	43-5676
F10	43-5677
F11	43-5678
F14	43-5679
F15	43-5680
F16	43-5681



**61440.XXX SERIES**

EPC 32/36, 32/36 DGV,  
EPC 32/36F, 32/36 DFV,  
EPC 34, 34 ICT,  
EPC 38E, 38 DGS

SIZE	P/N
F6	43-5682
F24	43-5683
F50	43-5684
F66	43-5685

## AUXILLARY VENTURIS FOR THE FOLLOWING CARBS:



**71111.350 SERIES**

EPC 32/36, 32/36 DGV

SIZE	P/N
3.5mm	43-5687

## MAIN VENTURI'S FOR THE FOLLOWING CARBS:



**72302.XXX SERIES**



**71506.XXX SERIES**



**71507.XXX SERIES**



**72116.XXX SERIES**



**72128.XXX SERIES**



**72136.XXX SERIES**

40DCOE		40 IDF		40/44 HPMX, 44 IDF		45DCOE		EPC 48/51, 48IDA		48, 50, 55DCO	
SIZE	P/N	SIZE	P/N	SIZE	P/N	SIZE	P/N	SIZE	P/N	SIZE	P/N
28mm	43-5601	28mm	43-5606	28mm	43-5625	30mm	43-5612	40mm	43-5618	42mm	43-5620
30mm	43-5602	30mm	43-5607	30mm	43-5626	32mm	43-5613	42mm	43-5619		
32mm	43-5603	32mm	43-5608	32mm	43-5609	34mm	43-5614				
34mm	43-5604			34mm	43-5610	36mm	43-5615				
36mm	43-5605			36mm	43-5611	38mm	43-5616				
						40mm	43-5617				

## ACCELERATOR PUMP JETS FOR THE FOLLOWING CARBS:



**76801.XXX SERIES**



**76210.XXX SERIES**



**76215.XXX SERIES**



DCOE		40/44 HPMX, 40/44/48 IDF		EPC 32/36, 32/36 DGV (Double Squirter)		EPC 32/36, 32/36 DGV (Single Squirter)	
SIZE	P/N	SIZE	P/N	SIZE	P/N	SIZE	P/N
0.35	43-5380	0.40	43-5388	0.40	43-5391	0.50	43-5398
0.40	43-5381	0.50	43-5389	0.45	43-5392		
0.45	43-5382	0.55	43-5390	0.50	43-5393		
0.60	43-5384			0.55	43-5394		
0.65	43-5385			0.60	43-5395		
0.70	43-5386			0.65	43-5396		
				0.70	43-5397		



# INTAKE - ACCESSORIES, JETS & MISC.

All component parts are of EMPI's own brand unless specified. (Series are used as reference only).

## NEEDLE VALVE FOR THE FOLLOWING CARBS:



79503.XXX SERIES



76511.XXX SERIES



79518.XXX SERIES



79519.XXX SERIES

DCN, DCNF, DCOE

40/44 HPMX,  
40/44/48 IDF

EPC 38E, 38 DGS

EPC 32/36, 32/36 DGV,  
EPC 32/36F, 32/36 DFV

SIZE	P/N	SIZE	P/N	SIZE	P/N	SIZE	P/N
1.50mm	43-5360	1.50mm	43-5366	2.00mm	43-5369	1.50mm	43-5371
1.75mm	43-5361	1.75mm	43-5367			1.75mm	43-5372
2.00mm	43-5362	2.00mm	43-5368			2.00mm	43-5373
2.25mm	43-5363					2.50mm	43-5374
2.50mm	43-5364						
3.00mm	43-5365						

## MISC. PARTS



43-0620

EPC 32/36F, 32/36 DFV

DESCRIPTION	P/N
Electric Choke Element	43-0620

## MISC. PARTS

40/44 HPMX, 40/44/48 IDF (All Sold Each)



43-6410



43-6413



43-6414



43-6417



43-6422



43-6440



43-6423



43-6424



43-6552

DESCRIPTION	P/N
Pump Jet Washer	43-6410
Throttle Shaft Nut, 7mm Thread, 11mm Hex	43-6413
Throttle Shaft Lock Tab Washer	43-6414
Idle Jet O-Ring	43-6417
Cupwasher for O-Ring	43-6422
Spring for Mixture Screw	43-6423
Mixture Screw	43-6424
Extended Jet Holder for Emulsion Tubes	43-6440
Plug and Washer	43-6552

## MISC. PARTS



43-5350



43-5351

EPC 32/36, 32/36 DGV, EPC 38E, 38 DGS

DESCRIPTION	P/N
Idle Cut-Off Solenoid	43-5350
Electric Choke Element	43-5351

NOTE FOR 43-5350

Some Carburetors may require  
clearancing to fit

## MISC. PARTS

EPC 48/51 & 48 IDA CARBS

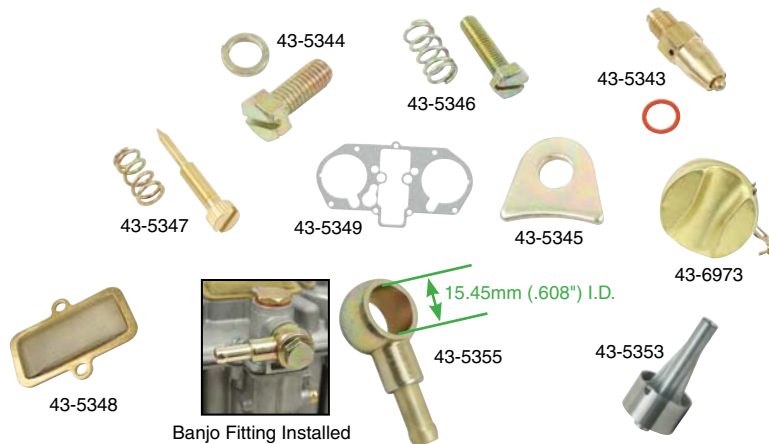

Banjo Fitting Installed

DESCRIPTION	P/N
3.0 Needle and Seat (To Replace 2.0)	43-5343
Stack Hold Down Screw and Washer	43-5344
Stack Hold Down Tab	43-5345
Fast Idle Screw and Spring	43-5346
Air Fuel Mixture Screw and Spring	43-5347
Main Jet Screen	43-5348
Top Gasket	43-5349
Auxiliary Venturi	43-5353
Banjo Fitting w/ Press In 1/4" Barb	43-5355
Brass Float Only	43-6973

# INTAKE - CARBURETOR SCHEMATICS



EPC 48 / EPC 51

47-1048-0 / 47-1050-0

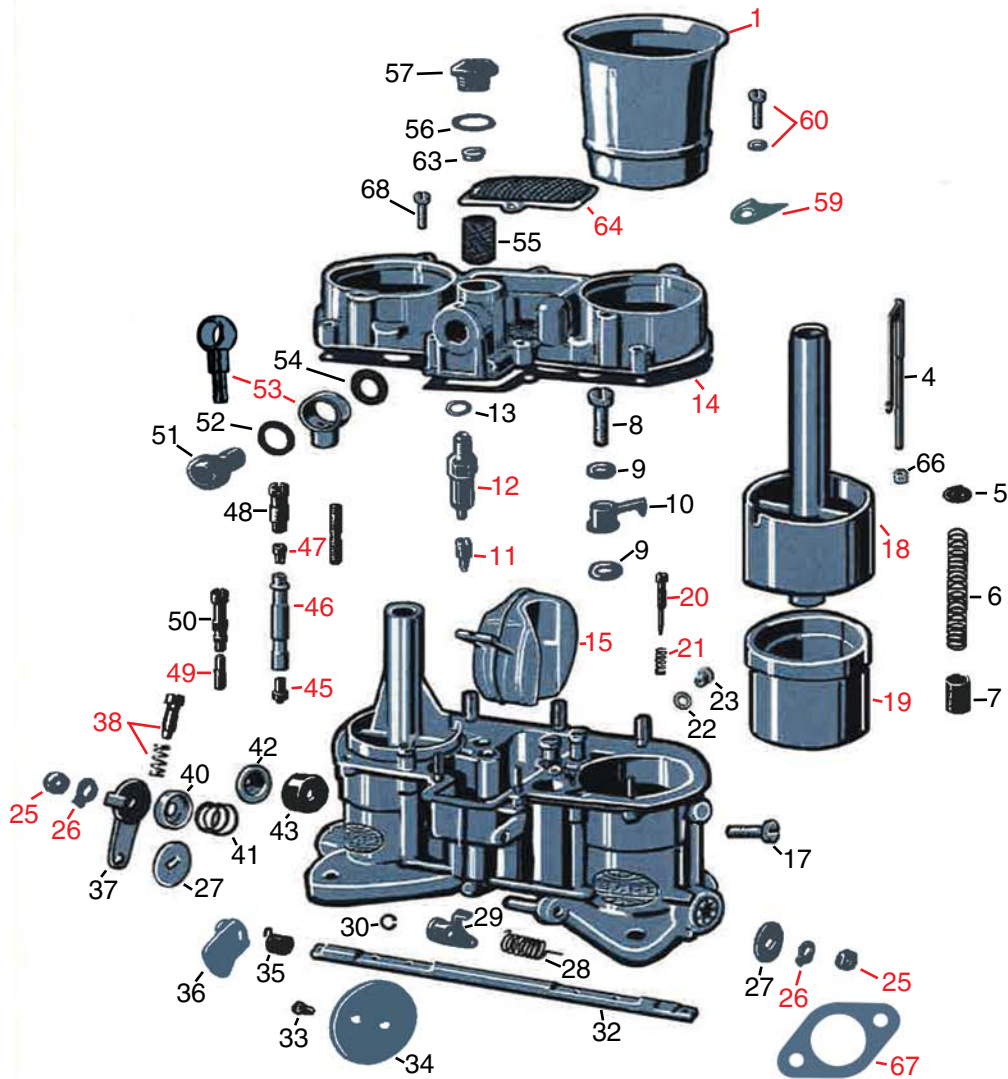

Only Items in **RED** are available separately as Components

 Included in 43-5815 Rebuild Kit

If not in **Red** it is not available separately.

If it is in **Red** and **Circled** it is available separately or in the Rebuild Kit.

If it is **Black** and **Circled** it is only available in a Rebuild Kit.

All other items are for Reference ONLY and are not available separately or in any Rebuild Kit.





# INTAKE - CARBURETOR SCHEMATICS

**EPC 48 / EPC 51**

**47-1048-0 / 47-1050-0**

Item #	Description	Part Number	Item #	Description	Part Number
1	Velocity Stack/Air Horn	43-6052	34	Throttle Valve	N/A
4	Pump Rod	N/A	35	Throttle return Spring	N/A
5	Spring Retaining Clip	N/A	36	Cam	N/A
6	Pump Spring	3252	37	Throttle Lever	N/A
7	Pump Plunger	N/A	38	Throttle Stop Screw & Spring	43-5346
8	Pump Demand Valve	N/A	40	Compression Spring Cover	N/A
9	Pump Jet Gasket	N/A	41	Compression Spring	N/A
10	Pump Jet	N/A	42	Dust Cap	N/A
11	Pump Exhaust Valve	43-5650 thru 43-6400	43	Bearing	N/A
12	Needle Valve - 3.0	43-5343	45	Main Jet	43-5301 thru 43-5321
13	Gasket, Needle Valve	N/A	46	Emulsion Tube	43-5670 thru 43-5681
14	Top Cover Gasket	43-5349	47	Air Correction Jet	43-5401 thru 43-5425
15	Float	43-6973	48	Emulsion Tube Holder	N/A
17	Float Spindle	N/A	49	Idle Jet	43-5536 thru 43-5543
18	Auxiliary Venturi	43-5353	50	Idle Jet Holder	N/A
19	Venturi/Choke	43-5618 thru 43-5619	51	Fuel Banjo Bolt	N/A
20	Idle Mixture Screw	43-5347	52	Fuel Banjo Gasket - Outer	N/A
21	Idle Mixture Spring	43-5347	53	Fuel Banjo	43-5355
22	O-ring	N/A	54	Fuel Banjo Gasket - Inner	N/A
23	Threaded Cover	N/A	55	Fuel Filter	N/A
25	Throttle Shaft Nut	43-6413	56	Fuel Filter Cover Gasket	N/A
26	Throttle Shaft Locking Tab	43-6414	57	Fuel Filter Cover	N/A
27	Washer	N/A	59	Velocity Stack/Air Horn Tab	43-5345
28	Throttle Return Spring	N/A	60	Bolt/Washer, Velocity Stack	43-5344
29	Pump Lever	N/A	63	Filter Locating Ring	N/A
30	Spring Washer	N/A	64	Main Jet Screen	43-5348
31	Pin	N/A	66	Pump Rod Bushing	N/A
32	Throttle Shaft	N/A	67	Base Gasket	3396
33	Throttle Shaft Screw	N/A	68	Body Screw	

Only Items in **RED** are available separately as Components

○ Included in 43-5815 Rebuild Kit

If not in **Red** it is not available separately.

If it is in **Red** and **Circled** it is available separately or in the Rebuild Kit.

If it is **Black** and **Circled** it is only available in a Rebuild Kit.

All other items are for Reference ONLY and are not available separately or in any Rebuild Kit.

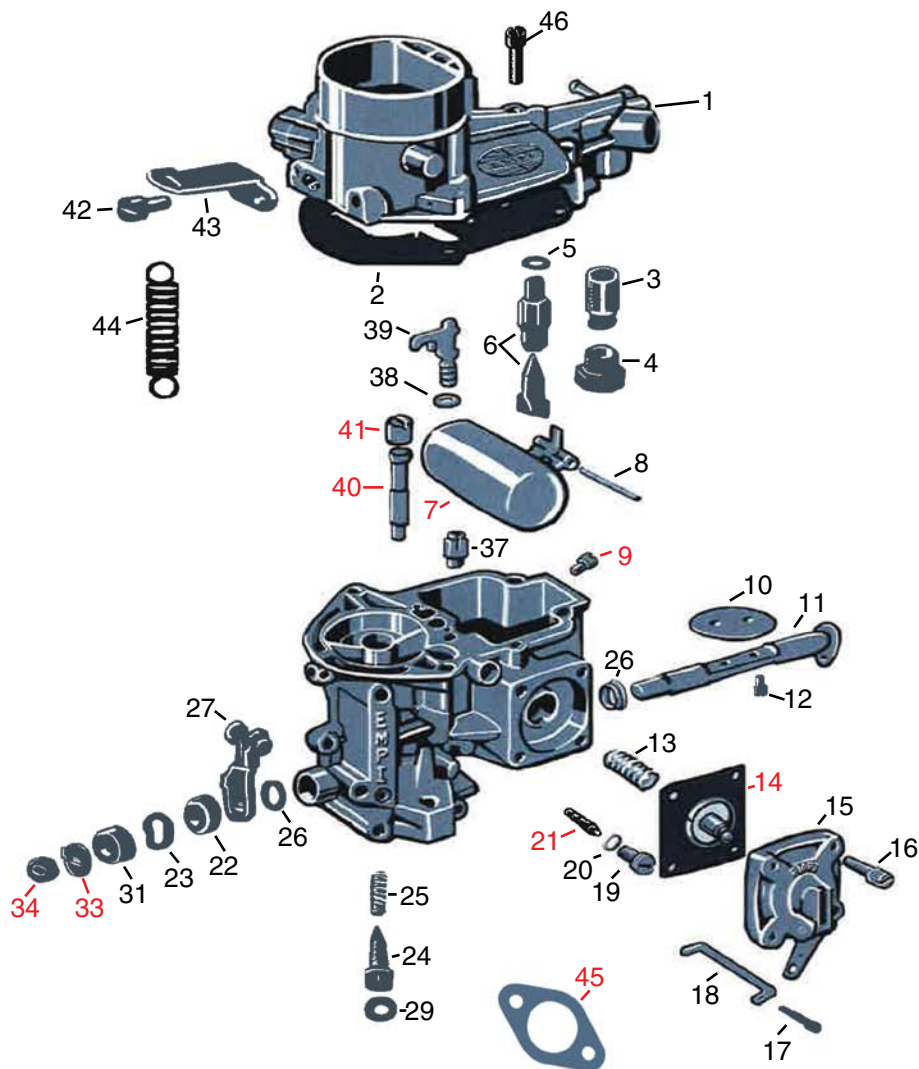

Only Items in **RED** are available separately as Components

**○** Included in 43-5801 Rebuild Kit

If not in **Red** it is not available separately.

If it is in **Red** and **Circled** it is available separately or in the Rebuild Kit.

If it is **Black** and **Circled** it is only available in a Rebuild Kit.

All other items are for Reference ONLY and are not available separately or in any Rebuild Kit.



# INTAKE - CARBURETOR SCHEMATICS

**EPC 34**

**43-1016-1**

Item #	Description	Part Number	Item #	Description	Part Number
1	Carburetor Top Cover	N/A	22	Fast Idle Control Lever Bushing	N/A
2	Carburetor Top Cover Gasket	N/A	23	Spring Washer	N/A
3	Fuel Filter	N/A	24	Idle Mixture Screw	N/A
4	Filter Inspection Plug	N/A	25	Idle Mixture Screw Spring	N/A
5	Needle Valve Gasket	N/A	26	Shaft Seal	N/A
6	Needle Valve	N/A	27	Throttle Control Lever	N/A
7	Float	43-6820	29	Idle Tamper-Proof Plug	N/A
8	Float Pin	N/A	31	Fast Idle Control Lever Bushing	N/A
9	Main Jet	43-5322 thru 43-5342	33	Throttle Shaft Locking Tab	43-6414
10	Throttle Plate	N/A	34	Throttle Shaft Nut	43-6413
11	Throttle Shaft	N/A	37	Pump Inlet Valve	N/A
12	Throttle Plate Screw	N/A	38	Pump Jet Gasket	N/A
13	Pump Loading Spring	N/A	39	Pump Jet	N/A
14	Accelerator Pump Diaphragm	43-5728	40	Emulsion Tube	43-5682 thru 43-5685
15	Accelerator Pump Cover	N/A	41	Air Correction Jet	43-5426 thru 43-5444
16	Accelerator Pump Cover Screw	N/A	42	Return Spring Bracket Screw	N/A
17	Split Pin	N/A	43	Return Spring Bracket	N/A
18	Pump Operating Rod	N/A	44	Return Spring	N/A
19	Idle Jet Holder	N/A	45	Base Gasket	3316
20	Idle Jet Holder Gasket	N/A	46	Body Screw	
21	Idle Jet	43-5519 thru 43-5549			

Only Items in **RED** are available separately as Components

 Included in 43-5801 Rebuild Kit

If not in **Red** it is not available separately.

If it is in **Red** and **Circled** it is available separately or in the Rebuild Kit.

If it is **Black** and **Circled** it is only available in a Rebuild Kit.

All other items are for Reference ONLY and are not available separately or in any Rebuild Kit.

**34 PICT-3**

**98-1289-B**

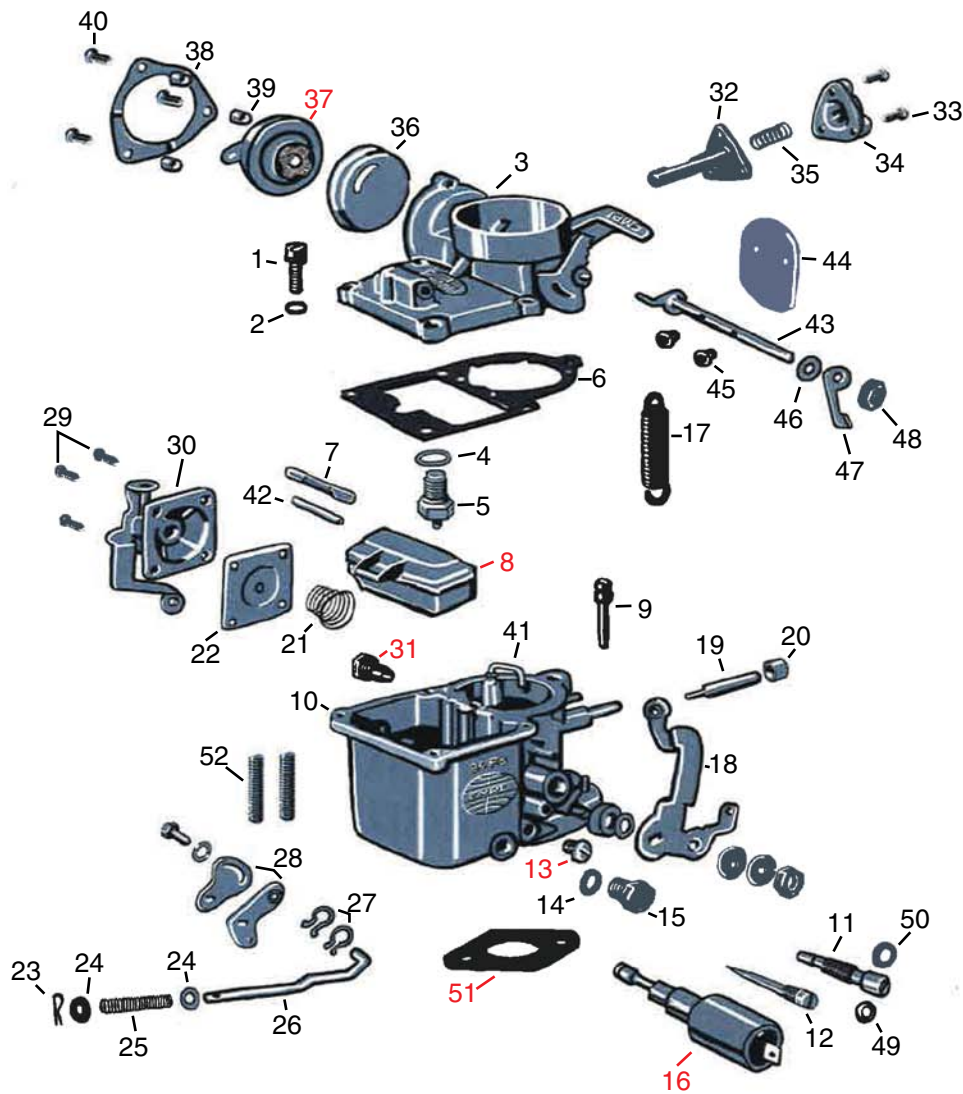

Only Items in **RED** are available separately as Components

**○** Included in 2500 Rebuild Kit

If not in **Red** it is not available separately.

If it is in **Red** and **Circled** it is available separately or in the Rebuild Kit.

If it is **Black** and **Circled** it is only available in a Rebuild Kit.

All other items are for Reference ONLY and are not available separately or in any Rebuild Kit.



# INTAKE - CARBURETOR SCHEMATICS

**34 PICT-3**

**98-1289-B**

Item #	Description	Part Number	Item #	Description	Part Number
1	Carburetor Top Screw	N/A	27	Clip	
2	Carburetor Top Spring Washer	N/A	28	Bell Crank Lever	
3	Carburetor Top	N/A	29	Accelerator Pump Cover Screw	
④	Needle Valve Washer		30	Accelerator Pump Cover	
⑤	Needle Valve		31	Pilot Jet	43-5045 thru 43-5070
⑥	Carburetor Top Gasket		③②	Vacuum Diaphragm	
⑦	Float retainer		33	Vacuum Diaphragm Cover Screw	
8	Float	43-6824	34	Vacuum Diaphragm Cover	
9	Air Correction Jet/Emulsion Tube		35	Vacuum Diaphragm Spring	
10	Carburetor Body		36	Plastic Cap	
⑪	Bypass Screw		37	Choke Element	98-1305-B
⑫	Volume Control Screw		38	Choke Element Retaining Ring	
13	Main Jet	43-5112 thru 43-5170	39	Choke Element Retaining Ring Spacer	
⑭	Plug Washer		40	Choke Element Retaining Ring Screw	
15	Plug		41	Accelerator Pump Injection Pipe	
16	Bypass Air Cut-Off Valve	98-1297-B	④②	Float Pin	
17	Return Spring		43	Choke Shaft	
18	Throttle Valve Lever		44	Choke Plate	
19	Throttle Valve Lever Stop Screw		45	Choke Plate Screw	
20	Throttle Valve Lever Stop Screw Nut		46	Choke Plate Shaft Washer	
21	Accelerator Pump Diaphragm Spring		47	Choke Lever	
②②	Accelerator Pump Diaphragm		48	Choke Shaft Nut	
23	Cotter Pin		④⑨	Air Volume Screw Gasket	
24	Washer		⑤①	Bypass Screw Gasket	
25	Connecting Rod Spring		⑤①	Carburetor Base Gasket	3253
26	Connecting Rod		52	Carburetor Base Stud	

Only Items in **RED** are available separately as Components

○ Included in 2500 Rebuild Kit

If not in **Red** it is not available separately.

If it is in **Red** and **Circled** it is available separately or in the Rebuild Kit.

If it is **Black** and **Circled** it is only available in a Rebuild Kit.

All other items are for Reference ONLY and are not available separately or in any Rebuild Kit.

30 PICT-1

98-1288-B / 98-1287-B

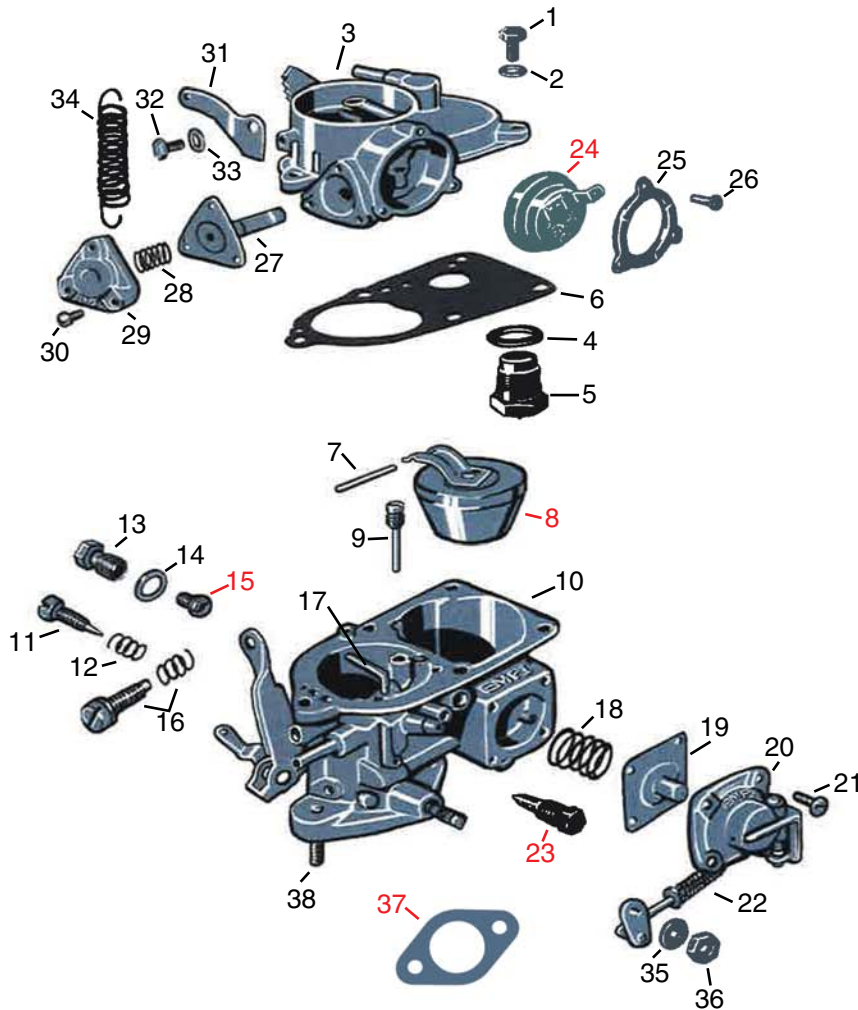

Only Items in **RED** are available separately as Components

**○** Included in 2500 Rebuild Kit

If not in **Red** it is not available separately.

If it is in **Red** and **Circled** it is available separately or in the Rebuild Kit.

If it is **Black** and **Circled** it is only available in a Rebuild Kit.

All other items are for Reference ONLY and are not available separately or in any Rebuild Kit.



# INTAKE - CARBURETOR SCHEMATICS

30 PICT-1

98-1288-B / 98-1287-B

Item #	Description	Part Number	Item #	Description	Part Number
1	Carburetor Top Screw	N/A	20	Accelerator Pump Cover	N/A
2	Carb. Top Spring Washer	N/A	21	Acc. Pump Cover Screw	N/A
3	Carburetor Top	N/A	22	Connecting Rod Assembly	N/A
4	Needle Valve Washer	N/A	23	Pilot Jet	43-5045 thru 43-5070
5	Needle Valve	N/A	24	Choke Element	98-1305-B
6	Carburetor Top Gasket	N/A	25	Choke Retaining Ring	N/A
7	Float Pin	N/A	26	Choke Retaining Ring Screw	N/A
8	Float	43-6822	27	Vacuum Diaphragm	N/A
9	Air Corr. Jet/Emulsion Tube	N/A	28	Vacuum Diaphragm Spring	N/A
10	Carburetor Body	N/A	29	Vacuum Diaphragm Cover	N/A
11	Volume Control Screw	N/A	30	Vacuum Dia. Cover Screw	N/A
12	Vol.Control Screw Spring	N/A	31	Return Spring Bracket	N/A
13	Plug	N/A	32	Return Spring Bracket Screw	N/A
14	Plug Washer	N/A	33	Return Spring Bkt. Washer	N/A
15	Main Jet	43-5112 thru 43-5170	34	Return Spring	N/A
16	Throttle Lever Screw/ Spring	N/A	35	Throttle Lever Locking Tab	N/A
17	Accelerator Pump Injection Pipe	N/A	36	Throttle Lever Nut	N/A
18	Acc. Pump Dia. Spring	N/A	37	Carburetor Base Gasket	3254
19	Acc. Pump Diaphragm	N/A	38	Carburetor Base Stud	N/A

Only Items in **RED** are available separately as Components

 Included in 2500 Rebuild Kit

If not in **Red** it is not available separately.

If it is in **Red** and **Circled** it is available separately or in the Rebuild Kit.

If it is **Black** and **Circled** it is only available in a Rebuild Kit.

All other items are for Reference ONLY and are not available separately or in any Rebuild Kit.

# INTAKE - CARBURETOR SCHEMATICS



**EPC 38E**

**47-0628-7 / 44-1005-1 / 44-1006-1**

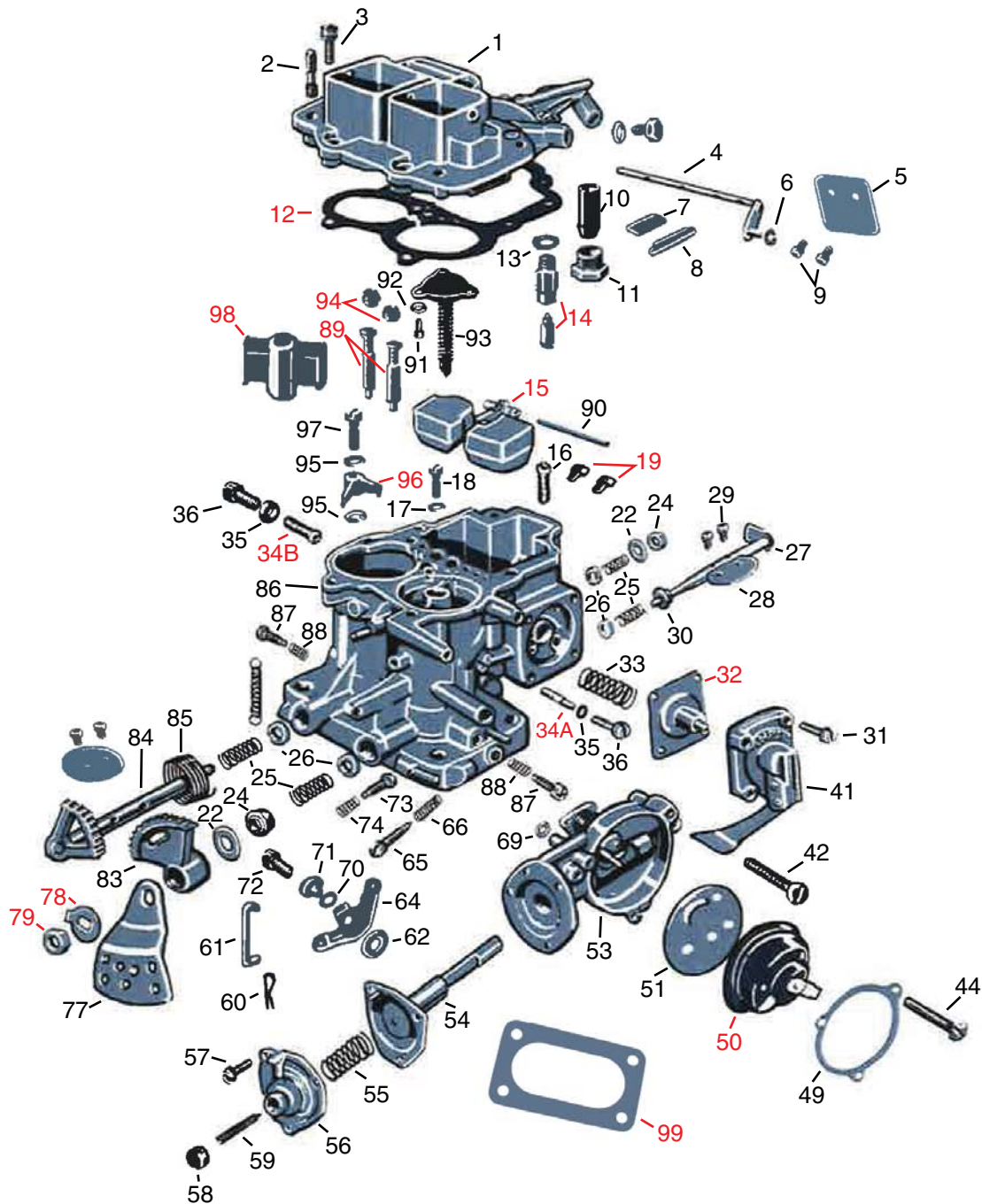

Only Items in **RED** are available separately as Components

 Included in 43-5802 Rebuild Kit

If not in **Red** it is not available separately.

If it is in **Red** and **Circled** it is available separately or in the Rebuild Kit.

If it is **Black** and **Circled** it is only available in a Rebuild Kit.

All other items are for Reference ONLY and are not available separately or in any Rebuild Kit.





# INTAKE - CARBURETOR SCHEMATICS

**EPC 38E**

**47-0628-7 / 44-1005-1 / 44-1006-1**

Item #	Description	Part Number	Item #	Description	Part Number
1	Carburetor Top Cover	N/A	53	Auto Choke Body	N/A
2	Air Cleaner Stud	N/A	54	Choke Diaphragm	N/A
3	Carburetor Top Cover Screw	N/A	55	Choke Diaphragm Spring	N/A
4	Choke Shaft & Lever	N/A	56	Auto Choke Cover	N/A
5	Start Throttle Valve Plate	N/A	57	Auto Choke Cover Screw	N/A
6	Spring Ring	N/A	58	Plug	N/A
7	Dust Seal Plate	N/A	59	Diaphragm Adjusting Screw	N/A
8	Dust Seal Plug	N/A	60	Fast Idle Rod Pin	N/A
9	Choke Plate Screw	N/A	61	Fast Idle Control Rod	N/A
10	Fuel Filter	N/A	62	Fast Idle Loose Lever Washer	N/A
11	Filter Plug	N/A	64	Fast Idle Loose Lever	N/A
12	Carburetor Top Cover Gasket	3248	65	Screw	N/A
13	Needle Valve Gasket	N/A	66	Spring	N/A
14	Needle Valve	43-5371 thru 43-5374	69	Auto Choke O' Ring	N/A
15	Float	43-6550	70	Fast Idle Lever Washer	N/A
16	Pump Discharge Needle	N/A	71	Fast Idle Idle Lever Bushing	N/A
17	Power Valve Gasket	N/A	72	Fast Idle Loose Lever Screw	N/A
18	Power Valve	N/A	73	Throttle Adjusting Screw	N/A
19	Main Jet	43-5322 thru 43-5342	74	Throttle Adj. Screw Spring	N/A
22	Secondary Shaft Washer	N/A	77	Throttle Control Lever	N/A
24	Secondary Shaft Nut	N/A	78	Throttle Lever Locking Tab	43-6414
25	Bushing Retaining Spring	N/A	79	Throttle Lever Nut	43-6413
26	Shaft Bushing	N/A	83	Primary Toothed Sector	N/A
27	Primary Main Shaft Assy.	N/A	84	Secondary Main Shaft	N/A
28	Throttle Plate	N/A	85	Sec. Shaft Return Spring	N/A
29	Throttle Plate Screw	N/A	86	Carburetor Body	N/A
30	Spacer	N/A	87	Idle Adjusting Screw	N/A
31	Accelerator Pump Cover Screw	N/A	88	Idle Adjusting Screw Spring	N/A
32	Accelerator Pump Diaph.	43-5727	89	Emulsion Tube	43-5682 thru 43-5685
33	Pump Loading Spring	N/A	90	Float Pin	N/A
34A	Idle Jet - Primary	43-5519 thru 43-5549	91	Power Valve Screw	N/A
34B	Idle Jet - Secondary	43-5501 thru 43-5508	92	Washer	N/A
35	Idle Jet Holder Gasket	N/A	93	Power Valve	N/A
36	Idle Jet Holder	N/A	94	Air Correction Jet	43-5426 thru 43-5444
41	Accelerator Pump Cover	N/A	95	Acc. Pump Jet Gasket	N/A
42	Choke Screw	N/A	96	Accelerator Pump Jet	43-5391 thru 43-5398
44	Lock Ring Screw	N/A	97	Pump Delivery Valve	N/A
49	Choke Element Lock Ring	N/A	98	Auxiliary Venturi	43-5687
50	Choke Element	43-5351	99	Base Gasket	3411
51	Auto Choke Body Gasket	N/A			

# INTAKE - CARBURETOR SCHEMATICS



40 / 44 HPMX

47-1010-0 / 47-1010-2  
47-1012-0 / 47-1012-2

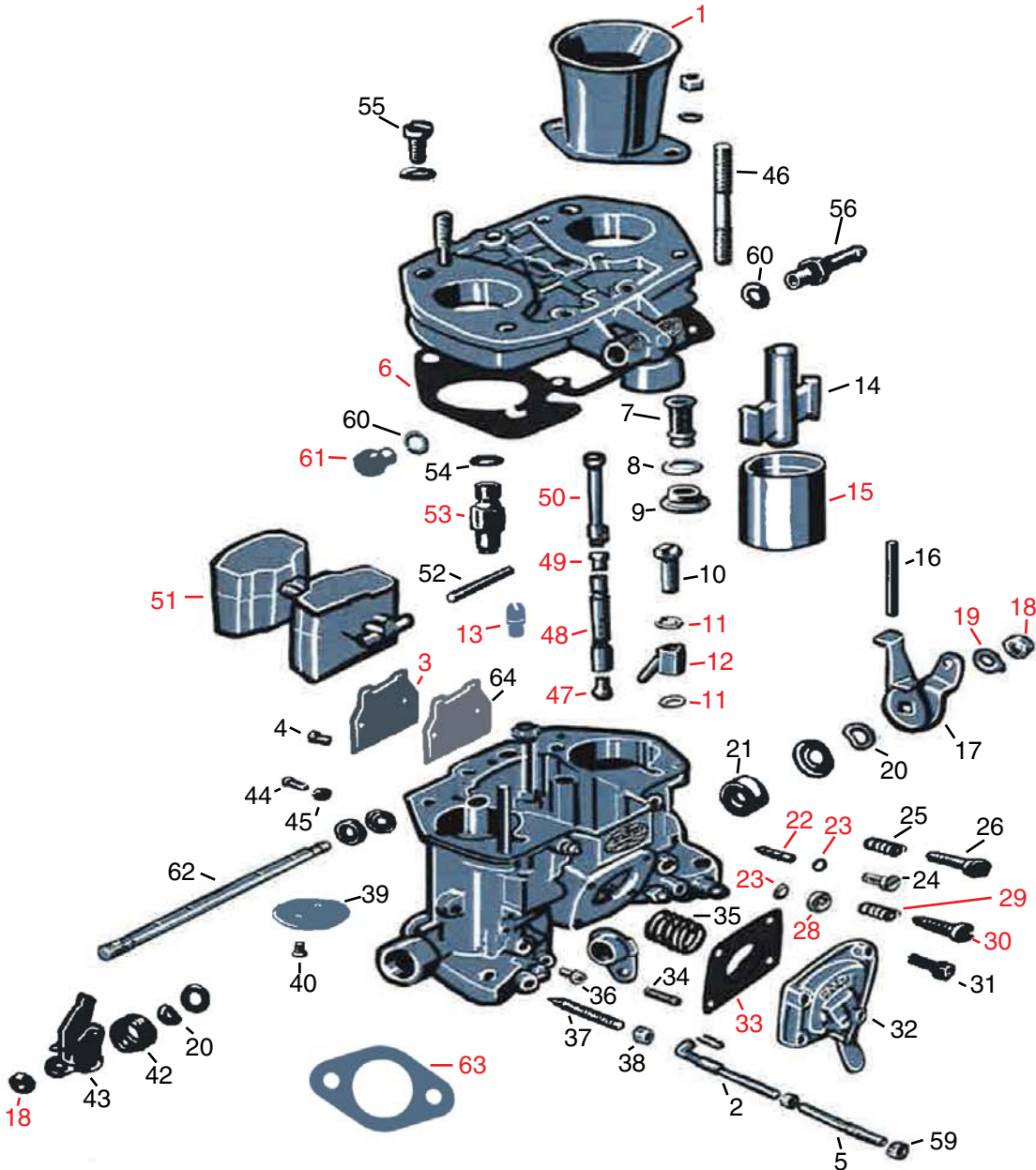

Only Items in **RED** are available separately as Components

 Included in 43-5813 Rebuild Kit

If not in **Red** it is not available separately.

If it is in **Red** and **Circled** it is available separately or in the Rebuild Kit.

If it is **Black** and **Circled** it is only available in a Rebuild Kit.

All other items are for Reference ONLY and are not available separately or in any Rebuild Kit.



# INTAKE - CARBURETOR SCHEMATICS

40 / 44 HPMX

47-1010-0 / 47-1010-2  
47-1012-0 / 47-1012-2

Item #	Description	Part Number	Item #	Description	Part Number
1	Velocity Stack/Air Horn	43--1551-1	31	Pump Cover Screw	N/A
2	Pump Control Rod	N/A	33	Accelerator Pump Diaphragm	43-5725
3	Enrichment Block-Off Plate	43-5709	34	Roll Pin	N/A
4	Block-Off Plate Screw	N/A	35	Pump Diaphragm Spring	N/A
5	Pump Rod Spring	N/A	36	Vacuum Tube Cover	N/A
6	Carburetor Main Gasket	3252	37	Air By-Pass Screw	N/A
7	Fuel Filter	N/A	38	Air By-Pass Screw Nut	N/A
8	Fuel Filter Gasket	N/A	39	Throttle Plate	N/A
9	Fuel Filter Cover	N/A	40	Throttle Plate Screw	N/A
10	Pump Demand Valve	N/A	41	Air Filter/Horn Gasket (Not Shown)	3210
11	Pump Jet Washer	43-6410	42	Throttle Return Spring	N/A
12	Accelerator Pump Jet	43-5388 thru 43-5390	43	Throttle Lever	N/A
13	Pump Exhaust Valve	43-5650 thru 43-6400	44	Choke Tube Screw	N/A
14	Auxiliary Venturi	N/A	45	Choke Tube Screw Nut	N/A
15	Venturi/Choke	43-5606 thru 43-5611	46	Stud	N/A
16	Stud	N/A	47	Main Jet	43-5301 thru 43-5321
17	Throttle Lever	N/A	48	Emulsion Tube	43-5670 thru 43-5681
18	Throttle Shaft Nut	43-6413	49	Air Correction Jet	43-5401 thru 43-5425
19	Throttle Shaft Locking Tab	43-6414	50	Emulsion Tube Holder	43-6440
20	Spring Ring	N/A	51	Float	43-6441
21	Throttle Shaft Bearing	N/A	52	Float Pin	N/A
22	Idle Jet	43-5510 thru 43-5518	53	Needle Valve	43-5366 thru 43-5368
23	Idle Jet O' Ring	43-6417	54	Needle Valve Gasket	N/A
24	Idle Jet Holder	N/A	55	Top Cover Screw	N/A
25	Throttle Stop Screw Spring	N/A	56	Fuel Inlet Fitting	N/A
26	Throttle Stop Screw	N/A	60	Fuel Inlet Fitting Gasket	N/A
28	Mixture Screw O' Ring Cap	43-6422	61	Threaded Cap/Fuel Inlet	43-6552
29	Mixture Screw Spring	43-6423	62	Throttle Shaft	N/A
30	Mixture Screw	43-6424	63	Base Gasket	3396
32	Pump Cover	N/A	64	Block Off Gasket	N/A

Only Items in **RED** are available separately as Components

○ Included in 43-5813 Rebuild Kit

If not in **Red** it is not available separately.

If it is in **Red** and **Circled** it is available separately or in the Rebuild Kit.

If it is **Black** and **Circled** it is only available in a Rebuild Kit.

All other items are for Reference ONLY and are not available separately or in any Rebuild Kit.

# INTAKE - CARBURETOR SCHEMATICS



**EPC 32 / 36F**

**44-1018-1 / 47-0634-7  
47-0670-7 / 47-0800-7**

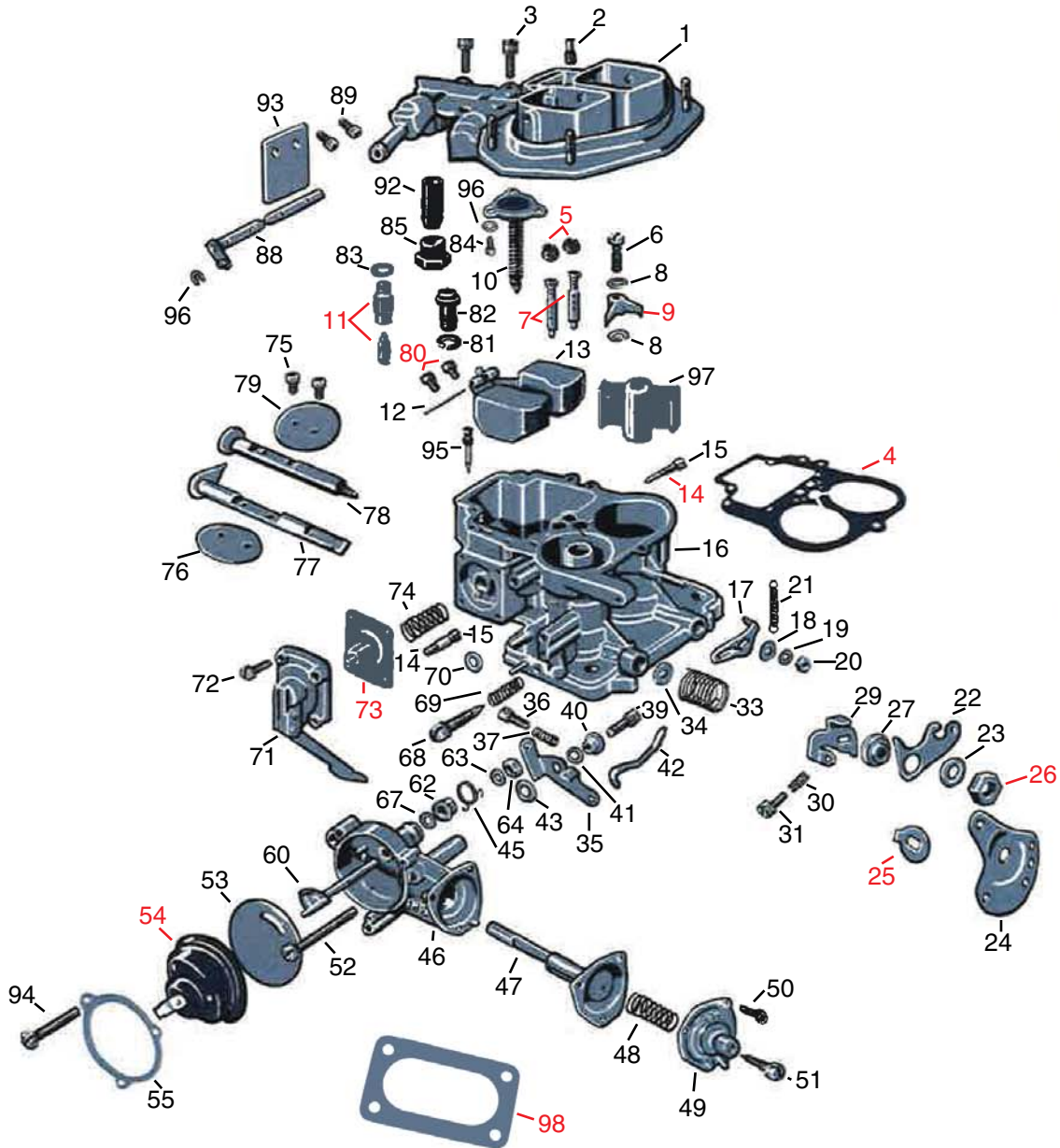

Only Items in **RED** are available separately as Components

**○** Included in 43-5804 Rebuild Kit

If not in **Red** it is not available separately.

If it is in **Red** and **Circled** it is available separately or in the Rebuild Kit.

If it is **Black** and **Circled** it is only available in a Rebuild Kit.

All other items are for Reference ONLY and are not available separately or in any Rebuild Kit.



# INTAKE - CARBURETOR SCHEMATICS

EPC 32 / 36F

44-1018-1 / 47-0634-7 / 47-0670-7 / 47-0800-7

Item #	Description	Part Number	Item #	Description	Part Number
1	Carburetor Top Cover	N/A	(47)	Choke Diaphragm	N/A
2	Air Cleaner Stud	N/A	48	Choke Diaphragm Spring	N/A
(3)	Carburetor Top Cover Screw	N/A	49	Choke Diaphragm Cover	N/A
(4)	Carburetor Top Cover Gasket	3249	50	Choke Diaphragm Cover Screw	N/A
5	Air Correction Jet	43-5426 thru 43-5444	51	Choke Diaphragm Screw	N/A
6	Pump Delivery Valve	N/A	52	Choke Assembly Screw	N/A
7	Emulsion Tube	43-5682 thru 43-5685	(53)	Choke Cover - Plastic	N/A
(8)	Pump Jet Gasket	N/A	54	Choke Element	43-0620
9	Accelerator Pump Jet	43-5391 thru 43-5398	55	Choke Element Holding Ring	N/A
(10)	Pump Valve	N/A	60	Choke Shaft	N/A
(11)	Needle Valve	43-5371 thru 43-5374	62	Spring	N/A
(12)	Float Pin	N/A	63	Washer	N/A
(13)	Float	N/A	64	Nut	N/A
14	Idle Jet	43-5501 thru 43-5508	67	Washer	N/A
15	Idle Jet Holder	N/A	68	Screw	N/A
16	Carburetor Body	N/A	69	Spring	N/A
17	Secondary Lever	N/A	70	Gasket	N/A
18	Washer	N/A	71	Accelerator Pump Cover	N/A
19	Washer	N/A	72	Accelerator Pump Cover Screw	N/A
20	Nut	N/A	(73)	Accelerator Pump Diaphragm	43-5726
21	Spring	N/A	74	Spring	N/A
22	Loose Lever	N/A	75	Screw	N/A
23	Washer	N/A	76	Primary Throttle Plate	N/A
24	Throttle Lever	N/A	77	Primary Shaft	N/A
25	Throttle Lever Locking Tab	43-6414	78	Secondary Shaft	N/A
26	Throttle Lever Nut	43-6413	79	Secondary Throttle Plate	N/A
27	Bushing	N/A	80	Main Jet	43-5322 thru 43-5342
29	Lever	N/A	81	Power Valve Gasket	N/A
30	Spring	N/A	82	Power Valve	N/A
31	Screw	N/A	(83)	Gasket	N/A
33	Spring	N/A	84	Screw	N/A
34	Washer	N/A	(85)	Fuel Filter Plug	N/A
35	Lever	N/A	88	Choke Shaft	N/A
36	Screw	N/A	89	Screw	N/A
37	Spring	N/A	92	Fuel Filter	N/A
39	Screw	N/A	93	Choke Plate	N/A
40	Bushing	N/A	94	Choke Element Holding Ring Screw	N/A
41	Washer	N/A	95	Pump Needle	N/A
42	Rod	N/A	96	Washer	N/A
43	Washer	N/A	97	Auxiliary Venturi	N/A
45	Spring	N/A	98	Base Gasket	3409/3410
46	Auto Choke Body Assembly	N/A			



## EMPI CARBURETOR TUNE-UP KITS

The kits in section 1 are basic repair kits and come complete with needle/seat, all necessary o-rings and gaskets. The kits in section 2 are considered overhaul kits with all necessary components included. Some kits come with floats and accelerator pump diaphragms as noted.

Application	Accelerator Pump		
	Diaphragm Incl.	Boxed	Skinpacked
Universal VW Solex (Ref. P/N: 113 198 575URK)	Y	2500	9936
VW Type 1, 40HP (Ref. P/N: 111 198 569C)	Y	2355	X
VW Type 2, 73-74, Type 3, 64-67	Y	2231	9939
WEBER Progressive, DFV, Holley 5200, EPC 32/36F (VW)	Y	2202	9932
WEBER 34 ICT, EPC 34	Y	2365	9951
WEBER 32/36 DGV5A, EPC 32/36 (JEEP, SUZUKI, TOYOTA)	Y	2361	9947
WEBER 34 ICH, EPC 34X	Y	2365	9951
WEBER 40/45/DCOE	N	2367	X
WEBER 48/50/55 DCO	N	2367	X
WEBER 40 DCNF	Y	2345	9948
WEBER 40-44 IDF/40-44 HPMX (with Late Model Diaphragm)	Y	2362	9949
WEBER 38 DGAS/DGES, EPC 38	Y	2361	9947
Dellorto 36-40 DRLA	Y	2364	9950
Holley Bug Spray	N	2238	9933
Zenith 32NDIX - Minor	N	2258	9934
EMPI/Brosol (Kadron) 40/44 EIS	Y	2301	9937

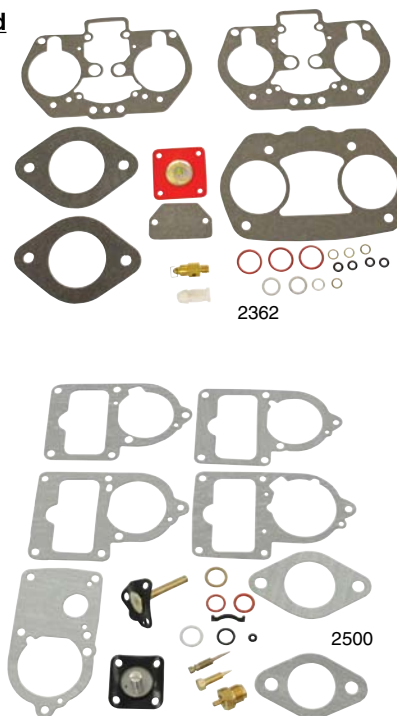

## ACCELERATOR PUMP DIAPHRAGMS

- 43-5725** For 40/44 HPMX, 40/44 IDF, Each
- 43-5726** For EPC 32/36F, 32/36 DFV, Each
- 43-5727** For EPC 38E, 38 DGS, Each
- 43-5728** For EPC 34, 34 ICT, Each



## EMPI OVERHAUL / REBUILD KITS (BOXED)

Reference Carburetor Type	EMPI Kit	Acc. Pump Dia. Incl.	Float Incl.	Reference Carburetor Type	EMPI Kit	Acc. Pump Dia. Incl.	Float Incl.
34 ICH, EPC 34X	43-5800	Y	Y	45 DCOE Paper T/Cvr. (1.75 N/Seat)	43-5808	N	Y
34 ICT, EPC 34	43-5801	Y	Y	45 DCOE Paper T/Cvr. (2.00 N/Seat)	43-5809	N	Y
32/36 DGV, DGAV, DGEV (JEEP / SUZUKI / TOYOTA)	43-5802	Y	Y	48 DCO SP Paper T/Cvr. (1.75 N/Seat)	43-5808	N	Y
EPC 32/36E, EPC 32/36A, EPC 32/36M (JEEP / SUZUKI / TOYOTA)	43-5802	Y	Y	48 DCO SP Paper T/Cvr. (2.00 N/Seat)	43-5809	N	Y
32/36 DFEV, EPC 32/36F (VW)	43-5804	Y	Y	48 IDA, EPC 48/51	43-5815	N	Y
40 DCOE Paper T/Cvr. (1.75 N/Seat)	43-5808	N	Y	50 DCO/DCO 1SP Paper T/Cvr. (1.75 N/Seat)	43-5808	N	Y
40 DCOE Paper T/Cvr. (2.00 N/Seat)	43-5809	N	Y	50 DCO/DCO 1SP Paper T/Cvr. (2.00 N/Seat)	43-5809	N	Y
40 DCNF	43-5810	Y	Y	55 DCO/DCO 1SP Paper T/Cvr. (1.75 N/Seat)	43-5808	N	Y
40 IDF/40 HPMX	43-5813	Y	Y	55 DCO/DCO 1SP Paper T/Cvr. (2.00 N/Seat)	43-5809	N	Y
44 IDF/44 HPMX	43-5813	Y	Y				



# INTAKE - CARB. KITS & COMPONENTS

98-1289-B  
(34 PICT-3)



70 Air  
127.5 Main  
55 Idle

## STOCK REPLACEMENT CARBURETORS

EMPI now has available stock replacement carburetors for most of the popular applications. Whether it's to just keep your car running or a full blown restoration, we have the carburetor that's right for you. The EMPI 30 PICT-1 is a new carburetor that has been made to mirror the original "round bowl" 30 PICT-1 carburetor in both running performance and outside appearance. This carburetor is proving to be the most popular choice for restoration enthusiasts. This carburetor is now SCORE approved for classes 1-2/1600, 5/1600, 9, 11. We also offer an EMPI version of the popular 34 PICT-3 carburetor that has also been engineered "true to the original". This carburetor will cover all 1600cc dual port engine requirements. Stock carburetors from Brosol/Solex are also available along with the most

common replacement/service items. EMPI carburetors include gasket and studs. The 34 PICT-3 also includes a jet pack for high ethonal fuels and/or header.

**NEW ADJUSTABLE FLOAT**  
(34 PICT-3)



98-1288-B  
(30 PICT-1)

**SCORE APPROVED**

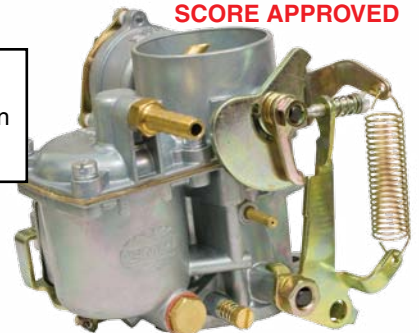

115 Air  
120 Main  
55 Idle

### EMPI MODIFIED 30 PICT-1 Carburetor for Off-Road Vehicles

For the hardcore competitor we here at EMPI offer a modified version of our popular 30 PICT-1 carburetor. This new carburetor has been Baja 1000 tested and is SCORE approved with all the features of a winner. The float bowl has been externally vented to help avoid fuel-slosh and flooding on rough terrain and the old vent tube has been removed and plugged. The fuel inlet has been threaded and a screw-in fitting is supplied. Dual return springs alleviate the chance of a stuck open throttle. The choke assembly has been removed and plugged on both sides. This is a serious and well thought-out carburetor but will still require re-jetting for your performance application.

**98-1289-B** EMPI 34 PICT-3 Carb.  
(Ref. P/N: 113 129 031KE) Will clear alternator on late model applications  
12-Volt Choke  
**43-6824** Replacement Float for 98-1289-B, 98-1292-B, 98-1225-B

**98-1288-B** EMPI 30 PICT-1 Carb.  
(Ref. P/N: 113 129 027E) 12-Volt Choke  
**Score Approved Classes 1-2/1600, 5/1600, 9, 11**  
**43-6822** Replacement Float for 98-1287-B and 98-1288-B

**98-1287-B** EMPI Modified 30 PICT-1 Carb  
**Score Approved Classes 1-2/1600, 5/1600, 9, 11 (Off-Road Only)**

43-6824



43-6822

115 Air  
120 Main  
55 Idle

98-1287-B  
(30 PICT-1)  
Baja Tested  
**Score Approved**  
**Off-Road Only**

### EMPI 30 / 31 PICT-3 Carburetor

Recommended for all engine sizes up to 1600cc for ease of set up, the 30/31 PICT-3 fits both Single and Dual Port Manifolds and works well with the 009 distributor with less chance of flat spots. It features a 12-Volt Idle Shut-Off Solenoid, has a SVDA Vacuum Port and is a direct replacement for all 12-Volt 30PICT Single Port applications. Customer can remove adapter for use on 30mm 67-70 models.

**98-1225-B** 30/31 PICT-3 Carburetor with Adapter and Hardware  
(Ref. P/N: 113 129 027H)

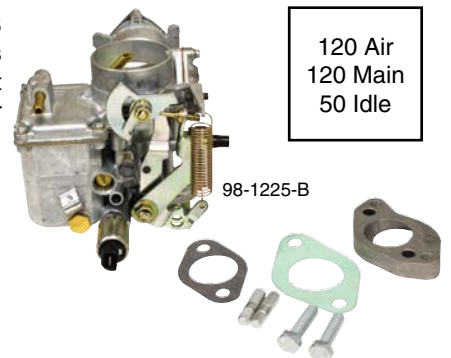

98-1225-B

120 Air  
120 Main  
50 Idle

(See page 99 for replacement jets)

115 Air  
120 Main  
55 Idle



## **BROSOL / SOLEX PICT CARBURETORS**

### **31 PICT-3 CARBURETOR W/ ADAPTER**

Now you can run the 31 PICT-3 carburetor on your Dual Port manifold, replacing the stock, smog-era 34 PICT-3 carb. Comes complete with Carburetor, adapter, gaskets and hardware for a simple installation. Fits most stock Dual Port intake manifolds.

**98-1292-B** Brosol/Solex Carburetor Only.  
31 PICT-3, Dual Arm, 12-Volt Choke.  
(Ref. P/N: 113 129 029A)

**98-1300-B** 31 PICT-3 Carburetor with Adapter Kit.

(See page 99 for replacement jets)

### **SINGLE PORT MANIFOLD**

**98-1311-B** Intake Manifold, Single Port, 1500-1600cc,  
30mm Base, Type 1 66-70, Ghia 66-70, Type 2 64-70  
(Ref. P/N: 113 129 701K)



30/31 PICT-1

34 PICT-3

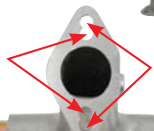

### **DUAL PORT 30 / 31 / 34 PICT MANIFOLD**

This manifold allows for the use of 30 PICT-1, 31 PICT-3 or 34 PICT-3 carburetors without adapters. Manifold flange is drilled for either stud pattern and comes with heat risers, gaskets, and 1/8" pipe plug. Drilled and tapped for optional vacuum advance.

**17-2805** 30 / 31 / 34 Intake Manifold, Kit  
(Ref. P/N: 113 129 701AQ)

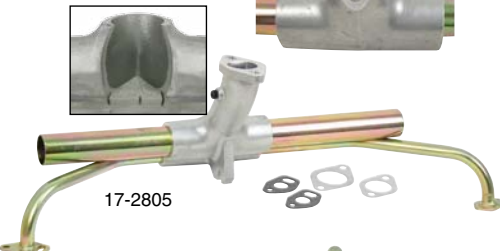

### **CARBURETOR ACCESSORIES**

#### **ADAPTER KIT - SCORE LEGAL**

**98-1293-B** Adapter Kit to use a 30 or 30/31 Carburetor on a Dual Port  
(34Pict) Intake Manifold.  
(Ref. P/N: 113 129 034KIT)  
(Called out by EMPI part number in the SCORE rule book)



#### **AIR BY-PASS VALVE**

**98-1297-B** Idle Shut-Off Valve, 12 Volt. Fits 34-3, 34-4 and  
34 PDSIT 2/3 Carburetors.  
(Ref. P/N: 049 129 412C)



#### **CHOKE**

**98-1305-B** Choke Unit, 12-Volt. Fits 67 and later 30, 30/31 and 34 PICT  
models of EMPI, Brosol, Bocar and Solex Carburetors.  
(Ref. P/N: 113 129 191G)



### **REPLACEMENT CHOKE ELEMENTS**

**43-0620** Repl. Electric Choke Only for EPC 32/36F, 32/36 DFEV.  
**43-5351** Repl. Electric Choke Only for EPC 32/36, EPC 38,  
32/36 DGEV, 38 DGES



43-0620





# INTAKE - ACCESSORIES, JETS & MISC.

## EMPI STOCK-STYLE DUAL PORT END CASTING KIT

Stock-Style Dual Port End Castings for the look and fit of stock. Comes complete with necessary clamps and new intake boots. Flange has notch in it. **New not rebuilt.**

**3238** Stock-Style Dual Port End Casting Kit, Type 1, 2 & 3  
(Ref. P/N: 113 129 710D/9G)



## DUAL PORT END KIT

Thick enough for Porting & Polishing. These new ball burnished Aluminum end castings come complete with necessary clamps and new intake boots.

**3236** Dual Port End Kit, Type 1, 2 & 3



## SINGLE PORT END KIT

Cast Aluminum Ends for use with Center Section Style manifolds with Single Port Heads. Complete with necessary clamps and crush rings.

**3237** Single Port End Kit, Type 1, 2 & 3  
**3413** Replacement Single Port Installation Kit



## DUAL PORT SPLIT INTAKE BOOTS

Revolutionary Split-Boot design puts an end to manifold vacuum leaks and installation headaches. I.D. of small end is 1 1/4". I.D. of large end is 1 1/2".

**9960** Split-Boot Intake Boots w/Clamps, Pair  
(Bulk P/N: 113 129 729BB, Each)



## DUAL PORT INSTALLATION KIT

Quality Step-Style Boots available in Red or Black. Now also available in Urethane. Clamps and quality dual port intake gaskets are included.

**3230** Dual Port Installation Kit - Red  
**3412** Dual Port Installation Kit - Black

**3231-B** Bulk Boot Only, Black, Each  
(Ref. P/N: 113 129 729B)

**3404-B** Bulk Boot Only, Red, Each  
(Ref. P/N: 113 129 729BS)

**3215** Intake Boot Clamp - Small, Pair, Skinpacked  
**3215-6** Bulk Small Intake Clamp, Ea  
**3216** Intake Boot Clamp - Large, Pair, Skinpacked  
**3216-6** Bulk Large Intake Clamp, Ea

**3403-B** Bulk Red Urethane D/P Boot, Each  
**3229** Dual Port Installation Kit utilizing Red Urethane Boots  
**3407-B** Bulk Black Urethane D/P Boot, Each  
**3228** Dual Port Installation Kit utilizing Black Urethane Boots



3215

3216



3407-B

3403-B

## UNIVERSAL NYLON A/C FITTING

**8998** Universal 90° Nylon Fitting w/Nylon Nut



## GASKETS - INTAKE, CARB BASE & AIR FILTER BASE

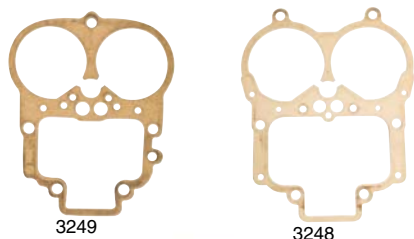

3249

3248



3252

### CARB CASTING GASKETS

- 3252 40/44 HPMX (IDF) Carb Casting Gasket, Pair
- 3248 38EGAS (DGV) Carb Casting Gasket, Pair
- 3249 32/36F (DFV) Carb Casting Gasket, Pair

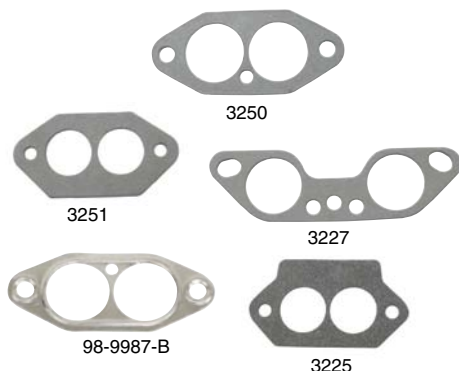

3250

3251

3227

98-9987-B

3225

### INTAKE MANIFOLD GASKETS

- 3250 Dual Port Gaskets, Pair
- 3251 Dual Port Gaskets w/o Pin Holes, Pair
- 3227 Type 2 & 4-1.7-2.0 L 3 & 4-Bolt Gaskets, Pair
- 3225 Dual Port Main Gasket for P/N: 43-5214, 43-5215, Pair
- 98-9987-B Dual Port Metal Gasket, Stock Style, Each  
(Ref P/N: 113 129 717A)

### CARB BASE GASKETS

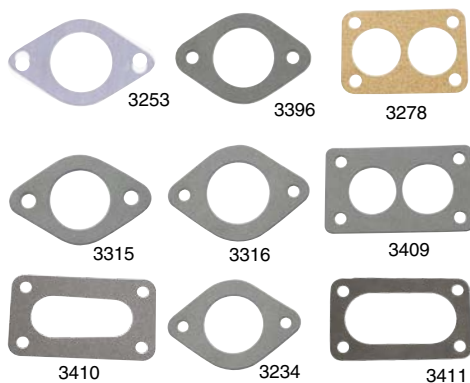

3253

3396

3278

3315

3316

3409

3410

3234

3411

- 3254 30 PICT 1 Base Gasket, Pair
- 3253 34 PICT 3 Base Gasket, Pair
- 3396 WEBER 40/44/48 IDA Gaskets, Pair
- 3278 WEBER 40/42 DCNF Gaskets, Pair
- 3315 40/44 IDF/DRLA Gaskets, Pair
- 3316 WEBER 34 ICT Gaskets, Pair
- 3399 Holley Bug Spray/Zenith, Pair
- 3409 Holley/WEBER DFV Gaskets, Isolated Type, Pair
- 3410 Holley/WEBER DFV Gaskets, Plenum Type, Pair
- 3234 EMPI/Solex/Brosol 40EIS Gaskets, Pair
- 3411 38EPC (DGS), 32/36 EPC (DGV) Gaskets, Pair



3254

3399

### AIR FILTER BASE GASKETS

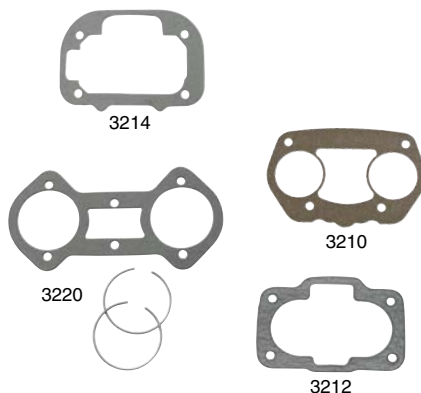

3214

3210

3220

3212

- 3210 WEBER IDF, HPMX, DRLA Gaskets, Pair
- 3211 WEBER DFV/Holley-WEBER Gaskets, Pair
- 3212 WEBER DCNF Gaskets, Pair
- 3213 WEBER DCOE Gaskets, Pair
- 3214 WEBER DGV, DGS Gaskets, Pair
- 3220 48 IDA Air Cleaner Base Gasket w/Velosity Stack Spacers, Pair
- 8800 Brosol/Solex Gaskets, Pair



3211

3213

8800

Note: Many Gaskets are available in Bulk. Ask your sales person for assistance.



# INTAKE - ACCESSORIES, JETS & MISC.

## UNIVERSAL PLASTIC IN-LINE FUEL FILTER

Quick and easy to install these inexpensive paper filters prevent dirt and sediment from clogging your carb. Fits both 5/16" and 1/4" fuel lines. (10 pieces per box, priced per box) 1 = 10pcs.

**9100** Universal Plastic Fuel Filter, Box of 10  
(Ref. P/N: 803 201 511C)



## UNIVERSAL GLASS SEE THROUGH FUEL FILTERS

Quick and easy to install, these see through glass filters have a plastic screen filter that prevents dirt and sediment from clogging your carb. Disassembles for easy cleaning or filter replacement. Now available with female threads on both ends of the filter. These new filters are supplied with three pair of plastic nylon fittings. This includes 1/4", 5/16", and 3/8" fittings for the corresponding fuel hose sizes.

### FUEL FILTERS

**9104** Fuel Filter Only with 1/4", 5/16", and 3/8" fittings  
**9109** Replacement Element, Pack of 2

### FUEL FILTER KIT

**9065** Fuel Filter Kit, w/Hose & Clamp,  
Fits 1/4", 5/16" and 3/8" fittings



## FUEL LINE

**98-1184-B** Steel Fuel Line, 26", Type 1, Ghia 66-74, Type 2 66-74, Type 3 63-71  
(Ref. P/N: 113 127 521A)



## FUEL HOSE

Heavy duty reinforced fuel hose. Same High Quality Hose as used in all EMPI Carburetor Kits. Available in 1/4" and 5/16" and sold in 3 lengths. We also offer stock style braided fabric fuel hose in 3.5mm I.D. and 5mm I.D.

**3525** 1/4" x 5' Length, Skin packed  
**3526** 1/4" x 25' Length, Boxed  
**3527** 1/4" x 50' Length, Boxed

**3529** 5/16" x 5' Length, Skin packed  
**3530** 5/16" x 25' Length, Boxed  
**3531** 5/16" x 50' Length, Boxed

**98-0122-B** OE Style Braided Fabric Fuel Hose, 3.5mm I.D. x 10 Meter, Bulk  
(Ref P/N: N20-353-1)

**98-0123-B** OE Style Braided Fabric Fuel Hose, 5mm I.D. x 10 Meter, Bulk  
(Ref P/N: N20-355-1)



## BRAIDED STAINLESS LINE

Our 1/4" (#4) Braided Stainless Line provides good looks and reliability. Sold in 3 lengths.

**8810** 1/4" x 5' Length, Skin Packed  
**8811** 1/4" x 10' Length, Skin Packed  
**8812** 1/4" x 25' Length, Boxed  
**9224** Hose Clamp, 1/4" & 5/16", Pack of 4



## STOCK FUEL PUMPS AND FUEL PUMP SPACER

Replacement Fuel Pumps.

(See hard parts section in back of catalog for push rods, gaskets, fuel hose, etc.)



98-1271



98-1270  
(Chrome)

**98-1271** Fuel Pump, 1200-1600cc Type 1/2/3 w/Generator  
(Bulk P/N: 113 127 025BCD)

**98-1270** Fuel Pump, **Chrome**, 1200-1600cc Type 1/2/3 w/Generator  
(Bulk P/N: 113 127 025BCH)



98-2079



98-2080

**98-2079** Fuel Pump, 1200-1600cc Type 1 w/Alternator  
(Bulk P/N: 113 127 025G)

**98-2080** Fuel Pump Spacer, Each  
(Bulk P/N: 113 127 303)



98-1181-B



98-1180-B  
**NEW!**

**98-1181-B** Push Rod, Fuel Pump w/Alt, (100mm), Type 1 73-74,  
Ghia 73-74, Each  
(Ref. P/N: 113 127 307A) Used with Alternator / Angled Pump (98-2079)

**98-1180-B** **NEW!** Push Rod, Fuel Pump, (108mm), Type 1 61-73,  
Type 2 61-71, Type 3 62-67, Ghia 61-73, Each  
(Ref. P/N: 113 127 307) Used with Generator / Straight Pump (98-1270 / 98-1271)



98-1182-B



98-1183-B

**98-1182-B** Gasket, Fuel Pump Flange Mounting, Type 1 61-74,  
Ghia 61-74, Type 2 61-71, Type 3 64-67, Each  
(Ref. P/N: 113 127 311)

**98-1183-B** Gasket, Fuel Pump Mounting, Type 1 61-74, Ghia 61-74,  
Type 2, 61-71, Type 3 64-67, Each  
(Ref. P/N: 113 127 313)



31-3011

## FUEL PUMP BLOCK-OFF / MOUNT

Two versions available to suit your specific needs. Block off with threaded breather boss. Block off in high tech polished Billet aluminum. All include mounting gasket.

**9094** Fuel Pump Block-Off w/Boss

**31-3011** **Billet Aluminum** Fuel Pump Block-Off



9094



31-3010

## ELECTRIC FUEL PUMP MOUNT KIT

Allows for the installation of EMPI or Facet electric fuel pumps in the stock pump location. Hardware and gasket included.

**31-3010** Electric Fuel Pump Mount Kit



# INTAKE - ACCESSORIES, JETS & MISC.

## EMPI SOLID STATE ELECTRIC FUEL PUMPS

Solid state circuitry for reliability and made by EMPI with a H.D. metal case so it will work right and last a long time. Available for standard carburetor use in the 1.5 to 4.0 PSI range or also for high performance use in a 4.0 to 8.0 PSI range. (It is highly recommended that a fuel pressure regulator be used with any of these pumps on a carburetor application).

41-2500-8	EMPI Fuel Pump Only, 1.5 - 4.0 PSI, Boxed
41-2510-8	EMPI Fuel Pump, 1.5 - 4.0 PSI, w/Fittings & Clamps, Boxed
41-2500	EMPI Fuel Pump, 1.5 - 4.0 PSI, w/Fittings & Clamps, Skinpacked

41-2520-8	EMPI Fuel Pump Only, 4.0 - 8.0 PSI, Boxed
41-2530-8	EMPI Fuel Pump, 4.0 - 8.0 PSI, w/Fittings & Clamps, Boxed
41-2520	EMPI Fuel Pump, 4.0 - 8.0 PSI, w/Fittings & Clamps, Skinpacked

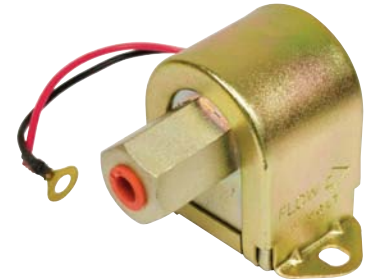

## FACET SOLID STATE ELECTRIC FUEL PUMP

Solid State reliability pumping 30 G.P.H @ 2 to 4 P.S.I. Use with gas or alcohol. (It is highly recommended that a fuel pressure regulator be used with any of these pumps on a carburetor application).

41-2000	Fuel Pump Only, Skinpacked
41-2000-8	Fuel Pump Only, Boxed

41-2010	Pump w/Fittings & Clamps, Skinpacked
41-2010-8	Pump w/Fittings & Clamps, Boxed



## IN-LINE FUEL PUMP W/FILTER

This 12V in-line fuel pump provides a quiet 30 GPH fuel flow at 2-4 PSI and requires no pressure regulator. 5/16" inlet and outlet. Fuel filter and mounting hardware included. Can be used with 6 Volts.

41-2604	In-Line Fuel Pump w/Filter
---------	----------------------------

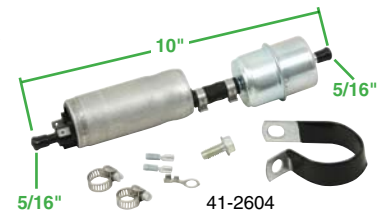

## FUEL PRESSURE REGULATOR

Adjust fuel pressure to your carb. to prevent needle & seat damage on performance carbs. Regulators are adjustable from 0 to full wide open flow. You should use a gauge to check the pressure. **Lead Free Gasoline Only, Maximum 7 P.S.I.**

9091	Chrome Fuel Pressure Regulator w/Chrome Bracket
9102	Chrome Fuel Pressure Regulator

9090	Chrome Mounting Bracket for P/N: 9102
------	---------------------------------------

9097	5/16" Fuel Fitting for P/N: 9102, Pair
9103	1/4" Fuel Fitting for P/N: 9102, Pair

9224	Hose Clamp, 1/4" & 5/16", Pack of 4
------	-------------------------------------



9102

9090

9097

9224



## STOCK & EXTRA CAPACITY GAS TANKS

Replace that rusted, dirty old gas tank with a new standard or Extra-Capacity tank. Fits Type 1.



95-2001-B



95-2000-B



95-2004-B

## TYPE 1 TANKS

**95-2001-B** Gas Tank, 60-67 Includes Gas Tank Outlet Pipe Kit. [Must use Gas Cap 95-2005-B.](#)

(Ref. P/N: 113 201 075AB)

**95-2000-B** Gas Tank, 68-74 Includes Gas Tank Outlet Pipe Kit.

(Ref. P/N: 113 201 075AD)

**95-2004-B** Extra Capacity 12 1/2 Gal. Gas Tank, 60-67 Includes Gas Tank Outlet Pipe Kit. [Must use Gas Cap 95-2005-B.](#)

(Ref. P/N: 113 201 075/16)



**NEW!** 95-2002-B



95-2003-B

## SUPER BEETLE TANKS

**95-2002-B** **NEW!** Gas Tank, All Super Beetle (71-74) (Ref. P/N: 133 201 075F)

**95-2003-B** Gas Tank, All Super Beetle (75-79) (Ref. P/N: 133 201 075G)

## TYPE 2 GAS TANKS

**95-2008-B** Gas Tank, Type 2, 55-67 (Ref P/N: 211 201 055B)

**95-2011-B** **NEW!** Gas Tank, Type 2, 68-72 Includes Sending Unit, Gas Tank Outlet Pipe Kit and Caps for Vent Lines. Instructions Included.

*Uses Special Sending Unit Included with Tank*

**95-2013-B** **NEW!** Gas Tank, Type 2, 73-74 Includes Gas Tank Outlet Pipe Kit and Caps for Vent Lines. Utilizes stock sending unit. Instructions Included.

*Uses Stock Sending Unit*

(Ref P/N: 211 201 075L)

**95-2012-B** **NEW!** Gas Tank, Type 2, 75-79 Includes Sending Unit, Gas Tank Outlet Pipe Kit and Cap for Vent Lines. Instructions Included.

*Uses Special Sending Unit Included with Tank*



95-2008-B



**NEW!** 95-2011-B



**NEW!** 95-2013-B



**NEW!** 95-2012-B



# INTAKE - ACCESSORIES, JETS & MISC.

## **GAS TANK OUTLET PIPE KIT**

**95-2006** Gas Tank Outlet Pipe Kit, Type 1, 60-74  
(Bulk P/N: 113 298 221)



## **GAS CAPS**

**95-2005** Gas Cap for P/N: 95-2001-B & 95-2004-B Tanks  
(Bulk P/N: 95-2005-B)



95-2005



98-2104

**98-2104** Gas Cap, Type 1, 68-71  
(Bulk P/N: 113 201 551A)

**98-2114** **NEW!** Locking Gas Cap, Type 1, 68-71  
(Bulk P/N: 113 201 551AL)



98-2114 **NEW!**

**98-2105** Locking Gas Cap, Type 1, 72-79  
(Bulk P/N: 321 201 551H)



98-2105

## **FUEL GAUGE & TANK SENDERS**

Stock-style fuel gauge and sending units.

**98-2019** Fuel Gauge, Type 1, 62-67  
(Bulk P/N: 113 919 029)



98-2019

**98-2020** Fuel Tank Sending Unit, Manual Sender, Type 1, 62-67  
(Bulk P/N: 113 919 049C)



98-2020

**98-2021** Fuel Tank Sending Unit, Electric Sender, Type 1,  
Standard Beetle 68 & Later  
(Bulk P/N: 113 919 049D)

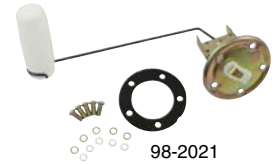

98-2021

**98-2022** Fuel Tank Sending Unit, Super Beetle, All  
(Bulk P/N: 113 919 051F)

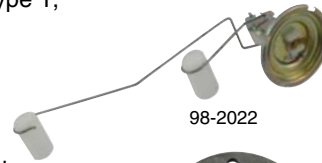

98-2022

**98-2037** Fuel Tank Sender Gasket, Exc. Super Beetle  
(Bulk P/N: 113 919 133)



98-2037

**98-9194-B** Fuel Gauge Sender, Type 2 55-66, Each  
(Ref. P/N: 271 919 051B)



98-9194-B

**98-9193-B** **NEW!** Fuel Tank Sending Unit, Stock Replacement, Each  
Type 2, 1973 to 1979  
(Ref. P/N: 211 919 051A)



98-9193-B **NEW!**

**Can be used with EMPI Fuel Tank 95-2013-B.**

**Supplied with EMPI Fuel Tank 95-2011-B.**

**Will not fit EMPI Fuel Tank 95-2012-B.**

## **FUEL TANK SCREEN**

Original Equipment Style Fuel Tank Screen. Fits All VW Fuel Tanks 50-74.

**98-2109** Fuel Tank Screen, All 50-74, Each  
(Bulk P/N: 111 209 147A)



98-2109

## EMPI EPC CARBS

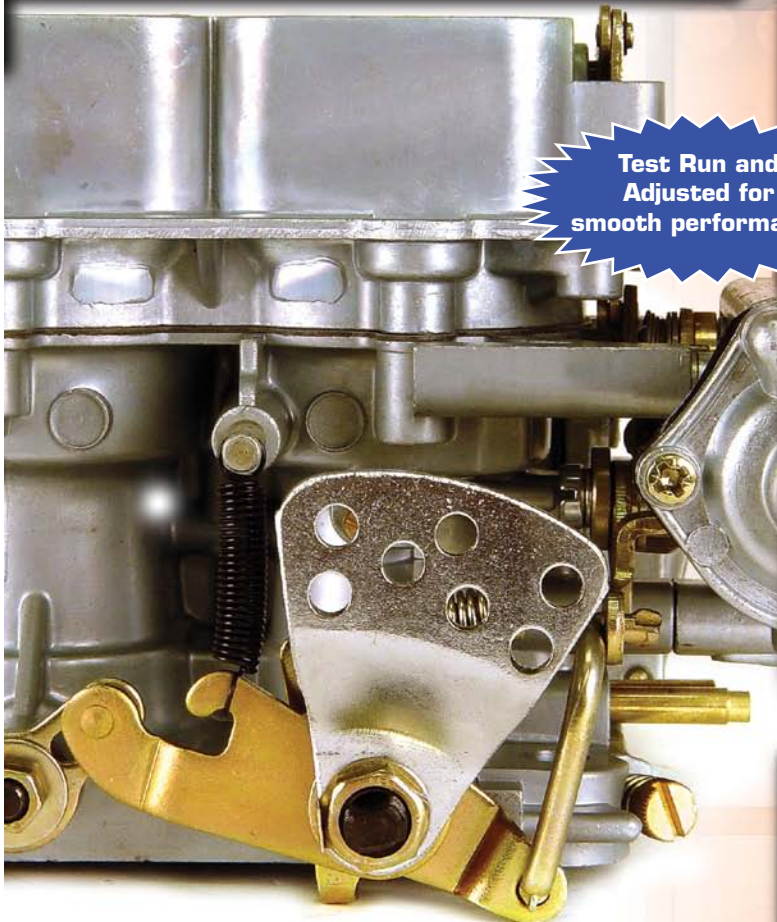

Test Run and  
Adjusted for  
smooth performance

EPC 32/36A



EPC 32/36E



EPC 32/36M



EPC 38E



We at EMPI are proud to offer you the finest Carburetor and Carburetor Conversion Kits in the market today. All Carburetors are of EMPI origin. The EPC 32/36 is a Progressive Carburetor. The Progressive features of "Primary" and "Secondary" allow for a very controlled driving experience. The EPC 38 is a "Synchronous" type Carburetor. This means that both barrels are opening simultaneously. This usually allows for more torque (ie. throttle response and overall horsepower) due to more CFM of the Carburetor. To truly realize horsepower gains, additional performance improvements must be done to the engine. EMPI Carburetor numbers are followed by certain letters. The meaning of each is as follows. E = Electric Choke, A = Water Choke, M = Manual Choke, F also has an Electric Choke.





# INTAKE - CARB. KITS & COMPONENTS

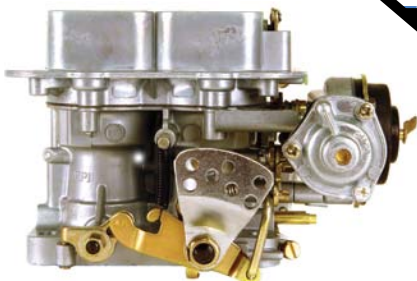

**44-1551-1  
Electric Choke**

## EMPI EPC 32/36E

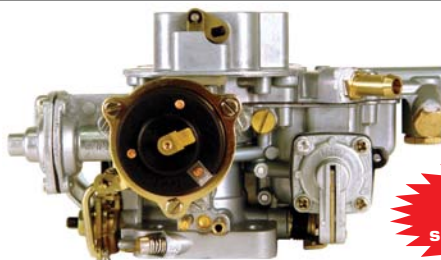

Test Run and  
Adjusted for  
smooth performance



**44-1551-2  
Manual Choke**

## EMPI EPC 32/36M



Test Run and  
Adjusted for  
smooth performance



**44-1017-1  
Electric Choke**

## EMPI EPC 32/36E



Test Run and  
Adjusted for  
smooth performance



**44-1017-2  
Water Choke  
Toyota Style**

## EMPI EPC 32/36A

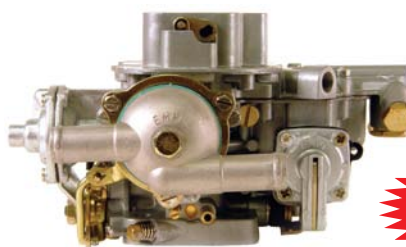

Test Run and  
Adjusted for  
smooth performance

## [ EMPI EPC 32/36A ]



**44-1017-3**  
**Water Choke**  
**Suzuki Style**



Test Run and  
Adjusted for  
smooth performance

## [ EMPI EPC 32/36M ]



**44-1017-4**  
**Manual Choke**



Test Run and  
Adjusted for  
smooth performance

## [ EMPI EPC 38E ]

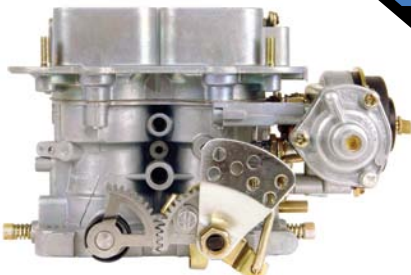

**44-1005-1**  
**Electric Choke**



Test Run and  
Adjusted for  
smooth performance

## [ EMPI EPC 38E ]



**44-1006-1**  
**Electric Choke**

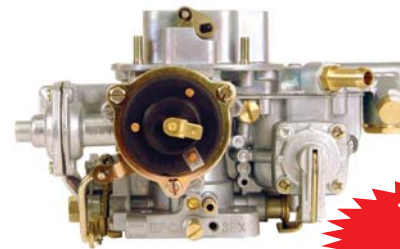

Test Run and  
Adjusted for  
smooth performance



# INTAKE - CARB. KITS & COMPONENTS

We at EMPI are proud to offer you the finest Carburetor and Carburetor Conversion Kits in the market today. All Carburetors are of EMPI origin. The EPC 32/36 is a Progressive Carburetor. The Progressive features of "Primary" and "Secondary" allow for a very controlled driving experience. The EPC 38 is a "Synchronous" type Carburetor. This means that both barrels are opening simultaneously. This usually allows for more torque (ie. throttle response and overall horsepower) due to more CFM of the Carburetor. To truly realize horsepower gains, additional performance improvements must be done to the engine. EMPI Carburetor numbers are followed by certain letters. The meaning of each is as follows. **E** = Electric Choke, **A** = Water Choke, **M** = Manual Choke, **F** also has an Electric Choke.

## EMPI Performance Carburetor for Jeep Vehicles

We offer two different EPC Carburetors. The EPC 32/36 Progressive Kits are designed for fuel economy and low-end (RPM) performance. The EPC 38 Kits are for people who are looking for maximum performance. All EMPI Kits come complete with all necessary installation hardware and instructions.

Test Run and Adjusted for smooth performance

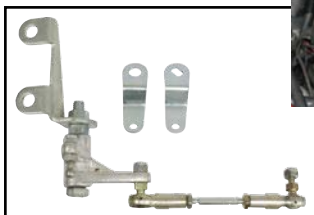

Linkage Parts for Automatic Transmission



EMPI Carburetor Kit with Air Cleaner



\* Jet Kit Now Included in 47-1551 & 47-1551-5 Kits  
 1 ea. 43-5330  
 1 ea. 43-5331  
 1 ea. 43-5506

These will help with richer jetting. Move Main Jets between barrels and go richer with these additional jets if needed

47-1551 (Jeep)



### EPC 32/36 Kits for Jeep (32/36 Progressive Carb)

Std. Kit No.	Kit No. W/ Press. Reg.	Year	Application	Original Carburetor	New Carb.	Replacement Air Filter
47-1553	47-1553-5	50-71	CJ's w/134 CI 4 Cyl. (2.1L) (F, SF, 4J)	Carter 1-BBL C-1 YF	32/36 Manual	9025
47-1551*+	47-1551-5*+	76-90	CJ's & Cherokee w/258 CI 6 Cyl. (4.2L) (C,M,T)	Carter 2-BBL C-2BBD	32/36 Electric	9025
47-1491	47-1491-5	80-83	CJ's, Cherokee w/151CI 4 Cyl. (2.5L) (B)	Roch. 2-BBL R2 E2SE	32/36 Electric	8806
47-1552+	47-1552-5+	83-88	CJ's & Cherokee w/151 CI 4 Cyl. (2.5L) (U)	Carter 1-BBL C-1 YFA	32/36 Electric	8806
47-1550+	47-1550-5+	74-78	CJ's w/258 CI 6 Cyl. (4.2L)	Carter 1-BBL C-1 YFA	32/36 Electric	9025
47-1550+	47-1550-5+	72-78	CJ's & Scrambler w/232 CI	Carter 1-BBL YF/YFA	32/36 Electric	9025

+ Linkage parts for Automatic Transmissions supplied in these kits

Jeep® and its associated models are registered trademarks of Chrysler LLC®

# INTAKE - CARB. KITS & COMPONENTS



EMPI now offers Jeep kits with Fuel Pressure Regulators. These kits include the fuel pressure regulator, chrome bracket, brass fittings and mounting screws. To have the regulator included in the kit, make sure to order the kit numbers ending in (-5).

47-1559  
(Jeep)



## EPC 38 Kits for Jeep (38 Synchronous Carb)

Std. Kit No.	Kit No. W/ Press. Reg.	Year	Application	Original Carburetor	New Carb.	Replacement Air Filter
47-1490	47-1490-5	84-86	Cherokee w/173 CI 6 Cyl. (2.8L) (W)	Roch. 2-BBL R2 E2SE	38 Electric	Use Orig. A/C
47-1558	47-1558-5	74-78	CJ's w/258 CI 6 Cyl. (4.2L)	Carter 1-BBL C-1 YF	38 Electric	9025
47-1559	47-1559-5	76-90	CJ's & Cherokee w/258 CI 6 Cyl. (4.2L) (C, M, T)	Carter 2-BBL C-2 BBD	38 Electric	9025

Jeep® and its associated models are registered trademarks of Chrysler LLC®

Test Run and Adjusted for smooth performance

47-1204  
(BMW)



## BMW

EMPI #	Year	Application	Carburetor	Carb. to Manifold	Linkage	Air Filter
47-1909	64-71	1600, 1800, 2000cc w/ 1-BBL Solex	EPC 34X (Manual Choke) (-IC)	DM	X	Use Orig. A/C
47-1909	68-6/72	2002 1970cc w/ 1-BBL Solex	EPC 34X (Manual Choke) (-IC)	DM	X	Use Orig. A/C
47-1204	68-76	2002 1970cc w/ 2-BBL Solex	EPC 32/36A (-IC)	DM	S	8806
47-1604	68-76	2002 1970cc w/ 2-BBL Solex	EPC 38E	DM	S	8806

**Carb. / Manifold:** DM = Direct Mount    MAN = Supplied with Manifold    ADPT = Adapter    IK = Installation Kit  
**Air Filter:** X = Use Original    N/S = Not Supplied    (-IC) = Carb. Supplied w/Electric Idle Cut-Off Solenoid  
**Linkage:** X = Use Original    S = Supplied    X1 = Use Throttle Arm from Original Carb.    X3 = Kit Supplied; A/T use Throttle Arm from Original Carb.  
 X2 = A/T may require Linkage Modification



# INTAKE - CARB. KITS & COMPONENTS

## Chevrolet

Std. Kit No.	Year	Application	Carburetor	Carb. to Manifold	Linkage	Air Filter
47-1453	1979 1979+	Chevette Holley 5200 & 5210 Monza, Vega w/ Holley 5200	EPC 32/36F EPC 32/36F	DM DM	X2 X2	Use Orig. A/C Use Orig. A/C
47-1696	83-88	S10, S15 Blazer 1.9, 2.0L, Hitachi	EPC 32/36E	ADPT	S	9025
47-1491	85- 1979+	S10 Pick-Up 2.5L, 4 Cyl. w/Rochester 2SE Monza, Vega w/ Holley 5200	EPC 32/36E EPC 32/36E	ADPT ADPT	S X2	8806 8806
47-1490	83-88	S10, Blazer V6, Rochester 2SE	EPC 38E	ADPT	S	Use Orig. A/C
47-1741	85-88	Nova 4 Cyl. 1.6 4ALC, 4AGE	EPC 32/36E	ADPT	S	9025

## Chevrolet - Japan

Std. Kit No.	Year	Application	Carburetor	Carb. to Manifold	Linkage	Air Filter
47-1657	72-82	Luv, 1817cc Series 1-6, 8-12, 1817cc	EPC 32/36M	ADPT	S	9025
47-1662	72-82	Luv, 1817cc Series 1-6, 8-12, 1817cc	EPC 32/36E	ADPT	S	9025
47-2662	72-82	Luv, 1817cc Series 1-6, 8-12, 1817cc (Hi Perf. Conversion)	EPC 38E	ADPT	S	9025
47-1602	71-82	Luv, 1800cc w/ Hitachi Carb	EPC 32/36E	ADPT	S	9025



## Chrysler

EMPI #	Year	Application	Carburetor	Carb. to Manifold	Linkage	Air Filter
47-1611	76-80	Arrow 1600cc	EPC 32/36F	ADPT	X3	9032
47-1611	76-79	Arrow 2000cc	EPC 32/36F	ADPT	X3	9032
47-1611	76-80	Arrow 2600cc	EPC 32/36F	ADPT	X3	9032
47-1611	78-79	Challenger 1600cc	EPC 32/36F	ADPT	X3	9032
47-1611	78-83	Challenger 2600cc	EPC 32/36F	ADPT	X3	9032
47-1612	79-83	Champ (FWD) 1400cc	EPC 32/36F	ADPT	S	9032
47-1612	79-83	Champ (FWD) 1600cc	EPC 32/36F	ADPT	S	9032
47-1611	78-80	Colt (RWD) 1600cc	EPC 32/36F	ADPT	X3	9032
47-1611	78-79	Colt (RWD) 2000cc	EPC 32/36F	ADPT	X3	9032
47-1611	78-80	Colt (RWD) 2600cc	EPC 32/36F	ADPT	X3	9032
47-1612	79-83	Colt (FWD) 1400, 1600cc	EPC 32/36F	ADPT	S	9032
47-1611	78-79	Sapporo 1600cc	EPC 32/36F	ADPT	X3	9032
47-1611	78-83	Sapporo 2600cc	EPC 32/36F	ADPT	X3	9032

Carb. / Manifold: **DM** = Direct Mount    **MAN** = Supplied with Manifold    **ADPT** = Adapter    **IK** = Installation Kit

Air Filter: **X** = Use Original    **N/S** = Not Supplied    **(-IC)** = Carb. Supplied w/Electric Idle Cut-Off Solenoid

Linkage: **X** = Use Original    **S** = Supplied    **X1** = Use Throttle Arm from Original Carb.    **X3** = Kit Supplied; A/T use Throttle Arm from Original Carb.

**X2** = A/T may require Linkage Modification

# INTAKE - CARB. KITS & COMPONENTS



## Chrysler continued

EMPI #	Year	Application	Carburetor	Carb. to Manifold	Linkage	Air Filter
47-1611	79-84	D-50, Ram-50 Pick-Up 2000, 2600cc	EPC 32/36F	ADPT	X3	9032
47-1610	79-89	D-50, Ram-50 Pick-Up 2000, 2600cc (w/ Standard Transmission)	EPC 32/36E	ADPT	X3	9025
47-2611	79-84	D-50, Ram-50 Pick-Up 2000, 2600cc (Hi Perf. Conversion)	EPC 38E	ADPT	X3	9025
47-1611	79-84	J-4 P/U 2000, 2600cc	EPC 32/36F	ADPT	X3	9032
47-1610	79-89	J-4 P/U 2000, 2600cc (w/ Standard Trans.)	EPC 32/36E	ADPT	X3	9025
47-2611	79-84	J-4 P/U 2000, 2600cc (Hi Perf. Conversion)	EPC 38E	ADPT	X3	9025
47-1453	78-80	Omni, Horizon, Charger, K Car, Rampage 1.7, 2.2L w/ Holley 5200 Series	EPC 32/36F	DM	X	Use Orig. A/C

## Ford

EMPI #	Year	Application	Carburetor	Carb. to Manifold	Linkage	Air Filter
47-1657	72-82	Courier 1800 Pick-Up 1796cc	EPC 32/36M	ADPT	S	9025
47-1662	72-82	Courier 1800 Pick-Up 1796cc	EPC 32/36E	ADPT	S	9025
47-2662	72-82	Courier 1800 Pick-Up 1796cc (Hi Perf. Conversion)	EPC 38E	ADPT	S	9025
47-1552		Ranger 2300cc (w/Carter 1-Barrel Carb.)	EPC 32/36E	ADPT	S	8806

**Test Run and Adjusted for smooth performance**

47-1727 (Honda)



## Honda

EMPI #	Year	Application	Carburetor	Carb. to Manifold	Linkage	Air Filter
47-1624	73-83	Civic Non-CVCC 1200, 1300cc-1500 8 Valve	EPC 32/36E (-IC)	ADPT	S	8806
47-1727	84-85	Accord 1800cc	EPC 32/36E (-IC)	ADPT	S	8806
47-1727	84-85	Prelude 1800cc	EPC 32/36E (-IC)	ADPT	S	8806

**Carb. / Manifold:** DM = Direct Mount    MAN = Supplied with Manifold    ADPT = Adapter    IK = Installation Kit  
**Air Filter:** X = Use Original    N/S = Not Supplied    (-IC) = Carb. Supplied w/Electric Idle Cut-Off Solenoid  
**Linkage:** X = Use Original    S = Supplied    X1 = Use Throttle Arm from Original Carb.    X3 = Kit Supplied; A/T use Throttle Arm from Original Carb.  
X2 = A/T may require Linkage Modification



# INTAKE - CARB. KITS & COMPONENTS

47-1697  
(Isuzu Pick-up)



( Same Hardware Kit )  
Different Carb.

Test Run and  
Adjusted for  
smooth performance

47-2697  
(Isuzu Pick-up)



## Isuzu

EMPI #	Year	Application	Carburetor	Carb. to Manifold	Linkage	Air Filter
47-1662	79-83	I-Mark 1817cc	EPC 32/36E	ADPT	S	9025
47-1662	79-83	Pick-Up 1817cc	EPC 32/36E	ADPT	S	9025
47-2662	79-83	Pick-Up 1817cc (Hi Perf. Conversion)	EPC 38E	ADPT	S	9025
47-1696	83-87	Pick-Up 1949cc	EPC 32/36E	ADPT	S	9025
47-1697	86-	Pick-Up 2300cc	EPC 32/36E	ADPT	S	9025
47-2697	86-	Pick-Up 2300cc (Hi Perf. Conversion)	EPC 38E	ADPT	S	9025
47-1696	84-85	Trooper 1949cc	EPC 32/36E	ADPT	S	9025
47-1697	86-87	Trooper 2.3 Manual Trans.	EPC 32/36E	ADPT	S	9025
47-2697	86-87	Trooper 2.3 Manual Trans. (Hi Perf. Conv.)	EPC 38E	ADPT	S	9025

47-1675  
(Mazda Pick-Up)



( Same Hardware Kit )  
Different Carb.

47-2675  
(Mazda Pick-Up)



Test Run and  
Adjusted for  
smooth performance



## Mazda

EMPI #	Year	Application	Carburetor	Carb. to Manifold	Linkage	Air Filter
47-1602	72-78	B1800 1.6, 1.8	EPC 32/36E	ADPT	S	9025
47-1662	77-78	B1600, B1800 Pick-Up 1796cc, 1.6, 1.8	EPC 32/36E	ADPT	S	9025
47-2662	77-78	B1600, B1800 Pick-Up 1796cc (Hi Perf. Conv.), 1.6, 1.8	EPC 38E	ADPT	S	9025
47-2662	79-82	626 (RWD) w/ 2	EPC 38E	ADPT	S	9025
47-2662	83-85	626 w/ 2	EPC 38E	ADPT	S	9025
47-1675	86-93	B2000 Pick-Up 1970cc (Use w/Stock Cable Linkage)	EPC 32/36E	ADPT	S	9025
47-2675	86-93	B2000 Pick-Up 1970cc (Hi Perf. Conv.)	EPC 38E	ADPT	S	9025
47-1675	87-91	B2200 Pick-Up 2200cc	EPC 32/36E	ADPT	S	9025
47-2675	87-91	B2200 Pick-Up 2200cc (Hi Perf. Conv.)	EPC 38E	ADPT	S	9025
47-1624	76-80	GLC, Mizer (RWD)	EPC 32/36E	ADPT	S	9025

**Carb. / Manifold:** DM = Direct Mount    MAN = Supplied with Manifold    ADPT = Adapter    IK = Installation Kit

**Air Filter:** X = Use Original    N/S = Not Supplied    (-IC) = Carb. Supplied w/Electric Idle Cut-Off Solenoid

**Linkage:** X = Use Original    S = Supplied    X1 = Use Throttle Arm from Original Carb.    X3 = Kit Supplied; A/T use Throttle Arm from Original Carb.

X2 = A/T may require Linkage Modification

# INTAKE - CARB. KITS & COMPONENTS



## Mitsubishi

EMPI #	Year	Application	Carburetor	Carb. to Manifold	Linkage	Air Filter
47-1611		Montero w/Std. Trans., 2.6L, 2.0L	EPC 32/36F	ADPT	X3	9032
47-1610		Montero w/Std. Trans., 2.6L, 2.0L	EPC 32/36E	ADPT	X3	9025
47-2611		Montero w/Std. Trans., 2.6L, 2.0L (Hi Perf. Conv.)	EPC 38E	ADPT	X3	9025
47-1614		*Montero w/ Auto Trans., 2.6L, 2.0L	EPC 32/36F	ADPT	S	9032

\*(1987 & Later w/Auto Trans. may require extensive throttle linkage modifications to operate the passing gear kick down)



## Nissan

EMPI #	Year	Application	Carburetor	Carb. to Manifold	Linkage	Air Filter
47-1657	68-73	510 L16 1595cc	EPC 32/36M	ADPT	S	9025
47-1662	68-73	510 L16 1595cc	EPC 32/36E	ADPT	S	9025
47-2662	68-73	510 L16 1595cc (Hi Perf. Conversion)	EPC 38E	ADPT	S	9025
47-1657	78-79	510 L20B 1952cc	EPC 32/36M	ADPT	S	9025
47-1662	78-79	510 L20B 1952cc	EPC 32/36E	ADPT	S	9025
47-2662	78-79	510 L20B 1952cc (Hi Perf. Conversion)	EPC 38E	ADPT	S	9025
47-1657	80-81	510 Z20S 1952cc	EPC 32/36M	ADPT	S	9025
47-1662	80-81	510 Z20S 1952cc	EPC 32/36E	ADPT	S	9025
47-2662	80-81	510 Z20S 1952cc (Hi Perf. Conversion)	EPC 38E	ADPT	S	9025
47-1657	1973	610 L18 1770cc	EPC 32/36M	ADPT	S	9025
47-1662	1973	610 L18 1770cc	EPC 32/36E	ADPT	S	9025
47-2662	1973	610 L18 1770cc (Hi Perf. Conversion)	EPC 38E	ADPT	S	9025

Carb. / Manifold: DM = Direct Mount

MAN = Supplied with Manifold

ADPT = Adapter

IK = Installation Kit

Air Filter: X = Use Original

N/S = Not Supplied

(-IC) = Carb. Supplied w/Electric Idle Cut-Off Solenoid

Linkage: X = Use Original

S = Supplied

X1 = Use Throttle Arm from Original Carb.





# INTAKE - CARB. KITS & COMPONENTS

## Nissan continued

EMPI #	Year	Application	Carburetor	Carb. to Manifold	Linkage	Air Filter
47-1657	74-76	610 L20B 1952cc	EPC 32/36M	ADPT	S	9025
47-1662	74-76	610 L20B 1952cc	EPC 32/36E	ADPT	S	9025
47-2662	74-76	610 L20B 1952cc (Hi Perf. Conversion)	EPC 38E	ADPT	S	9025
47-1657	1974	710 L18 1770cc	EPC 32/36M	ADPT	S	9025
47-1662	1974	710 L18 1770cc	EPC 32/36E	ADPT	S	9025
47-2662	1974	710 L18 1770cc (Hi Perf. Conversion)	EPC 38E	ADPT	S	9025
47-1657	75-77	710 L20B 1952cc	EPC 32/36M	ADPT	S	9025
47-1662	75-77	710 L20B 1952cc	EPC 32/36E	ADPT	S	9025
47-2662	75-77	710 L20B 1952cc (Hi Perf. Conversion)	EPC 38E	ADPT	S	9025
47-1657	77-79	200SX L20 1952cc	EPC 32/36M	ADPT	S	9025
47-1662	77-79	200SX L20 1952cc	EPC 32/36E	ADPT	S	9025
47-2662	77-79	200SX L20 1952cc (Hi Perf. Conversion)	EPC 38E	ADPT	S	9025
47-1657	69-72	521 Pick-Up L16 1596cc	EPC 32/36M	ADPT	S	9025
47-1662	69-72	521 Pick-Up L16 1596cc	EPC 32/36E	ADPT	S	9025
47-2662	69-72	521 Pick-Up L16 1596cc (Hi Perf. Conv.)	EPC 38E	ADPT	S	9025
47-1657	1974	620 Pick-Up L18 1770cc	EPC 32/36M	ADPT	S	9025
47-1662	1974	620 Pick-Up L18 1770cc	EPC 32/36E	ADPT	S	9025
47-2662	1974	620 Pick-Up L18 1770cc (Hi Perf. Conv.)	EPC 38E	ADPT	S	9025
47-1657	75-79	620 Pick-Up L20B 1952cc	EPC 32/36M	ADPT	S	9025
47-1662	75-79	620 Pick-Up L20B 1952cc	EPC 32/36E	ADPT	S	9025
47-2662	75-79	620 Pick-Up L20B 1952cc (Hi Perf. Con.)	EPC 38E	ADPT	S	9025
47-1657	1980	720 Pick-Up L20B 1952cc	EPC 32/36M	ADPT	S	9025
47-1662	1980	720 Pick-Up L20B 1952cc	EPC 32/36E	ADPT	S	9025
47-2662	1980	720 Pick-Up L20B 1952cc (Hi Perf. Conv.)	EPC 38E	ADPT	S	9025
47-1657	81-82	720 Pick-Up Z22 2187cc	EPC 32/36M	ADPT	S	9025
47-1662	81-82	720 Pick-Up Z22 2187cc	EPC 32/36E	ADPT	S	9025
47-2662	81-82	720 Pick-Up Z22 2187cc (Hi Perf. Conv.)	EPC 38E	ADPT	S	9025
47-1646	83-85	Pick-Up Z24 2389cc	EPC 32/36E	ADPT	S	9025
47-2646	83-85	Pick-Up Z24 2389cc (Hi Perf. Conversion)	EPC 38E	ADPT	S	9025

## Oldsmobile - Pontiac

EMPI #	Year	Application	Carburetor	Carb. to Manifold	Linkage	Air Filter
47-1453		140, 150cid Models w/Holley 5210	EPC 32/36F	DM	X	Use Orig. A/C
47-1491		4 Cyl. & V6 w/Rochester 2SE	EPC 32/36E	ADPT	S	8806

## Renault

EMPI #	Year	Application	Carburetor	Carb. to Manifold	Linkage	Air Filter
47-1453	76-83	R-5 "Le Car" 1289, 1397cc	EPC 32/36F	DM	X1	Use Orig. A/C
47-1453	71-79	R12, 15, 17, w/WEBER DIR, DARA	EPC 32/36F	DM	X1	Use Orig. A/C

## SAAB

EMPI #	Year	Application	Carburetor	Carb. to Manifold	Linkage	Air Filter
47-1909	67-74	95, 96 Sonnet w/Ford 1 BBL	EPC 34X (-IC)	DM	X	Use Orig. A/C

**Carb. / Manifold:** DM = Direct Mount    MAN = Supplied with Manifold    ADPT = Adapter    IK = Installation Kit  
**Air Filter:** X = Use Original    N/S = Not Supplied    (-IC) = Carb. Supplied w/Electric Idle Cut-Off Solenoid  
**Linkage:** X = Use Original    S = Supplied    X1 = Use Throttle Arm from Original Carb.    X3 = Kit Supplied; A/T use Throttle Arm from Original Carb.  
X2 = A/T may require Linkage Modification

# INTAKE - CARB. KITS & COMPONENTS

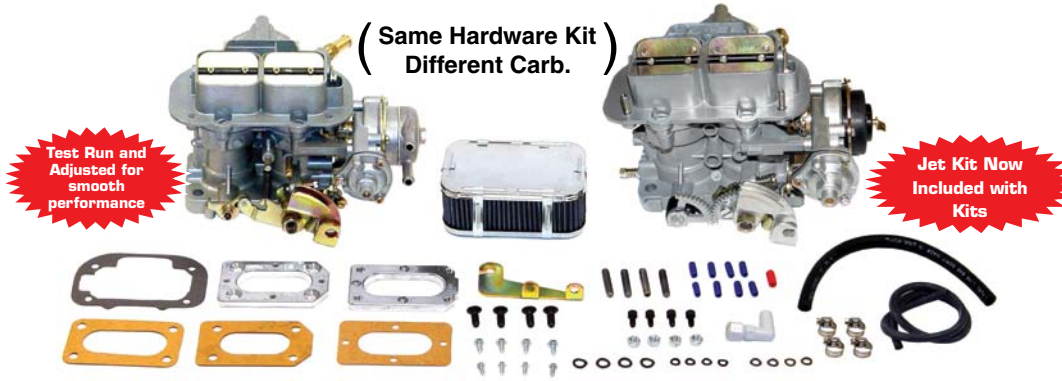

These will help with richer jetting. Move Main Jets between barrels and go richer with these additional jets if needed

\* Now included in Suzuki Kits

- 1 ea. 43-5329
- 1 ea. 43-5331
- 1 ea. 43-5504

## Suzuki

EMPI #	Year	Application	Carburetor	Carb. to Manifold	Linkage	Air Filter
47-1600*	86-89	Samurai 1342cc	EPC 32/36A	ADPT	S	Use Orig. A/C
47-1601*	86-89	Samurai 1342cc	EPC 32/36A	ADPT	S	9025
47-1602*	86-89	Samurai 1342cc	EPC 32/36E	ADPT	S	9025
47-1603*	86-89	Samurai 1342cc (Hi Perf. Conversion)	EPC 38E	ADPT	S	9025



## Toyota

EMPI #	Year	Application	Carburetor	Carb. to Manifold	Linkage	Air Filter
47-1657	All	Corolla/Tercel w/ 3KC - Manual Choke	EPC 32/36E	ADPT	S	9025
47-1662	72-73	Carina 2TC 1588cc	EPC 32/36E	ADPT	S	9025
	All	Corolla/Tercel w/ 3KC	EPC 32/36E	ADPT	S	9025
47-1752	75-80	Celica/Corona 20R 2189cc	EPC 32/36A	ADPT	S	9025
47-1746	81-84	Celica 22R 2366cc	EPC 32/36E	ADPT	S	9025
47-1662	71-74	Corolla 2TC 1588cc	EPC 32/36E	ADPT	S	9025
47-1741	75-79	Corolla 2TC 1588cc	EPC 32/36E	ADPT	S	8806
	All	Fits all Carbureted Corolla built after 7/74 w/ any Asian Carburetor	EPC 32/36E	ADPT	S	8806
	82-86	Tercel w/ 3AC	EPC 32/36E	ADPT	S	8806
47-1741	80-82	Corolla FWD 3TC 1800cc	EPC 32/36E	ADPT	S	8806
47-1751	84-85	Corolla FWD 4ALC 1587cc	EPC 32/36E	ADPT	S	8806
	86-90	Tercel w/ 3E	EPC 32/36E	ADPT	S	8806

**Carb. / Manifold:** DM = Direct Mount    MAN = Supplied with Manifold    ADPT = Adapter    IK = Installation Kit

**Air Filter:** X = Use Original    N/S = Not Supplied    (-IC) = Carb. Supplied w/Electric Idle Cut-Off Solenoid

**Linkage:** X = Use Original    S = Supplied    X1 = Use Throttle Arm from Original Carb.    X3 = Kit Supplied; A/T use Throttle Arm from Original Carb.

X2 = A/T may require Linkage Modification



# INTAKE - CARB. KITS & COMPONENTS

## Toyota continued

EMPI #	Year	Application	Carburetor	Carb. to Manifold	Linkage	Air Filter
47-1752	75-80	Corona 20R 2189cc	EPC 32/36A	ADPT	S	9025
47-1746	1981	Corona 22R 2366cc	EPC 32/36E	ADPT	S	9025
47-1741	82-86	Tercel 3AC 1452cc	EPC 32/36E	ADPT	S	8806
47-1751	86-90	Tercel 3E	EPC 32/36E	ADPT	S	8806
47-1752	75-80	Pick-Up 20R 2189cc	EPC 32/36A	ADPT	S	9025
47-1746	75-80	Pick-Up 20R 2189cc	EPC 32/36E	ADPT	S	9025
47-2746	75-80	Pick-Up 20R 2189cc (Hi-Perf. Conversion)	EPC 38E	ADPT	S	9025
47-1746	81-95	Pick-Up 22R 2366cc	EPC 32/36E	ADPT	S	9025
47-2746	81-95	Pick-Up 22R 2366cc (Hi-Perf. Conversion)	EPC 38E	ADPT	S	9025
47-1743	69-10/73	Land Cruiser F & 2F Eng.	EPC 32/36E	ADPT	S	9025
47-2743	69-10/73	Land Cruiser F & 2F Eng. (Hi-Perf. Conv.)	EPC 38E	ADPT	S	9025
47-2744	69-10/73	Land Cruiser F & 2F Eng. (Hi-Perf. Conv.)	EPC 38M	ADPT	S	9025
47-1743	74-87*	Land Cruiser F & 2F Eng.	EPC 32/36E	ADPT	S	9025
47-2743	74-87*	Land Cruiser F & 2F Eng. (Hi-Perf. Conv.)	EPC 38E	ADPT	S	9025
47-2744	74-87*	Land Cruiser F & 2F Eng. (Hi-Perf. Conv.)	EPC 38M	ADPT	S	9025

\*Note: 74-87 Land Cruiser may require linkage and pedal modification.

### 47-1560

Pedal & Cable for Toyota Land Cruisers, 74 to 87. This kit converts the original Toyota mechanical bell-crank linkage to a cable linkage.



47-1560

## REPLACEMENT CHOKE ELEMENTS

43-5903 **Complete** Replacement Water Choke Assembly for EPC 32/36A, 32/36 DGAV

**Toyota Design**

43-5920 **Complete** Replacement Water Choke Assembly for EPC 32/36A, 32/36 DGAV

**Suzuki Design**

43-5352 Repl. Manual Choke Assem. for EPC 32/36M, EPC 38, 32/36 DGV

43-5354 Manual Choke Cable  
Base of nut to end of spring area is 51"  
Base of nut total length is 62"

43-0620 Repl. Electric Choke Only for EPC 32/36F, 32/36 DFEV.

43-5351 Repl. Electric Choke Only for EPC 32/36, DGEV 32/36, EPC 38, 38 DGES



43-5903



43-5920



43-0620



43-5354



43-5352

<b>Carb. / Manifold:</b>	<b>DM</b> = Direct Mount	<b>MAN</b> = Supplied with Manifold	<b>ADPT</b> = Adapter	<b>IK</b> = Installation Kit
<b>Air Filter:</b>	<b>X</b> = Use Original	<b>N/S</b> = Not Supplied	<b>(-IC)</b> = Carb. Supplied w/Electric Idle Cut-Off Solenoid	
<b>Linkage:</b>	<b>X</b> = Use Original	<b>S</b> = Supplied	<b>X1</b> = Use Throttle Arm from Original Carb.	
	<b>X2</b> = A/T may require Linkage Modification		<b>X3</b> = Kit Supplied; A/T use Throttle Arm from Original Carb.	



## EMPI ELECTRONIC 'ALL-IN-ONE' SINGLE VACUUM ADVANCE DISTRIBUTOR

All new featuring a Magnetic Pick-up with the Amplifier attached to the Distributor for 'All-In-One' ease of installation. Features a smooth advance curve that starts at 1,000RPM and has a total of 18° @ 2,400 RPM with 10° Vacuum Advance.

Requires a Bosch Blue or other hi-energy coil (3.4 ohms primary/12k ohms secondary) w/ built-in resistor. An external ballast resistor may be used between power source and distributor if your coil does not feature a built-in resistor.

**(Must be used with a coil with an internal resistor or an external ballast resistor must be used)**

- Now with black cap
- May require mounting at 180° to clear some fuel pumps
- Better acceleration... helps eliminate the 'flat spot' on take-off
- Cooler engine temps
- More power throughout the advance curve

Fits the following models (12 volt only):

Type I – Bug/Ghia 1946-1979 (Except EFI Models)

Type 181, 1973-1975 Thing

Type II: 1950-1971 Bus/Transporter

- 9437-B** EMPI Electronic 'All-In-One' Single Vacuum Advance Distributor
- 16-9438** Replacement Black Cap for 9437-B Distributor Only
- 16-9439** Replacement Rotor for 9437-B Distributor Only
- 16-9440** Replacement Dust Cover for 9437-B Distributor Only



## EMPI CENTRIFUGAL ADVANCE DISTRIBUTORS

EMPI now offers four distributors. Perfect for Drag and Hot Street. Our Comp Distributors have an advance curve that will allow idle at nearly 0 degrees and advance up to 40 degrees. Our Street Distributors have the same advance curve as the 009. Both utilize the same tune-up components as the 009 and come complete with O-ring.

- 9431-B** EMPI Street Model Centrifugal Advance Distributor, **Standard Curve** similar to Bosch 009. (Boxed)
- 9430-B** EMPI Comp Model Centrifugal Advance Distributor, **Competition Curve**, Not for Street Use (Boxed)
- 9428-B** **NEW!** EMPI Street Model **Chrome** Centrifugal Advance Distributor, **Standard Curve** similar to Bosch 009. (Boxed)
- 9441-B** EMPI Street Model Centrifugal Advance Distributor w/Electronic Ignition Eliminates Points and Condenser (Boxed) **(Must be used with a coil with an internal resistor or an external ballast resistor must be used)** **Standard Curve** similar to Bosch 009.



## EMPI REPLACEMENT PARTS

The components below will also fit the Bosch 009 Distributor.

- 16-9433** Replacement Points for EMPI Distributor/009, Each (Bulk P/N: 16-9433-B)
- 16-9434** Replacement Condenser for EMPI Distributor/009, Each (Bulk P/N: 16-9434-B)
- 16-9435** Replacement Cap for EMPI Distributor/009, Each (Bulk P/N: 16-9435-B)
- 16-9436** Replacement Rotor for EMPI Distributor/009, Each (Bulk P/N: 16-9436-B)





# IGNITION COMPONENTS

## EMPI ACCU-FIRE ELECTRONIC IGNITION KIT

Turns your standard ignition into an Electronic Ignition at an affordable price. Eliminates points and condenser. Dust and water resistant. One kit fits both the 009 and stock vacuum advance distributors that utilize Bosch 044 points. Specification for coils are Primary 3.4 Ohms, Secondary 7.8 Ohms. **(Must be used with a coil with an internal resistor or an external ballast resistor must be used).**

9432                      **Accu-Fire** Electronic Ignition Kit



## PERTRONIX IGNITOR ELECTRONIC IGNITION

Dependable, self contained and maintenance free, the Ignitor delivers twice the voltage to the spark plugs and features an Adaptive Dwell that maintains peak energy throughout the entire RPM range, reducing misfires while improving engine performance. Legal in all 50 states. (C.A.R.B. E.O. #D-57-22)

17-2985                      Ignitor Type 1 68-73 for Vacuum Advance Distributors  
17-2986                      Ignitor Type 1 68-73 for 050 and 009 Distributors  
17-2987                      **Ignitor II** Type 1 for 050 and 009 Distributors



## COMPUFIRE D.I.S. IGNITION SYSTEM

Eliminates points, rotor, condenser and even the distributor cap! High-Energy Coil fires direct to plugs, having received signal from an electronic sensor. Totally water, dust and dirt proof and fires alternate cylinder simultaneously for cleaner, more efficient fuel burn. **Requires centrifugal advance distributor EMPI P/N: 9430-B, 9431B.**

9419                      D.I.S. Ignition System, w/Blue Wires  
9420                      D.I.S. Ignition System, w/Yellow Wires  
9426                      Tach Adapter for P/N: 9419/9420



## COMPUFIRE ELECTRONIC IGNITION KITS

Turn your standard ignition into an Electronic Ignition with this conversion kit. Eliminates points and condenser. Dust and water resistant. Flawless ignition performance with no points to "bounce". (Similar to EMPI Accu-Fire P/N: 9432). **(Must be used with a coil with an internal resistor or an external ballast resistor must be used).**

9421                      Electronic Ignition Kit, 009 Distributor  
9422                      Electronic Ignition Kit, Stock Distributor  
9421-3                      Replacement Rotor for P/N: 9421/9422



## BILLET ALUMINUM DISTRIBUTOR COVER

Give your centrifugal advance distributor that billet look. Attaches securely with set screws to EMPI P/N 9430-B, 9431B, 9441-B or Bosch 009 Distributors.

16-9545                      **Billet Aluminum** Distributor Cover





## TRANSPARENT DISTRIBUTOR CAPS

Available in your choice of four different colors. Fits Bosch 009 style distributors.

- 8790 Distributor Cap, Clear
- 8791 Distributor Cap, Red
- 8792 Distributor Cap, Blue
- 8793 Distributor Cap, Gold/Yellow



9433



## COMPONENTS FOR BOSCH 009 DISTRIBUTORS

- 9433 Replacement Points, Each  
(Bulk P/N: 01 011)
- 9434 Replacement Condenser, Each  
(Bulk P/N: 02 086)
- 9435 Replacement Cap, Each  
(Bulk P/N: 03 010)
- 9436 Replacement Rotor, Each  
(Bulk P/N: 04 110)



9435



9434



9436



98-9815-B

NEW!



98-9817-B

NEW!

## BOSCH IGNITION COMPONENTS

- 98-9815-B **NEW!** Bosch Condenser, Type 1, 61 to 64  
(Ref. P/N: 02-006)
- 98-9816-B **NEW!** Bosch Condenser, Type 1, 65 to 70  
(Ref. P/N: 02-007)
- 98-9817-B **NEW!** Bosch Condenser, Type 3, 68 to 71  
(Ref. P/N: 02-039)
- 98-9818-B **NEW!** Bosch Condenser, Type 3, 1967, 65 to 70, Longer Green Wire  
(Ref. P/N: 02-069)
- 98-9819-B **NEW!** Bosch Distributor Cap, 36hp, 010, Black  
(Ref. P/N: 03-019)
- 98-9820-B **NEW!** Bosch Distributor Cap, 1969 & up, 009, Black  
(Ref. P/N: 03-172)
- 98-9821-B **NEW!** Bosch Rotor  
(Ref. P/N: 04-004)
- 98-9822-B **NEW!** Bosch Rotor, 36hp, 010  
(Ref. P/N: 04-008)



98-9816-B

NEW!



98-9947-B

NEW!



98-9820-B

NEW!



98-9819-B

NEW!



98-9821-B

NEW!



98-9822-B

NEW!



## BOSCH RPM LIMITING DISTRIBUTOR ROTORS

An economical and safe way to protect your engine – limit your RPM. Choose at what RPM you want the rotor to stop firing. Your engine will run smoothly at all RPM ranges, right up to the predetermined limit. Never worry about miss-shifts again. Fits all 009, including EMPI's mechanical advance distributors and 1971 and later vacuum advance distributors using ignition points. Does not work with electronic ignitions.



- 98-9603 Bosch RPM Limiting Distributor Rotor, 5400 RPM, Each  
(Ref. P/N: 04-016)
- 98-9604 Bosch RPM Limiting Distributor Rotor, 5800 RPM, Each  
(Ref. P/N: 04-030)
- 98-9605 Bosch RPM Limiting Distributor Rotor, 6500 RPM, Each  
(Ref. P/N: 04-023)
- 98-9606 Bosch RPM Limiting Distributor Rotor, 6800 RPM, Each  
(Ref. P/N: 04-024)
- 98-9607 Bosch RPM Limiting Distributor Rotor, 7100 RPM, Each  
(Ref. P/N: 04-028)



# IGNITION COMPONENTS

## **BILLET DISTRIBUTOR CLAMP**

Polished Billet Aluminum Distributor Clamp. Great looking and functional with ignition timing marks in 5° increments from 10-50° and concealed Allen Bolt.

**17-2925** Billet Aluminum Distributor Clamp w/ Ignition Timing Marks



## **BILLET DISTRIBUTOR CLAMP**

Precision machined billet aluminum distributor clamp is the high tech solution to problems caused by bent or worn out stamped style clamps.

**8912** Billet Aluminum Distributor Hold Down Clamp



## **DISTRIBUTOR CLAMPS**

A high quality replacement for worn out or poor fitting existing clamps. Available in zinc or chrome plated.

**8910** Chrome Distributor Clamp w/Nut and Bolt, Each

**8909** Zinc Distributor Clamp w/Nut and Bolt, Each  
(Bulk P/N: 113 905 250)



## **COMPU-FIRE HIGH OUTPUT 35,000 VOLT COIL**

For use with points or electronic ignition, this Chrome coil is epoxy filled and produces 35,000 volts of power. These will not work on electronic ignition w/o ballast resistor.

**17-2959** Compu-Fire 35,000 Volt Chrome Coil, 12-Volt, Each



## **HIGH OUTPUT COILS**

Popular hi-performance coils in 6 and 12-Volt.

**9408-B** \*Bosch Blue Coil, w/o Resistor, w/Bracket, 6-Volt (Boxed), Silver in Color

(Ref. P/N: 00 016)

**9409-B** Bosch Blue Coil, w/Bracket, 12-Volt (Boxed), Blue in Color  
(Ref. P/N: 00 012) Primary 3.4 Ohms, Secondary 7.8 Ohms  
Works with electronic ignition.

**9406-B** \*Coil, w/o Resistor-w/Bracket, 12-Volt (Boxed), Blue in Color, EMPI Brand

**9404-B** \*Coil, Bosch, Oil Filled, w/o Resistor, 12-Volt (Boxed), Black in Color (Mexico)



\* Note: These 3 coils can be used with points. They would need 3.4 ohms ballast resistor for electronic ignition.

## **STAINLESS STEEL COIL COVER KIT**

Polished Stainless Steel Coil Cover fits all stock style coils for that "Show Look". Includes chrome bracket & hardware and is easy to install.

**9064** Stainless Steel Coil Cover Set



## **BILLET COMBO FUEL PUMP BLOCK-OFF / COIL MOUNT**

Polished aluminum Combo Mount serves as a fuel pump block-off, breather vent and ignition coil holder. Features a 3/8 NPT outlet for vent. Great looking and functional - what more can you ask for?

**17-2926** Billet Combo Fuel Pump Block-Off / Coil Mount



# IGNITION COMPONENTS



9407 EMPI 7MM SILICONE HI TEMP COPPER CABLE

9411 EMPI 7MM SILICONE HI TEMP COPPER CABLE



## EMPI SILICONE IGNITION WIRE SETS

EMPI 7mm wire sets feature a double-jacket silicone cover to protect against heat and deluxe spark plug boots that seal at the cylinder tin. The extra long 22" coil wire allows the coil to be mounted in various locations. Tailored to fit your VW. Choose from a variety of colors in Copper Core Non-Suppressed. **Made in USA.**

- 9400 EMPI Silicone Wire Set, Copper Core, Yellow
- 9407 EMPI Silicone Wire Set, Copper Core, Blue
- 9411 EMPI Silicone Wire Set, Copper Core, Red



## STOCK IGNITION WIRE SET

Super High quality, **Made in USA**, stock replacement 7mm Suppressed wire set with large plug seals.

- 9314 Stock Ignition Wire Set, Black  
(Bulk P/N: 111 998 031A)



## 90° MEGAVOLT IGNITION WIRE SETS

We now offer 8mm MEGAVOLT premium wire sets with 90° end caps for a better fit which results in that cleaner look! We have also added our new stealth gray color. We have still retained the superior quality spark plug boots and extra long coil wire to meet your demands for the best ignition wire sets available. **Copper Core Non-Suppressed.** These wire sets are designed for all Type 1, 2, and 3 engine configurations. **Made in USA.**

- B35202 **NEW!** 90° Megavolt™ Ignition Wires, Yellow
- B352022 **NEW!** 90° Megavolt™ Ignition Wires, Blue
- B352023 **NEW!** 90° Megavolt™ Ignition Wires, Red
- B352026 **NEW!** 90° Megavolt™ Ignition Wires, Grey



## TAYLOR SPIRO PRO "409" RACE WIRE SETS

If 7mm wire isn't large enough for you or you have a high output ignition that's overpowering your current wires then these 10.4mm diameter wires are the ones for you! Features include: 8mm silicone ignition wire core, woven fiberglass over-braid and silicone jacketed top layer. Comes with 30" coil wire that can be cut to your exact length. Available in Red, Blue or Black. **Made in USA.**

- 9395 "409" Spiro Pro Race Wire Set, Black
- 9396 "409" Spiro Pro Race Wire Set, Blue
- 9397 "409" Spiro Pro Race Wire Set, Red



## BOSCH IGNITION WIRE SETS



High quality Bosch ignition wires

- 98-9986-B Ignition Wire Set, Type 1 50-79, Ghia 56-74, Type 2 50-71, Ea (Ref. P/N: 111 998 031) **(Bakelite Ends)**
- 98-9921-B Premium Ignition Wire Set, Type 1 50-79, Ghia 56-74, Type 2 50-71, Straight, Ea (Ref. P/N: 09-001)
- 98-9922-B Premium Ignition Wire Set, Type 2 72-79, Straight, Ea (Ref. P/N: 09-171)
- 98-9923-B Premium Ignition Wire Set, Type 3 65-67, Straight, Ea (Ref. P/N: 09-003)
- 98-9924-B Premium Ignition Wire Set, Type 3 68-73, 90 Degree, Ea (Ref. P/N: 09-004)





# IGNITION COMPONENTS

## COMPU-FIRE HIGH OUTPUT STARTERS

Compu-Fire's new Permanent Magnet Gear Reduction (PMGR) Starter Motor for all air-cooled Bug & Bus applications produces 2kw of starting energy by using modern permanent magnet field technology along with a precision wound high amperage armature. The gear reduction has a lower ratio (6:1) to allow easy starts for all large displacement high compression performance engines. The new Starter is assembled in the USA with 100% new components.

- 17-2957** Compu-Fire High Output Starter 12-Volt Type 1, Each
- 17-2958** Compu-Fire High Output Starter 12-Volt Type 2, for 091 Trans, Each (Early Bus w/002 transmission use P/N: 17-2957)



## BOSCH STARTERS

There is nothing like the cranking power of O.E.M. Bosch Starters. No Core Required

- 98-9112-B** Starter, 6-Volt Rebuilt, Type1/2/3 thru 66 (Ref. P/N: SR11X)
- 98-9110-B** Starter, 12-Volt New, Type1, 67-79 Exc. AutoStick Note new design with self supporting armature shaft. (Ref. P/N: SR15N)



## EMPI STARTER

High quality replacement 12-Volt starter. New - not rebuilt.

- 98-9114-B** Starter, 12-Volt New, Type1, 67-79 Exc. AutoStick (Ref. P/N: SR15NCH)



## HARD-START RELAY KIT - 12VOLT

Allows increased juice to the starter by momentarily by-passing the ignition switch. Easy installation.

- 17-2917** Hard-Start Relay Kit



## STARTER ADAPTER BUSHINGS / BOLT

These Bronze Bushings adapt early to late 6-Volt to 12-Volt starter and transaxle combinations.

- 4027** Bushing, Bronze, 12-Volt Starter to 6-Volt Transaxle (Thick)
- 4028** Bushing, Bronze, 6-Volt Starter to 12-Volt Transaxle (Thin)
- 98-1003** Starter Bolt, Each (Bulk P/N: 111 199 101)



## WIRE SEPARATORS

These Wire Separators are easy to install and really give your VW that detailed look. Complete kit includes five 2-wire and one 3-wire separator with an allen wrench for assembly. Fits 4 Cylinder engines. Available in five different colors or chrome.



8747

- 8747 Wire Separator Kit, Chrome
- 8748 Wire Separator Kit, Red
- 8749 Wire Separator Kit, Blue
- 8750 Wire Separator Kit, Yellow
- 8751 Wire Separator Kit, Black
- 8752 Wire Separator Kit, Neon Pink



## WATERPROOF IGNITION KITS

Available in two different colors, these two-piece kits cover your distributor cap and coil protecting them from the elements. A must for any Baja or Buggy.

- 9315 Waterproof Kit, Black, Set
- 9465 Waterproof Kit, White, Set



NEW!

## SPARK PLUG END FITTINGS

Spark Plug Terminal Nut attaches to threaded head of spark plugs. Allows for use of High Performance Wire Sets. Fits NGK & Bosch spark plugs.

- 9410 **NEW!** Spark Plug End Fittings (4)

**BOSCH**



## BOSCH SPARK PLUGS (SOLD AS EACH)

- 98-9931-B Spark Plug, 4 per Box, 14mm, 1/2" Reach, Each (Ref. P/N: WR7AC) Tip installed on plug.
- 98-9932-B Spark Plug, 4 per Box, 14mm, 1/2" Reach, Each (Ref. P/N: WR8AC) Tip installed on plug.
- 98-9933-B Spark Plug, 10 per Box, 14mm, 3/4" Reach, Each (Ref. P/N: W7CC) Tip installed on plug.
- 98-9934-B Spark Plug, 4 per Box, 14mm, 3/4" Reach, Each (Ref. P/N: WR8CC) Tip installed on plug.
- 98-9823-B **NEW!** Spark Plug, 4 per Box, 14mm, 3/4" Reach, Each (Ref. P/N: WR8DP) Tip installed on plug.

**NGK**



## NGK SPARK PLUGS (SOLD AS EACH)

- 98-9944-B Spark Plug, 4 per Box, 14mm x 1/2" Reach, Each (Ref. P/N: B6HS)
- 98-9937-B Spark Plug, 10 per Box, 12mm, 3/4" Reach, Each (Ref. P/N: DP7EA9)
- 98-9938-B Spark Plug, 10 per Box, 12mm, 3/4" Reach, Each (Ref. P/N: DP8EA9)
- 98-9939-B Spark Plug, 10 per Box, 12mm, 3/4" Reach, Each (Ref. P/N: DP9EA9) Tip installed on plug.
- 98-9945-B **NEW!** Spark Plug, 10 per Box, 14mm x 3/4" Reach, Each (Ref. P/N: B8ES) Tip installed on plug.



# IGNITION COMPONENTS

## EMPI 90 AMP ALTERNATORS

These alternators are Made in the USA, produce 90amps of electrical energy and feature an internal regulator to improve reliability, reduce operating temperatures and keep dust and silt out when used in off-road applications.

- 9458-7                    EMPI 90AMP Alternator w/o Dual Fan (U.S. Made)
- 9459-7                    EMPI 90AMP Alternator w/o Dual Fan, Polished (U.S. Made)
- 9460-7                    EMPI 90AMP Alternator with Dual Fan (U.S. Made)
- 9462-7                    EMPI 90AMP Alternator with Dual Fan, Polished (U.S. Made)



9458-7  
9460-7



9459-7  
9462-7

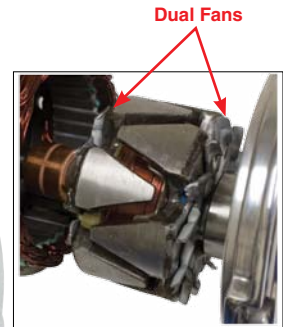

## BOSCH 55 AMP ALTERNATORS

- 9444-1                    Genuine Bosch AL82N Alternator  
(Ref. P/N: AL82N)



9444-1



## ALTERNATOR / GENERATOR BACKING PLATES

Choose Chrome or Black. The Black Kit can be painted to match your car. Fits Type 1 12-Volt with Alternator or Generator.

- 9056                    Steel Stock-Style 3-Piece Tin Kit, Chrome
- 9057                    Steel Stock-Style 3-Piece Tin Kit, Black
- 9071                    Steel Backing Plate, Chrome
- 8979                    Steel Backing Plate, Black



9071

9057

## ALTERNATOR / GENERATOR STAND

Available in Chrome and Stock Style. Complete the look with our accessory oil filler tubes.

- 8991                    Alt/Gen Stand, Chrome
- 9194                    Alt/Gen Stand, Raw Aluminum  
(Bulk P/N: 113 101 211G)
- 98-0141-B              Gasket, Generator Stand  
Type 1 60-79, Ghia 60-74, Type 2 61-71, Type 3 64-73, Each  
(Ref. P/N: 113 101 219)
- 98-0142-B              Deflector Plate, Gasket Generator Support,  
Type 1 60-79, Ghia 60-74, Type 2 63-71, Type 3 64-73, Each  
(Ref. P/N: 113 101 221B)



8991

9194

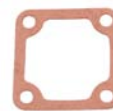

98-0141-B



98-0142-B



9445-7

## EMPI 55 AMP ALTERNATORS

EMPI 55amp alternator built with all new components – no rebuilt parts are used. This alternator is used in our 9445, 9446 and 9450 Alternator Conversion Kits.

9445-7 EMPI 55AMP Alternator

9452 Replacement Regulator only for EMPI 55 AMP Alternator, Each



9452



9453-7

## EMPI 75 AMP CHROME ALTERNATOR

Get the power you need to operate amp hungry accessories and high output ignition systems. This alternator pushes out more amps than stock units, and is all new, no rebuilt components are used.

9453-7 EMPI 75AMP Alternator, Chrome



9058

8903

## ALTERNATOR / GENERATOR STRAP

Stock style clamp available in Polished Chrome or Gold Zinc finish. Secures 12-Volt alternator or generator while adding a finished look.

8903 Alt/Gen Strap, Chrome

9058 Alt/Gen Strap, Zinc

(Bulk P/N: 113 903 141B)



16-5161

## STAINLESS STEEL T-BOLT STYLE ALT / GEN STRAP

The ultimate alternator / generator strap. The great and long lasting looks, strength and durability of stainless steel with the positive security of the T-Bolt style. A must for off road.

16-5161 Stainless Steel T-Bolt Strap



9445

## ALTERNATOR CONVERSION KIT

Replace your 12-Volt generator with a high-charging alternator. Kit comes complete with a new EMPI 55AMP Alternator. Kits include Stand, Strap and 3-Piece Backing Plate Set. Also a great start for converting a 6-Volt system to 12-Volt!

9445 Alternator Conversion Kit

9446 Alt. Conversion Kit w/Zinc Pulley & Belt

9445-7 EMPI 55AMP Alternator Only



9450

## ALTERNATOR KIT WITH CHROME COMPONENTS

Kit comes complete with a new EMPI 55AMP Alternator. Kit includes Chrome Stand, Chrome Strap, Chrome Pulley, Fan Belt and 3-Piece Tin Set with chrome face plate and chrome rear piece. (Note: Alternator is NOT Chrome).

9450 Alternator Kit w/Chrome Components

9445-7 EMPI 55AMP Alternator Only



9451

## CHROME 75 AMP ALTERNATOR KIT W/ CHROME COMPONENTS

Kit comes complete with a new Chrome EMPI 75AMP Alternator. Kit includes Chrome Stand, Chrome Strap, Chrome Pulley, Fan Belt and 3-Piece Tin Set with chrome face plate and chrome rear piece.

9451 Chrome Alt. Kit w/ Chrome Components

9453-7 EMPI Chrome 75AMP Alternator Only



# IGNITION COMPONENTS

## 12-VOLT ALTERNATOR / GENERATOR PULLEY

Your choice of a Chrome or Gold-Zinc finish pulley along with the necessary related hardware. (Pulleys require a minimum of 10 shims to properly install and avoid damage).

- 9166** 12-Volt Pulley, Gold-Zinc  
(Bulk P/N: 043 903 109)
- 9191** 12-Volt Pulley, Chrome

- 98-9012** 12-Volt Pulley, w/ Air Fins, Black  
(Bulk P/N: 040 903 109)

- 98-0111** Alt/Gen Pulley Woodruff Key, 2 pcs.  
(Bulk P/N: N012 705 1)

- 9197** Alt/Gen Shim Kit, 10 Shims
- 9197-B** Bulk Alt/Gen Shims, 100 Shims  
(Ref. P/N: 111 903 131A)



## BILLET ALUMINUM 12-VOLT ALT / GEN PULLEY

EMPI now offers a 6061 T-6 aluminum front pulley half. Featuring machined holes in it for a bold new look which also functions to rid the belt area of dirt and debris. It is also offered complete with a silver zinc steel inner pulley half if you want a complete assembly.

- 33-1040** Billet Aluminum Generator Pulley, Outer Half Only
- 33-1041** Billet Aluminum Generator Pulley, Outer Half w/Metal Inner



## BILLET ALTERNATOR / GENERATOR PULLEY

This billet pulley spins straight and true, the perfect addition to your killer engine. Available in anodized black or polished. Supplied with Woodruff Key.

- 16-9706** Billet Alternator / Generator Pulley, Black, Each
- 16-9707** Billet Alternator / Generator Pulley, Polished, Each
- 16-9708** Special Nut Washer Set (For 16-9706 and 16-9707 Pulley's Only)
- 16-9709** Shims (5) for Billet Pulley



## FINNED ALTERNATOR / GENERATOR PULLEY COVERS

See-Thru plastic with attractive fins. Matches other Finned accessories. Fits over Alt/Gen pulley.

- 8925** Finned Pulley Cover, Clear
- 8926** Finned Pulley Cover, Red
- 8927** Finned Pulley Cover, Blue
- 8928** Finned Pulley Cover, Gold/Yellow
- 8929** Finned Pulley Cover, Smoke/Grey

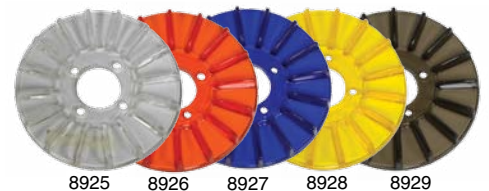

## CHROME ALTERNATOR / GENERATOR NUT & SPACER

Chrome cone-shaped spacer and smooth cap-style pulley nut adds the finished look to all stock and chrome pulleys.

- 9119** Chrome Alt/Gen Nut & Spacer, 2-Piece Set



## CARB. SPACERS / ALTERNATOR CONVERSION

Sometimes necessary for Alternator Conversion. Two spacers available. 3245 spacer is for stock Solex/Brosol 28/30 Carburetor and is 1" thick with 2 1/8" hole to hole measurement. 16-9705 is for 34 Pict Carburetor and measures 3/8" thick with 2 11/16" hole to hole measurement.

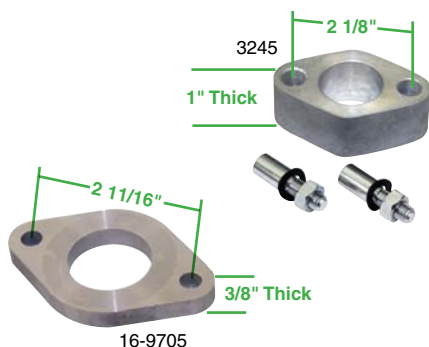

- 3245** Carb. Adapter Kit w/Studs, Nuts & Gaskets  
**16-9705** 34 PICT Carburetor Spacer, Each

## BOSCH GENERATORS

Don't settle for anything less than the best...**Bosch**. No Core Required



- 98-9031-B** Gen., 12-Volt New, Type 1, 67-73, Type 2, 67-68  
 (Ref. P/N: GR15N)  
**98-9068-B** Voltage Reg., 12-Volt, Type 1/3, 67-73 / Type 2, 67-68  
 (Ref. P/N: 30 019)

## GENERATOR BRUSH COVER

Our black plastic Generator Brush Cover keeps dirt and moisture out of the generator, helping to extend generator life. Fits BOSCH GR15/17 generators.



- 8902** Generator Brush Cover, Each  
 (Bulk P/N: 113 903 531)

## STAINLESS STEEL GENERATOR COVER

Polished Stainless Steel Cover fits perfectly over your stock generator and gives your car that "Show Look". Air holes allow for cooling.



- 9036** Stainless Steel Generator Cover

## BRAIDED BATTERY GROUND STRAPS

Stock-style braided Battery Ground Straps for reliable grounding of your chassis and battery. **New No-Lead Design**. Available in two lengths for all applications.



- 9467** Braided Ground Strap - Chassis, 9"  
**9468** Braided Ground Strap - Chassis, 12"



# EXHAUST COMPONENTS

## EMPI PREMIUM EXHAUST SYSTEMS

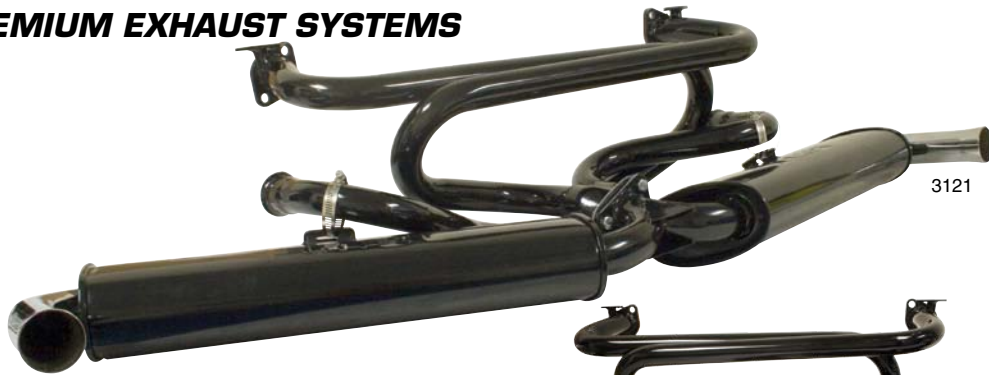

3121



3120

Featuring the EMPI Premium Extractor, made from 1 3/8", 16 gauge steel – mandrel bent for smooth flow and good looks. Extra thick flanges are surface ground to ensure flat sealing surface and finish ground on I.D.s.

Collector is centered and the small 3-bolt flange is at the 1:00 position. Available with Single or Dual Quiet Mufflers...totally re-designed for a perfect, level fit.

Comes with high quality gaskets, stainless steel bolts and copper nuts to resist corrosion. Available with Black painted finish or super durable Ceramic Silver Coat. Fits 1300-1600 Type 1 based engines.

- **Premium Quality - Totally re-designed for a perfect, level fit.**
- **Centered Collector - Small 3-Bolt Flange**
- **1 3/8" Mandrel Bent Steel**
- **Single or Dual Quiet Mufflers w/level fit**



Re-Designed New Level Fit Mufflers and Collector is Centered on Header at 1:00 Position

- 3120 EMPI Premium Exhaust System w/Single Quiet Muffler, Type 1
- 3121 EMPI Premium Exhaust System w/Dual Quiet Mufflers, Type 1

### EMPI PREMIUM EXTRACTOR ONLY

EMPI's new premium extractors are made from 1 3/8" 16 gauge steel with extra thick flanges. Tubes are mandrel bent to insure smooth exhaust gas flow. All flanges are surface ground to ensure a flat sealing surface and finish ground on I.D.'s. The 3-bolt muffler flange is at the 1:00 position and will accept P/N 3200, 3201, 3202, 3204, 3205, 3122, 3123, 55-3122, 55-3123 mufflers and P/N 3696, 3697 stingers. Comes with high quality gaskets, stainless steel bolts and copper nuts to resist corrosion. Fits 1300-1600cc Type 1 based engines.



3102



NEW!

3477

- 3100 Premium Extractor Only, Black
- 3102 Premium Extractor Only, **Ceramic Coated**

3477 **NEW!** S/S Stinger Only w/ Swivel Flange. Fits 3100 / 3102 / 3767

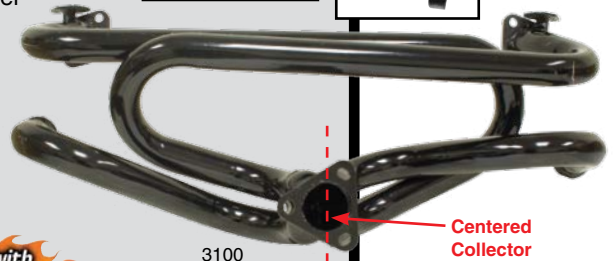
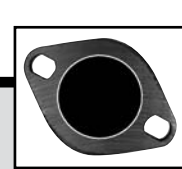

3100

Centered Collector



Surface ground flanges!

EMPI Headers and Mufflers are coated with a layer of paint which acts as a rust inhibitor - and may burn off once they get hot. It is best to clean off the coating with a good solvent then paint the system with quality hi-temp paint. Systems are not warranted against rust. EMPI offers many Exhaust Systems pre-finished in a Ceramic Coating. Discoloration is not a manufacturing, **chrome** process or **stainless steel** issue. High exhaust temperatures exceed the capabilities of chrome plating to handle the heat without discoloration. Stainless Steel systems may also experience discoloration due to engine heat. EMPI does not warranty Exhaust Systems against discoloration or bluing.

# EXHAUST COMPONENTS



## EMPI MUFFLERS FOR PREMIUM EXTRACTORS

### SINGLE QUIET MUFFLER

- 3122** Single Quiet Muffler (**Black w/ Chrome Tip**) for EMPI Premium Exhaust System, Type 1 (Fits 3100 and 3102 Extractors Only)
- 55-3122** Single Quiet Muffler (**Ceramic Coated**) for EMPI Premium Exhaust System, Type 1 (Fits 3100 and 3102 Extractors Only)



3122



55-3122



### DUAL QUIET MUFFLER

- 3123** Dual Quiet Muffler (**Black w/ Chrome Tip**) for EMPI Premium Exhaust System, Type 1 (Fits 3100 and 3102 Extractors Only)
- 55-3123** Dual Quiet Muffler (**Ceramic Coated**) for EMPI Premium Exhaust System, Type 1 (Fits 3100 and 3102 Extractors Only)



3123



55-3123

## PHAT BOY MUFFLERS FOR PREMIUM EXTRACTORS

These bad PHAT Boys provide maximum flow and power with a distinctive turbo hush. They won't see you coming; they will hear you going. We make 3 versions, black, ceramic coated steel and stainless steel for Type 1's and Type 2's. Must use extractor P/N's 3100 or 3102 listed on page 159.

### TYPE 1 (1300-1600cc, 66-73)

- 3200** PHAT Boy Muffler, Black - Fits P/N: 3100 and 3102
- 3201** PHAT Boy Muffler, **Ceramic Coated** - Fits P/N: 3100 and 3102
- 3202** PHAT Boy Muffler, **Stainless Steel** - Fits P/N: 3100 and 3102

### TYPE 2 (1963-71)

- 3204** PHAT Boy Muffler, Black - Fits P/N: 3100 and 3102
- 3205** PHAT Boy Muffler, **Ceramic Coated** - Fits P/N: 3100 and 3102
- 3206** **NEW!** PHAT Boy Muffler, **Stainless Steel** - Fits P/N: 3100, 3102 and 3767

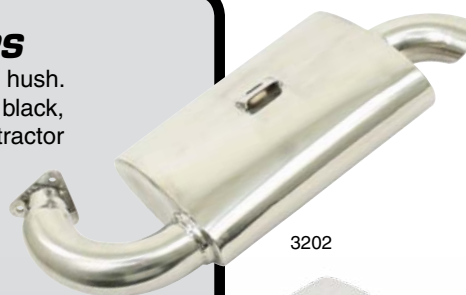

3202



3206



EMPI Headers and Mufflers are coated with a layer of paint which acts as a rust inhibitor - and may burn off once they get hot. It is best to clean off the coating with a good solvent then paint the system with quality hi-temp paint. Systems are not warranted against rust. EMPI offers many Exhaust Systems pre-finished in a Ceramic Coating. Discoloration is not a manufacturing, **chrome** process or **stainless steel** issue. High exhaust temperatures exceed the capabilities of chrome plating to handle the heat without discoloration. Stainless Steel systems may also experience discoloration due to engine heat. EMPI does not warranty Exhaust Systems against discoloration or bluing.





# EXHAUST COMPONENTS

## EXHAUST SYSTEMS - SMALL 3 BOLT FLANGE IN "1:00" POSITION

The most popular of our extensive precision-designed VW Exhaust Systems. These systems feature 1 3/8" tubing with Small 3 Bolt Muffler Flange and Flared Chrome Muffler Tips. All systems include aluminum flex hose and installation kit. Collector is off-set, non-centered.

Header flange is at "1:00" Position, except Type 3 system.

Ceramic coated components available separately for most of these systems. Refer to component only listings.

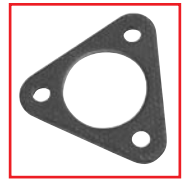

1:00 Position Except Type 3

### SINGLE QUIET EXHAUST SYSTEMS

- 3647 Type 1 & Ghia, 1300-1600cc, 66-73
- 3655 Type 2, 63-71
- 3661 Type 3, 1500-1600cc



3647



3661

### DUAL QUIET EXHAUST SYSTEMS

- 3648 Type 1 & Ghia, 1300-1600cc, 66-73
- 3656 Type 2, 63-71
- 3662 Type 3, 1500-1600cc



3648



3662

### SINGLE GLASS PACK EXHAUST SYSTEMS

- 3641 Type 1 & Ghia, 1300-1600cc, 66-73
- Type 2, 63-71



3641

### HEADER ONLY - SMALL 3 BOLT FLANGE

- 3682 Type 1 & Ghia, 1300-1600cc, 66-73
- Type 2, 63-71
- 55-3682 Type 1 & Ghia, 1300-1600cc, 66-73
- Type 2, 63-71, **Ceramic Coated**
- 3661-7 Type 3, 1500-1600cc
- 55-3661-7 Type 3, 1500-1600cc, **Ceramic Coated**



3682



EMPI Headers and Mufflers are coated with a layer of paint which acts as a rust inhibitor - and may burn off once they get hot. It is best to clean off the coating with a good solvent then paint the system with quality hi-temp paint. Systems are not warranted against rust. EMPI offers many Exhaust Systems pre-finished in a Ceramic Coating. Discoloration is not a manufacturing, **chrome** process or **stainless steel** issue. High exhaust temperatures exceed the capabilities of chrome plating to handle the heat without discoloration. Stainless Steel systems may also experience discoloration due to engine heat. EMPI does not warranty Exhaust Systems against discoloration or bluing.



## REPLACEMENT MUFFLERS WITH CHROME TIP SMALL 3 BOLT FLANGE IN "1:00" POSITION

**3644** Single Quiet Black with Chrome Tip - Type 1 & Ghia, 66-73  
**55-3644** Single Quiet - Type 1 & Ghia, 66-73, **Ceramic Coated**

**3645** Dual Quiet Black with Chrome Tips - Type 1 & Ghia, 66-73   
**55-3645** Dual Quiet - Type 1 & Ghia, 66-73, **Ceramic Coated**



**3666** Single Quiet Black with Chrome Tip - Type 2, 63-71  
**55-3666** Single Quiet - Type 2, 63-71, **Ceramic Coated**

**3667** Dual Quiet Black with Chrome Tips - Type 2, 63-71   
**55-3667** Dual Quiet - Type 2, 63-71, **Ceramic Coated**



**3668** Single Quiet Black with Chrome Tip - Type 3  
**55-3668** Single Quiet - Type 3, **Ceramic Coated**

**3669** Dual Quiet Black with Chrome Tips - Type 3



**3663** Single Glass Pack with Chrome Tip, Type 1 & 2 Only

## STINGERS & BAFFLES - SMALL 3 BOLT FLANGE

Stingers, Baffles and Fiberglass Wrapped Baffles reduce back-pressure. Baffle is easily removed for competition use. For P/N: 3682 Headers.



**3658** Long Angled Stinger, Small Flange, Black

**3780-1** Fiberglass-Wrapped Baffle



## SWIVEL FLANGE STINGERS

The EMPI designed Swivel Flange Stinger eliminates the guess-work. The stinger will rotate to any desired position until tightened. Available in chrome, black or ceramic coat finish. Fits most manufacturers Small 3 Bolt Flange systems. These stingers fit 3682, 3699 and 7320 exhaust.

**3696** Swivel Flange Stinger, Black



**55-3696** Swivel Flange Stinger, **Ceramic Coated**

**3697** Swivel Flange Stinger, Chrome

**3780-1** Fiberglass-Wrapped Baffle

EMPI Headers and Mufflers are coated with a layer of paint which acts as a rust inhibitor - and may burn off once they get hot. It is best to clean off the coating with a good solvent then paint the system with quality hi-temp paint. Systems are not warranted against rust. EMPI offers many Exhaust Systems pre-finished in a Ceramic Coating. Discoloration is not a manufacturing, **chrome** process or **stainless steel** issue. High exhaust temperatures exceed the capabilities of chrome plating to handle the heat without discoloration. Stainless Steel systems may also experience discoloration due to engine heat. EMPI does not warranty Exhaust Systems against discoloration or bluing.



# EXHAUST COMPONENTS

## VW THING EXHAUST

2 Tip Extractor for '73 - '75 Thing, featuring 1 3/8" tubing and adjustable tips for body clearance. Available in black or ceramic coated.

- 3425 Thing Exhaust, 73-75, Black
- 55-3425 Thing Exhaust, 73-75, **Ceramic Coated**



## HIGH MOUNT QUIET MUFFLER

Mounts muffler high up next to engine on the right side for increased ground clearance. Looks and sounds great. Securely mounts to cylinder head. Fits Type 1, 1300-1600cc. Collector is off-set, non-centered. For use with P/N: 3682 Header.

- 3682 Header Only, Type 1, 1300-1600cc
- 55-3682 Header Only, Type 1, 1300-1600cc, **Ceramic Coated**
- 3650 High Mount Quiet Muffler, Black
- 55-3650 High Mount Quiet Muffler, **Ceramic Coated**



## ECONO EXHAUST SYSTEM

Designed with adjustable slip joints on header pipes, this inexpensive system fits all Type 1 & 2 models including late 40HP, 1300-1600cc... any upright model with fresh-air heaters. Includes hardware, gaskets and aluminum flex hose.

- 3300 Econo Exhaust System

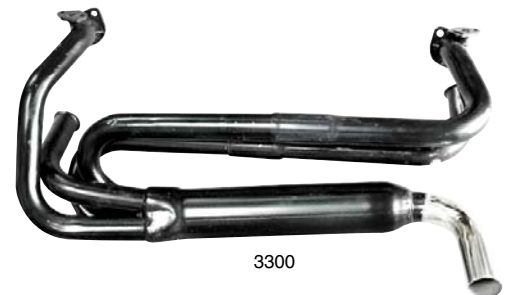

## TUCK-AWAY DUAL EXHAUST SYSTEM

This exhaust system is hidden behind the rear apron and features a dual glass pack muffler with Dual Chrome Tips and fits all 1300-1600cc Bug applications. This system features 1 1/2" tubing. Complete system including hardware.

- 3602 Tuck-Away Dual Exhaust
- 3603 Replacement Dual Muffler Only
- 3602-7 Header Only   
(Can be used for custom exhaust systems)

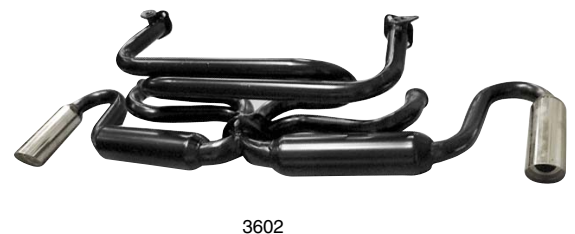

EMPI Headers and Mufflers are coated with a layer of paint which acts as a rust inhibitor - and may burn off once they get hot. It is best to clean off the coating with a good solvent then paint the system with quality hi-temp paint. Systems are not warranted against rust. EMPI offers many Exhaust Systems pre-finished in a Ceramic Coating. Discoloration is not a manufacturing, **chrome** process or **stainless steel** issue. High exhaust temperatures exceed the capabilities of chrome plating to handle the heat without discoloration. Stainless Steel systems may also experience discoloration due to engine heat. EMPI does not warranty Exhaust Systems against discoloration or bluing.

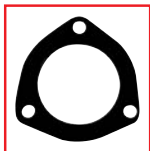

## EXHAUST SYSTEMS - LARGE 3 BOLT FLANGE

These precision designed systems feature 1 1/2" Tubing and Large 3 Bolt Muffler Flange. Mufflers feature Black tips. All systems include aluminum flex hose and installation kit.



3312

### SINGLE QUIET EXHAUST SYSTEMS

**3312** Single Quiet System  
Type 1 & Ghia, 1300-1600cc, 66-73



3310

### SINGLE GLASS PACK EXHAUST SYSTEM

**3310** Type 1 & Ghia, 1300-1600cc, 66-73



Available with  
Ceramic Coating

55-3474

### HEADER ONLY - LARGE 3 BOLT FLANGE

**3474** Type 1 & Ghia, 1300-1600cc, 66-73  
**55-3474** Type 1 & Ghia, 1300-1600cc, 66-73,  
**Ceramic Coated**

### REPLACEMENT MUFFLERS - LARGE 3 BOLT FLANGE

**3324** Single Quiet, Type 1 & Ghia, 66-73  
**55-3324** Single Quiet, Type 1 & Ghia, 66-73,  
**Ceramic Coated**

**3322** Single Glass Pack Black w/Chrome Tip  
Type 1 & Ghia, 66-73

## LATE TYPE 2 & TYPE 4 EXHAUST SYSTEMS

This tuned system increases horsepower and improves appearance of your late model Bus or 411. Available with Quiet Pack Muffler and includes all necessary hardware.



3439

### QUIET EXHAUST SYSTEMS

**3439** Type 2 & 411, 72-74, Large 3 Bolt Flange  
**3442** Replacement Quiet Muffler - Fits P/N: 3439  
**3319-7** Header Only for P/N: 3439



3714

**3714** Type 2, 75-78, Small 3 Bolt Flange  
*(Eliminates Catalytic Converter - Not Legal for Street Use in CA)*



3484

**3715** Replacement Quiet Muffler - Fits P/N: 3714  
**3714-7** Header Only for 3714

### 2 TIP GT EXHAUST SYSTEM - TYPE 2/4

**3483** Type 2 & 411, 72-74  
Black with Chrome Tips



3483

### 4 TIP GT EXHAUST SYSTEM - TYPE 2

**3484** Type 2 Bus, 75-78 Black with Chrome Tips  
*(Eliminates Catalytic Converter- Not Legal for Street Use in CA)*

EMPI Headers and Mufflers are coated with a layer of paint which acts as a rust inhibitor - and may burn off once they get hot. It is best to clean off the coating with a good solvent then paint the system with quality hi-temp paint. Systems are not warranted against rust. EMPI offers many Exhaust Systems pre-finished in a Ceramic Coating. Discoloration is not a manufacturing, **chrome** process or **stainless steel** issue. High exhaust temperatures exceed the capabilities of chrome plating to handle the heat without discoloration. Stainless Steel systems may also experience discoloration due to engine heat. EMPI does not warranty Exhaust Systems against discoloration or bluing.



# EXHAUST COMPONENTS

## GT STYLE EXHAUST SYSTEMS

European looks with Muffler featuring 1 or 2 Chrome Exhaust Tips. Complete with hardware and aluminum flex hose.

### EMPI 2 TIP EXHAUST SYSTEM

**3418** Type 1 & Ghia, 1300-1600cc, 66-73  
Black with Chrome Tips

**55-3418** Type 1 & Ghia, 1300-1600cc, 66-73  
**Ceramic Coated**



### 2 TIP GT EXHAUST SYSTEM

**3766** **NEW!** Type 1, 1200cc, 63 1/2-65 (40HP)  
Black with Chrome Tips

**3417** Type 1 & Ghia, 1300-1600cc, 66-73  
Black with Chrome Tips

### SINGLE-TIP GT EXHAUST SYSTEM

**3487** Type 1 & Ghia, 1300-1600cc, 66-73  
Type 2, 63-71  
Black with Chrome Tip



## SQUARE -TIP EXHAUST SYSTEMS

All new 2-Tip GT Exhaust system featuring 1 3/8" tubing and Dual Chrome Square tips that exit thru the stock apron cut-outs. Complete with hardware and aluminum flex hose.

**3675** Square-Tip Exhaust, Black w/ Chrome Square Tips  
Type 1 & Ghia, 1300-1600cc, 66-73



EMPI Headers and Mufflers are coated with a layer of paint which acts as a rust inhibitor - and may burn off once they get hot. It is best to clean off the coating with a good solvent then paint the system with quality hi-temp paint. Systems are not warranted against rust. EMPI offers many Exhaust Systems pre-finished in a Ceramic Coating. Discoloration is not a manufacturing, **chrome** process or **stainless steel** issue. High exhaust temperatures exceed the capabilities of chrome plating to handle the heat without discoloration. Stainless Steel systems may also experience discoloration due to engine heat. EMPI does not warranty Exhaust Systems against discoloration or bluing.



## 'PEA SHOOTER' EXHAUST SYSTEM

All new 2-Tip Pea Shooter Exhaust system featuring 1 3/8" tubing and Dual Chrome 'Pea Shooter' tips with baffles that exit thru the stock apron cut-outs. Complete with hardware and aluminum flex hose.

**3680** Pea Shooter Exhaust System - Black w/ Chrome 'Pea Shooter' Tips  
Type 1 & Ghia, 1300-1600cc, 66-73

## 4-TIP GT EXHAUST SYSTEM

European looks with Quiet Muffler featuring 4 Chrome Exhaust Tips with built-in resonators for that unique "GT" sound. Complete with hardware and aluminum flex hose.



**3414** Type 1 & Ghia, 1300-1600cc, 66-73  
Type 2, 63-71  
Black with Chrome Tips

**3415** **NEW!** Type 3, 1300-1600cc, Black with Chrome Tips



## SIDEFLOW EXHAUST SYSTEM

1 1/2" tubing featuring a true 4 into 1 merged collector. Tig welded for strength and good looks. System includes black Quiet Muffler w/ **Stainless Steel** Tip. Complete with gaskets and hardware. Type 1 upright engines only.

**3485** **NEW!** Sideflow Merged Exhaust System w/ Muffler,  
Type 1 Upright Engines Only



This is a competition system and cannot be used with heater boxes.

EMPI Headers and Mufflers are coated with a layer of paint which acts as a rust inhibitor - and may burn off once they get hot. It is best to clean off the coating with a good solvent then paint the system with quality hi-temp paint. Systems are not warranted against rust. EMPI offers many Exhaust Systems pre-finished in a Ceramic Coating. Discoloration is not a manufacturing, **chrome** process or **stainless steel** issue. High exhaust temperatures exceed the capabilities of chrome plating to handle the heat without discoloration. Stainless Steel systems may also experience discoloration due to engine heat. EMPI does not warranty Exhaust Systems against discoloration or bluing.





# EXHAUST COMPONENTS

## COMPETITION MERGED EXHAUST SYSTEM

This is the exhaust system for the serious racer. A true merged exhaust. Four 1 5/8" large diameter mandrel bent tubes are cut and fitted into a long merged collector. Header features thick H.D. Flanges with ground flat gasket surfaces. All internal welds are ground for true high flow performance. Includes an EMPI swivel flange racing stinger. Use the hideaway muffler or PHAT Boy to get to & from the track. Eliminates heater boxes. [Type 1 only.](#)

**3699** 1 5/8" Racing Merged Exhaust Sys., Eliminates Heater Boxes  
**55-3699** 1 5/8" Racing Merged Exhaust System, Eliminates Heater Boxes, **Ceramic Coated**

**3689** **NEW!** Dual Quiet Muffler Only for 3699 and 7320 

**3700** Hideaway Muffler - Fits P/N: 3699 & 7320, with J-Tubes   
**55-3700** Hideaway Muffler - Fits P/N: 3699 & 7320, with J-Tubes   
**Ceramic Coated**

## COMPETITION MERGED EXHAUST FOR BOLT-ON HEATER BOXES

EMPI now offers an 1 5/8" Merged Competition Header System for use with special 1 1/2" flanged racing heater boxes. This enables you to have a defroster/heater system and still have a hi-performance merged exhaust system. Header features thick H.D. Flanges with ground flat gasket surfaces. All internal welds are ground for true high flow performance. Headers are supplied with an EMPI swivel flange racing stinger. Heater boxes have lightweight inner coils to still generate good heater output while 1 1/2" tubing allows for less restriction on your hi-performance motor! Header system is provided with a stinger. Then choose from heater boxes or 1 5/8" J-tubes to complete your installation. All components are available also with a ceramic coat finish instead of painted. In addition you can use the hideaway muffler or PHAT Boy to get to & from the track. [Type 1 only. Header & Stinger ONLY.](#)

### 1 5/8" MERGE HEADER ONLY W/STINGER

**7320** 1 5/8" Merged Flanged Header Only w/Stinger  
**55-7320** 1 5/8" Merged Flanged Header Only w/Stinger, **Ceramic Coated**

### 1 5/8" FLANGED J-TUBE FOR P/N: 7320 / 55-7320

**3422** 1 5/8" J-Tubes for Merged Header, Pair  
**55-3422** 1 5/8" J-Tubes for Merged Header, Pair, **Ceramic Coated**

### 1 1/2" FLANGED HEATER BOXES FOR P/N: 7320 / 55-7320

**95-3028-B** Hi-Performance 1 1/2" Flanged Heater Box, Left  
**55-3028** Hi-Perf. 1 1/2" Flanged Heater Box, Left, **Ceramic Coated**

**95-3029-B** Hi-Performance 1 1/2" Flanged Heater Box, Right  
**55-3029** Hi-Perf. 1 1/2" Flanged Heater Box, Right, **Ceramic Coated**

## PHAT BOY MUFFLERS FOR MERGED EXHAUST

These merged PHAT boys provide maximum flow and power with a distinctive turbo hush. They won't see you coming; they will hear you going. We make 3 versions, black, ceramic coated steel and stainless steel. [Type 1 only.](#)

**3701** PHAT Boy Muffler, Black - Fits P/N: 3699  
**3702** PHAT Boy Muffler, **Ceramic Coated** - Fits P/N: 3699  
**3703** PHAT Boy Muffler, **Stainless Steel** - Fits P/N: 3699 / 7320 / 55-7320



3699



**NEW!**

3689



3700



7320  
(Header & Stinger)



Available with  
**Ceramic Coating**



Available with  
**Ceramic Coating**

3422



3701



3703

**STAINLESS  
STEEL**

EMPI Headers and Mufflers are coated with a layer of paint which acts as a rust inhibitor - and may burn off once they get hot. It is best to clean off the coating with a good solvent then paint the system with quality hi-temp paint. Systems are not warranted against rust. EMPI offers many Exhaust Systems pre-finished in a Ceramic Coating. Discoloration is not a manufacturing, **chrome** process or **stainless steel** issue. High exhaust temperatures exceed the capabilities of chrome plating to handle the heat without discoloration. Stainless Steel systems may also experience discoloration due to engine heat. EMPI does not warranty Exhaust Systems against discoloration or bluing.

## NEW STAINLESS STEEL EXHAUST SYSTEMS

### STAINLESS STEEL EXTRACTOR AND MUFFLERS

#### STAINLESS STEEL EXTRACTOR & STINGER

Stainless Steel 1 3/8" tubing, Tig welded with thick mounting flanges - fully welded internally. The 3-bolt muffler flange is centered, flange is at the 1:00 position and features oval holes for muffler alignment. May be used with heater boxes or J-Pipes. Complete with aluminum flex hose, gaskets and hardware.

**3767** S/S Extractor, Fits Type 1 & 2, 1300-1600 Upright Engines

**3477** **NEW!** S/S Stinger Only w/ Swivel Flange. Fits 3100 / 3102 / 3767



#### STAINLESS STEEL PHAT BOY MUFFLER

Stainless Steel Phat Boy Muffler for P/N 3767 Extractor, includes gasket and hardware. Will only fit 3767 Header.

**3765** S/S Phat Boy Muffler for P/N 3767 Extractor Fits Type 1 1300-1600 Upright Engines

**3206** **NEW!** S/S Phat Boy Muffler for P/N 3767 Extractor Fits Type 2 1500-1600 Upright Engines



#### STAINLESS STEEL HIDEAWAY MUFFLER

Stainless Steel Hideaway Muffler for P/N 3767 Extractor. Includes brackets, hardware and gasket.

**3763** S/S Hideaway Muffler for P/N 3767 Extractor Fits Bug 1300-1600 Upright Engine Will fit 3767 and 3100 Headers



#### STAINLESS STEEL J-TUBES

1 1/2" Stainless Steel Tubing J-Tubes, Tig welded with thick mounting flanges, fully welded internally. Will fit most standard extractors. Fits all Type 1 & 2 upright engines. Complete with gaskets. Will fit all EMPI Exhaust.

**3768** S/S J-Tubes, Pair, Fits all Type 1 & 2 Upright Engines

Discoloration is not a manufacturing, **chrome** process or **stainless steel** issue. High exhaust temperatures exceed the capabilities of chrome plating to handle the heat without discoloration. Stainless Steel systems may also experience discoloration due to engine heat. EMPI does not warranty Exhaust Systems against discoloration or bluing.





# EXHAUST COMPONENTS

## STAINLESS STEEL MERGED COMPETITION EXHAUST SYSTEMS

1 5/8" Stainless Steel tubing, tig welded for strength and good looks and features a true 4 into 1 merged collector. The mounting flanges are thick and fully welded internally. Includes Stainless Steel Stinger w/ Swivel Flange. Complete with gaskets and hardware.

This is a competition system and cannot be used with heater boxes.



3760  
Exhaust w/ Stinger



3760

S/S Merged Competition Exhaust System w/ Stinger, Type 1 Only

3703

S/S Phat Boy Muffler for Merged Exhaust

3772

S/S Stinger Only w/ Swivel Flange Will fit 3760, 3682, 3699 and 7320 Headers

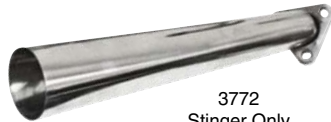

3772  
Stinger Only



3703



Thick Flanges

## STAINLESS STEEL SIDEFLOW EXHAUST SYSTEMS

Stainless Steel 1 5/8" tubing featuring a true 4 into 1 merged collector. Tig welded for strength and good looks. The mounting flanges are thick and fully welded internally. System includes S/S Quiet Muffler. Complete with gaskets and hardware.

This is a competition system and cannot be used with heater boxes.

3762

S/S Sideflow Merged Exhaust System w/ Muffler, Type 1 Upright Engines Only



3762



3761

## STAINLESS STEEL 2-TIP EXHAUST SYSTEM

Stainless Steel Exhaust System— precision-designed with 2 Chrome Baffled Tips that exit thru the stock apron cut-outs. Features thick flanges for secure fit and seal. 1 3/8" S/S Tubing. Includes aluminum flex hose, gaskets and hardware.

3761

Stainless Steel 2-Tip Exhaust, Type 1 1300-1600, Type 1 & Ghia, 1300-1600cc, 66-73

## STAINLESS STEEL LATE TYPE 2 & TYPE 4 EXHAUST SYSTEM

1 1/2" Stainless Steel Tubing, Tig welded with thick mounting flanges. Fully welded internally w/ S/S quiet muffler. Complete with gaskets and hardware.

3771

S/S Type 2 & 411, 72-74, Engine 1700-2000cc



3771

Discoloration is not a manufacturing, chrome process or stainless steel issue. High exhaust temperatures exceed the capabilities of chrome plating to handle the heat without discoloration. Stainless Steel systems may also experience discoloration due to engine heat. EMPI does not warranty Exhaust Systems against discoloration or bluing.

## BAJA EXHAUST SYSTEMS

Our Baja Systems feature 1 1/2" tubing and provide excellent ground clearance and increased horsepower. Available with Quiet Muffler or Stinger and for use with or without heater. All are Large 3 Bolt Flange and come complete with hardware. Systems with heater include aluminum flex hose. Fits 1300-1600cc. Systems without heater require the use of J-Tubes. Systems that eliminate heater boxes bolt directly to heads.

### BAJA EXHAUST SYSTEM - SINGLE QUIET MUFFLER

- 3368** Baja System, Eliminates Heater Boxes
- 3369** Baja System, w/Heater (Incl. Alum. Flex Hose)

### BAJA EXHAUST SYSTEM - W/LONG CHROME OR BLACK STINGER

- 3732** Baja System, Black Stinger, Eliminates Heater Boxes
- 3730** Baja System, Black Stinger, w/Heater (Incl. Alum. Flex Hose)
- 3743** Baja System, Chrome Stinger, Eliminates Heater Boxes
- 3741** Baja System, Chrome Stinger, w/Heater (Incl. Alum. Flex Hose)

### BAJA HEADER ONLY

- 3466** Header Only, Eliminates Heater Boxes - Fits P/N: 3366/3368
- 55-3466** Header Only, Eliminates Heater Boxes, **Ceramic Coated**, Fits 3368
- 3467** Header Only, w/Heater - Fits 3369 (Includes Alum. Flex Hose)
- 55-3467** Header Only, w/Heater, **Ceramic Coated** - Fits 3369 (Includes Alum. Flex Hose)

### BAJA REPLACEMENT MUFFLERS

- 3340** Quiet Muffler w/o Bend, Black
- 55-3340** Quiet Muffler w/o Bend, **Ceramic Coated**
- 3468** Pipe Bend, Black, Connects Muffler to Header, Fits P/N: 3340
- 55-3468** Pipe Bend, **Ceramic Coated**, Connects Muffler to Header, Fits P/N: 55-3340

### BAJA STINGERS & BAFFLES WITH LARGE 3 BOLT FLANGE

- 3377** Long Stinger, Chrome
- 3382** Long Stinger, Black
- 55-3382** Long Stinger, **Ceramic Coated**
- 3780-1** Baffle, Fiberglass Wrapped



EMPI Headers and Mufflers are coated with a layer of paint which acts as a rust inhibitor - and may burn off once they get hot. It is best to clean off the coating with a good solvent then paint the system with quality hi-temp paint. Systems are not warranted against rust. EMPI offers many Exhaust Systems pre-finished in a Ceramic Coating. Discoloration is not a manufacturing, **chrome** process or **stainless steel** issue. High exhaust temperatures exceed the capabilities of chrome plating to handle the heat without discoloration. Stainless Steel systems may also experience discoloration due to engine heat. EMPI does not warranty Exhaust Systems against discoloration or bluing.



# EXHAUST COMPONENTS

## OFF-ROAD COMPETITION EXHAUST SYSTEMS

Competition-Proven, these systems are designed for maximum horsepower and built to take the punishment of off-road competition. Features a merged, spring-attached collector and are available in 1 1/2" or 1 5/8" tubing. Choose Chrome, Black or Ceramic Coated finish. Available with straight or U-bend stingers. Our Turbo Muffler Kit is sold separately for street or controlled area use. Turbo Muffler Kit supplied with Collector. All systems eliminate heater boxes. Fits 1300-1600cc Type 1 based engines.

3455 Comp Exhaust, 1 1/2" w/Straight Stinger, Black  
 55-3455 Comp Exhaust, 1 1/2" w/Straight Stinger, **Ceramic Coated**  
 3458 Comp Exhaust, 1 1/2" w/Straight Stinger, Chrome

3456 Comp Exhaust, 1 5/8" w/Straight Stinger, Black  
 55-3456 Comp Exhaust, 1 5/8" w/Straight Stinger, **Ceramic Coated**  
 3459 Comp Exhaust, 1 5/8" w/Straight Stinger, Chrome

3460 Comp Exhaust, 1 1/2" w/U-Bend Stinger, Black  
 55-3460 Comp Exhaust, 1 1/2" w/U-Bend Stinger, **Ceramic Coated**  
 3462 Comp Exhaust, 1 1/2" w/U-Bend Stinger, Chrome

3461 Comp Exhaust, 1 5/8" w/U-Bend Stinger, Black  
 55-3461 Comp Exhaust, 1 5/8" w/U-Bend Stinger, **Ceramic Coated**  
 3463 Comp Exhaust, 1 5/8" w/U-Bend Stinger, Chrome

3745 Comp Exhaust, 1 1/2" w/Turbo Muffler, Black  
 55-3745 Comp Exhaust, 1 1/2" w/Turbo Muffler, **Ceramic Coated**

3746 Comp Exhaust, 1 5/8" w/Turbo Muffler, Black  
 55-3746 Comp Exhaust, 1 5/8" w/Turbo Muffler, **Ceramic Coated**

3453 1 1/2" U-Bend Collector Only, Black  
 3454 1 1/2" U-Bend Collector Only, Chrome  
 55-3453 1 1/2" U-Bend Collector Only, **Ceramic Coated**

3451 1 5/8" U-Bend Collector Only, Black  
 3452 1 5/8" U-Bend Collector Only, Chrome  
 55-3451 1 5/8" U-Bend Collector Only, **Ceramic Coated**

3465 Turbo Muffler Kit, 1 1/2", Black - Fits P/N: 3455/3458

3469 Turbo Muffler Kit, 1 5/8", Black - Fits P/N: 3456/3459

3475-1 Fiberglass Wrapped Baffle for Straight Stingers  
 3476 Replacement Springs, Set of 4



EMPI Headers and Mufflers are coated with a layer of paint which acts as a rust inhibitor - and may burn off once they get hot. It is best to clean off the coating with a good solvent then paint the system with quality hi-temp paint. Systems are not warranted against rust. EMPI offers many Exhaust Systems pre-finished in a Ceramic Coating. Discoloration is not a manufacturing, **chrome** process or **stainless steel** issue. High exhaust temperatures exceed the capabilities of chrome plating to handle the heat without discoloration. Stainless Steel systems may also experience discoloration due to engine heat. EMPI does not warranty Exhaust Systems against discoloration or bluing.

## STAINLESS STEEL OFF-ROAD COMPETITION EXHAUST SYSTEMS

Built to take the punishment of off-road competition and beat the elements with all Stainless Steel construction. Features a merged, spring-attached collector, thick stainless steel flanges and is available in either 1 1/2" or 1 5/8" Stainless Steel tubing. All systems eliminate heater boxes. Fits 1300-1600cc Type 1 based engines.



56-3458 / 56-3459

**56-3458** **NEW!** EMPI 1 1/2" **Stainless Steel** Off-Road Competition Exhaust System w/ Classic Vertical Stinger

**56-3459** **NEW!** EMPI 1 5/8" **Stainless Steel** Off-Road Competition Exhaust System w/ Classic Vertical Stinger



56-3462 / 56-3463

**56-3462** **NEW!** EMPI 1 1/2" **Stainless Steel** Off-Road Competition Exhaust Systems w/ Down-Turn Stinger

**56-3463** **NEW!** EMPI 1 5/8" **Stainless Steel** Off-Road Competition Exhaust Systems w/ Down-Turn Stinger



56-3752 / 56-3753

**56-3752** **NEW!** EMPI 1 1/2" **Stainless Steel** Off-Road Competition Exhaust Systems w/ Stainless Steel Racing Muffler

**56-3753** **NEW!** EMPI 1 5/8" **Stainless Steel** Off-Road Competition Exhaust Systems w/ Stainless Steel Racing Muffler

## STAINLESS STEEL DUAL RACING EXHAUST SYSTEMS

Dual style exhaust features great looks and maximum horsepower. Slip-joints allow for easy installation. Available with or without Muffler Inserts. Eliminates heater boxes. Fits 1200-1600cc engines with most single or dual carburetors except 48's, 51's and EPC 34's.



**56-3709** **NEW!** S/S Dual Racing System w/ Inserts

**56-3759** **NEW!** S/S Dual Racing System w/o Inserts

**3721** Replacement Muffler Inserts, Each

## STAINLESS STEEL 4 PIPE STINGER EXHAUST

Commonly known as "Power Pipes" this exhaust provides a unique sound. Used when rear of car doesn't permit conventional exhaust to be installed. Also available are muffler inserts when noise is not desirable.



18-1047

**18-1047** **NEW!** S/S 4 Pipe Stinger Exhaust

**B253900** **NEW!** Muffler Insert for 18-1047, Each



**NEW!**

B253900

Discoloration is not a manufacturing, **chrome** process or **stainless steel** issue. High exhaust temperatures exceed the capabilities of chrome plating to handle the heat without discoloration. Stainless Steel systems may also experience discoloration due to engine heat. EMPI does not warranty Exhaust Systems against discoloration or bluing.



# EXHAUST COMPONENTS

## SIDE-EXIT OFF-ROAD MERGED EXHAUST

Side-Exit style with our proven 4 into 1 collector with open exhaust exiting to the passenger side. Features 1 5/8" Tig welded steel tubing with thick mounting flanges. Includes hardware, gaskets and springs. For use without heater boxes only. Available in black paint or Ceramic Coated Silver.

- 3470 **NEW!** 1 5/8" Side-Exit Off-Road Exhaust, Black
- 55-3470 **NEW!** 1 5/8" Side-Exit Off-Road Exhaust, Ceramic Coated



## OFF-ROAD COMPETITION EXHAUST W/ DUAL QUIET MUFFLERS

Same Competition-Proven Exhaust with Dual Quiet Mufflers in your choice of 1 1/2" or 1 5/8" Tube size. Features a merged, spring-attached collector and includes gaskets, clamps & hardware. Eliminates heater boxes, Type 1 only.

- 3480 **NEW!** Big Engine Exhaust System w/Dual Quiet Mufflers, 1 1/2", Black
- 3479 **NEW!** Big Engine Exhaust System w/Dual Quiet Mufflers, 1 5/8", Black
- 3478 **NEW!** Replacement Dual Quiet Mufflers, Black   
Fits 3471, 3479 & 3480 Exhaust Headers  
Includes Gaskets. Clamps & Hardware



## BIG ENGINE EXHAUST

Long Stroke, Long Rods and Spacers make for wider engines which require an exhaust system that can accommodate the wide build. This newly designed Competition System is designed with slip joints for fitting even the widest engines. Made with 1 5/8" tubing, merged collector and built for maximum horsepower. Works great on standard width engines as well.

Accepts EMPI Baffle P/N 3475-1.

- 3471 **NEW!** Big Engine Exhaust System, 1 5/8", Black
- 3475-1 Fiberglass Wrapped Baffle, Each



## DESERT DUELER EXHAUST

Finally a Competition System designed for maximum horsepower and built to take the punishment of off-road competition but made with 1 3/8" tubing for smaller displacement engines. Exits Down with U-Bend and Long Stinger with support brace.

Accepts EMPI Baffle P/N 3780-1.

- 3786 **NEW!** Desert Dueler Exhaust System, 1 3/8" w/U-Bend Long Stinger, Black
- 3780-1 Fiberglass Wrapped Baffle, Each



## LOW DUAL ZOOM EXHAUST SYSTEM

Zoom duals are designed for use in vehicles utilizing the stock heater boxes, such as Baja Bugs, Dune Buggies, etc. The racy zoom glass pack mufflers are beautifully chromed for that special look. Was specifically designed to accommodate the kit car and full body dune buggy applications. Comes complete with all necessary hardware including sufficient hose for installations of heater pipes. Fits 63 and later models only.

- 18-1048 **NEW!** Low Dual Zooms W/Chrome Mufflers



EMPI Headers and Mufflers are coated with a layer of paint which acts as a rust inhibitor - and may burn off once they get hot. It is best to clean off the coating with a good solvent then paint the system with quality hi-temp paint. Systems are not warranted against rust. EMPI offers many Exhaust Systems pre-finished in a Ceramic Coating. Discoloration is not a manufacturing, chrome process or stainless steel issue. High exhaust temperatures exceed the capabilities of chrome plating to handle the heat without discoloration. Stainless Steel systems may also experience discoloration due to engine heat. EMPI does not warranty Exhaust Systems against discoloration or bluing.

# EXHAUST COMPONENTS



## RACING MUFFLER FOR OFF-ROAD COMP. EXHAUST SYSTEMS

**Stainless Steel**

This great looking **Stainless Steel** Muffler offers quieter operation without sacrificing performance, thanks to its unrestricted flow through design. Comes complete with Special Down Pipe and Heavy Duty Stainless Mounting Clamps. Easily adapts to any upswept exhaust system with a 2" O.D. stinger pipe (Cut to fit, no welding required). Components can also be purchased separately to aid in making your own custom exhaust system.

- 3782 Racing Muffler Complete Assembly
- 3783 Racing Muffler Only, w/Mounting Clamps
- 3784 Racing Muffler Replacement Mounting Clamps Only
- 3785 Repl. Chrome Down Tube and Clamp for P/N: 3782/3783

### Tip:

The P/N: 3735 spark arrestor can be welded to the end of our stainless steel racing muffler to enable you to have a spark arrestor style racing exhaust!

## OFF-ROAD COMPETITION EXHAUST SYSTEMS WITH STAINLESS STEEL RACING MUFFLER

Take an outstanding Off-Road Exhaust and add a **Stainless Steel** Muffler to it. The Best just got Better! Utilizing elements of the EMPI **Stainless Steel** Muffler and adding it to our existing Competition Exhaust Systems gives you the ability to bring down the decibels to a decent level and raise the performance and appearance of any ride. EMPI has these systems available in 1 1/2" & 1 5/8" diameters for whichever performance level you require. Choose from Black, Chrome or Ceramic Coated exhaust pipes. Eliminates heater boxes.



Available with Ceramic Coating

- 3750 Comp Exhaust, 1 1/2", Black, w/**Stainless** Off-Road Muffler
- 55-3750 Comp Exhaust, 1 1/2", **Ceramic Coated**, w/**Stainless** Off-Road Muffler
- 3752 Comp Exhaust, 1 1/2", Chrome, w/**Stainless** Off-Road Muffler

- 3751 Comp Exhaust, 1 5/8", Black, w/**Stainless** Off-Road Muffler
- 55-3751 Comp Exhaust, 1 5/8", **Ceramic Coated**, w/**Stainless** Off-Road Muffler
- 3753 Comp Exhaust, 1 5/8", Chrome, w/**Stainless** Off-Road Muffler

## EMPI SPARK ARRESTORS

Many off-road areas now require some form of a spark arrestor to limit the chance of fires. EMPI now has a variety of spark arrestor assemblies to choose from. The 3" & 4" disc kits are for clamp on or weld on installation. The 10" & 17" mufflers are **Stainless Steel** outer shells with 4" discs for fine tuning of your exhaust restriction. All of the assemblies come with long enough screws to add additional discs if your horsepower needs dictate it. The 10" muffler is also available with & without a mounting bracket so you can custom fit it to an existing exhaust system if you so choose.

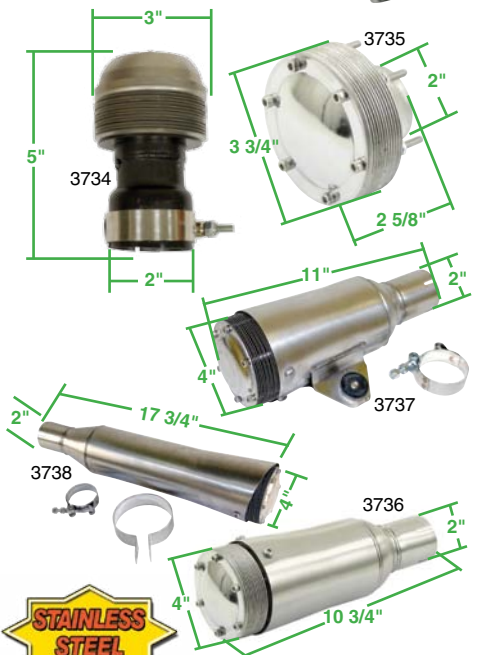

- 3734 Spark Arrestor, 2" Slip-On, 3" Discs
- 3735 Spark Arrestor, 2" Weld-On, 4" Discs
- 3737 Spark Arrestor, 10" **S/S** Muffler w/Mount, 4" Discs
- 3736 Spark Arrestor, 10" **S/S** Muffler w/o Mount, 4" Discs
- 3738 Spark Arrestor, 17" **S/S** Muffler w/o Mount, 4" Discs
- 3739 4" **S/S** Discs Only, 6 pcs.
- 3740 Replacement **S/S** End Cap Bolts, 6 pcs.

**STAINLESS STEEL**

EMPI Headers and Mufflers are coated with a layer of paint which acts as a rust inhibitor - and may burn off once they get hot. It is best to clean off the coating with a good solvent then paint the system with quality hi-temp paint. Systems are not warranted against rust. EMPI offers many Exhaust Systems pre-finished in a Ceramic Coating. Discoloration is not a manufacturing, **chrome** process or **stainless steel** issue. High exhaust temperatures exceed the capabilities of chrome plating to handle the heat without discoloration. **Stainless Steel** systems may also experience discoloration due to engine heat. EMPI does not warranty Exhaust Systems against discoloration or bluing.



# EXHAUST COMPONENTS

## BUGGY DUAL EXHAUSTS

Due to popular demand, we took our most popular dual buggy exhaust system and redesigned it to be compatible with **any** of our dual carburetor systems. Available in black with chrome tips or ceramic coated. For 1200-1600cc.

- 3373 Buggy Dual Exhaust Black with Chrome Tips, w/o Heater Box
- 55-3373 Buggy Dual Exhaust, w/o Heater Box, **Ceramic Coated**



## DUAL RACING EXHAUST SYSTEMS

Dual style exhaust features great looks and maximum horsepower. Slip-joints allow for easy installation. Available in chrome, black, ceramic coated or now stainless steel. With or without Muffler Inserts. Eliminates heater boxes. Fits 1200-1600cc engines with most single or dual carburetors except 48's, 51's and EPC 34's.

- 3708 Dual Racing System w/Inserts, Black
- 55-3708 Dual Racing System w/Inserts, **Ceramic Coated**
- 3709 Dual Racing System w/Inserts, Chrome
- 3758 Dual Racing System w/o Inserts, Black
- 3759 Dual Racing System w/o Inserts, Chrome
- 56-3709 **NEW!** Dual Racing System w/ Inserts, **Stainless Steel**
- 56-3759 **NEW!** Dual Racing System w/o Inserts, **Stainless Steel**
- 3721 Replacement Muffler Inserts, Each



## DUAL EXHAUST SYSTEMS

The original "Dune Buggy Duals" feature dual Glass Pack Mufflers with Chrome Tips. Fits 1200-1600cc engines with single carburetor. Must use stock style clip on valve covers. Tight fitting to engine for optimum frame clearance.

- 3376 Dual Exhaust Black with Chrome Tips - w/o Heater Box
- 55-3376 Dual Exhaust - w/o Heater Box, **Ceramic Coated**



## CHROME EXHAUST DUAL-TIPS

Chrome Dual Tips without spiral fiberglass core resonators. Easy to weld on, universal application. 1 5/8" I.D. inlet, 2 1/2" O.D. Chrome Tips, 13" overall length.

- 7308 Chrome Dual Tips - w/o Resonator



EMPI Headers and Mufflers are coated with a layer of paint which acts as a rust inhibitor - and may burn off once they get hot. It is best to clean off the coating with a good solvent then paint the system with quality hi-temp paint. Systems are not warranted against rust. EMPI offers many Exhaust Systems pre-finished in a Ceramic Coating. Discoloration is not a manufacturing, **chrome** process or **stainless steel** issue. High exhaust temperatures exceed the capabilities of chrome plating to handle the heat without discoloration. Stainless Steel systems may also experience discoloration due to engine heat. EMPI does not warranty Exhaust Systems against discoloration or bluing.



95-3003-B

## EURO-MADE STOCK REPLACEMENT MUFFLERS

Looking for a high quality, European-Made replacement muffler? This is the one. With attention to OEM details...pre-heater boxes, muffler seam, exhaust tip supports...all OEM quality.

**95-3003-B** Euro-Made Stock Replacement Muffler Type 1, 1300-1600cc  
(Ref. P/N: 113 251 053AKEU)



95-3002-B

**95-3002-B** Euro-Made Stock Replacement Muffler Type 1, 40HP/1200cc  
(Ref. P/N: 111 251 051H)



95-3004-B

**95-3004-B** Euro-Made Stock Replacement Muffler Type 2, 1500-1600cc  
(Ref. P/N: 211 251 051E)



Euro-Made Mufflers



95-3013-B

**Dansk**



55-3012

## STOCK HEATER BOXES

Replace those rusted out and damaged heater boxes with European made Dansk Heavy Duty heater boxes. (Fits Type 1, 1300-1600cc Only).

**95-3012-B** Dansk H.D. Heater Box, Left  
(Ref. P/N: 043 255 107HD)

**55-3012** Dansk H.D. Heater Box, Left, **Ceramic Coated**

**95-3013-B** Dansk H.D. Heater Box, Right  
(Ref. P/N: 043 255 108HD)

**55-3013** Dansk H.D. Heater Box, Right, **Ceramic Coated**



55-3029

**Dansk**

## HI-PERFORMANCE 1 1/2" FLANGED HEATER BOXES

These heater boxes offer the ability to still use your heater/defrost system and not stifle your big motors H.P. output! Large I.D. tubing along with lightweight heater box design is the key to this equation. **Custom fit application to header P/N: 7320 and 55-7320 only.**

**95-3028-B** Hi-Performance 1 1/2" Flanged Heater Box, Left  
**55-3028** Hi-Perf. 1 1/2" Flanged Heater Box, Left, **Ceramic Coated**

**95-3029-B** Hi-Performance 1 1/2" Flanged Heater Box, Right  
**55-3029** Hi-Perf. 1 1/2" Flanged Heater Box, Right, **Ceramic Coated**

95-3028-B

## HEATER BOX LEVER KITS

EMPI heater box installation hardware kits are the best available. These kits have the proper fit and silver zinc finish to compliment your new heater boxes!

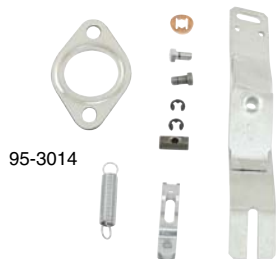

95-3014

**95-3014** Heater Box Lever Kit, Left  
(Bulk P/N: 043 298 147A)

**95-3015** Heater Box Lever Kit, Right  
(Bulk P/N: 043 298 148A)





# EXHAUST COMPONENTS

## CHROME TAIL PIPE KIT

Replacement Chrome tips for stock muffler. Kit includes 2 tips and 2 clamps.

**9915** Stock Tail Pipe Kit  
**9915-B** Bulk Tail Pipe Only, Each

(Ref. P/N: 113 251 163C)



## CHROME TAPERED / BAFFLED EXHAUST TIPS

Chrome Tapered Exhaust Tips feature internal baffles. Fits all stock mufflers.

**3693** Chrome Tapered/Baffled Tips, Pair  
**3693-B** Bulk Tapered/Baffled Tips, Each  
(Ref. P/N: 113 251 163TT)



## CHROME EXHAUST TIPS

Chrome Flared or Diagonal cut Exhaust Tips fit all stock mufflers.

**3362** Chrome Tips, Flared, Pair  
**3694** Chrome Tips, Diagonal Cut, Pair



## CHROME BAFFLED EXHAUST TIPS

Give your stock muffler a custom look and deeper sound with these "step" pipe exhaust tips. Angle cut extension features a baffled insert for a more "throaty" sound and the chrome plating adds in the looks department. Simply remove the stock "pea shooter" tips and install these replacements.

**16-9535** Chrome Tips, Pair



## CHEESE GRATER EXHAUST TIPS

Classic look fits over tail pipes on all stock Bug dual-tip mufflers.

**95-3050** Chrome Cheese Grater Tips



## CHROME ZOOM TUBE

Clamps on to stock Type 1 muffler and replaces stock exhaust tips. Chrome finish and Race-Style looks in minutes!

**3360** Chrome Zoom Tube



## EXHAUST INSTALLATION KITS

Includes all necessary gaskets, clamps, bolts and nuts for installation of stock muffler or exhaust system.



**98-2989** Muffler Inst. Kit, Type 1, 1200-1600cc

(Bulk P/N: 111 298 009F)

**3394** Tail Pipe Clamp Kit, Pair (Includes Exhaust Gaskets)

(Bulk P/N: 111 298 051, Clamp Kit Only, Each)

## EXHAUST / INTAKE NUT KITS

Choose from a wide variety of styles and materials.

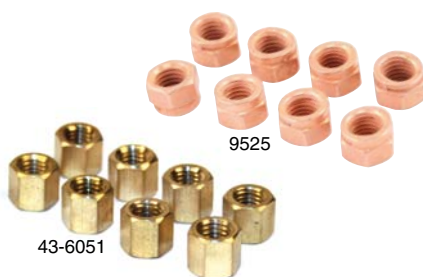

**9525** Exhaust Lock Nut Set, Copper, 8pcs.

**9525-B** Bulk Exh. Lock Nuts, Copper, Bag of 100

(Ref. P/N: 175 129 650)

**43-6051** Brass 8mm-1.25 thread, 11mm Head, Int./Exh. Nuts, Set of 8

**43-6051-B** Bulk Brass 8mm-1.25 thread, 11mm Head, Int./Exh. Nuts, Bag of 100

**NEW!**

**BUGPACK**

B250520

**B250520** **NEW!** HD Racing Exhaust Nuts, Steel Plated, Set of 8 8mm-1.25 Thread, 11mm Head

**17-2988** **NEW!** 12 Point 8mm Engine Nuts, 8 pcs

8mm-1.25 Thread, uses 10mm 12 Point Socket

**NEW!**

17-2988

## HEATER HOSE CONNECTOR PIPES

Fits like it's O.E.! These zinc plated pipes are what's needed to hook up your fan shroud heater hose to your stock muffler.



**98-1004** Heater Hose Connector Pipe to Stock Muffler, Pair

(Bulk P/N: 113 255 165, Each)

## HEATER BOX REPAIR PIPES

Repair heater box ends that have rusted or broken away (Zinc plated).



**9914** Heater Box Repair Pipes, Pair

(Bulk P/N: 113 255 107X, Each)



# EXHAUST COMPONENTS

## HEATER BOX J-TUBES

J-Tubes replace stock heater boxes, eliminating heater and saving weight. Fits most header systems and includes gaskets. Sold in pairs.

- 3357** All Up-Right Engines, Black, Skin Packed
- 55-3357** All Up-Right Engines, **Ceramic Coated**
- 3357-8** All Up-Right Engines, Black, Packaged in Poly Bag
  
- 3657** All Type 3 Models, Black, Skin Packed
- 3657-8** All Type 3 Models, Black, Packaged in Poly Bag
  
- 3420** All Up-Right Engines, w/Flanges, Black
- 55-3420** All Up-Right Engines, w/Flanges, **Ceramic Coated**



## HEATER BOX LEVER KITS

EMPI heater box installation hardware kits are the best available. These kits have the proper fit and silver zinc finish to compliment your new heater boxes!

- 95-3014** Heater Box Lever Kit, Left  
(Bulk P/N: 043 298 147A)
- 95-3015** Heater Box Lever Kit, Right  
(Bulk P/N: 043 298 148A)

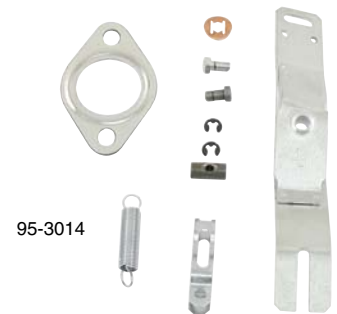

## HEAT RISER BLOCK-OFF PLATES

Covers heat riser flanges when intake heat riser is not used. A must when installing most dual carb kits. Available in Chrome or raw. Includes gaskets.

- 3447** Heat Riser Block-Off Plate Kit
- 17-2824** Chrome Heat Riser Block-Off Plate Kit



## FLANGE KIT FOR HEATER BOXES / J-TUBES

Kit includes flanges and premium hardware to convert one pair of heater boxes or J-tubes for use with flanged headers. Welding required. (Use P/N: 3511 flanges if needed, for header pipes).

- 3640** Exhaust Flange Conversion Kit for 1 3/8" Tubing

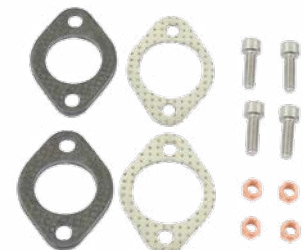

## ALUMINUM HEATER HOSE & CARB. PREHEATER HOSE

Manufactured from highly flexible aluminum. Contains no paper. Corrosion and flame resistant to 450°. Available in Bulk or packaged in Display Poly Bags. Sold each.



(Comes Bulk or Packaged in Poly Bag)

### BULK VW HEATER HOSE

- 3378** Type 1, 50mm x 1000mm, Each, 88 per Case  
(Ref. P/N: 028 129 087AL)  
**3705\*** Type 1, 50mm x 1000mm, **Black**, Each, 88 per Case  
(Ref. P/N: 028 129 087A)  
**3379** Type 3, 63mm x 1000mm, Each, 56 per Case  
(Ref. P/N: 616 211 29501)

\*Only this size is available in Black.

### BULK CARBURETOR PREHEATER HOSE

- 3488** 3/4" x 36", Each, 130 per Case  
**3489** 1" x 36", Each, 77 per Case  
**3490** 1 1/2" x 36", Each, 225 per Case  
**3491** 1 3/4" x 36", Each, 143 per Case



(Comes Bulk or Packaged in Poly Bag)

### PACKAGED VW HEATER HOSE (POLY BAGGED)

- 3494** Type 1, 50mm x 1000mm, Each  
**3706\*** Type 1, 50mm x 1000mm, **Black**, Each  
**3495** Type 3, 63mm x 1000mm, Each

\*Only this size is available in Black.

### PACKAGED CARB PREHEATER HOSE (POLY BAGGED)

- 3496** 3/4" x 36", Each  
**3497** 1" x 36", Each  
**3498** 1 1/2" x 36", Each  
**3499** 1 3/4" x 36", Each

### PLASTIC FRESH AIR PRE-HEATER HOSE

Fits between the Fan Shroud and the Upper factory Heater Connector.

- 98-2088** Plastic Fresh Air Pre-Heater Hose, 64 & Later Bug, Ghia, Bus, Thing, Pair  
(Bulk P/N: 113 255 292P, Each)



98-2088

### WARM AIR HOSE (BELLOWS) - HEAT EXCHANGER TO BODY

Get your heater functioning like new with these factory-styled insulated Warm Air Hoses. They install between the Heater Box and the Body. If you don't have the originals, be sure to measure the ends on the body and the heater box - then the length between the two.

- 98-2524-B** Warm Air Hose, 65 & Prior, 14" Long, 50/50mm, Each  
(Ref. P/N: 111 255 355B, Each)  
**98-2518-B** Warm Air Hose, 65 & Prior w/ 1600 Engine, 14.25" Long, 60/50mm, Each  
(Ref. P/N: 113 255 355C, Each)  
**98-2519-B** Warm Air Hose, 66-67, 15" Long, 60/64mm, Each  
(Ref. P/N: 113 255 355D, Each)  
**98-2520-B** Warm Air Hose, 68-72, 14" Long, 60/60mm, Each  
(Ref. P/N: 113 255 355M, Each)  
**98-2521-B** Warm Air Hose, 73-79, 17" Long, 60/60mm, Each  
(Ref. P/N: 043 255 355A, Each)



98-2524-B

98-2521-B

### STAINLESS STEEL HEATER HOSE CLAMPS

Clamps heater hose securely to fan housing and muffler pre-heater flange. Sold in sets of 4.

- 3380** S/S Heater Hose Clamps, Set of 4





# EXHAUST COMPONENTS

## SLIP-FLANGE EXHAUST FLANGE GASKETS

These **copper** exhaust flange gaskets are cutout to allow replacement of leaking gaskets without removing the header. The copper material makes gasket blow-outs a thing of the past.

- 3388 1 1/2" I.D. **Copper** Slip-Flange Exhaust Gaskets, Pack of 4
- 3389 1 5/8" I.D. **Copper** Slip-Flange Exhaust Gaskets, Pack of 4



## EXHAUST HARDWARE

A selection of the most popular Gaskets, Flanges & Hardware.

### Premium Hardware and Flange Kits

EMPI's Premium Exhaust Gaskets are **steel clad** to provide superior heat resistance and durability. **Stainless steel allen bolts** and **copper nuts** are included in premium kits with "hardware".

- 3636 Premium Small 3 Bolt Muffler Install. Kit w/Hardware
- 3637 Premium Header/Muffler Install. Kit, Gaskets & Hardware
- 3640 Heater Box/J-Tube Exhaust Flange Kit for 1 3/8" Tubing

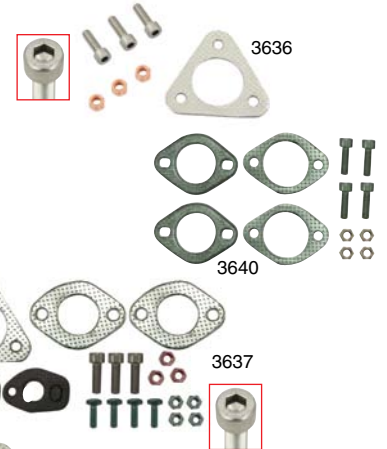

## GASKETS

- 3630 **Steel** Small 3 Bolt Muffler Flange Gasket, Each
- 3631 **Steel** 1200-1600cc Exhaust Port Gasket, 1 1/2" I.D., Pack of 4
- 3632 **Steel** 1200-1600cc Exhaust Port Gasket, 1 5/8" I.D., Pack of 4
- 17-2820 1200-1600cc **Copper** Exhaust Port Gaskets, 1 1/2" I.D., Pack of 4
- 17-2821 1200-1600cc **Copper** Exhaust Port Gaskets, 1 5/8" I.D., Pack of 4
- 3391 1200-1600cc Exhaust Port Gasket, 1 1/2" I.D., Pack of 4
- 3395 1200-1600cc Exhaust Port Gasket, 1 5/8" I.D., Pack of 4
- 3282 Type 2 & 4 Muffler Flange Gasket, 1.7, 1.8, 2.0L, Pk. of 2
- 3283 Type 2 & 4 Exhaust Flange Gasket, 75-78, Pk. of 2
- 3390 Large 3 Bolt Muffler Flange Gasket, Pack of 2
- 3393 Small 3 Bolt Muffler Flange Gasket, Pack of 2
- 3405 2 Bolt Muffler Flange Gasket, Pack of 2
- 3392 1200-1600cc Heat Riser Gasket, Pack of 4
- 98-2516-B Exhaust Flange Gasket Metal Clad, Type 1 50-79, Ghia 56-74, Type 2 50-71, Type 3 64-73, Each

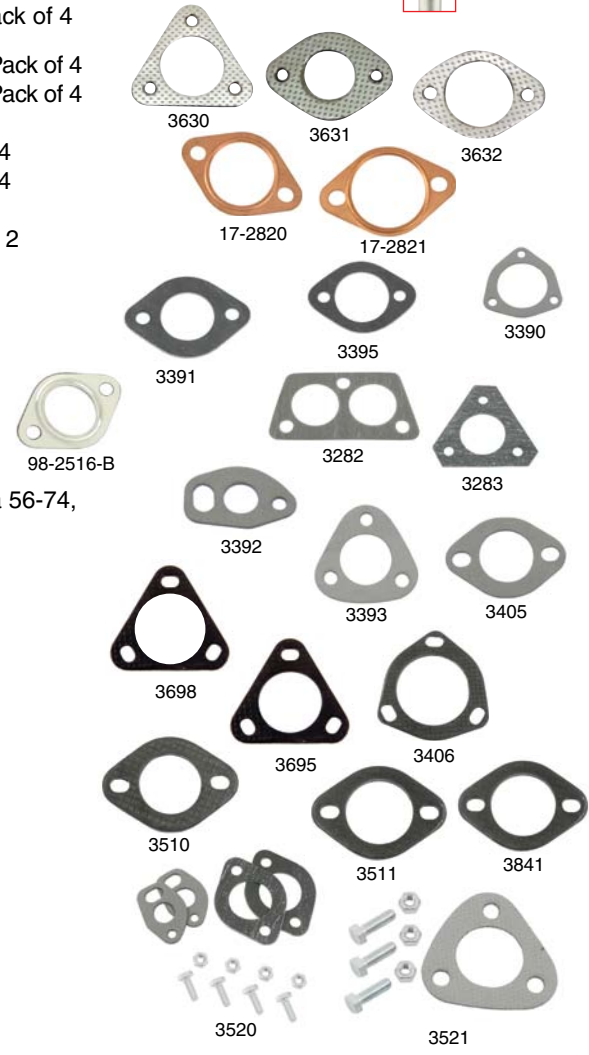

## STEEL FLANGES

- 3406 Large 3 Bolt Muffler Flange, 2 9/16" I.D., Pack of 1
- 3695 Small 3 Bolt Muffler Flange, 1 3/4" I.D., Pack of 1 (Slotted Holes)
- 3698 Small 3 Bolt Muffler Flange, 2" I.D., Pack of 1 (Slotted Holes)
- 3510 Exhaust Port Flange, 1 3/8" I.D., Pack of 2
- 3841 Exhaust Port Flange, 1 1/2" I.D., Pack of 2
- 3511 Exhaust Port Flange, 1 5/8" I.D., Pack of 2
- 3447 Heat Riser Block-Offs w/Gaskets, Pair

## STANDARD INSTALLATION KITS

- 3520 Header/Extractor Installation Kit - Poly Bag
- 3521 Small 3 Bolt Muffler Installation Kit - Poly Bag
- 3522 Large 3 Bolt Muffler Installation Kit - Poly Bag

**Note: Many Gaskets & Flanges are available in Bulk. Ask your sales person for assistance.**



## HEAVY DUTY CLUTCH KITS

Everything you need to replace your clutch in one handy kit. This quality kit includes a new **Sachs** pressure plate. Comes with disc, throw out bearing with clips, and a clutch alignment tool.

- 32-1256-B** Clutch Kit, 180mm (Boxed)  
(Ref. P/N: 211 141 025DK)
- 32-1258-B** Clutch Kit, 200mm, Early Style (Boxed)  
(Ref. P/N: 311 141 025EK)
- 32-1257-B** Clutch Kit, 200mm, Late Style (Boxed)  
(Ref. P/N: 311 141 025CK)

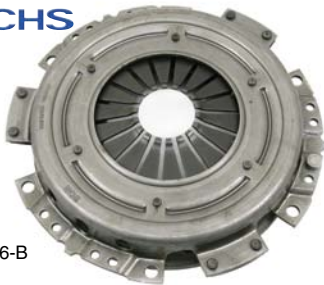

32-1236-B

## HEAVY DUTY PRESSURE PLATE

These Heavy Duty **Sachs** Pressure Plates offer strong and smooth clutch operation and improved Spring pressure over stock. Available in 180 or 200mm.

- 32-1234-B** H.D. Pressure Plate, 180mm (Boxed)  
(Ref. P/N: 211 141 025DBR)
- 32-1235-B** H.D. Pressure Plate, 200mm, thru 70 (Boxed)  
(Ref. P/N: 311 141 025EBR)
- 32-1236-B** H.D. Pressure Plate, 200mm, 71 on (Boxed)  
(Ref. P/N: 311 141 025CBR)

32-1241-B



32-1242-B

32-1243-B

## REPLACEMENT PRESSURE PLATES

Quality replacement pressure plates available in both 180 & 200mm.

- 32-1241-B** Replacement Pressure Plate, 180mm  
(Ref. P/N: 211 141 025DCH)
- 32-1242-B** Replacement Pressure Plate, 200mm, thru 70  
(Ref. P/N: 311 141 025ECH)
- 32-1243-B** Replacement Pressure Plate, 200mm, 71 & Later  
(Ref. P/N: 311 141 025CCH)

## HEAVY DUTY CLUTCH DISC

Features the latest in friction materials. Available in 180 or 200mm. A perfect match for our H.D. Pressure Plate.



32-1245

32-1250

- 32-1240** H.D. Disc, 180mm - Rigid Hub  
(Bulk P/N: 111 141 031EK)
- 32-1245** H.D. Disc, 200mm - Rigid Hub  
(Bulk P/N: 311 141 031BK)
- 32-1250** H.D. Disc, 200mm - Spring Hub  
(Bulk P/N: 311 141 031DK)



# CLUTCH & TRANSMISSION

## EMPI PERFORMANCE CLUTCHES

The latest addition to the EMPI high performance line. Perfect for drag race, sand/off-road or high performance street applications. These 200mm pressure plates are rated at 1700lbs and 2100lbs, and are factory balanced with the removable center ring to cover both early and late transmissions.

- 4080 EMPI 1700lb. Pressure Plate (Boxed)
- 4082 EMPI 2100lb. Pressure Plate (Boxed)



4080

## K.E.P. PERFORMANCE CLUTCHES

Kennedy Clutches have long been relied on in Drag Racing, Off-Road and Sand competition - as well as performance street applications. Center ring is removable for all late model style applications.

- 4090 K.E.P. Stage 1, 1700 lb. Pressure Plate (Boxed)
- 4092 K.E.P. Stage 2, 2100 lb. Pressure Plate (Boxed)
- 4093 K.E.P. Stage 3, 2600 lb. Pressure Plate (Boxed)
- 4094 K.E.P. Stage 4, 3000 lb. Pressure Plate (Boxed)



4090

## 6 PUCK CLUTCH DISC

6 pads. 200mm with steel riveted hub.

- 16-9901 6 Puck Clutch Disc, 200mm, Each



16-9901

## REPLACEMENT CLUTCH BOLT SET

Replacement clutch bolt set features 10.9 zinc plated bolts. A must item to install to really insure against a broken bolt later on.

- B409020 **NEW!** HD Clutch Bolt Set



B409020



## CLUTCH INSTALLATION KIT

10.9 zinc plated bolts, wavy washers and a clutch pilot tool complete any VW clutch installation. [See page 458 for a complete listing of Clutch Pilot Tools.](#)

- 32-1204 Clutch Installation Kit
- 5302-K Clutch Pilot Tool Only (Skinpacked)
- 5302 Bulk Clutch Pilot Tool Only



32-1204



## **SUPER DUTY 200MM CLUTCH DISC**

Spring Steel Center Disc dampens disc action for a smoother engagement. The metal woven lining resists slip under heavy clamp loads to put horsepower to the ground.

**4085** Super Duty 200mm Clutch Disc



Side View

## **KUSH-LOK CLUTCH DISC**

The brass woven lining really takes the heat. The spring steel hub is sandwiched with dampening material to absorb vibration. Couple with a Kennedy pressure plate for the perfect street or strip set-up.

**4096** 200mm Kush-Lok Clutch Disc



4091

## **4-PUCK RACE DISC**

Features feramic discs, stainless rivets and long splines for quality and performance. Recommended for competition use only.

**4091** 4-Puck 200mm Disc



16-9900



Side View

## **KUSH LOCK CLUTCH DISC**

200mm with steel riveted hub and triple "sandwich" center for smooth Kush Lock action.

**16-9900** Kush Lock Clutch Disc, 200mm, Each



32-1208



32-1210



32-1205



98-1420-B

## **HEAVY DUTY THROW-OUT BEARINGS**

H.D. Throw-Out Bearings should be installed whenever replacing your Pressure Plate and/or Disc. Super Clips make sure it stays in place.

**32-1205** H.D. T/O Bearing, thru 70  
(Bulk P/N: 111 141 165A)

**32-1210** H.D. T/O Bearing, 71-on  
(Bulk P/N: 113 141 165B)

**32-1208** T/O Super Clips, thru 70, Pair  
(Bulk P/N: 111 141 177AS, Each)

**98-1420-B** Guide Sleeve, Clutch Release Bearing,  
Type 1 71-79, Ghia 71-74, Type 2 71-79, Type 3 71-73  
(Ref. P/N: 113 141 181B)





# CLUTCH & TRANSMISSION

## RACING CROSS SHAFTS

All new Racing Cross Shafts are quality manufactured for direct replacement of worn, broken, or poor quality cross shafts that just don't meet the demanding requirements of the clutch applications today. 16mm Bronze Bushing Kit is also available.

- 18-1041 **NEW!** Racing Cross Shaft, Type 1 & 3, 61-70, Type 2, thru 67
- 18-1042 **NEW!** Racing Cross Shaft, Type 1 & 3, 71-10/72
- 18-1043 **NEW!** Racing Cross Shaft, Type 2, 68-70
- 18-1044 **NEW!** Racing Cross Shaft, Type 2, 71-75
- 18-1045 **NEW!** 16mm Bronze Bushing Kit



## HEAVY DUTY CROSS SHAFTS

Our heavy duty throw-out bearing cross shafts are quality manufactured for direct replacement of worn, broken, or poor quality cross shafts that just don't meet the demanding requirements of the clutch applications today. 20mm Bronze Bushing Kit is also available.

- 18-1055 **NEW!** Heavy Duty Cross Shaft, Type 1, 73 & Later
- 18-1054 **NEW!** Heavy Duty Cross Shaft, Type 2, 76 & Later
- 18-1053 **NEW!** 20mm Bronze Bushing Kit



## CROSS SHAFTS

EMPI's Cross shafts are welded at critical points for performance and stock applications.

- 98-2011 H.D. Cross Shaft, Type 1 & 3, 61-70, Type 2, thru 67  
(Bulk P/N: 113 141 701CHD)
- 98-1417 H.D. Cross Shaft, Type 1 & 3, 71-10/72  
(Bulk P/N: 113 141 701E)
- 98-1411 H.D. Cross Shaft, Type 2, 68-70  
(Bulk P/N: 002 141 701)
- 98-1412 Cross Shaft, Type 2, 71-75  
(Bulk P/N: 002 141 701A)
- 98-1410 **NEW!** Cross Shaft, Type 1, 73 & Later  
(Bulk P/N: 113 141 701F)
- 98-1414 **NEW!** Cross Shaft, Type 2, 76 & Later  
(Bulk P/N: 091 141 701C)
- 98-1088 Cross Shaft Bushing Kit, 21mm, 61-72  
(Bulk P/N: 113 198 026) [See page 188 for picture.](#)





16-9903

## **HEAVY DUTY SIDE COVER FOR SWING AXLE**

Includes Bowden tube bracket.

16-9903

Heavy Duty Aluminum Side Cover for Swing Axle, 2 pc.



16-9905

## **HEAVY DUTY SIDE COVER FOR IRS**

16-9905

Heavy Duty Aluminum Side Cover for IRS, Each



17-2783

## **BILLET TYPE I SIDE COVER**

Precision machined Billet Side Cover, for swing axle, keeps the ring gear in place under load. Clearanced for mid-engine chassis. Use with P/N 17-2784 billet flange cover.

17-2783

Side Cover, Billet, Each

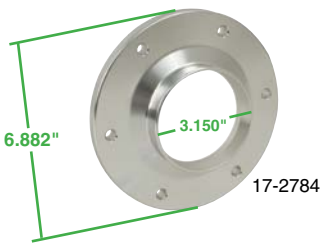

17-2784

## **BILLET AXLE FLANGE**

This billet flange cover is machined to be used on our 17-2783 billet side cover. May not fit other side covers.

17-2784

Axle Flange Cover, Billet, Each



16-9906

## **SIDE COVER RETAINERS**

Includes longer studs, washers, and nuts. For swing axle only.

16-9906

Side Cover Retainers, Kit



16-9904



16-9907

## **BOLT ON BOWDEN TUBE BRACKET**

Used for both Bowden tube and hydraulic clutch slave cylinders.

16-9904

Bolt on Bowden Bracket, Zinc, Each

16-9907

Bolt on Bowden Bracket, Late Bus, Chrome, Each



# CLUTCH & TRANSMISSION

## STEEL TYPE 2 SHIFT BALL

This hardened steel shift ball replaces the factory plastic unit which when subjected to any abuse will usually fail. Precision built to slip right in to your Type 2 IRS transaxle.

**B506110** Steel Shift Ball, Type 2 IRS



## HD BEARING THRUST PLATES

These strong steel main bearing thrust plates eliminate movement of main shaft bearing. Aids in maintaining the alignment of the gears on the main and pinion shafts to give the gears FULL contact thereby reducing the chances of failure. Allows use of 2 bolt nose cone on a 3 bolt (late model) style transmission (on the T-1 model) and 68 up on the Type 2.

**B505810** HD Bearing Thrust Plate, Type 1 & 3, 61-77  
**B505811** HD Bearing Thrust Plate, Type 2 IRS, 68-79



## BUGPACK IRS SUPER DIFFERENTIAL

These units provide the needed strength to withstand the abuse of high horsepower engines. They eliminate the stock housing flex problem in addition to providing for an extra pair of spider gears. Units also allow infinite ring gear lash adjustment and do not affect steering or steering brake operation.

**B507210** IRS Super Differential w/o Spider Gears



## BUGPACK SWING AXLE SUPER DIFFERENTIAL

After years of intensive research, we are now able to offer the FINEST transaxle Super Diffs ever made. Starting with a high quality, nonporous steel alloy casting and then we totally machine it using only the latest CNC state-of-the-art equipment. Added to this is a precision made steel alloy spider gear section and high tensile snap rings. Use the spider gears of your choice.

**B508110** Double Snap Ring Super Diff, Swing Axle, w/o Spider Gears



## RING GEAR BOLTS

Quality replacement 9mm Ring Gear Bolts available for both Swing Axle and I.R.S.

**98-5144-B** 9mm Special Bolt for Ring Gear, (Swing Axle, Short), Bulk, Each  
(Ref. P/N: 014 409 135A)  
**98-5145-B** 9mm Special Bolt for Ring Gear, (I.R.S., Long), Bulk, Each





## GEARSHIFT HOUSING AND GASKET

**98-3006-B** Gearshift Housing, Type 1 62-72 w/ Gasket (Mexico)  
(Ref. P/N: 113 301 205G)

**98-3008-B** Replacement Gasket Only, Shift Housing, Type 1 62-72,  
Ghia 62-72, Type 3 64-73, Each  
(Ref. P/N: 211 301 215)



## TRANSAXLE LOCK NUT KIT

Complete kit featuring nylon-insert locking nuts.

**9522** Trans-Axle Lock Nut Kit



## TRANSMISSION GASKET KIT

All gaskets and seals required to rebuild your transmission.

**98-2077** Transmission Gasket Kit  
(Bulk P/N: 111 398 005A)



## SPECIAL ENGINE STUDS

These 10mm X 100mm Studs solve the problem when adapting Type-2 transmissions to new engine cases. Extra length allows for use of engine mount plates for "all out" race cases.

**B653850** **NEW!** Special Engine Stud 10mm X 100mm, Pr.



## IRS PIVOT MOUNT BOLT & WASHER

Replace your worn or stripped Pivot Mount Bolts with new. 17mm Head. Fits all I.R.S. trans. Use tool number P/N 5788 or 5773 found on page 433.

**17-2826** Pivot Mount Bolt, Each

**17-2827** Pivot Mount Washer, Each



## FORGED CLUTCH CABLE ARMS TYPE I AND TYPE II

Forged heavy duty clutch cable arms.

**16-9908** Clutch Cable Arm, Type I 61-71 and all 002 Type II Transmission, Ea  
(Bulk P/N: 131 141 719HD)

**16-9909** Clutch Cable Arm, Type I 76-79 and all 091 Type II Transmission, Ea  
(Bulk P/N: 361 141 719HD)



## CROSS SHAFT BUSHING KIT

Re-bush your cross shaft housing for smooth action and trouble free operation.

**98-1088** Cross Shaft Bushing Kit, 21mm, 61-72  
(Bulk P/N: 113 198 026)



# CLUTCH & TRANSMISSION

## SOLID STEEL TRANS STRAP KIT

Heavy Duty Steel Saddle, Mount and Straps eliminate stock mounts and saddle for maximum support with no flex. A must for competition use (Zinc Plated).

9507 Steel Trans Strap Kit



## BUS IRS TRANS TO SEDAN KIT

Bolt in the beefier Bus IRS Trans into your IRS Bug with this adapter kit (Zinc Plated). For added strength and reliability, use EMPI Chromoly I.R.S. Race Axles. Most common is 15 5/8" - your particular application will dictate proper axle length needed. (Silver Plated). Use with P/N 17-2725 Shift Shaft Coupler, T1-T2, Page 383.

3195 Bus to Bug Trans Mount Kit

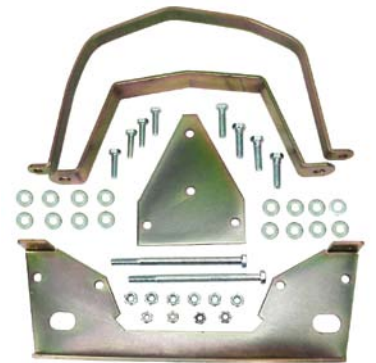

## EMPI CHROMOLY AXLES

- 16-2202 15 5/8", for Type 2 Trans/Type 1 & 2 Joints/Type 1 Suspension, Pair
- 16-2203 15 5/8", for Type 2 Trans/930 C.V. Joints/Type 1 Suspension, Pair
- 16-2206 19 1/4", for Type 2 Trans/Type 1 & 2 Joints/3 x 3 Arms, Pair
- 16-2207 19 1/4", for Type 2 Trans/930 C.V. Joints/3 x 3 Arms, Pair



## TRANS STRAP MOUNTING BOLT & WASHER

Replace your worn or stripped Trans Mount Bolts with new. For all swing axle Trans Mounts including stock cradle, securing the stock-style trans cradle or performance trans mounts to yoke.

- 17-2828 Trans Strap Mounting Bolt, Each
- 17-2829 Trans Strap Mounting Washer, Each



## TRANSMISSION CENTER SUPPORT

Secures transmission from the bottom of the front case bolts. Supports from frame horns to reduce flex, zinc plated. Urethane stops included.

17-2536 Bolt On Center Transmission Support



## BUS TRANSMISSION MOUNT

Weld in front mount brackets for late model bus transmission. Rear bolt mounts and hardware included.

- 17-2537 Bus Transmission Mount Kit
- 17-2538 Bus Transmission Center Mount Only





16-9551



## URETHANE TRANS MOUNTS

Made from Injection-Molded Red Urethane, these mounts greatly minimize flexing without the noise of solid steel mounts. Fits 61-72 Type 1.

9540  
9539

Urethane Mount Kit w/Hardware, 3-Piece Kit  
Urethane Front Mount Only with Bushings, 61-72 Type 1



9540

16-9551

Urethane Front Mount Only with Hardware, [Late Model 3-Bolt Nose Cone for Early Chassis](#)

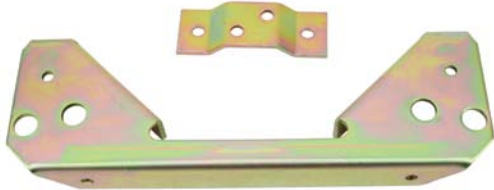

## HEAVY DUTY SOLID TRANS MOUNT KIT

Steel Saddle/Mount eliminates flex. A must for Buggies (Zinc Plated).

9530

Heavy Duty Trans Mount Kit



9532



9531

## TRANS SUPPORT KIT

Firmly encompasses trans and frame horns to reduce vibration and prevent flex and breakage. Rubber insulation reduces noise. Can be used with stock or urethane mounts (Zinc Plated).

9527

Trans Support Kit, Includes P/N: 9531 & 9532

9531  
9532

Front Support Kit Only  
Rear Support Kit Only



## DELUXE PADDED TRANS SUPPORT KIT

Maximum support with minimal noise. This kit features Heavy Channel-Style Rubber Insulation. Wraps around stock mount saddle. Can use stock or urethane mounts (Zinc Plated).

9550

Deluxe Trans Support Kit



9542



9543

## PADDED TRANS SUPPORT KIT

Maximum support while reducing noise, this kit features Channel-Style Rubber Insulation. Includes steel mount saddle that can accommodate stock or urethane mounts (Zinc Plated).

9541

Padded Strap Kit, Includes P/N: 9542/9543

9542  
9543

Front Kit Only  
Rear Kit Only



98-2074

9540

98-2074

(Bulk P/N: 113 301 263)

Urethane Mount Kit w/Hardware, 3-Piece Kit  
Stock Style Trans Mount, Rear, thru 72, Each



# CLUTCH & TRANSMISSION

## LATE MODEL TRANS MOUNT ADAPTOR

This late model trans mount adaptor takes the hassle out of all Type 1 '73 and later front mounts that require replacement or updating. The adaptor mount is paired with either our early style 2 bolt or later 3 bolt style urethane nose cone mounts. These mounts allow you to use either the early 2 bolt nose cone or later 3 bolt nose cone style transmissions in the late model chassis.

- B651950** **NEW!** Trans Mt. Adap. Kit, Late Chassis w/ 2 Bolt Nose Cone (Early Trans)
- B651960** **NEW!** Trans Mt. Adap. Kit, Late Chassis w/ 3 Bolt Nose Cone (Early Trans)



## SOLID TRANS MOUNTS

Steel Mounts replace stock rubber mounts to eliminate wheel hop and prevent transmission damage. Early 2 bolt and late model 3 bolt mount available. P/N: 9518/9528 kits include hardware (Zinc Plated).

- 9518** Early Model Steel Trans Mount Kit, Includes P/N: 9528 & 9529
- 9528** Early Model Steel Front Mount Only, Each
- 9529** Steel Rear Mounts, Pair
- 16-9910** Late Model Front Solid Mount, Kit

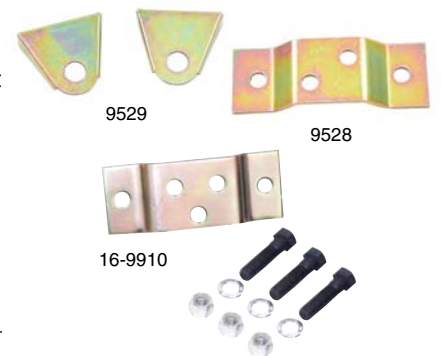

## STOCK TRANS MOUNTS

Replace cracked or broken mounts with new quality rubber mounts.

- 98-2070-B** Transmission Mount – Left Rear Type 1, 73-79, Each (Ref. P/N: 113 301 263C)
- 98-2071-B** Transmission Mount – Right Rear Type 1, 73-79, Each (Ref. P/N: 113 301 264)
- 98-2073-B** Transmission Mount – Front Type 2, 63-67 (Ref. P/N: 211 301 265A)
- 98-2074** Transmission Mount – Rear thru 72, Each (Bulk P/N: 113 301 263)
- 98-2075** Transmission Mount – Front Type 1, 62-65, Each (Bulk P/N: 311 301 265A)
- 98-2076** Transmission Mount – Front Type 1, 66-72, Each (Bulk P/N: 311 301 265B)
- 98-9972** Transmission Mount – Front Type 1, 73 & later, Each (Bulk P/N: 113 301 265E)



## TRANSAXLE ADAPTER

Allows the installation of a full-synchro 61 & later transaxle in 59 and earlier pans. Simple bolt-on installation with bolts and washers (Zinc Plated).

- 9520** Trans Axle Adapter Kit





## DUAL PORT URETHANE BOOTS

These are the solution to manifold boot problems. Made of corrosion resistant and super durable molded urethane. Quality Step-Style Boots available in Red or Black Urethane. Clamps and quality dual port intake gaskets are included in the two kits.

- 3403-B** Bulk Red Urethane D/P Boot, Each
- 3229** Dual Port Installation Kit utilizing Red Urethane Boots
- 3407-B** Bulk Black Urethane D/P Boot, Each
- 3228** Dual Port Installation Kit utilizing Black Urethane Boots

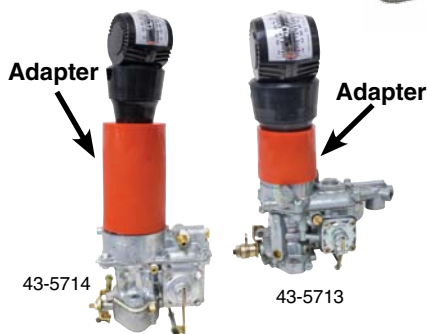

## CARBURETOR SYNCHRONIZER URETHANE ADAPTERS

Dialing in your Dual EPC34s, Weber ICTs and Solex/Brosol just got a bit easier! These urethane adapters are made specifically for these carburetors. With easy push-on fit, they are impervious to gas and oil. Even the Solex/Brosol Adapter fits without removing the air cleaner center stud. For use with P/N 43-5712 EMPI Universal Pro-Sync.

- 43-5713** Synchronizer Adapter 34EPC/34ICT Carburetors, Each
- 43-5714** Synchronizer Adapter Solex/Brosol Carburetors, Each



## URETHANE STEERING COUPLER

This Urethane Steering Coupler replaces the standard black rubber disk with a color coordinated, hi-tech polyurethane unit. Fits Type I.

16-5150



- 16-5150** Urethane Steering Coupler Kit (Red)
- 16-5149** Urethane Steering Coupler Kit (Black)



## DELUXE SWAY BAR MOUNTING KITS

Urethane Bushings with **Stainless Steel** T-Bolt type clamps. Fits both Ball Joint and Link Pin.

- 9592** Deluxe Mounting Kit, Stock Bar
- 9593** Deluxe Mounting Kit, 3/4" Bar



9592

9593



## URETHANE CV FLANGE SEALS

These special urethane seals fit right into the constant velocity joint flanges to prevent the axles from beating the transmission. Tough urethane will not tear or flatten like stock seals. Poly Plugs may require some fitting by sanding or filing. Sold in pairs.

- 17-2930** Poly Drive Flange Plug, Type 1, Pair
- 17-2931** Poly Drive Flange Plug, Type 2, Pair

17-2930

17-2931





# URETHANE COMPONENTS

## URETHANE TRANS MOUNTS

Made from Injection-Molded Red Urethane, these mounts greatly minimize flexing without the noise of solid steel mounts. Fits 61-72 Type 1.

- 9540 Urethane Mount Kit w/Hardware, 3-Piece Kit
- 9539 Urethane Front Mount Only with Bushings, 61-72 Type 1



Easily update to the stronger late model 3-bolt nose cone. A non-solid "bolt-in" conversion mount for late model 3-bolt nose cones into early style VW Type 1 chassis. Constructed of durable urethane and complete with all hardware. A "must" for all high performance street and off-road vehicles!

- 16-9551 Urethane Front Mount Only with Hardware, Late Model 3-Bolt Nose Cone for Early Chassis

## LATE MODEL TRANS MOUNT ADAPTOR

This late model trans mount adaptor takes the hassle out of all Type 1 '73 and later front mounts that require replacement or updating. The adaptor mount is paired with either our early style 2 bolt or later 3 bolt style urethane nose cone mounts. These mounts allow you to use either the early 2 bolt nose cone or later 3 bolt nose cone style transmissions in the late model chassis.

- B651950 **NEW!** Trans Mount Adapter Kit, Late Chassis w/ 2 Bolt Nose Cone (Early Trans)
- B651960 **NEW!** Trans Mount Adapter Kit, Late Chassis w/ 3 Bolt Nose Cone (Early Trans)

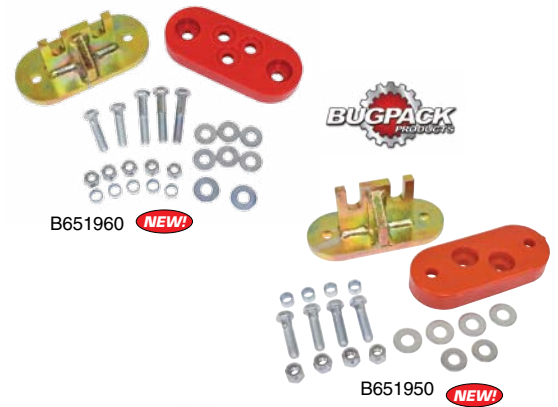

## SHIFTER BOX BUSHING

We now offer a trick bolt-on urethane shift rod bushing. Now you no longer have to worry about the OEM bushing falling out or breaking. This product also eliminates all the slop since it is firmly mounted and fits snugly on the shift rod.

- 16-5101 Urethane Buggy Shifter Box Bushing, (Black)



## URETHANE SHIFT COUPLER

This heavy duty shifter coupler replaces all round stock couplers. Designed for trouble free installation. Can be used with our shift rod kit.

- 16-5102 Urethane Shift Coupler, Early Style



## URETHANE SHIFT COUPLER SETS

The strength and durability of Urethane will out-last and out-perform standard rubber products in every application. This setup ends the trouble of a sloppy shifter coupling. Utilizing urethane bushing pads instead of rubber, the "slop" and vague feeling disappear. Sold as a complete set.

- 16-5103 Urethane Shift Coupler, Late Style, Kit (Ref. P/N: 311 798 211) Type 1 65-79, Ghia 65-74, Type 3 All, Kit



Heavy Duty Steel Cage with heavy duty bolt and Urethane Inserts make this H.D. Coupler the one to use for any performance application.

- 16-5105 H.D. Shift Coupler w/Urethane Inserts & Hardware., Type 1 65-79, Ghia 65-74, Type 3 All, Kit
- 16-5104 **NEW!** Urethane inserts only for Shift Coupler, Pair



## CARB ISOLATORS

These innovative Isolator Mounts fit between the intake manifold & carburetor to dampen fuel vibrations in EMPI and Weber float bowls. By absorbing the shock you will reduce fuel foaming, cut down on erratic needle & seat motion, stabilize the fuel curve. Made from specially formulated polyurethane.

**B156212** **NEW!** Carb Soft Mounts, Fits 40 IDF Webers & EMPI 40 HPMX, Pair, Black

**B156214** **NEW!** Carb Soft Mounts, Fits 48IDA-48IDF Webers & EMPI EPC 48's, Pair, Black



## SWAY BAR BUSHING KITS

**B650031** **NEW!** Sway Bar Bushing Kit, Frt. 3/4" Super Beetle 71-73, Red

**B650032** **NEW!** Sway Bar Bushing Kit, Frt. 3/4" Super Beetle 74-79, Red

**B650034** **NEW!** Repl. Bushing Kit, Front 12mm Bar Link Pin / Ball Joint, Red (Original Bugpack P/N was 6500-010)

**B650035** **NEW!** Repl. Bushing Kit, Front 3/4" Bar Link Pin / Ball Joint, Red (Original Bugpack P/N was 6500-011)



## URETHANE FRONT BEAM BUSHING KITS

We offer the most extensive line of front end bushings in the business. These bushings take the "movement" out of a new or old front end while providing the superior suspension qualities that only urethane can provide. Since urethane is impervious to the elements and wear like "iron"- you'll enjoy many years of performance. In/Out bushings are long one piece units designed to replace BOTH inner and outer with one bushing at the same time giving greater surface to the trailing arm (including custom aluminum and steel beams) while the others replace the outer only.

**B652300** **NEW!** Bushing Kit, Outer, Micarta Link Pin, Red

**B652320** **NEW!** Bushing Kit, In/Out, Micarta Link Pin, Red

**B652400** **NEW!** Bushing Kit, Outer, Needle Bearing Link Pin, Red

**B652411** **NEW!** Bushing Kit, Outer, Ball Joint, Red

**B652420** **NEW!** Bushing Kit, In/Out, Needle Bearing Link Pin, Red

**B652421** **NEW!** Bushing Kit, In/Out, Ball Joint, Red

**B658410** **NEW!** Bushing Kit, In/Out, Fits 45mm Alum. Tube, Red

**B658411** **NEW!** Bushing Kit, In/Out, Fits 46mm Steel Tube, Red





# URETHANE COMPONENTS

## URETHANE FRONT BEAM SEALS

High quality urethane parts to replace those stock parts. Not only do they outperform stock parts but they look sharp. Inexpensive suspension upgrade.

- B652310** Urethane Front End Seals, Linkpin, (4), Red
- B652410** Urethane Front End Seals, Ball Joint, (4), Red

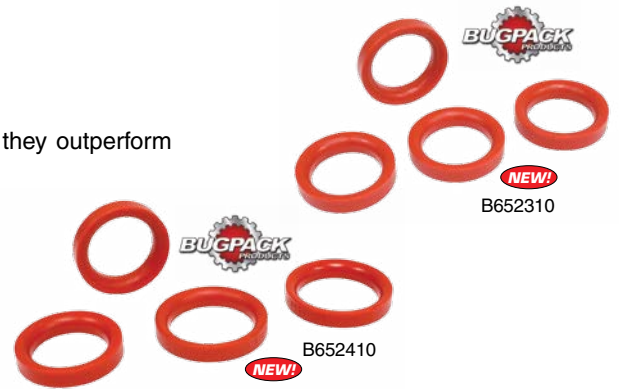

## CONTROL ARM BUSHINGS

Now the Superbeetle owner can replace his inferior front control arm rubber bushings with these hi-performance urethane pieces. You'll get improved handling due to reduction in the flex and the alignment will last longer. Ideal replacement for worn stock rubber bushings, these urethane units will out last stock rubber bushings. One kit does the whole car.

- B652429** Frt. Control Arm Bushing Kit, Super Beetle, 71-73, Red
- B652430** Frt. Control Arm Bushing Kit, Super Beetle, 74-79, Red
- B652431** Frt Cntr Arm & S Bar Bush Kit, Super Beetle, 71-73, Red
- B652432** Frt Cntr Arm & S Bar Bush Kit, Super Beetle, 74-79, Red



## BUS BEAM BUSHINGS

These 3 different bushing kits are made to fit 1955-63, 1964-67 and 1968-1979 as stock replacements or can be used on narrowed beams as well. The specially formulated polyurethane bushings offer years of trouble free motoring when used with supplied synthetic waterproof based grease. Now the Type 2 owners can have the improved performance that only polyurethane can provide.

- B652710** Bus Beam Bushing Kit, 55-63, (4), Red
- B652711** Bus Beam Bushing Kit, 64-67, (4), Red
- B652712** Bus Beam Bushing Kit, 68-79, (4), Red





## URETHANE A-ARM GROMMET KIT

Another problem area solved with this slick suspension item. These new urethane a-arm bushings prevent vertical motion at the pivot point which is greatly magnified at the end of the arm, altering any carefully planned alignment. Kit comes complete with four bushings and two steel sleeves to do the job right. Easy slip-in installation.

**B655700** **NEW!** Rear IRS A-Arm Bushings w/ Sleeves, Red



## BUMP STOPS

These stops are made of tough urethane, to far outlast any rubber or nylon types currently used. Stops are designed to distribute the load equally. Sold in pairs.

**B658500** **NEW!** Bump Stop, 7/8" x 1 7/8" x 1 3/8" w/ Center Stud, Pr., Red  
**B658510** **NEW!** Bump Stop, Curved Bottom w/ Center Stud, Pr., Red  
**B658511** **NEW!** Bump Stop, 5/8" x 2" x 2" Square w/ Center Stud, Pr., Red

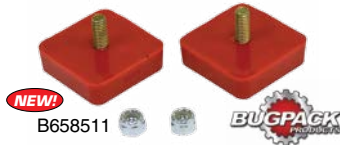

## URETHANE SNUBBERS

Under most harsh conditions these super tough urethane snubbers will finish the race with you. Resists splitting commonly found with the stock rubber type. Set of two. Fits Type 1 to '65 and Type 2 to '67.

**B658600** **NEW!** Urethane Front Snubbers, Pair, Red



## BUMP STOPS

Replace those worn out stock rubber bump stops with urethane replacements for all Type 1, 2, and 3 applications.

**B658913** **NEW!** Rear Bump Stop, Type 1 & Type 3, Pair, Red  
**B658923** **NEW!** Rear Bump Stop, Type 2, Pair, Red



## URETHANE TIE ROD BOOTS

Made from urethane, these boots are made to withstand the abuse of off-road racing. Superior design keeps dust and dirt from wearing out tie rod end prematurely and they look good.

**B557521** **NEW!** Urethane Tie Rod Boots, Stock VW, (4), Red



# URETHANE COMPONENTS

## URETHANE REAR GROMMETS

Rear spring plate grommets designed not to crunch and “bottom out” as soft stock rubber grommets do. The flanged series of grommets are designed for custom made torsion housings.

**Note: B658716 Grommet is designed for custom torsion housings only and is used between the spring plate and the torsion housing (inboard side) while the B658713, 14, 15 grommets are used on the outboard side of the spring plate when utilizing custom torsion/spring plate covers.**

- B658710** NEW! Knobby Type Grommets, 1-3/4" I.D., Pr., Red
- B658711** NEW! Knobby Type Grommets, 1-7/8" I.D., Pr., Red
- B658712** NEW! Knobby Type Grommets, 2" I.D., Pr., Red
- B658713** NEW! Flanged Grommets, 2-1/4" O.D x 1-7/8" I.D., Pr., Red
- B658714** NEW! Flanged Grommets, 2-1/4" O.D x 1-3/4" I.D., Pr., Red
- B658715** NEW! Flanged Grommets, 2" O.D x 1-3/4" I.D., Pr., Red
- B658716** NEW! Flange Only Grommet, 1-7/8" x .187", Pr., Red
- B658810** NEW! Round Type Grommets, 1-3/4" I.D.,  
Early Swing Axle w/ **EMPI H.D. Spring Plates**, Pr., Red
- B658812** NEW! Round Grommets, 1-7/8" I.D., **Large O.D.**,  
**Early Swing Axle**, Pr., Red
- B658813** NEW! Round Type Grommets, 1-7/8" I.D., **Small O.D.**, IRS., Pr., Red



### URETHANE GROMMETS FOR REAR TORSION SUSPENSION

#### SWING AXLE FOR STOCK SPRING PLATE

YEAR	VEHICLE	INSIDE	DESCRIPTION	OUTSIDE	DESCRIPTION
1950-1959	Type I	<b>B658812</b>	1 7/8" Round	<b>B658812</b>	1 7/8" Round
1960-1968	Type I	B658711	1 7/8" Knobby	B658710	1 3/4" Knobby
1965-1968	Type III	B658711	1 7/8" Knobby	B658711	1 7/8" Knobby

#### IRS AXLE FOR STOCK SPRING PLATE

YEAR	VEHICLE	INSIDE	DESCRIPTION	OUTSIDE	DESCRIPTION
1969-1979	Type I+III	B658711	1 7/8" Knobby	S/B B658813	1 7/8" Round



## SOFT SPRING PLATE GROMMETS

Re-designed spring plate grommets constructed of a softer polyurethane compound offer both a superb fit and ride. Available in black polyurethane for that factory look for both swing axle and IRS applications. Work great with aftermarket spring plate covers.

- B658720** Knobby Type Grommets, 1-3/4" I.D., Pr., Black
- B658721** Knobby Type Grommets, 1-7/8" I.D., Pr., Black
- B658820** Round Type Grommets, 1-3/4" I.D. Early Swing Axle, w/ **EMPI H.D. Spring Plates**, Pr., Black
- B658822** Round Type Grommets, 1-7/8" I.D., Large O.D., **Early Swing Axle**, Pr., Black
- B658823** Round Type Grommets, 1-7/8" I.D., Small O.D. IRS, Pr., Black



### URETHANE GROMMETS FOR REAR TORSION SUSPENSION (SOFT BLACK)

#### SWING AXLE FOR STOCK SPRING PLATE

YEAR	VEHICLE	INSIDE	DESCRIPTION	OUTSIDE	DESCRIPTION
1950-1959	Type I	B658822	1 7/8" Round	B658822	1 7/8" Round
1960-1968	Type I	B658721	1 7/8" Knobby	B658720	1 3/4" Knobby
1965-1968	Type III	B658721	1 7/8" Knobby	B658721	1 7/8" Knobby

#### IRS AXLE FOR STOCK SPRING PLATE





YEAR	VEHICLE	INSIDE	DESCRIPTION	OUTSIDE	DESCRIPTION
1969-1979	Type I-III	B658721	1 7/8" Knobby	B658823	1 7/8" Round



# URETHANE COMPONENTS

## URETHANE TOTAL KITS

Total Kits offer the opportunity to obtain all the parts necessary to complete the conversion of your suspension system to urethane. Total Kits save time, money and hassles. The kits are boxed.

- B222001**  Total Kit, Volkswagen, Type 1, 59-65, Red
- B222002**  Total Kit, Volkswagen, Type 1, 66-72, Red
- B222003**  Total Kit, Volkswagen, Type 1, 73-77, Red
- B222004**  Total Kit, Volkswagen, Super Beetle, 71-79, Red



 **NEW!**  
B222001



 **NEW!**  
B222002



 **NEW!**  
B222003



 **NEW!**  
B222004

## LUBE 1/2 OZ.

- B650033**  Lube 1/2 oz. (Pack of 3), Skinpacked







## FRONT END ADJUSTERS

Requires one on each tube. Cutting and welding required. Allows for 2" of adjustment either up, or down.

- 22-2801 Adjuster, Ball Joint, 66 & Later, Each
- 22-2802 Adjuster, Link Pin, 65 & Prior, Each



## SELECT A DROP

The original Front End Adjuster. Requires cutting & welding.

- 9501 Select A Drop Kit

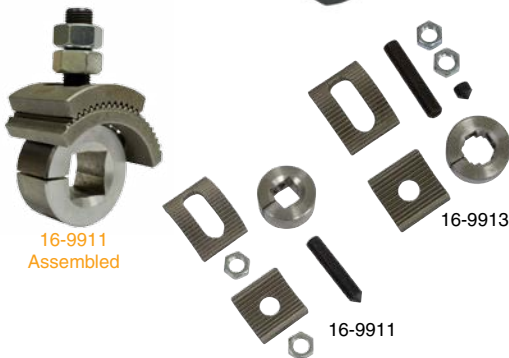

## WELD ON ADJUSTERS FOR STEEL BEAMS

These adjusters can be welded in place, to raise or lower the ride height. Removal of the beam and welding are involved. Available for link pin and ball joint beams.

- 16-9911 Weld on Beam Adjuster, Link Pin, Each
- 16-9913 Weld on Beam Adjuster, Ball Joint, Each



## GRUB SCREW KIT

Grub Screw Kit for Torsion Leaves. Includes (4) Grub Screws and (4) Nuts for Grub Screw. Type 1 50-77, Ghia 56-74, Type 2 50-79, Type 3 64-73, Kit

- 98-4165 **NEW!** Grub Screw Kit for Torsion Leaves  
Type 1 50-77, Ghia 56-74, Type 2 50-79, Type 3 64-73, Kit
- 98-4166-B Grub Screw for Torsion Leaves, Type 1 50-77, Ghia 56-74,  
Type 2 50-79, Type 3 64-73, Each  
(Ref. P/N: 111 411 151)
- 98-4165-B Nut for Grub Screw, Type 1 50-77, Ghia 56-74,  
Type 2 50-79, Type 3 64-73, Each  
(Ref. P/N: 111 411 155)



## CASTER SHIMS

Aluminum Caster Shims correct and improve front end geometry on your lowered VW. The longer Caster Shim Bolts provide proper thread grip at pan head.

- 22-2815 Caster Shim, Pair
- 22-2816 Caster Shim Bolts, Pair





# SUSPENSION & STEERING

## KING PIN/LINK PIN REBUILDING KITS

New Link and King Pin sets. Each kit is enough for both sides. Fits Type 1, thru 65.

**98-2065** King Pin Rebuilding Kit  
(Bulk P/N: 111 498 021)

**98-2066** Link Pin Rebuilding Kit  
(Bulk P/N: 111 498 051A)



## SWING LEVER REBUILD KIT (TYPE 2)

The vertical pin and bushing that transfers the fore-aft motion of the steering to the side-side motion needed to steer the tires. Kit includes bushings, pin, etc. A reamer is not required to install this kit.

**98-4174-B** **NEW!** Swing Lever Rebuild Kit, Type 2 68-79  
(Ref. P/N: 211 498 171A)



## TIE ROD RELOCATION KIT

Eliminate added bump steer and unnecessary tie rod end wear on all lowered ball joint & Link pin front ends. Relocates tie rod end to underside of steering knuckle for improved angles. Requires drilling and the use of late model tie rod ends. Front-end alignment will be necessary for a complete installation.

**B661311** **NEW!** Tie Rod Relocation Bushing Kit, Pr.



## FRONT END CLAMPS

Mount a VW axle beam to a tube chassis with our Front End Clamps. Made from heavy duty stamped steel. Use the chrome plated clamps for that custom look or the raw version for fabrication. Also can be used to mount Baja Tube Bumpers.

**3162** Chrome Axle Beam Clamp Kit, 4 pcs.  
**3162-7** Bulk Chrome Axle Beam Clamp, Each

**3161** Raw Axle Beam Clamp Kit, 8 pcs. (Incl. Hardware)  
**3161-7** Bulk Raw Axle Beam Clamp, Each





22-2810

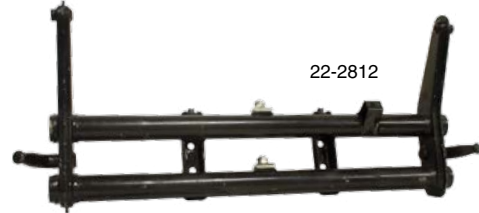

22-2812

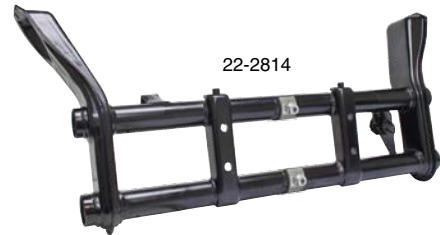

22-2814

**FOR LOWERED SPINDLES**



Adjuster welded in a more "neutral" position for Drop Spindles



22-2819

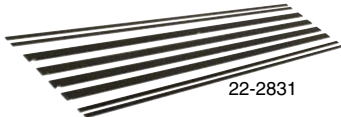

22-2831



22-2853



22-2854



9692

## AXLE BEAMS

Brand new Axle Beams with Adjusters already installed. Available for both Early & Late Type 1. Beams with adjusters are not to be used if stock ride height is desired.

**22-2812** Lowered Link Pin Beam w/Ratchet Style Adjusters

**22-2810** Lowered Ball Joint Beam w/Ratchet Style Adjusters.

For use with stock length shocks only

## REPLACEMENT TORSION LEAVES

Install in your new stock-width Lowered Beam or just to freshen your ride in your stock beam. (Note: Two sets of leaves required per beam).

**98-4540-B** Replacement Torsion Leaves, Standard Width, Link Pin (Ref. P/N: 111 411 027)

**98-4541-B** Replacement Torsion Leaves, Standard Width, Ball Joint (Ref. P/N: 131 411 107A)

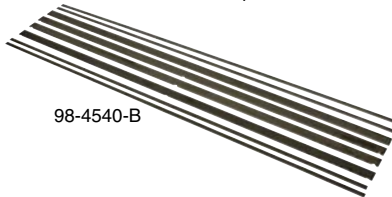

98-4540-B

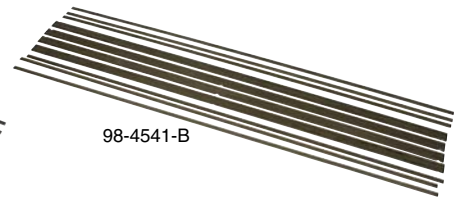

98-4541-B

## NARROWED BEAMS WITH ADJUSTERS

Now available from EMPI. 2" Narrowed, Adjustable Front Beams. This is the solution to front tire clearance issues when using disc brake conversions, negative wheel offsets, or wider wheels and tires. Link Pin and Ball Joint versions are available along with narrowed leaves, tie rods, and sway bars. (Note: Two sets of leaves required per beam). Also available for drop spindles.

**22-2818** 2" Narrowed Beam with Ratchet Style Adjusters, Link Pin

**22-2814** 2" Narrowed Beam with Ratchet Style Adjusters, Ball Joint for Dropped Spindles,

For use with stock length shocks only

**22-2819** 2" Narrowed Beam with Ratchet Style Adjusters, Ball Joint, For use with stock length shocks only



Ratchet-Style Adjusters



Bearings Installed!



22-2818

**22-2831** Narrowed Leaves for Link Pin, 1 Set (Two sets required)

**22-2832** Narrowed Tie Rods for Link Pin, 23 3/4" & 8 1/4", 1 Pr.

**22-2833** Narrowed Sway Bar for Link Pin, 3/4" O.D.

**22-2852** Narrowed Leaves for Ball Joint, 1 Set (Two sets required)

**22-2853** Narrowed Tie Rods for Ball Joint, 22 7/8" & 8", 1 Pr.

**22-2854** Narrowed Sway Bar for Ball Joint, 3/4" O.D.

**9692** S/S Clamps Only, Link Pin/Ball Joint, Type 1, Set of 4



# SUSPENSION & STEERING

## URETHANE BUSHINGS

- 16-5136 Urethane Axle Beam Bushing Kit, **Outer**, for King & Link w/Micarta Bushings, 4 pcs., All the Same
- 16-5137 Urethane Axle Beam Bushing Kit, **Outer**, for King & Link Pin w/Bearings, 4 pcs., All the Same
- 16-5140 Urethane Axle Beam Bushing Kit, **Inner & Outer**, for King & Link Pin w/Needle Bearings, 4 pcs., All the Same
- 16-5139 Urethane Axle Beam Bushing Kit, **Inner & Outer**, for King & Link Pin w/Micarta Bushings, 4 pcs., All the Same
- 16-5141 Urethane Axle Beam Bushing Kit, **Outer**, for Ball Joints, 4 pcs. Short (Replacement) Style, for Outer Only, 2 Small, 2 Large
- 16-5142 Urethane Axle Beam Bushing Kit, **Inner & Outer**, for Ball Joint, 4 pcs., 2 Small, 2 Large
- 16-5143 Urethane Axle Beam Bushing Kit, 6" Long, No Collar, for Aluminum Beams w/45mm Tubes, 4 pcs., All the Same
- 16-5144 Urethane Axle Beams Bushing Kit, 7.35" Long w/ .006" Collar & Fluted ID. for Aluminum or Steel Beams 2.000" O.D. Tube/.120 Wall, 4 pcs., All the Same
- 16-5146 Urethane Axle Beam Bushing Kit for any of our Off-Road Axle Beams, 4 pcs., All the Same
- 16-5138 Urethane Axle Beam Tube Seals, Type 1 w/King & Link Pin, 4 pcs., All the Same
- 16-5145 Urethane Axle Beam Tube Seals, Type 1 w/Ball Joint, 4 pcs., 2 Small, 2 Large

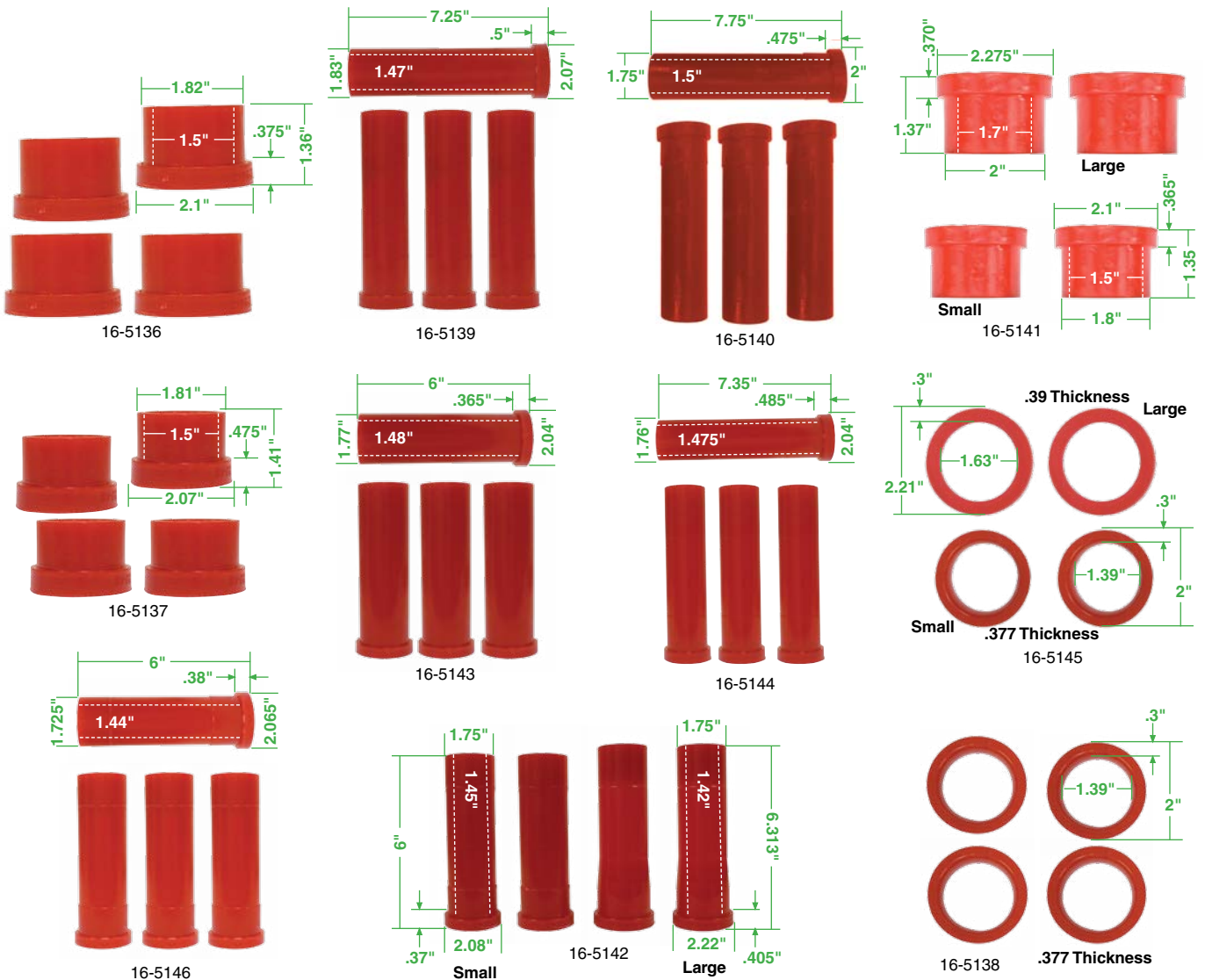

## URETHANE BUSHINGS, COUPLERS & STOPS

The strength and durability of Urethane will out-last and out-perform standard rubber products in every application. From Shift Couplers to Bump Stops, install Urethane and never look back! All urethane is red in color except where noted.



16-5101  
16-5102  
16-5103

Urethane Buggy Shifter Box Bushing, (Black)  
Urethane Shift Coupler, Early Style  
Urethane Shift Coupler, Late Style, Kit  
(Ref. P/N: 311 798 211)



**Heavy Duty Steel Cage with heavy duty bolt and Urethane Inserts make this H.D. Coupler the one to use for any performance application.**

16-5105

H.D. Shift Coupler w/Urethane Inserts & Hardware.,  
Type 1 65-79, Ghia 65-74, Type 3 All, Kit



16-5104

**NEW!**

Urethane inserts only for Shift Coupler, Pair



16-5107  
16-5108

Urethane Control Arm Bushing Kit - S/B 71-73, w/ grease (15-Piece Kit)  
Urethane Control Arm Bushing Kit - S/B 74-79, w/ grease (15-Piece Kit)



16-5109

Urethane Snubber - Link Pin, Pair



16-5122

Urethane I.R.S. A-Arm Pivot Bushings, Pair



# SUSPENSION & STEERING

## URETHANE BUSHINGS, COUPLERS & STOPS (CONT.)

- 16-5123 Urethane Round Stacked Bump Stop, Pair
- 16-5125 Urethane Rear Snubber - All Bugs, Pair
- 16-5126 Urethane Rectangle Bump Stop, Pair
- 16-9547 Urethane Shaped Bump Stop 2" Long for 1 1/2" Tube, Pair
- 16-9548 Urethane Shaped Bump Stop 4" Long for 1 1/2" Tube, Pair
  
- 16-5130 Urethane Knobby Bushings - 1 3/4" I.D., Pair
- 16-5131 Urethane Knobby Bushings - 1 7/8" I.D., Pair
- 16-5132 Urethane Knobby Bushings - 2" I.D., Pair
- 16-5133 Urethane Smooth Bushings - 1 3/4" I.D., Pair
- 16-5134 Urethane Smooth Bushings - 1 7/8" I.D., Pair
  
- 16-5150 Urethane Steering Coupler Kit (Red)
- 16-5149 Urethane Steering Coupler Kit (Black)



16-5123



16-5125



16-5126



16-9547

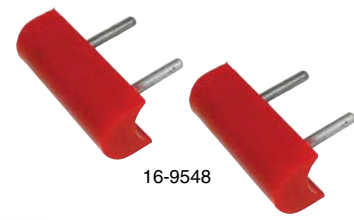

16-9548



16-5130



16-5131

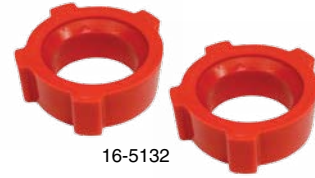

16-5132



16-5133



16-5134



16-5150



16-5149

### Urethane Bushing Application Guide

For use with Stock Spring Plates:

<b>Type 1, Swing Axle, 1950-1959:</b>	1 7/8" Round Inner	–	1 7/8" Round Outer
<b>Type 1, Swing Axle, 1960-1968:</b>	1 7/8" Knobby Inner	–	1 3/4" Knobby Outer
<b>Type 1, I.R.S., 1969-1979:</b>	1 7/8" Knobby Inner	–	1 7/8" Round Outer
<b>Type 1, All with Semi-Automatic Trans:</b>	1 7/8" Knobby Inner	–	1 7/8" Round Outer
<b>Type 3, Swing Axle, 1965-1968:</b>	1 7/8" Knobby Inner	–	1 7/8" Knobby Outer
<b>Type 3, I.R.S., 1969-1979:</b>	1 7/8" Knobby Inner	–	1 7/8" Round Outer

For Use with Aftermarket Spring Plates *Listed on this Page:*

*The tubes welded on the spring plates are different than stock. The O.D. of the inner tube is also different than the O.D. of the outer tube.*

<b>Non-Adjustable Spring Plates:</b>	1 3/4" O.D. on Inner Tube	–	1 7/8" O.D. on Outer Tube
<b>Adjustable Spring Plates:</b>	2" O.D. on Inner Tube	–	1 7/8" O.D. on Outer Tube



## URETHANE TIE ROD BOOTS

Made from urethane, these boots are made to withstand the abuse of off-road racing. Superior design keeps rust and dirt from wearing out tie rod end prematurely and they look good.

**B557521** **NEW!** Urethane Tie Rod Boots, Stock VW, Red, 4 Pc.



## TIE ROD RELOCATION KIT

Eliminate added bump steer and unnecessary tie rod end wear on all lowered ball joint & Link pin front ends. Relocates tie rod end to underside of steering knuckle for improved angles. Requires drilling and the use of late model tie rod ends. Front-end alignment will be necessary for a complete installation.

**B661311** **NEW!** Tie Rod Relocation Bushing Kit, Pr.



## EMPI TIE ROD ENDS TYPE 1, 2, 3

**113 415 821** **98-4518-B** Left Inner Tie Rod End, Type 1, thru 5/68 (Angled)  
**113 415 813** **98-4515-B** Right Inner Tie Rod End, Type 1, thru 65

**113 415 813D** **98-4516-B** Right Inner Tie Rod End, Type 1, 66-5/68

**131 415 821A** **98-4519-B** Left Inner Tie Rod End, Type 1, 5/68-77  
 Exc. Super Beetle (Angled)

**131 415 813E** **98-4517-B** Right Inner Tie Rod End, Type 1, 5/68-77  
 Exc. Super Beetle

**131 415 811** **98-4511-B** Left Outer Tie Rod End, Type 1/3, thru 5/68,  
 Type 2 55-67

**131 415 812** **98-4512-B** Right Outer Tie Rod End, Type 1/3, thru 5/68,  
 Type 2 55-67

**311 415 811C** **98-4513-B** Left Outer Tie Rod End,  
 Type 1/3, 5/68-77 Exc. Super Beetle,  
 Type 2 68-79, Inner Tie Rod End, Left & Right,  
 Super Beetle 71-74

**311 415 812C** **98-4514-B** Right Outer Tie Rod End,  
 Type 1/3, 5/68-77 Exc. Super Beetle,  
 Type 2 68-79, Outer Tie Rod End, Left & Right,  
 Super Beetle 71-79



# SUSPENSION & STEERING

## **BILLET ALUM. STEERING BOX COVER & MOUNT**

Are these cool or what? Outside of having your steering box housing chromed (no easy feat) there are few ways to make that hunk of metal look better, until now. (For use only on Type 1 & 3 with P/N: 113 415 061C steering box).

- 16-7508 Billet Aluminum Steering Box Cover
- 16-7509 Billet Aluminum Steering Box Mount



16-7509



16-7508



## **STEERING BOX (NEW OUTRIGHT, NO CORE)**

- 113 415 061C 98-4155-B TRW / Varga Steering Box, All Type 1 & 3 (Exc. Super Beetle)
- 113 415 061CBR 98-4156-B Steering Box, All Type 1 & 3 (Exc. Super Beetle)



113 415 061C

## **STEERING SHAFT WITH JOINTS**

- 113 415 951B 98-4151-B Steering Shaft w/Joints, Super Beetle, 71-74



113 415 951B

## **CHROME TIE RODS**

High luster chrome tie rods add the finishing touch to street cars, sand rails or buggies. Provided in see thru poly bags.

- 22-2825 Left Chrome Tie Rod, Type 1, thru 65
- 22-2829 Right Chrome Tie Rod, Early w/o Damper Provision
- 22-2827 Right Chrome Tie Rod, Type 1, thru 65
- 22-2826 Left Chrome Tie Rod, Type 1, 5/68-77 Exc. Super Beetle
- 22-2830 Right Chrome Tie Rod, Late w/o Damper Provision
- 22-2828 Right Chrome Tie Rod, Type 1, 5/68-77 Exc. Super Beetle



## **EMPI TYPE 1 & 2 TIE RODS & DRAG LINKS**

- 113 415 801 98-4591-B Left Tie Rod, Type 1, thru 65 (Adjustable)
- 113 415 802B 98-4590-B Right Tie Rod, Type 1, thru 65 (Adjustable)
- 131 415 801F 98-4587-B Left Tie Rod, Type 1, 5/68-77 Exc. Super Beetle
- 131 415 802E 98-4586-B Right Tie Rod, Type 1, 5/68-77 Exc. Super Beetle
- 133 415 801 98-4584-B Left & Right Tie Rod, Super Beetle, 71-74, Each
- 211 415 801F 98-4583-B Left Tie Rod, Type 2, 68-79



113 415 801

113 415 802B

131 415 801F

131 415 802E

133 415 801

211 415 801F



## EMPI BALL JOINTS

- 131 405 361F      98-4522-B    Upper Ball Joint, Type 1, 66-on, Each
- 131 405 371G      98-4523-B    Lower Ball Joint, Type 1, 66-on, Each
- 113 407 361E      98-4525-B    Ball Joint, Super Beetle, 71-5/73, Each
- 211 405 371A **NEW!** 98-4524-B    Ball Joint, Type 2, 68-79, Each



## EMPI LOWERED / RAISED BALL JOINTS

Specially modified ball joints allows more suspension travel for lowered or raised cars. Fits all Type 1, 66-77.

- 22-2820      Upper Clearanced Ball Joint, Each
- 22-2821      Lower Clearanced Ball Joint, Each



## EMPI CAMBER ADJUSTERS

When you lower the front of your beetle, the stock camber adjusters on the ball joint front end are unable to compensate enough to maintain proper camber. With EMPI's precision made Camber Adjusters the wheels can be properly aligned.

- 22-2817      Camber Adjusters, for Ball Joint, Pair



## EMPI STEERING DAMPERS

Feeling a little shakeeeee lately? Replace that worn out and leaking Steering Damper with a new one.

- 113 425 021      98-4251-B    Steering Damper, All Type 1 & Ghia Exc. Super Beetle
- 211 425 021A **NEW!** 98-4253-B    Steering Damper, Type 2, 55-79





# SUSPENSION & STEERING

## SWAY BARS

Improve handling and control body sway while preventing wheel hop under hard cornering. The Type 1 and 3 sway bars are made from heavy 3/4" steel, the Type 2 is made from beefy 7/8". All EMPI High Performance Sway Bars feature zinc plated steel components and hardware along with red urethane bushings.

### TYPE 1 SWAY BARS, 3/4"

- 9594 Front Ball Joint, 66 & Later, **Lowered**
- 9595 Front Link Pin, thru 65, **Lowered**
- 9596 Front Link Pin, thru 65
- 9600 Front Ball Joint, 66 & Later

Note: Above 4 numbers reuse original clamps. Stainless steel clamps can be purchased separately.

- 9599 Front Super Beetle, thru 73
- 9601 Front Super Beetle, 74 & Later

Note: Above 2 numbers use original mounting brackets.

- 9598 Rear Swing Axle, thru 68 (Exc. Auto-Stick)
- 9597 Rear I.R.S., 69 & Later
- 9615 Camber Compensator, Swing Axle, thru 68

### TYPE 2 SWAY BARS, 7/8"

- 9606 Front, 55-67
- 9611 Front, 68-79

Note: Above 2 numbers reuse original clamps.

- 9610 Rear, I.R.S., 68-79 

### TYPE 3 SWAY BARS, 3/4"

- 9598 Rear, Swing Axle, thru 68 (Exc. Auto-Stick)
- 9597 Rear, I.R.S., 69 & Later

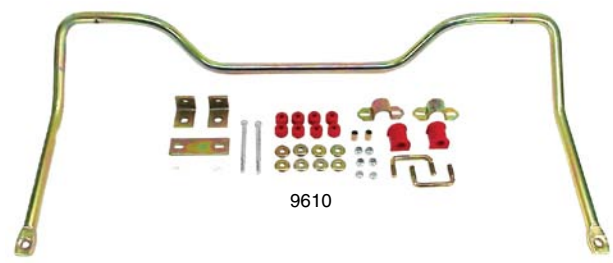
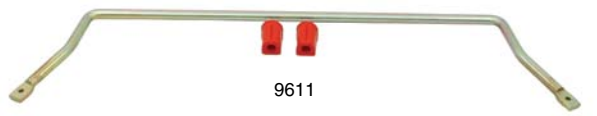
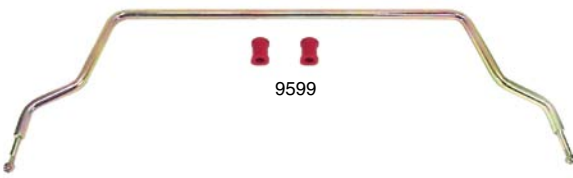
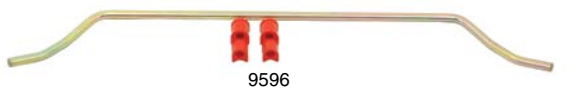



## REAR TRUSS BAR

Triangulates the shock towers and the frame horns, helping to prevent movement of the engine and trans upon acceleration preventing wheel hop. Adjustable rod ends allow for variations and/or preload. Features 3/4" Steel Tubing, Powder-Coated Black for good looks and durability. Fits 1961 & Later Beetle, S/B and Ghia – Swing Axle and I.R.S. Does not fit Thing and will not fit with SR-17 and other tall starters. Some applications may require slight trimming/modification to the body panels for installation.

17-2975

Rear Truss Bar, Type 1, Kit.



9593

## DELUXE SWAY BAR MOUNTING KITS

Urethane Bushings with **Stainless Steel** T-Bolt type clamps. Fits both Ball Joint and Link Pin.

9592

Deluxe Mounting Kit, Stock Bar

9593

Deluxe Mounting Kit, 3/4" Bar



9692

Clamps Only, Link Pin/Ball Joint, Type 1, Set of 4

9692



98-4172-B

## STOCK SWAY BAR MOUNTING KIT

Mounting Kit, Stabilizer Bar (Both Sides), Type 1 66-77, Ghia 66-74

(Ref. P/N: 111 498 101A)



9615

## EMPI CAMBER COMPENSATOR

Designed to protect against over-camber on Swing Axle Bugs. Easily bolts to the bottom of the trans and features zinc plated steel components and urethane bushings. Fits all full synchro Swing Axle Bugs.

9615

Camber Compensator Kit

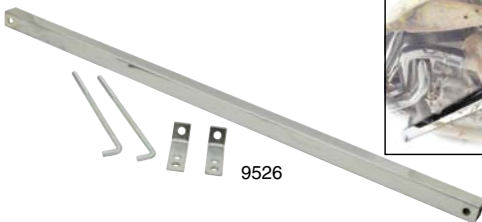

9526

## CHROME REAR ENGINE BRACE

Prevents wheel hop and engine flex by supporting rear of engine. Fits all Type 1 applications.

9526

Chrome Rear Engine Brace Kit



BUGPACK  
NEW!

## BUGPACK CHROME ENGINE BRACE

An original design from Bug Pack to eliminate drilling. This brace kit is designed to take the weight and torque of the engine and transmit it to the chassis. Eliminates suspension windup and wheel hop. Simple bolt-on installation and finished with a chrome plated bar and zinc plated hardware.

B651021

NEW!

Chrome Engine Brace Kit, 68-73



61-2500

## RABBIT & JETTA FRONT SUSPENSION BRACE

Stiffens the body on your Rabbit or Jetta and improves handling. Fits all Rabbits and Jetta 82-88 (Black).

61-2500

Suspension Brace, Upper



# SUSPENSION & STEERING

## EMPI PERFORMANCE OIL SHOCKS

EMPI Performance Oil Shocks bridge the gap between O.E. oil shocks and gas shocks. Lowered shocks offer modified travel to eliminate shock bottoming on lowered cars. Finished in bright white. EMPI shocks are sold individually boxed. We now include the compressed overall length (closed position) and also the fully extended (open position). P/N 9652 is supplied with two spacers to fit all the applications listed.

- 9650 EMPI Shock, Front, Link Pin, Lowered, Each
  - 9653 EMPI Shock, Front, Ball Joint, Lowered, Each
  - 9651 EMPI Shock, Front, Ball Joint, Stock Height, Each  
(Ref. P/N: 113 413 031E)
  - 9652 EMPI Shock, Front, Link Pin, Stock Height, Each  
(Ref. P/N: 113 513 031N)
- 
- 9652 EMPI Shock, Rear, All, 11 3/4"  
All I.R.S. / Swing Axle, Type 1, Ghia, Type 2, Type 3, Each  
(Ref. P/N: 113 513 031N)



	Closed	Open
9650	9 <sup>3</sup> / <sub>4</sub> "	14 <sup>5</sup> / <sub>8</sub> "
9651	14 <sup>1</sup> / <sub>2</sub> "	18"
9652	10 <sup>1</sup> / <sub>2</sub> "	16 <sup>1</sup> / <sub>4</sub> "
9653	10 <sup>1</sup> / <sub>2</sub> "	15 <sup>1</sup> / <sub>4</sub> "
9654	11 <sup>1</sup> / <sub>8</sub> "	14 <sup>5</sup> / <sub>8</sub> "
9655	15 <sup>1</sup> / <sub>4</sub> "	18"
9656	11 <sup>3</sup> / <sub>4</sub> "	16 <sup>1</sup> / <sub>4</sub> "
9657	11"	15 <sup>1</sup> / <sub>4</sub> "

## EMPI PERFORMANCE GAS SHOCKS

Gas Shocks are far superior and longer lasting than oil filled shocks. EMPI Gas Charged Performance Shocks will improve handling and stability because they adjust to varying road conditions automatically. On smooth roads the shock piston travels freely for a comfortable ride, on rough road surfaces the shock piston compresses more rapidly and the shock responds faster to maintain tire/road surface contact. EMPI's New Gas Charged Performance Shocks are specifically designed and engineered for the VW Beetle, with stock ride height or lowered suspensions. Finished in bright White. EMPI Shocks are sold individually boxed. We now include the compressed overall length (closed position) and also the fully extended (open position). P/N 9656 is supplied with two spacers to fit all the applications listed.

- 9654 EMPI Gas Shock, Front, Link Pin, Lowered, Each
  - 9657 EMPI Gas Shock, Front, Ball Joint, Lowered, Each
  - 9655 EMPI Gas Shock, Front, Ball Joint, Stock Height, Each
  - 9656 EMPI Gas Shock, Front, Link Pin, Stock Height, Each
- 
- 9656 EMPI Gas Shock, Rear, All, 12"  
All I.R.S. / Swing Axle, Type 1, Ghia, Type 2, Type 3, Each



## SUPER BEETLE LOWERING STRUTS & SPRINGS

Lower your Super Beetle and improve handling with these Adjustable Struts, Springs and Inserts. Struts allow car to be lowered from 2" to 4".

(Note: Struts are sold as pairs. Inserts are sold as each).

- 9626\* Super Beetle Adj. Lowering Strut, 71-73, Pair
  - 9627\* Super Beetle Adj. Lowering Strut, 74 & Later, Pair
- 
- 9628 Super Beetle Spring, All Super Beetle, Pair  
(Replacement Springs for Stock or Lowered Cars)
- 
- 9629 Strut Insert for P/N: 9626, Each
  - 9630 Strut Insert for P/N: 9627, Each

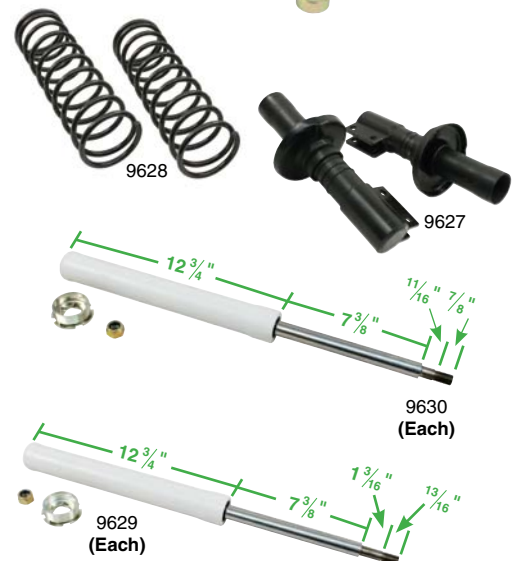

\*Struts cannot be installed w/o P/N: 9629/9630 Inserts.

\*Measurements are in the fully extended position

## COIL-ASSISTED SHOCKS

Adjustable coil-assisted shocks allow you to set your suspension to fit your needs. Available in Standard or Extended Length, and your choice of All-Chrome or Chrome Spring over Black shock. Supplied with spanner tool. Coil Diameter is 2 1/4" O.D. Fits Sedans Only. They should not be used as the only suspension source. They are designed to assist the shock in conjunction with torsion bars / leaves.



### Standard Length – 17" Non-Compressed/11 1/4" Compressed

<b>17-2815</b>	Front Link Pin, Rear All - Chrome, Skin Packed, Pair
<b>17-2815-8</b>	Front Link Pin, Rear All - Chrome, Boxed, Pair
<b>9570</b>	Front Link Pin, Rear All – Black/Chrome, Skin Packed, Pair
<b>9570-8</b>	Front Link Pin, Rear All – Black/Chrome, Boxed, Pair

### Extended Length – 22" Non-Compressed/17 1/4" Compressed

<b>17-2819</b>	Front Link Pin, Rear All, Extended - Chrome, Skin Packed, Pair
<b>17-2819-8</b>	Front Link Pin, Rear All, Extended - Chrome, Boxed, Pair

### Standard Length – 18" Non-Compressed/12 1/2" Compressed

<b>9571</b>	Front Ball Joint – Black/Chrome, Skin Packed, Pair
<b>9571-8</b>	Front Ball Joint – Black/Chrome, Boxed, Pair

## KYB GAS SHOCKS

Competition Proven KYB Gas-Charged shock absorbers featuring their patented Floating Dividing Piston that separates gas and fluid. All KYB Shocks are sold individually boxed.

### KYB SHOCKS - TYPE 1



<b>97-1009</b>	<a href="#">KYB 343144</a>	Front Link Pin, GR-2
<b>97-1019</b>	<a href="#">KYB 344068</a>	Front Link Pin, GR-2, Lowered
<b>97-1011</b>	<a href="#">KYB KG4521</a>	Front Link Pin, Gas-A-Just
<b>97-1008</b>	<a href="#">KYB 343143</a>	Front Ball Joint, GR-2
<b>97-1017</b>	<a href="#">KYB 343135</a>	Front Ball Joint, GR-2, Raised 3 1/2" Longer than stock
<b>97-1018</b>	<a href="#">KYB 343208</a>	Front Ball Joint, GR-2, Lowered
<b>97-1010</b>	<a href="#">KYB KG4520</a>	Front Ball Joint, Gas-A-Just
<b>97-1012</b>	<a href="#">KYB KG4605A</a>	Front Ball Joint, Gas-A-Just, Lowered
<b>97-3003</b> <small>NEW!</small>	<a href="#">KYB 363012</a>	Front Strut Cartridge, Super Beetle 71-73, GR-2
<b>97-3002</b>	<a href="#">KYB 363002</a>	Front Strut Cartridge, Super Beetle 73 1/2 - 79, GR-2
<b>97-1009</b>	<a href="#">KYB 343144</a>	Rear, All, GR-2
<b>97-1013</b>	<a href="#">KYB KG5529</a>	Rear, All, Gas-A-Just

### KYB SHOCKS - TYPE 2

<b>97-1011</b>	<a href="#">KYB KG4521</a>	Front, 55-79, Gas-A-Just
<b>97-1013</b>	<a href="#">KYB KG5529</a>	Rear, 55-67, Gas-A-Just
<b>97-1014</b>	<a href="#">KYB KG5530</a>	Rear, 68-79, Gas-A-Just (Also used for 8" Extended Shock Tower Link Pin Front Ends)

### KYB SHOCKS - TYPE 3

<b>97-1011</b>	<a href="#">KYB KG4521</a>	Front, All, Gas-A-Just
<b>97-1013</b>	<a href="#">KYB KG5529</a>	Rear, All, Gas-A-Just

## FRONT SHOCK MOUNT KIT

<b>98-4175-B</b>	Mount Kit, Front Shock Absorber, Type 1 66-77, Ghia 66-74 (Bulk P/N: 131 498 441)
------------------	--





# SUSPENSION & STEERING

## SWING AXLE BOOTS

### DELUXE

Deluxe Axle Boots feature Wide **Stainless Steel** Clamps, H.D. Hex-Head Plated Steel Bolts and Nylon-Insert Locking Nuts. Available in a variety of colors. Fits all Swing Axle applications.

- 9980 Deluxe Swing Axle Boot, Blue, Pair
- 9981 Deluxe Swing Axle Boot, Red, Pair
- 9983 Deluxe Swing Axle Boot, Yellow, Pair
- 9984 Deluxe Swing Axle Boot, Black, Pair



### STANDARD

Standard Swing Axle Boots come complete with installation hardware and are available in a variety of colors. These are the same high quality boots as the Deluxe Boots but with standard hardware and Narrow **Stainless Steel** Clamps.

- 9970 Swing Axle Boot - Blue, Pair
- 9971 Swing Axle Boot - Red, Pair
- 9973 Swing Axle Boot - Yellow, Pair
- 9974 Swing Axle Boot - Black, Pair



- 9979-8 Repl. Clamp Kit, Each, Poly Bagged (Incl. Clamp & Hardware for 1 Boot)

### STOCK-STYLE

Not to be confused with inferior quality boots offered by others. EMPI's stock style boots are manufactured in our molds, with high quality neoprene to give you the best boot available. Solid type is a favorite of racers and offers excellent flexibility with no chance of seam problems. Split types were designed for ease of installation and have become the most popular choice for everyday use. Both styles include all necessary hardware.

**\*Note: Solid boot requires the removal of bearing housings from axle tubes.**

- 9916 Stock Style Split Axle Boot Kit, Each (Bulk P/N: 111 598 021A) Bagged w/Hardware, Each
- 86-1091 Stock Style Split Axle Boot Only, Bulk, Each

- 9917 Stock Style Solid Axle Boot Kit, Each (Bulk P/N: 111 598 151) Boot & Clamps, Bagged, Each
- 9917-7 Stock Style Solid Axle Boot Only, Bulk, Each (Ref. P/N: 111 151 501)



## I.R.S. C.V. JOINT BOOTS W/FLANGE

Molded from high quality black Neoprene and feature integral mounting flange. Sets of 4 or each in bulk. See pages 449-455 for complete Volkswagen C.V. Boot coverage.

- 9994 I.R.S. Boot w/Flange, Type 1, Black, Set of 4
- 86-1084-V (86-1084-0) I.R.S. Boot w/Flange, Type 1, Black, Bulk, Each (Ref. P/N: 113 501 149) I.D. of Metal Flange 46.77mm
- 9989 I.R.S. Boot w/Flange, Late Type 2/4, Set of 4
- 86-1086-V (86-1086-0) I.R.S. Boot w/Flange, Late Type 2/4, Bulk, Each (Ref. P/N: 211 501 149) I.D. of Metal Flange 54.19mm



SEE PAGE 438 FOR ALL TYPES OF C.V. CLAMPS

86-1084

## NEW DRIVE AXLE ASSEMBLIES

EMPI's Axle Assemblies are assembled from all new top quality components manufactured by EMPI. See pages 446 for complete Volkswagen Drive Axle coverage. The same EMPI C.V. Joints and Boots used on these axle assemblies are available in kit form, see pages 447-455. Overall length is given for each axle.



<b>90-6900-C</b>	Type 1 & Ghia, w/I.R.S., 68-79, (16 3/8") (Ref. P/N: 113 501 201D)
<b>90-6905</b>	Thing, w/I.R.S., 73-75, (16 1/8") (Ref. P/N: 447 501 113)
<b>90-6903-C</b>	Type 2, M/T, w/I.R.S., 68-79, (18 3/4") (Ref. P/N: 211 501 203)
<b>90-6901</b>	Type 2, A/T, w/I.R.S., Left, 68-79, (18")
<b>90-6902</b>	Type 2, A/T, w/I.R.S., Right, 68-79, (19 7/8")
<b>90-6802</b>	Vanagon, M/T, 80-82, (21 1/2") (Ref. P/N: 251 501 203)
<b>90-6800</b>	Vanagon, A/T, Left, 80-82, (21") (Ref. P/N: 251 501 203A)
<b>90-6801</b>	Vanagon, A/T, Right, 80-82, (22 11/16")
<b>90-6805</b>	Vanagon, M/T, 83-92, (21 1/4") (Ref. P/N: 251 501 203G)
<b>90-6805</b>	Vanagon Syncro, Rear Both Sides, 86-92, (21 1/4") (Ref. P/N: 251 501 203G)
<b>90-6804-C</b>	Vanagon, A/T, Left, 83-92, (20 1/2") (Ref. P/N: 251 501 203E)
<b>90-6803-C</b>	Vanagon, A/T, Right, 83-92, (22 5/16") (Ref. P/N: 251 501 204B)
<b>90-6900-C</b>	Type 3 (Exc. Auto), M/T, w/I.R.S., 69-73, (16 3/8") (Ref. P/N: 113 501 201D)
<b>90-6907</b>	Type 3, A/T, w/I.R.S., Left, 69-73, (15 5/16")
<b>90-6906</b>	Type 3, A/T, w/I.R.S., Right, 69-73, (17 1/4")
<b>90-6800</b>	411, 412, w/I.R.S., 71-74, (21") (Ref. P/N: 251 501 203A)



## EMPI CONSTANT VELOCITY JOINTS AND KITS

Replace worn and clanking Velocity Joints. Our kits include everything needed to do the job right. Includes: EMPI C.V. Joint, Boot, Clamps, Snap Rings and Grease. See pages 447-448 for complete Volkswagen Constant Velocity Joint coverage.

<b>87-9916-K</b>	C.V. Joint Kit, Type 1 & 3, Vanagon Syncro (Front Inner) 90mm, Each
<b>87-9916</b>	C.V. Joint Only, Type 1 & 3, Vanagon Syncro (Front Inner) 90mm O.D., 6875" Balls, Each (EMPI Replacement Joint for 113 501 331)
<b>87-9917-K</b>	C.V. Joint Kit, Type 2 & Vanagon, 100mm, Each
<b>87-9917</b>	C.V. Joint Only, Type 2 & Vanagon, 100mm O.D., .750" Balls, Each (EMPI Replacement Joint for 211 501 331B)

See 98-5084-B for Off-Road Type 2 Joint on page 215



## I.R.S. BOOTS W/FLANGE

<b>9994</b>	I.R.S. Boot w/Flange, Type 1, Black, Set of 4
<b>86-1084-V (86-1084-0)</b>	I.R.S. Boot w/Flange, Type 1, Black, Bulk, Each (Ref. P/N: 113 501 149)
<b>9989</b>	I.R.S. Boot w/Flange, Late Type 2/4, Set of 4
<b>86-1086-V (86-1086-0)</b>	I.R.S. Boot w/Flange, Late Type 2/4, Bulk, Each (Ref. P/N: 211 501 149)

See page 217 for proper installation procedure if C.V. Joints come apart.

SEE PAGE 438-439 FOR ALL TYPES OF C.V. CLAMPS



# SUSPENSION & STEERING

## EMPI HI-PERFORMANCE C.V. JOINTS

Larger C.V. Joints make it possible to run increased loads and axle angles. EMPI's Hi-Performance C.V. Joints offer all the quality benefits a Hi-Performance C.V. Joint should. They include **Chromoly Cages** and hardened alloy inner/outer races that are precision machined, ground, and hand inspected. Our kits include everything needed to do the job right. Includes: EMPI C.V. Joint, Boot, Clamps, Grease and **NEW Spiral Lock Clip included with all joints for 930.**

- 87-9469-B**      **EMPI, Porsche 930 C.V. Joint Only**, 108mm O.D., .875" Balls, Each  
28 Spline Inner Race, (Solid Outer Race, **w/Chromoly Cage**)  
(EMPI Replacement Joint for 930 332 034 00E)
- 87-9469-K**      **EMPI, Porsche 930 C.V. Joint Kit**, 108mm, Each,  
28 Spline Inner Race, (Incl. P/N: 86-9301 Boot & P/N: 86-9302 Flange)
- 87-9470-B**      **EMPI, Porsche Off-Road 930 C.V. Joint Only**, 108mm O.D., .875" Balls, Each  
28 Spline Inner Race, (Solid Outer Race, **w/Chromoly Cage**)  
(The fit between balls and tracks is very loose to allow for maximum angles)
- 98-5097-B**      **EMPI, Porsche 934 C.V. Joint Only**, 128mm O.D., 1.000" Balls, Each  
Large 33 Spline Inner Race, (Solid outer race, **w/Chromoly Cage**)
- 98-5098-B**      **EMPI, Porsche 934 C.V. Joint Only**, 128mm O.D., 1.000" Balls, Each  
Large 33 Spline Inner Race, (Solid outer race, **w/Chromoly Cage**)  
(The fit between balls and tracks is very loose to allow for maximum angles)
- 98-5084-B**      **EMPI Off-Road Type 2 C.V. Joint Only**, 100mm O.D., .750" Balls, Each  
33 Spline Inner Race, (Solid outer race, **w/Chromoly Cage**)



87-9469-B

**Chromoly Cages!**



98-5097-B

## EMPI HI-PERFORMANCE LIGHTENED C.V. JOINTS

Larger C.V. Joints make it possible to run increased loads and axle angles, but in turn add to the mass rotating weight. Reducing this weight can improve acceleration, much like lightening the engine flywheel. EMPI's Hi-Performance Lightened C.V. Joints offer all the quality benefits a Hi-Performance C.V. Joint should. They include **Chromoly Cages** and hardened alloy inner/outer races that are precision machined ground and hand inspected. A reduction in weight as a result of custom machining the O.D. of the outer race adds the finishing touch for a true hi-performance C.V. Joint. This machining process also aids in cooler operating temperatures of the joint in extreme use situations.

- 98-5094-B**      **EMPI H.P. Lightened 930 C.V. Joint w/Chromoly Cage**,  
108mm O.D., .875" Balls, 28 Spline Inner Race  
(The fit between balls and tracks is very loose to allow for maximum angles)
- 98-5096-B**      **EMPI H.P. Lightened 934 C.V. Joint w/Chromoly Cage**,  
128mm O.D., 1.000" Balls, Large 33 Spline Inner Race  
(The fit between balls and tracks is very loose to allow for maximum angles)

98-5094-B

**Chromoly Cages!**



98-5096-B

## LOBRO / GKN C.V. JOINTS

In addition to our EMPI made C.V. Joints, we also offer Lobro stock replacement C.V. Joints for those that choose to go with the stock replacement manufacturer. GKN motorsports C.V. Joints .

- 98-5093-B**      New Lobro 930 C.V. Joint, 108mm O.D., .875" Balls, Each  
(Ref. P/N: 930 332 034 00) 28 Spline Inner Race



98-5093-B

**SEE PAGE 438 FOR ALL TYPES OF C.V. CLAMPS**



## I.R.S. C.V. JOINT BOOT KITS (BOXED)

These kits include EMPI's high quality neoprene boot. Each kit is packaged in our distinctive 3-Color Trilingual box. Kit includes Boot, Moly Grease Pack, Hardware and deluxe kits include 6 C.V. Bolts.



86-1084-D

- 86-1084-D** C.V. Joint Boot Kit, Type 1
- 86-1084-1** Deluxe C.V. Joint Boot Kit, Type 1 (w/ Bolts)  
(Ref. P/N: 113 598 201)



86-1086-1

- 86-1086-D** C.V. Joint Boot Kit, Type 2
- 86-1086-1** Deluxe C.V. Joint Boot Kit, Type 2 (w/ Bolts)  
(Ref. P/N: 251 598 201)



86-1084-1



## C.V. BOLTS

These hardened aircraft quality C.V. Bolts hold it all together. Available with Allen or 12 Pt. Heads for most popular applications ([Bulk quantities available on all part numbers](#)).

- 16-2409** Bolt for Type 1 C.V., M8 x 1 15/16", 12 Pt. Internal, Set of 6
- 87-7701** Bulk Bolt for Type 1 C.V., M8 x 1 15/16", 12 Pt. Internal, Each  
(Ref. P/N: 113 501 229D)

- 16-2410** Bolt for Type 1 & 2 C.V., 3/8" - 24 x 1 3/4", Allen Head, Set of 6
- 16-2412** Bolt for Type 1 & 2 C.V., 3/8" - 24 x 1 3/4", 12 Pt., External, Set of 6

- 16-2413** Bolt for 930 C.V., 3/8" - 24 x 2 1/4", 12 Pt., External, Set of 6
- 16-2413-7** **NEW!** Bulk Bolt for 930 C.V., 3/8" - 24 x 2 1/4", 12 Pt., External, Each

- 16-2415** Bolt for 930 C.V., 3/8" - 24 x 2 5/16", 12 Pt., External, Set of 6 (For P/N: 86-9312 Flange)
- 16-2414** Bolt for 934 C.V., 7/16" - 20 x 2 7/16", 12 Pt., External, Set of 6

## C.V. JOINT BOLT SOCKET

Available for 6-Point and 12-Point 8mm Hex C.V. joint bolts.



5796

- 5796** C.V. Joint 12-Point Hex Socket, 8mm, 3/8" Drive
- 5797** C.V. Joint 6-Point Hex Socket, 6mm, 3/8" Drive

## C.V. JOINT GREASE

EMPI Moly C.V. Joint Grease meets the rigid factory fill requirements set by all major C.V. Joint manufacturers. EP-2 (Extreme Pressure) Additive provides superior protection against seizure under extreme pressure loads. Use EMPI Moly Grease for all long travel play car or racing applications.



86-3009



86-3000/86-3005

- 86-3000** Moly Grease for C.V. Joints, 4 oz. packet
- 86-3005** Moly Grease for C.V. Joints, 3 oz. packet
- 86-3009** Red C.V. Grease, 14oz tube
- 86-3039\*** 400 lb. Plastic Lined Drum of Grease
- 86-3027** 35 lb. Drum of Grease



86-3039 / 86-3027

**\*Shipped via Truck Only**  
**Grease CANNOT be shipped via AIR**

**SEE PAGE 438 FOR ALL TYPES OF C.V. CLAMPS**





# SUSPENSION & STEERING

## CV JOINT END CAP

87-5870 **NEW!** C.V. Joint End Cap, Fits 87-9469-B, 87-9470-B, 98-5094-B, and 98-5093-B



## TORQUE DISTRIBUTION WASHER

87-5871 **NEW!** Torque Distribution 930 Washer for 108mm Joint, Each

87-5080 Torque Distribution T-1 Washer for 90mm Joint, Each  
(Ref. P/N: 113 501 329)

87-5081 Torque Distribution T-2 Washer for 100mm Joint, Each  
(Ref. P/N: 211 501 357)

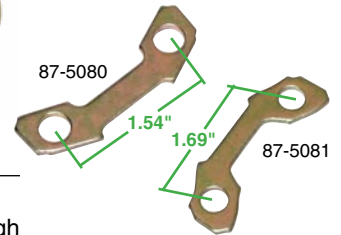

## EMPI RACING C.V. COMPONENTS

You can't win if you do not finish. In mild applications stock C.V joints are fine. If you have a high performance engine or go off-road then step up with our conversion flanges and stub axles. Rugged terrain usage and race applications require the use of our race hardened C.V. components as well. Manufactured by EMPI and hardened for superior strength, these Races and Cages hold up under the most demanding conditions. Cages and Races are designed for EMPI C.V. Joints.

### C.V. RACES

16-2630 Type 1 Race Only, (Repl. to fit 87-9916), Each  
16-2609 Type 1 Hardened C.V. Race, for 5/8" Balls, Each  
16-2607 Type 1 Hardened C.V. Race, for 11/16" Balls, Each

16-2632 Type 2 Race Only, (Repl. to fit 87-9917), Each  
16-2634 Type 2 Race Only, (Repl. to fit 87-5084-B), Each

16-2628 930 C.V. Race Only, (Repl. to fit 87-9469-B), Each  
16-2629 930 Race Prep C.V. Race Only, (Repl. to fit 87-9470-B), Each  
16-2635 930 Race Prep C.V. Race Only, (Repl. to fit 98-5094-B), Each  
16-2640 **NEW!** Chromoly 930 Race Only, (Fits 87-9469-B), Each

16-2606 934 C.V. Race Only, (Repl. to fit 98-5096-B, 98-5097-B), Each  
16-2627 934 Race Prep C.V. Race Only, (Repl. to fit 98-5098-B), Each

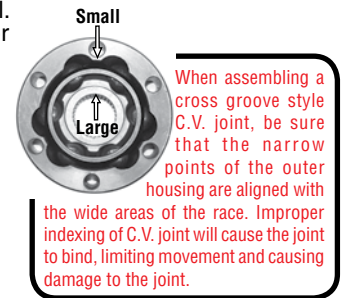

When assembling a cross groove style C.V. joint, be sure that the narrow points of the outer housing are aligned with the wide areas of the race. Improper indexing of C.V. joint will cause the joint to bind, limiting movement and causing damage to the joint.

### 930 C.V. RACE "KIT"

This special made 930 race is designed specifically for high strength, durability and long wheel travel in applications that require such attributes. The race is supplied with special .874" balls so that the race / ball combo allows for a "loose" high travel joint. The design of this kit is such that either new or used 930 EMPI joints can benefit from this kit and the C.V. Joint can be made to operate as if it was a custom ground / deburred / modified joint. (.874" balls can also be ordered separately, see P/N: 16-2619).

16-2611 930 Race w/Balls Kit, Each



### CHROMOLY CAGES

These high quality chromoly cages are the same as supplied in our EMPI hi-performance lightened C.V. joints. Chromoly construction adds the necessary strength and durability while radiused windows and surface ground tolerances provide the quality fit that EMPI is known for. These cages are a required item if you want the most operating angle from your 930 or 934 C.V. Joint and if you want to eliminate breakage from inferior designed cages.

16-2615 930 H.P. Chromoly C.V. Cage, for 7/8" (.875") Balls, (Can also be used with .874" balls). Fits all EMPI C.V. Joints for 930, Each

16-2616 934 H.P. Chromoly C.V. Cage for 1" Balls. Fits all EMPI C.V. Joints for 934, Each. Fits all EMPI C.V. Joints for 934, Each

16-2633 Type 2 Chromoly C.V. Cage Only (Repl. to fit 98-5084-B), Each



### C.V. CAGES

16-2617 Type 1 Cage Only (Repl. to fit 87-9916), Each

16-2631 Type 2 Cage Only (Repl. to fit 87-9917), Each



### C.V. BALLS

16-2624 C.V. Ball, 5/8", for Type 1 Joints, 24 pcs.

16-2619 C.V. Ball, .874", for 930 Joints, 24 pcs.

16-2620 C.V. Ball, .873" (.002" undersize), for 930 Joints, 24 pcs.

16-2621 C.V. Ball, 7/8" (Standard Size - .875"), for 930 Joints, 24 pcs.

16-2622 C.V. Ball, 1" (Standard Size), for 934 Joints, 24 pcs.



## FORGED TRANSMISSION DRIVE FLANGES

EMPI's conversion drive flanges and stub axles are necessary items to upgrade your suspension to larger C.V. Joints. All EMPI drive flanges are **forged from chromoly** high strength steel that is then precision machined and heat treated to handle years of off-road abuse. Some flanges feature C.V. bolt holes that are made with 3/8" - 24 threads to accommodate heavy duty bolts. Use these flanges in conjunction with EMPI stub axles, heavy duty cages, races, boots and boot flanges to upgrade an existing suspension to a long travel, high performance suspension!

- 16-2299** Type 1 Trans. to Type 2 Joint, 33 Splines, 36mm Nose, M8 Threads, Pair
- 16-2301** Type 1 Trans to 930 Joint, 33 Splines, 36mm Nose, 3/8" - 24 Threads, Pair
- 16-2302** 002 Type 2 Trans to 930 Joint, 37 Splines, 42mm Nose, 3/8" - 24 Threads, Pair
- 16-2303** 091 Type 2 Trans to 930 Joint, 40 Splines, 45mm Nose, 3/8" - 24 Threads, Pair
- 98-5140-B** Plug, Final Drive, Type 2, 69-79, Each  
Fits P/N's 16-2301, 16-2302 and 16-2303  
**New Tooling For Tight Fit**

(Ref. P/N: 002 517 289A)

- 17-2930** Poly Drive Flange Plug, Type 1, Pair
- 17-2931** Poly Drive Flange Plug, Type 2, Pair

Poly Plugs may require some fitting by sanding or filing.



**Forged Chromoly!**

## FORGED CONVERSION STUB AXLES

EMPI's Conversion Stub Axles feature all the same high quality elements as our drive flanges; Including **forged chromoly** construction, precision CNC machining and following the proper heat treat specifications. Converting any stock or aftermarket trailing arm that uses stock I.R.S. bearings and seals has never been easier. Fully compatible with drum or disc brakes. EMPI also offers Micro Stub versions for 930 and 934 applications.

- 16-2304** Conv. Stub Axle for Type 1 to Type 2 Joint, 8mm Threads, Each
- 16-2306** Conv. Stub Axle for Type 1 to 930 C.V. Joint, 3/8" - 24 Threads, Each
- 16-2307** Conv. Stub Axle for Type 1 to Type 2 Joint, Short for 5-Lug Drum, 8mm Threads, Each
- 16-2308** Standard Size Stub Axle for Type 1, 8mm Threads, Each  
(Ref. P/N: 113 501 231)



**Forged Chromoly!**

## FORGED MICRO STUB AXLES

- 16-2310** Micro Stub Axle w/Washer For 930 C.V. Joint, 3/8" - 24 Threads, Each
- 16-2311** Micro Stub Axle w/Washer For 934 C.V. Joint, 7/16" - 20 Threads, Each
- 16-2421** Spindle Nut M24 x 1.5, Each  
(Bulk P/N: 311 501 221)





# SUSPENSION & STEERING

## EMPI C.V. BOOT GREASE FLANGES

Machined Billet Aluminum Grease Flanges allow you to grease your C.V. Joints without removing the boots. May require longer bolts.

- 86-9315 Grease Flange, Bus – for 8mm Bolts.
- 86-9316 Grease Flange, 930 – for 10mm / 3/8" Bolts.
- 86-9317 Grease Flange, 934 - for 12mm / 7/16" Bolts.

All Flanges have 2 Grease Fittings and are 10.20mm Thick

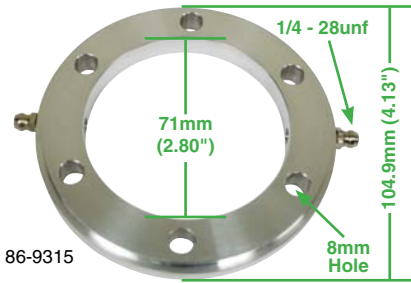

86-9315

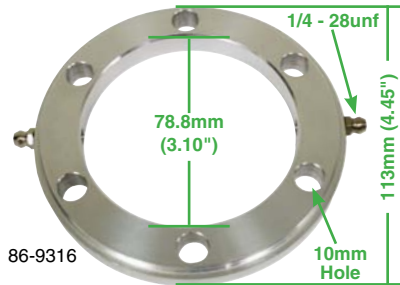

86-9316

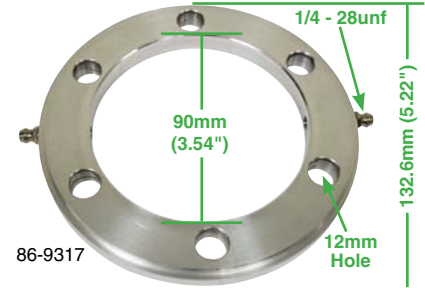

86-9317

## 934 LEATHER OFF-ROAD OVER-BOOT

Tough, heavy Leather Over-Boot will protect the inner rubber boot from damage. Used as an Over-Boot with 86-9318 Dual-Boot Flange. May be used on 930 and other applications.

- 86-9323 Leather Over-Boot Only - use with P/N 86-9318 Dual-Boot Flange.

## 934 DUAL-BOOT SYSTEM

Special 2-Piece Flange attaches Inner Rubber Boot which holds the grease to keep the C.V. Joint lubricated and the Outer Leather Boot protects the Inner Boot from Damage. P/N 86-9318 2-Piece Flanges are attached together with supplied bolts. P/N 86-9322 Rubber Inner Boot attaches to Inner Flange. P/N 86-9323 Leather Out-Boot Attaches to Outer Flange for maximum protection. Uses standard EMPI C.V. Bolts (P/N 16-2414). Bolts not included.

- 86-9318 934 Type C.V. Joint Dual-Boot Flange, Set. Use w/ P/N 86-9322 or P/N 86-9321 C.V. Boot and P/N 86-9323 Leather Over-Boot.
- 86-9322 934 Type C.V. Joint Off-Road Inner C.V. Boot, Ea. Use with P/N 86-9318 Dual-Boot Flange or P/N 86-9313 Flange. May also be used w/ P/N 86-9302 and P/N 86-9312 Flange.

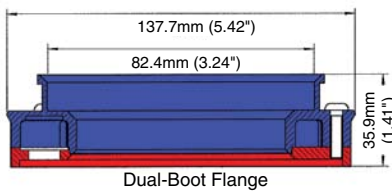

Dual-Boot Flange



86-9318

Bolt Not Included

## OFF-ROAD C.V. JOINT BOOTS

- 86-9320 930 Type C.V. Joint Off-Road C.V. Boot. Use with P/N 86-9302 Flange or P/N 86-9312 Billet Aluminum Flange.
- 86-9321 930 Type C.V. Joint Off-Road C.V. Boot. Use with P/N 86-9313 Flange.



86-9320



86-9321

## BILLET ALUMINUM BOOT RETAINER AND C.V. FLANGE

The cleanest and most efficient way yet to secure a 930 C.V. boot. The boot is captured between an aluminum inner flange and a great looking billet outer ring. No more clamps or zip ties. Works on both ends, longer bolts are available in this section.

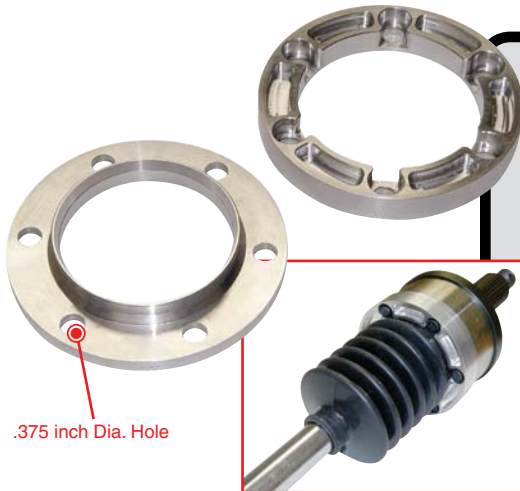

**86-9312** 930 Billet Aluminum Boot Retainer and C.V. Flange, Set (Uses C.V. Boot 86-9301)

**16-2415** Bolt for 930 C.V., 3/8" - 24 x 2 5/16", 12 Pt., External, Set of 6 (For P/N: 86-9312 Flange)

## OFF-ROAD C.V. JOINT BOOTS & KITS

For over 20 years EMPI has been producing High Quality Neoprene C.V. Boots. With tens of millions sold, it can be said we know how to make a quality C.V. Boot! All EMPI off-road C.V. Boots are injection molded using only high quality neoprene blended material that is made to EMPI's strict specifications. Rest assured that EMPI C.V. Boots are the best boots available for your off-road car. Boots, flanges and components are available separately in bulk or in kit form. Kits are supplied boxed complete with C.V. Boot, flange, moly grease pack and H.D. tie wrap clamps. (See pages 438 & 439 for additional tie wraps and clamps).



930 Type C.V. Joint Off-Road Boot Kit w/Flange Uses P/N 16-2415 Bolts. (Not Included)



930 Boot Only for P/N: 86-9300-D (Bulk)

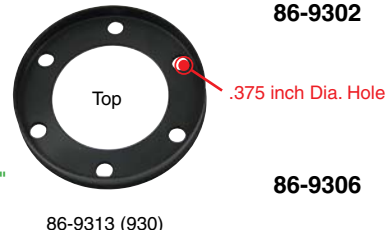

930 Flange Only for P/N: 86-9300-D (Bulk) Uses P/N 16-2415 Bolts. (Not Included)



Boot Only, fits over 930 Type C.V. Joint (108mm) and Flange (Bulk) (86-9302 flange or 86-9313 flange must be used to retain the C.V. Joints)

Metal Flange for 930 Over the C.V. Boot Uses P/N 16-2415 Bolts. (Not Included)



# SUSPENSION & STEERING

## OFF-ROAD C.V. JOINT BOOTS & KITS (Continued)

**86-9309-D** 934 Type Off-Road Boot Kit w/Flange  
Uses P/N 16-2414 Bolts. (Not Included)

**86-9307** 934 Boot Only for P/N: 86-9309-D (Bulk)

**86-9308** 934 Flange Only for P/N: 86-9309-D (Bulk)  
Uses P/N 16-2414 Bolts (Not Included).  
**(Cleared for travel of balls)**



**86-9312-D** 934 Type C.V. Joint Over the C.V. Boot Kit  
Uses P/N 16-2414 Bolts. (Not Included)  
(C.V. Joint fits into the flange,  
boot fits over the joint & flange)  
**This boot will fit both sizes of axle bars,  
just cut the small end of boot off for  
larger bar**

**86-9311** Boot Only, 934 Over the C.V. Joint (128mm)  
Over 8" tall. For P/N: 86-9312-D (Bulk)

**86-9310** Flange Only, 934 Over the C.V. Boot  
for P/N: 86-9312-D (Bulk)  
Uses P/N 16-2414 Bolts. (Not Included)  
**Notched for long travel**



**86-9303-D** 100mm Off-Road Boot Kit w/Flange,  
for Type 2 (Bus), C.V. Joint  
Uses P/N 16-2410 or P/N 16-2412 Bolts.  
Not Included)

**86-9304** Type 2 Boot Only for P/N: 86-9303-D  
(Will also fit P/N: 86-9302 Flange) (Bulk)

**86-9305** Type 2 Flange Only for P/N: 86-9303-D (Bulk)  
10.3mm Holes  
**Standard bolts will work with these large holes  
or use P/N 16-2410 or P/N 16-2412 Bolts.  
(Not Included)**





## EMPI CHROMOLY I.R.S. RACE AXLES

Engineered and designed to twist or spool up like a torsion bar to avoid damage to the transmission final drive and to keep the axle from snapping under extreme or race loads. All of these EMPI axles are made from **4340 chromoly** and feature high strength cold formed / rolled splines. Special silver zinc plating ensures these axles far outlast and outperform all of the competitors! For hi-performance, drag racing and off road conditions, these axles are the only way to go.

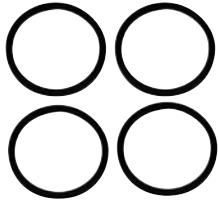

16-2262  
(930 Axles)  
Spiral Locks

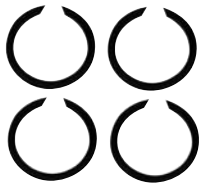

16-2260  
(Type 1 & 2 Axles)  
Circlips

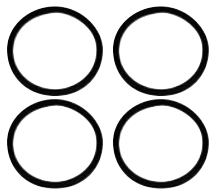

16-2261  
(934 Axles)  
Spiral Locks

16-2201	16 1/4", for Type 1 Trans./Type 1 & 2 Joints/Type 1 Suspension, Pair
16-2202	15 5/8", for Type 2 Trans./Type 1 & 2 Joints/Type 1 Suspension, Pair
16-2203	15 5/8", for Type 2 Trans./930 C.V. Joints/Type 1 Suspension, Pair
16-2204	18 3/4", for Type 1 Trans./Type 1 & 2 Joints/+5 3/4" Rear Sect., Pair
16-2205	18 3/4", for Type 1 Trans./930 C.V. Joints/+5 3/4" Rear Sect., Pair
16-2206	19 1/4", for Type 2 Trans./Type 1 & 2 Joints/3 x 3 Arms, Pair
16-2207	19 1/4", for Type 2 Trans./930 C.V. Joints/3 x 3 Arms, Pair
16-2200	16 1/4" Axle, 28 Splines, Pair
16-2209	16 3/4" Axle, 28 Splines, Pair
16-2208	16 3/4" Axle, 33 Splines, Pair
16-2225	17 1/2" Axle, 28 Splines, Pair
16-2224	17 1/2" Axle, 33 Splines, Pair
16-2211	20 1/4" Axle, 28 Splines, Pair
16-2210	20 1/4" Axle, 33 Splines, Pair
16-2213	21 3/8" Axle, 28 Splines, Pair
16-2212	21 3/8" Axle, 33 Splines, Pair
16-2215	22" Axle, 28 Splines, Pair
16-2214	22" Axle, 33 Splines, Pair
16-2217	23" Axle, 28 Splines, Pair
16-2219	24" Axle, 28 Splines, Pair
16-2221	25" Axle, 28 Splines, Pair
16-2223	26" Axle, 28 Splines, Pair
16-2227	27" Axle, 28 Splines, Pair
16-2228	28" Axle, 28 Splines, Pair
16-2262	Replacement Spiral Locks for 930 Axles, 4 pcs.
16-2260	Replacement Circlips for Type 1 & 2 Axles, 4 pcs.
16-2261	Replacement Spiral Locks for 934 Axles, 4pcs

**4340  
Chromoly**



**28 Splines:**  
930 C.V. Joint  
31.00mm O.D.

**33 Splines:**  
Type 1 & 2 Joints  
26.95mm O.D.



16-2230

**4340  
Chromoly**

## HI-PERFORMANCE CHROMOLY SWING AXLES

Some of the strongest axles available. Constructed from **4340 chromoly**, these swing axles are available in standard (26 11/16"), long (28 7/16") and short (23 1/2") lengths. Drag racing, sand or off-road, they will give you the dependability you need. Must use Torque Wrench, do not use Impact Gun to tighten axle nut.

16-2230	Hi-Performance Swing Axle, Standard, 61-66 Type 1, 26 11/16", Each
16-2231	Hi-Performance Swing Axle, Long, 68 Type 1, 28 7/16", Each
16-2237	Hi-Performance / Drag Race Swing Axle, Standard, Type 1, 23 1/2", Each



# SUSPENSION & STEERING

## EMPI CHROMOLY I.R.S. RACE AXLE KITS

EMPI has taken the guess work out of putting together your high performance I.R.S. axles. Complete axle kits are now available and come with our chromoly race axles, nylon ties, boots, C.V. joints, flanges, and grease. These axle kits are not assembled and come in an eye catching full color box.

- 16-2232 Type 2 Axle Kit, 19 1/4" with 33 Spline Axles
- 16-2233 Type 2 Axle Kit, 15 5/8" with 33 Spline Axles
- 16-2234 Type 2 Axle Kit, 20 1/4" with 33 Spline Axles
- 16-2235 930 Axle Kit, 19 1/4" with 28 Spline Axles
- 16-2236 930 Axle Kit, 20 1/4" with 28 Spline Axles
- 16-2238 930 Axle Kit, 22" with 28 Spline Axles
- 16-2239 930 Axle Kit, 23" with 28 Spline Axles



16-2235

## REPLACEMENT SWING AXLE BEARING HOUSINGS

For 66 and earlier, short axle. Sold in pairs. Bearing not included.

- 16-9923 Swing Axle Bearing Housing, Pair (Boxed)



16-9923

## CHROME 36MM AXLE NUT

High quality rear axle nut. Chrome plated or Gold Zinc for good looks. Great for applications where the axle nut is visible.

- 16-2420 Chrome 36mm Axle Nut, Each
- 16-2421 Zinc 36mm Axle Nut, Each
- 16-2421-7 Stock Zinc Plated 36mm Axle Nut, Bulk, Each  
(Ref P/N: 311 501 221)



16-2420  
(21.6mm Tall)



16-2421-7  
(18mm Tall)

## HI-PERFORMANCE AXLE SPACER KITS

Stock axle spacers just won't hold up to the abuse of off-road and hi- performance applications. Or when replacing the axle bearings you might as well up grade at the same time. Available for both swing axle and I.R.S. (I.R.S. Kit includes stub axle bearing spacers).

- 16-2400 Axle Spacer Kit for I.R.S., 6 pcs.
- 16-2401 Axle Spacer Kit for Swing Axle, 4 pcs.



16-2400

16-2401

## CHROME SPRING PLATE CAPS

Chrome Spring Plate Caps for good looks. Both styles available; Swing axle for shorter style torsion bars and I.R.S. style for medium and long torsion bar use.

See page 205 for Urethane Bushings. Use bushing P/N 16-5133 for P/N 9569.

- 9545 Chrome Spring Plate Caps - Swing Axle, Pair
- 9569 Chrome Spring Plate Caps - I.R.S., Pair



9569



9545

## REAR AXLE SEAL KIT

Includes: Seal, Gaskets, O-Rings and Cotter Key for complete replacement of your old worn seals. Fits Swing Axle and I.R.S.

- 9910 Rear Axle Seal Kit  
(Bulk P/N: 311 598 051B)



# SUSPENSION & STEERING



**WARNING:** It is extremely important that brake lines be installed by a trained mechanic. Proper length of each line in relation to wheel travel and steering angle is critical to avoid brake failure. Equally important is brake lines must be free flowing and have no contamination. Additionally, all calipers must be bled properly, regardless of kit purchased. Do not attempt brake line or caliper installation without the experience to properly evaluate all of these issues.

All bearing races must be **PRESSED** into rotors.

## BOLT-ON DISC BRAKE KITS

Converting your '68 & later Type 1 (except S/B) from drum to disc is made simple with this true Bolt-On Kit. Featuring heavy duty cast brackets that bolt directly to your stock spindles – then calipers to the brackets. Available in 4x130 with 14x1.5mm threads, Double-Drilled 5x130 with 14x1.5mm threads / 5x4.75" with 12mm threads and Blank (not drilled) for custom wheel applications. Hardware is included. Wheel studs are not included. **These kits will only work with stock-style, drum brake spindles.**



- 22-2983 Ball Joint Bolt-On Disc Brake Kit, 4x130 with 14x1.5mm threads
- 22-2984 Ball Joint Bolt-On Disc Brake Kit, Blank (not drilled)
- 22-2985 Ball Joint Bolt-On Disc Brake Kit, Double-Drilled 5x130 with 14x1.5mm threads / 5x4.75" with 12mm threads



- 22-2986 Link Pin Bolt-On Disc Brake Kit, 4x130 with 14x1.5mm threads
  - 22-2991 Link Pin Bolt-On Disc Brake Kit, Blank (not drilled)
  - 22-2990 Link Pin Bolt-On Disc Brake Kit, Double-Drilled 5x130 with 14x1.5mm threads / 5x4.75" with 12mm threads
- All Link Pin Kits include conversion bearings and special BJ-style clamps. This eliminates double nuts.**
- 17-2795 Replacement Inner Bearing for 22-2986, 22-2990, and 22-2991 Kit, Each (Fits EMPI Kit Only)
  - 17-2796 Replacement Outer Bearing for 22-2986, 22-2990, and 22-2991 Kit, Each (Fits EMPI Kit Only)

## ZERO OFF-SET WIDE-5 DISC BRAKE KITS

EMPI's special brake rotor and caliper mounting bracket combine to give you a premium disc brake upgrade, using your existing front spindles, with near Zero offset – no loss of tire clearance. You can have the stopping power of disc brakes and still bolt on your favorite Wide-5 (5x205) wheels without using adapters! Kits come complete with master cylinder, brake lines, wheel bearings & seals and all necessary hardware. Link Pin Kit comes with a Single Master Cylinder with no residual valve and Ball Joint Kits come with a '67 & later Dual Master Cylinder. **These kits will not work with drop spindles – will only work with stock-style, drum brake spindles. Must use with 15" wheels.**



- 22-2880 Zero Off-Set Front Disc Brake Kit Link Pin, 5-Lug, 5x205 to '65 w/Single M/C
- 22-2885 Zero Off-Set Front Disc Brake Kit Ball Joint, 5-Lug, 5x205 to '66-67 w/Dual M/C
- 22-2895 Zero Off-Set Front Disc Brake Kit Ball Joint, 5-Lug, 5x205 to '68 & Later w/Dual M/C
- 22-2961-B Front Brake Rotor, 5/205, Link Pin, to 65, Each
- 22-2962-B Front Brake Rotor, 5/205, Ball Joint, 66 on, Each
- 98-6019-B Dual Master Cylinder, '67 & later (Does not include reservoir), Each
- 98-6022-B Single Master Cylinder (Does not include reservoir), Each
- 22-2892 Replacement Brake Pad Set for P/N: 22-2880/85/95, Set of 4

See pg. 247 for information

## DROP SPINDLE DISC BRAKE KITS

Drop your front stance 2 1/2" and add the benefits of disc brakes all in one package. Kits come with all necessary components including rotors, calipers & pads, wheel bearings & seals and hardware. Link Pin kits include brake lines, thrust washers and spindle nuts. Available in 4x130 with 14x1.5mm threads, Double-Drilled 5x130 with 14x1.5mm threads / 5x4.75" with 12mm threads and Blank (not drilled) for custom wheel applications. Wheel studs are not included. Spindles are off-set 1/4", which widens your track a total of about 5/8". **Ball Joint Kits require the use of '69 & later tie rod ends. Must use with 15" wheels.**



- 22-2881 Front Disc Brake Kit, Link Pin, 4x130 with 14x1.5mm threads
- 22-2882 Front Disc Brake Kit, Link Pin, Double-Drilled 5x130 with 14x1.5mm threads / 5x4.75" with 12mm threads
- 22-2923 Front Disc Brake Kit, Link Pin, Blank (not drilled)
- 22-2886 Front Disc Brake Kit, Ball Joint, 4x130 with 14x1.5mm threads (Requires 69-on Style Tie Rod Ends)
- 22-2887 Front Disc Brake Kit, Ball Joint, Double-Drilled 5x130 with 14x1.5mm threads / 5x4.75" with 12mm threads (Requires 69-on Style Tie Rod Ends)
- 22-2924 Front Disc Brake Kit, Ball Joint, Blank (not drilled) (Requires 69-on Style Tie Rod Ends)
- 22-2890 Repl. Brake Pad Set for P/N: 22-2881/2882/2886/2887/2923/2924, Set of 4

Check out our  
**TECH VIDEOS**





# SUSPENSION & STEERING

**WARNING:** It is extremely important that brake lines be installed by a trained mechanic. Proper length of each line in relation to wheel travel and steering angle is critical to avoid brake failure. Equally important is brake lines must be free flowing and have no contamination. Additionally, all calipers must be bled properly, regardless of kit purchased. Do not attempt brake line or caliper installation without the experience to properly evaluate all of these issues.

## **BALL JOINT DISC BRAKE KITS WITH STOCK-STYLE SPINDLES**

The stopping power and safety of Disc Brakes in a bolt-on kit, including new stock-height Ball Joint Spindles. Complete kit includes backing plates, calipers w/pads and rotors. Requires purchase of bearings and seals for '66-'68 Type 1. Available in 4x130 with 14x1.5mm threads, Double-Drilled 5x130 with 14x1.5mm threads / 5x4.75" with 12mm threads and Blank (not drilled) for custom wheel applications. Wheel studs are not included. **'66-'68 will require the use of '69 & later tie rod ends. Must use with 15" wheels.**

- 22-2850** Front Disc Brake Kit, Ball Joint  
4x130 with 14x1.5mm threads
- 22-2981** Front Disc Brake Kit, Ball Joint  
5x130 with 14x1.5mm threads / 5x4.75" with 12mm threads
- 22-2921** Front Disc Brake Kit, Ball Joint  
Blank (not drilled)
- 22-2851** Bearing and Seal Kit (6 pcs.)
- 22-2890** Replacement Brake Pads, Set of 4
- 98-1153-B** Replacement Brake Rotor, 4x130 w/ 14x1.5mm threads, Ea  
(Ref. P/N: 113 407 075)
- 22-2963-7** Repl. Brake Rotor, Double-Drilled  
5x130 with 14x1.5mm threads / 5x4.75" with 12mm threads
- 98-1150-B** Replacement Caliper w/ Pads, Each  
(Ref. P/N: 311 615 107/8)
- 22-2849-B** Replacement Backing Plate, Each  
(Ref. P/N: 102 405 593) [See pages 236-239 for all Replacement Rotors](#)



All bearing races must be **PRESSED** into rotors.



## **SUPER BEETLE FRONT DISC BRAKE KIT**

The stopping power and safety of Disc Brakes in a bolt-on kit. Complete kit includes mounting brackets, calipers w/pads, rotors and two 10" metal brake lines to complete the installation. We recommend purchase of new bearings and seals. Available in 4x130 with 14x1.5mm threads, Double-Drilled 5x130 with 14x1.5mm threads / 5x4.75" with 12mm threads and Blank (not drilled) for custom wheel applications. Wheel studs are not included. **Must use with 15" wheels.**

- 22-2855** S/B Front Disc Brake Kit  
4x130 with 14x1.5mm threads
- 22-2982** S/B Front Disc Brake Kit  
5x130 with 14x1.5mm threads / 5x4.75" with 12mm threads
- 22-2922** S/B Front Disc Brake Kit, Blank (not drilled)
- 22-2851** Bearing and Seal Kit (6 pcs.)
- 22-2890** Replacement Brake Pads, Set of 4
- 98-1153-B** Replacement Brake Rotor, 4x130 with 14x1.5mm threads  
(Ref. P/N: 113 407 075)
- 22-2963-7** Repl. Brake Rotor, Double-Drilled  
5x130 with 14x1.5mm threads / 5x4.75" with 12mm threads
- 98-1150-B** Replacement Caliper w/ Pads, Each  
(Ref. P/N: 311 615 107/8)



[See pages 236-239 for all Replacement Rotors](#)

# SUSPENSION & STEERING



**WARNING:** It is extremely important that brake lines be installed by a trained mechanic. Proper length of each line in relation to wheel travel and steering angle is critical to avoid brake failure. Equally important is brake lines must be free flowing and have no contamination. Additionally, all calipers must be bled properly, regardless of kit purchased. Do not attempt brake line or caliper installation without the experience to properly evaluate all of these issues.

All bearing races must be **PRESSED** into rotors.

## 2 1/2" DROP SPINDLE 5/205 FRONT DISC BRAKE KITS

A dropped front stance and classic 5/205 wheels combined with modern brake technology. That's what you'll get with EMPI's Drop Spindle 5/205 brake kit. Kit includes spindles, calipers, pads, hoses, bearings, grease seals, clamp nuts, and hardware.

**Widens your track a total of about 5/8".**

**22-2925** Drop Spindle 5/205 Front Disc Brake Kit, Link Pin

**22-2926** Drop Spindle 5/205 Front Disc Brake Kit, Ball Joint  
(Requires 69-on Style Tie Rod Ends)



See Pages 236-239 for Replacement Rotors.



22-2926

## ZERO OFF-SET WIDE-5 REAR DISC BRAKE KITS - WITH EMERGENCY BRAKE

An affordable and durable alternative to billet racing brakes is here! No need for adapters if you want to run wheels with the early VW 5 on 205 bolt pattern. The 1 pc. rotor design of these brake kits offers a bolt on kit to upgrade a street car to rear wheel disc brakes, or an off-road play car the option to have a firm and responsive brake system without needless extra parts to get in the way. All kits come complete with 1-piece rotors, calipers, pads, mount brackets, emergency brake cables and all necessary hardware and gaskets to complete the installation. Deluxe kits feature heavy duty cast brackets. Order Deluxe kits by choosing the '-F' part number. **If you do not want an Emergency Brake, install without cables. Must use with 15" wheels.**

### 5 LUG (5/205) DISC BRAKES WITH E-BRAKE

**22-2905** Zero Off-set Wide-5 Rear Disc Brake Kit w/E-Brake, Swing Axle, 58-67

**22-2905-F** DELUXE Zero Off-set Wide-5 Rear Disc Brake Kit w/E-Brake Swing Axle, 58-67

**22-2906** Zero Off-set Wide-5 Rear Disc Brake Kit w/E-Brake, I.R.S., 68-72, Swing Axle '68

**22-2906-F** DELUXE Zero Off-set Wide-5 Rear Disc Brake Kit w/E-Brake, I.R.S., 68-72, Swing Axle '68

**22-2907** Zero Off-set Wide-5 Rear Disc Brake Kit w/E-Brake, I.R.S., 73 & Later

**22-2907-F** DELUXE Zero Off-set Wide-5 Rear Disc Brake Kit w/E-Brake, I.R.S., 73 & Later

**22-2891** Pads for Forged Bracket Kits

**22-2966** Pads for Steel Bracket Kits

**22-2972-B** Replacement Rear Brake Rotor, 5/205, Each (I.R.S. requires P/N: 22-5281-7 Spacer)

**22-5281-7** Replacement Spacer for I.R.S. Rotor, Each (Ref. P/N: 111 501 303B)



22-2905



Steel Brackets



HD Cast Brackets "F" Kits

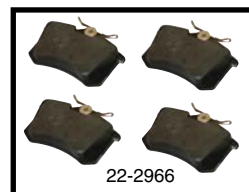

22-2966

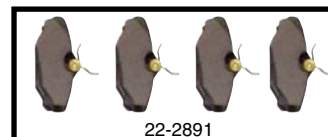
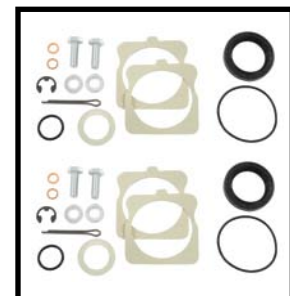

22-2891



# SUSPENSION & STEERING

## RACE-TRIM MICRO STUB BRAKE KITS

State of the art suspension is just one step away! Micro-stub brake systems are necessary if you are going to use a rear suspension that is different from a VW style trailing arm arrangement. This Race-Trim kit utilizes the best of the best in both components and materials used. 4-piston brake calipers, vented rotors, forged chromoly stub axles, forged hub assemblies, 6061 T-6 aluminum alloy rotor hats & wheel adapters. This combination gives you the winning edge, whether it's for racing or just an all out turbo long-travel sand car! Kits come complete ready for fab-in installation and are sold as a set. In addition we also offer a Micro-Arm flange tube to facilitate installation of the Race-Trim Micro Stub brake kit to a tubular trailing arm. Bolt pattern is 5 on 205. [\(See pages 244-245 for additional details on this item\).](#)

- 16-2510 Race-Trim Micro Stub Brake Kit, for 930 C.V. Joints
- 16-2511 Race-Trim Micro Stub Brake Kit, for 934 C.V. Joints
- 16-2516 Mount Tube Only for Race-Trim Micro Stub Kit, Pair (Not Installed)  
(Not included in brake kits)
- 16-2525-7 Replacement Caliper, Each, w/o pads
- 16-2525-6 Replacement Pads, Two Pair
- 16-2510-2 Replacement Left Rotor Only, Each
- 16-2510-7 Replacement Right Rotor Only, Each
- 16-2510-1 Replacement Hub Bearing Assembly, Each
- 16-2510-4 Replacement Wheel Adapter, Each
- 16-2510-3 Replacement Aluminum Hub, Each
- 16-2510-5 Replacement Cap, Each
- 16-2510-8 Replacement Bracket, Each
- 16-2413 Repl. 3/8" x 24, 12 point, grade 8 (930), 6 pcs.
- 16-2414 Repl. 7/16" x 20, 12 point shouldered, grade 10.9 (934), 6 pcs.
- 16-2310 Microstub Axle w/ washer for 930 C.V. Joint, Each
- 16-2311 Microstub Axle w/ washer for 934 C.V. Joint, Each
- 16-2421 Spindle Nut for Micro Stub Axles, M24 x 1.5, Each



16-2510-1

16-2510-5



16-2510-4



16-2421

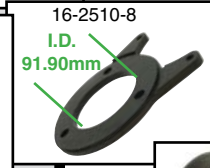

16-2510-8

I.D.  
91.90mm



16-2510-3



16-2516

Not Included in Kits

## RACE-TRIM FRONT DISC BRAKE KITS OFF-ROAD & SAND CARS W/ COMBO SPINDLES

State of the art braking! This Race-Trim kit utilizes the best of the best in both components and materials used. Billet Wilwood calipers and pads, 5/205 Bolt Pattern. Supplied with 14mm Studs, Chrome Lug Nuts and Polished Aluminum Center Caps. Bearing races are pressed into hubs.

- 16-2517 Race-Trim Off-Road Front Disc Brake Kit, for Combo Spindles
- 16-2517-3 Replacement Rotor, Left / Right Only, Each
- 16-2517-6 Replacement Caliper, Each, w/o Pads
- 16-2517-7 Replacement Pads, Two Pair



**NEW! NOT REBUILT**



22-2952

## DISC BRAKE SPINDLES (STOCK BALL JOINT)

A welcomed addition when rebuilding your ball joint front end with disc brakes. These all new spindles are precision ground and accept 69-on bearings, seals and tie rods. The left side is drilled for the speedo cable. **NEW, NOT RE-BUILT**

**22-2952** New Spindles, Stock Ball Joint, For 4/130, Pair  
(Ref. P/N: 113 405 311D/2D)



22-2950

## 2 1/2" DROP SPINDLES FOR LINK PIN & BALL JOINT, DRUM AND DISC BRAKE FRONT ENDS

EMPI drop spindles are brand new units, not re-manufactured old cores! CNC machined to exact tolerances. These spindles feature 1/4" outwards offset. Clearance is usually not an issue. Made only for 4-Lug VW (4/130) and 5-Lug Porsche (5/130) disc brake applications. These spindles are the first step to a brake system upgrade while giving you the built-in ability to lower your car an automatic 2 1/2" just by bolting them on. Link Pin spindles utilize stock tie rod holes while the ball joint spindles require 69-on inner wheel bearings and tie rod ends. Both spindles use original steering geometry so the ride and handling of the car is not negatively effected.



22-2951

**22-2950** 2 1/2" Drop Spindle, Link Pin, Disc Brake for 4/130 & 5/130, Pr.

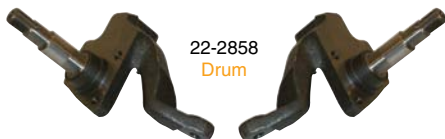

22-2858  
Drum

**22-2951** 2 1/2" Drop Spindle, Ball Joint, Disc Brake for 4/130 & 5/130, Pr.  
(Requires 69-on Style Tie Rod Ends)

**22-2858** 2 1/2" Drop Spindle, Link Pin, Drum Brake, to 65, For 5/205, Pr.



22-2859  
Drum

**22-2859** 2 1/2" Drop Spindle, Ball Joint, Drum Brake, 66-77, For 5/205 and 4/130, Pr.  
(Requires 69-on Inner Wheel Bearings and Tie Rod Ends)



22-2955

## REPLACEMENT 2 1/2" DROP SPINDLES

Replacement 2 1/2" Drop Spindles for P/N 22-2925 and P/N 22-2926 5x205 Disc Brake Kits. Driver side is drilled for the speedo cable.

**22-2955** Replacement Drop Ball Joint Spindles (5x205), Pair  
**22-2954** Replacement Drop Link Pin Joint Spindles (5x205), Pair



# SUSPENSION & STEERING

## EMPI 68-79 TYPE 2 DROP SPINDLES

Brand New – not re-manufactured Drop Spindles to lower your Bus 2". Lower your front end 2" while keeping the same suspension geometry and maintaining the stock ride. Designed to replace your original spindles without modification. Fits 68 to 79 but requires the use of 73 & Later Brake Components. These Spindles widen your track by approximately 3/4" per side.

Stock / OEM 14" Wheel or EMPI 5x112 Wheels will fit:  
10-1082 Gasser, 10-1084 Cosmo, 9731 / 9697 BRM, 9694 / 9728 911 Alloy, 9749 Dish, 9662 / 9696 / 9695 GT-5

**22-2948** Bus 2" Drop Spindles, Pair, 68-79 Type 2  
(Must use 73 & Later Brake Components)



## TYPE 2 BRAKE ROTOR - FRONT

Hi-Quality replacement Front Brake Rotor for 73-79 or Disc Brake Conversion for 68-79 Bus.

**18-1014** **NEW!** Brake Rotor, Front, Type 2, 73-79, Each  
(Ref. P/N: 211 615 301B)



## TYPE 2 FRONT HUB ASSEMBLY

Replacement Front Hub Assembly for 71-79 Bus or Disc Brake Conversion for 68-79 Bus.

**18-1019** **NEW!** Front Hub Assembly, Type 2, 71-79, Each  
(Ref. P/N: 211 405 579)



## TYPE 2 FRONT GREASE SEAL - INNER

Front Grease Seal for 68-79 Bus/Transporter. Pressed into Brake Drum or Hub Assembly (Disc Brakes).

**18-1035** **NEW!** Grease Seal, Front, Type 2, 68-79, Each  
(Ref. P/N: 211 405 641D)



## TYPE 2 FRONT WHEEL BEARING - INNER

Front Inner Wheel Bearing for 64-79 Bus/Transporter.

**98-4620-B** Inner Wheel Bearing, Front, Type 2, 64-79, Each  
(Ref. P/N: 211 405 625)



## TYPE 2 FRONT WHEEL BEARING - OUTER

Front Outer Wheel Bearing for 64-79 Bus/Transporter.

**98-4623-B** Outer Wheel Bearing, Front, Type 2, 64-79, Each  
(Ref. P/N: 211 405 645D)





**NEW!**  
99-4372



## **TYPE 2 BOLT - BRAKE ROTOR TO HUB**

8.8 Grade Socket Head M8X20 Bolt for Rotor to Hub. Replacement for 73-79 or for Disc Brake Conversion for 68-79 Bus. Zinc Plated.

**99-4372** **NEW!** Bolt – Rotor to Hub, Type 2, 73-79, Each  
(Ref. P/N: N 014 779 1)



**NEW!**  
18-1033

## **TYPE 2 MASTER CYLINDER & RESERVOIR KIT**

This Type 2 Brake Cylinder comes with a Reservoir that attaches directly for easy installation. No adaptors or spacers – this Master Cylinder was designed for the reservoir. Perfect for replacement for 73-79 Bus with no need to source a stock reservoir or for your 68-79 Disc Brake Conversion. Without Servo/Power Brakes. May require some modification.

**18-1033** **NEW!** Master Cylinder & Reservoir Kit, Type 2, 73-79, Each



98-9600-B

## **TYPE 2 BRAKE LINE 260MM (10.25")**

260mm Brake Line when needed for Type 2 Disc Brake Conversion for 68-79 Bus / Transporter.

**98-9600-B** Steel Brake Line, 260mm (10.25"), Each  
(Ref. P/N: 113 611 735D)



**NEW!**  
18-1011

## **TYPE 2 FRONT BRAKE CALIPER – UNIVERSAL LEFT/RIGHT**

This Type 2 Front Brake Caliper is universal and fits both Left and Right sides. Comes loaded with Brake Pads, designed with the brake line port in the center and the shoulder bolt has been replaced by 2 standard bolts for easy installation as replacement for 73-79 Bus or Disc Brake Conversion for 68-79 Bus.

**18-1011** **NEW!** Front Brake Caliper w/Pads and Bolts,  
Type 2 73-79, Vanagon 80-85, Each  
(Ref. P/N: 211 615 107/108)



**NEW!** 18-1013

## **TYPE 2 REPLACEMENT BRAKE PADS**

Front Replacement Brake Pads for 73-79 Bus.

**18-1013** **NEW!** Front Brake Pads, Type 2, 73-79, Vanagon 80-85, Set  
(Ref. P/N: 251 698 151A)



**NEW!**  
98-4253-B

## **TYPE 2 STEERING DAMPER**

Replacement Steering Damper for 55-79 Bus/Transporter.

**98-4253-B** **NEW!** Steering Damper, Type 2, 55-79, Each  
(Ref. P/N: 211 425 021A)



# SUSPENSION & STEERING

## EMPI FORGED H.D. KING PIN SPINDLE KIT

Complete Spindle, Knuckle and Pin set with beefed up **Forged** spindles. Gussets forged into the spindle and steering arm for added strength. Great for your Baja or Buggy. **FORGED** Gussets built into the spindle and steering arm. Gussets on the knuckles have been machined for steering clearance. Grease fittings are installed. The speedometer cable passes through a hole that is in the left side spindle. Set up for stock link pins.

**22-2976** FORGED H.D. King Pin Spindle Kit, Pair



## SPINDLE COMPONENTS

- 98-4051-B** Spindle Nut, Left  
(Ref. P/N: 111 405 671)
- 98-4052-B** Spindle Nut, Right  
(Ref. P/N: 111 405 672)
- 9616** Aluminum Linkpin Clamp Nut, Pair
- 17-2795** King Pin Conversion Bearing, Inner, Each  
O.D. = 1.977", I.D. = .9845"
- 17-2796** King Pin Conversion Bearing, Outer, Each  
O.D. = 1.570", I.D. = .7875"
- 98-1156-B** Axle Seal  
(Ref. P/N: 321 501 641)
- 17-2797** Combo Spindle Bearing, Inner, Each  
O.D. = 2.437", I.D. = 1.251" (Race Ref. #15244)
- 17-2798** Combo Spindle Bearing, Outer, Each  
O.D. = 2.052", I.D. = 1.0005"
- 98-5021-B** Axle Seal  
(Ref. P/N: 113 501 315H)



## REPLACEMENT PRESS IN BALL JOINT SPINDLES

Available for ball joint only. Machining required. Sold in pairs. Right and left hand thread. Left side is drilled for speedo cable.

**16-9914** Replacement Ball Joint Spindle, Pair

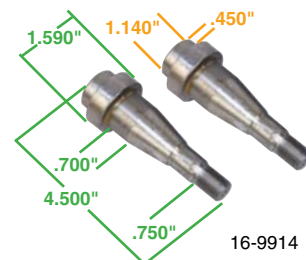

**WARNING:** It is extremely important that brake lines be installed by a trained mechanic. Proper length of each line in relation to wheel travel and steering angle is critical to avoid brake failure. Equally important is brake lines must be free flowing and have no contamination. Additionally, all calipers must be bled properly, regardless of kit purchased. Do not attempt brake line or caliper installation without the experience to properly evaluate all of these issues.



## REAR DISC BRAKE KITS - WITHOUT EMERGENCY BRAKE

For off-road and play cars where emergency brake provisions are not required, we offer these brake kit options. Standard kits feature stamped steel brackets while our Deluxe kits feature heavy duty cast brackets. Order Deluxe kits by choosing the 'F' part number. All kits feature O.E. style brake calipers that make poor brake performance a thing of the past. Available in 4x130 with 14x1.5mm threads, Double-Drilled 5x130 with 14x1.5mm threads / 5x4.75" with 12mm threads and Blank (not drilled) for custom wheel applications. All kits include rotors, calipers w/pads, mounting brackets and hardware. **Wheel studs are NOT included. Must use with 15" wheels. To order the DELUXE kits with H.D. cast mounting brackets, add "F" to the part number.**



- 22-2862** Rear Disc Brake Kit, 4x130 with 14x1.5mm threads Swing Axle, 58-67
- 22-2862-F** DELUXE Rear Disc Brake Kit, 4x130 with 14x1.5mm threads Swing Axle, 58-67
- 22-2910** Rear Disc Brake Kit, Double-Drilled 5x130 with 14x1.5mm threads 5x4.75" with 12mm threads, Swing Axle, 58-67
- 22-2910-F** DELUXE Rear Disc Brake Kit Double-Drilled 5x130 with 14x1.5mm threads, 5x4.75" with 12mm threads, Swing Axle, 58-67
- 22-2917** Rear Disc Brake Kit, I.R.S., Blank (not drilled) **Swing Axle, 58-67**
- 22-2917-F** DELUXE Rear Disc Brake Kit, Blank (not drilled) **Swing Axle, 58-67**
- 22-2861** Rear Disc Brake Kit, 4x130 with 14x1.5mm threads I.R.S. 68 & later & Swing Axle 68
- 22-2861-F** DELUXE Rear Disc Brake Kit, 4x130 with 14x1.5mm threads I.R.S. 68 & later & Swing Axle 68
- 22-2911** Rear Disc Brake Kit, Double-Drilled 5x130 with 14x1.5mm threads, 5x4.75" with 12mm threads, I.R.S. 68 & later & Swing Axle 68
- 22-2911-F** DELUXE Rear Disc Brake Kit Double-Drilled 5x130 with 14x1.5mm threads, 5x4.75" with 12mm threads, I.R.S. 68 & later & Swing Axle 68
- 22-2916** Rear Disc Brake Kit, I.R.S., Blank (not drilled) I.R.S. 68 & later & Swing Axle 68
- 22-2916-F** DELUXE Rear Disc Brake Kit, Blank (not drilled) I.R.S. 68 & later & Swing Axle 68

See page 236-239 for Replacement Rotors  
See page 239-241 for Replacement Pads

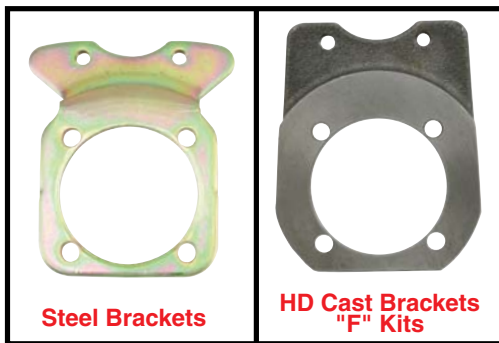





# SUSPENSION & STEERING

**WARNING:** It is extremely important that brake lines be installed by a trained mechanic. Proper length of each line in relation to wheel travel and steering angle is critical to avoid brake failure. Equally important is brake lines must be free flowing and have no contamination. Additionally, all calipers must be bled properly, regardless of kit purchased. Do not attempt brake line or caliper installation without the experience to properly evaluate all of these issues.

## REAR DISC BRAKE KITS - WITH EMERGENCY BRAKE

For Street Cars where emergency brake provisions are required, we offer these brake kit options. Standard kits feature stamped steel brackets while our Deluxe kits feature heavy duty cast brackets. Order Deluxe kits by choosing the '-F' part number. All kits feature O.E. style brake calipers that make poor brake performance a thing of the past. Available in 4x130 with 14x1.5mm threads, Double-Drilled 5x130 with 14x1.5mm threads / 5x4.75" with 12mm threads and Blank (not drilled) for custom wheel applications. All kits include rotors, calipers w/pads, mounting brackets and hardware. **Wheel studs are NOT included. Must use with 15" wheels. To order the DELUXE kits with H.D. cast mounting brackets, add "F" to the part number.**

- 22-2865** Rear Disc Brake Kit, 4x130 with 14x1.5mm threads, Swing Axle, 58-67
- 22-2865-F** DELUXE Rear Disc Brake Kit, 4x130 with 14x1.5mm threads, Swing Axle, 58-67
  
- 22-2912** Rear Disc Brake Kit, Double-Drilled 5x130 with 14x1.5mm threads / 5x4.75" with 12mm threads, Swing Axle, 58-67
- 22-2912-F** DELUXE Rear Disc Brake Kit, Double-Drilled 5x130 with 14x1.5mm threads / 5x4.75" with 12mm threads Swing Axle, 58-67
  
- 22-2918** Rear Disc Brake Kit, Blank (not drilled), Swing Axle, 58-67
- 22-2918-F** DELUXE Rear Disc Brake Kit, Blank (not drilled), Swing Axle 58-67

---

- 22-2870** Rear Disc Brake Kit, 4x130 with 14x1.5mm threads, I.R.S. 68 & later & Swing Axle 68
- 22-2870-F** DELUXE Rear Disc Brake Kit, 4x130 with 14x1.5mm threads, I.R.S. 68 & later & Swing Axle 68
  
- 22-2913** Rear Disc Brake Kit, Double-Drilled 5x130 with 14x1.5mm threads / 5x4.75" with 12mm threads I.R.S. 68 & later & Swing Axle 68
- 22-2913-F** DELUXE Rear Disc Brake Kit, Double-Drilled 5x130 with 14x1.5mm threads / 5x4.75" with 12mm threads I.R.S. 68 & later & Swing Axle 68
  
- 22-2919** Rear Disc Brake Kit, Blank (not drilled), I.R.S. 68 & later & Swing Axle 68
- 22-2919-F** DELUXE Rear Disc Brake Kit, Blank (not drilled), I.R.S. 68 & later & Swing Axle 68

---

- 22-2871** Rear Disc Brake Kit, 4x130 with 14x1.5mm threads, I.R.S. 73-79
- 22-2871-F** DELUXE Rear Disc Brake Kit, 4x130 with 14x1.5mm threads, I.R.S. 73-79
  
- 22-2914** Rear Disc Brake Kit, Double-Drilled 5x130 with 14x1.5mm threads / 5x4.75" with 12mm threads, I.R.S. 73-79
- 22-2914-F** DELUXE Rear Disc Brake Kit, Double-Drilled 5x130 with 14x1.5mm threads / 5x4.75" with 12mm threads, I.R.S. 73-79
  
- 22-2920** Rear Disc Brake Kit, Blank (not drilled), I.R.S. 73-79
- 22-2920-F** DELUXE Rear Disc Brake Kit, Blank (not drilled), I.R.S. 73-79

See page 236-239 for Replacement Rotors

See page 239-241 for Replacement Pads

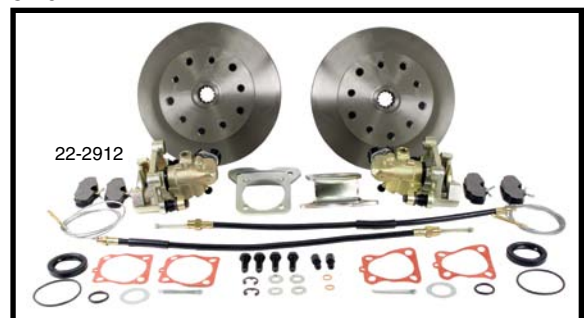
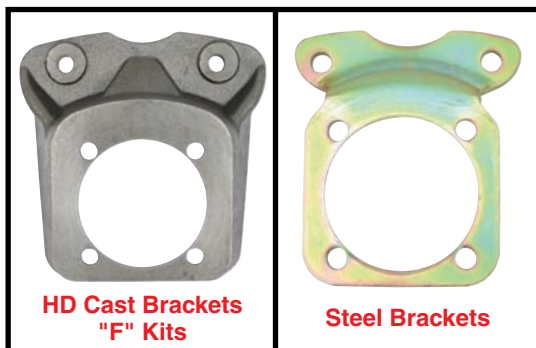

# SUSPENSION & STEERING



**WARNING:** It is extremely important that brake lines be installed by a trained mechanic. Proper length of each line in relation to wheel travel and steering angle is critical to avoid brake failure. Equally important is brake lines must be free flowing and have no contamination. Additionally, all calipers must be bled properly, regardless of kit purchased. Do not attempt brake line or caliper installation without the experience to properly evaluate all of these issues.

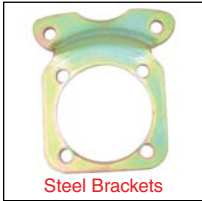

## WIDE TRACK REAR DISC BRAKE KITS with 5/205 ROTORS

Our "Wide Track" rear disc brake kits are for Off-Roaders who are looking to increase their rear wheel "track". Kits are available with, or without emergency brakes, and come complete with 1-piece minimum offset 1" extra wide rotors, calipers, pads, mounting brackets, emergency cables (where applicable), and all necessary hardware and gaskets for the complete installation. Rotors are threaded for 12mm and 14mm studs. **To order the DELUXE kits with H.D. cast mounting brackets, add "F" to the part number.**

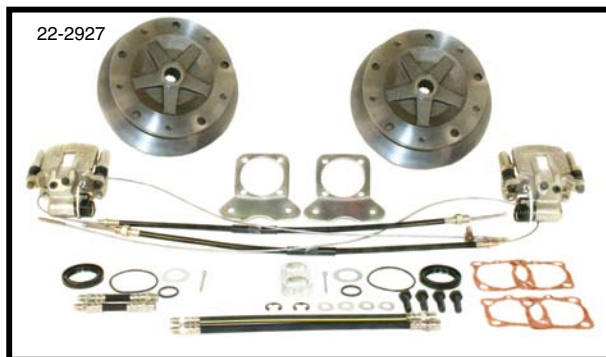

**22-2927** Wide Rear Disc Brake Kit w/ E-Brake, 5/205, I.R.S. 68-72, S/Axle 1968

**22-2927-F** DELUXE Wide Rear Disc Brake Kit w/ E-Brake, 5/205, I.R.S. 68-72, S/Axle 1968

**22-2928** Wide Rear Disc Brake Kit w/ E-Brake, 5/205, Swing Axle 58-67

**22-2928-F** DELUXE Wide Rear Disc Brake Kit w/ E-Brake, 5/205, Swing Axle 58-67



**22-2929** Wide Rear Disc Brake Kit w/o E-Brake, 5/205, I.R.S. 68-72, S/Axle 1968

**22-2929-F** DELUXE Wide Rear Disc Brake Kit w/o E-Brake, 5/205, I.R.S. 68-72, S/Axle 1968

**22-2930** Wide Rear Disc Brake Kit w/o E-Brake, 5/205, Swing Axle 58-67

**22-2930-F** DELUXE Wide Rear Disc Brake Kit w/o E-Brake, 5/205, Swing Axle 58-67

**22-2973-B** Replacement Rotor, 5/205 Rear Wide Track, Each I.R.S., Requires 22-5281-7 Spacer

99% of the calls we received concerning problems with brake installation comes down to 1 problem...**AIR IN THE LINES**. No one wants to hear it, after having bled the system 2 or 3 times...but spongy pedal, pads dragging, etc., almost always is the cause of air trapped in the system.

Be sure to Bench Bleed a new master cylinder if installed. There are a few different '1-Man Bleeders' available - Mityvac and others. Use our new Quick Bleeders...make it easy on yourself and your helpers.

If installing new Disc Brake Calipers, rotate them to where the bleeder is around 12 O'Clock for bleeding...easier to get the air going straight up...then rotate them into position when you are done.

When all else fails, take the car to a professional for bleeding and adjusting. Small price to pay if you do not have the patience!



# SUSPENSION & STEERING

## COMPONENTS USED IN EMPI BRAKE KITS

**17-2753-7** **NEW!** Bulk Brake Bracket, Ea  
 Brackets used in the following Brake Kits, Right and Left are the same. Sold Each in Bulk  
 For Kit P/N: 22-2986, 22-2990 and 22-2991

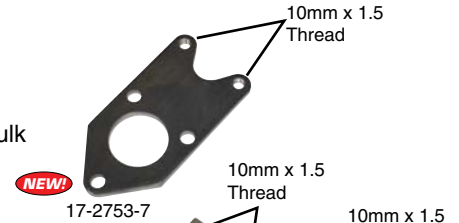

**22-2845-7** **NEW!** Bulk Cast Brake SB Bracket, Pr  
 Brackets used in the following Brake Kits, Right and Left are different. Sold in Pairs, Bulk  
 For Kit P/N: 22-2855, 22-2922 and 22-2982

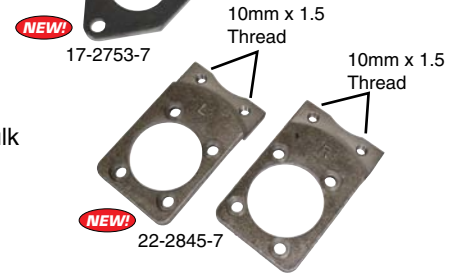

**22-2847** **NEW!** Bulk Brake Bracket, Ea  
 Brackets used in the following Brake Kits, Right and Left are the same. Sold Each in Bulk  
 For Kit P/N: 22-2861, 22-2862, 22-2910, 22-2911, 22-2916, 22-2917, 22-2929 and 22-2930

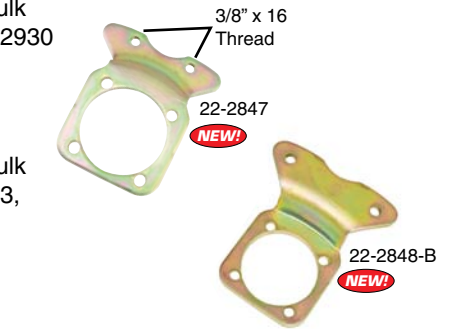

**22-2848-B** **NEW!** Bulk Brake Bracket, Ea  
 Brackets used in the following Brake Kits, Right and Left are the same. Sold Each in Bulk  
 For Kit P/N: 22-2865, 22-2870, 22-2871, 22-2905, 22-2906, 22-2907, 22-2912, 22-2913, 22-2914, 22-2918, 22-2919, 22-2920, 22-2927 and 22-2928



**22-2857** **NEW!** Bulk Cast Brake Bracket, Ea  
 Brackets used in the following Brake Kits, Right and Left are the same. Sold Each in Bulk  
 For Kit P/N: 22-2861-F, 22-2862-F, 22-2910-F, 22-2911-F, 22-2916-F, 22-2917-F, 22-2929-F and 22-2930-F

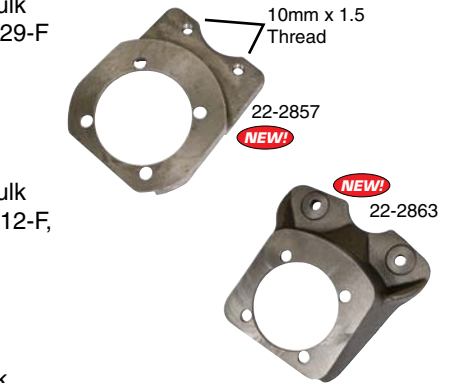

**22-2863** **NEW!** Bulk Cast Brake Bracket, Ea  
 Brackets used in the following Brake Kits, Right and Left are the same. Sold Each in Bulk  
 For Kit P/N: 22-2865-F, 22-2870-F, 22-2871-F, 22-2905-F, 22-2906-F, 22-2907-F, 22-2912-F, 22-2913-F, 22-2914-F, 22-2918-F, 22-2919-F, 22-2920-F, 22-2927-F and 22-2928-F



**22-2880-B** **NEW!** Bulk Cast Brake Bracket, Pr  
 Brackets used in the following Brake Kit, Right and Left are different. Sold in Pairs, Bulk  
 For Kit P/N: 22-2880

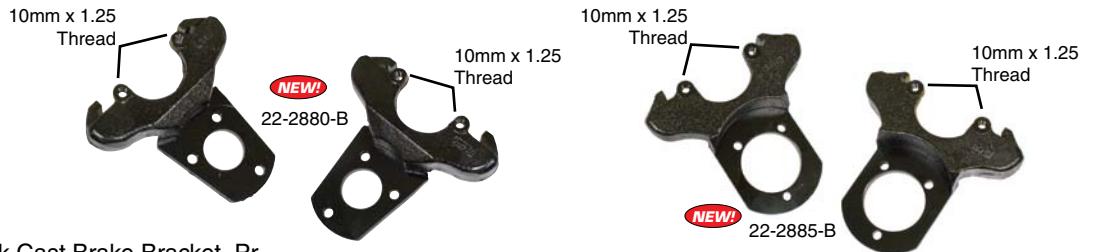

**22-2885-B** **NEW!** Bulk Cast Brake Bracket, Pr  
 Brackets used in the following Brake Kits, Right and Left are different. Sold in Pairs, Bulk  
 For Kit P/N: 22-2885 and 22-2895



**22-2975-7** **NEW!** Bulk Cast Brake Bracket, Ea  
 Brackets used in the following Brake Kits, Right and Left are the same. Sold Each in Bulk  
 For Kit P/N: 22-2983, 22-2984 and 22-2985



## REPLACEMENT PARTS FOR EMPI BRAKE KITS

All bearing races must be **PRESSED** into rotors.

22-2841-B



22-2842-B



22-2843-7



22-2844-B



22-2961-B



22-2962-B



Part Number	Overall Diameter	Depth
22-2841-B	11"	4 1/8"
22-2842-B	11"	3 1/2"
22-2843-7	11"	3 1/2"
22-2844-B	11"	3 1/2"
22-2961-B	10 7/8"	3 15/16"
22-2962-B	10 7/8"	3 1/2"
22-2963-7	11"	3 1/4"
22-2964-B	11"	3 1/4"
22-2965-B	11"	3 1/4"
22-2972-B	11"	3 1/2"
22-2973-B	11"	3 1/2"
98-1153-B	11"	3 1/4"

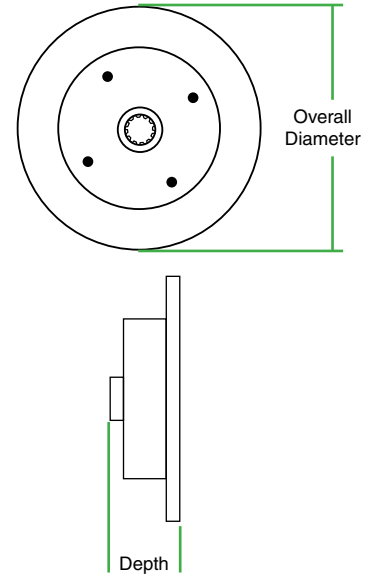

## REPLACEMENT BRAKE ROTORS

**22-2841-B** Replacement Rear Brake Rotor, 4/130, I.R.S., 68-on, Long Spline, Each  
(Ref. P/N: 113 615 601)

**22-2842-B** Repl. Rear Brake Rotor, 4/130, Swing Axle, thru 68, Short Spline, Each  
Can also be used for I.R.S. 68-on,  
requires P/N: 22-5281-7 spacer for I.R.S. Application  
(Ref. P/N: 113 615 601S)

**22-2843-7** Repl. Rear Brake Rotor, 5/130 Porsche & 5 / 4.75" Chevy Short Spline, Each  
Works for both Swing axle and I.R.S.  
(I.R.S. requires P/N: 22-5281-7 Spacer)  
Double drilled for use with either Porsche 5x130 bolt pattern using M14-1.5 threads or Chevy 5x4.75 bolt pattern using 12mm threads. Must purchase studs separately.

**22-2844-B** Replacement Rear Brake Rotor, Blank - No Holes, Short Spline, Each  
Works for both Swing axle and I.R.S.  
(I.R.S. requires P/N: 22-5281-7 Spacer)

**22-2961-B** Replacement Front Rotor for P/N 22-2880 Kit 5/205, to 65

**22-2962-B** Replacement Front Rotor for P/N 22-2885 Kit 5/205, 66-67, and P/N 22-2895 Kit 5/205, 68-on



# SUSPENSION & STEERING

## REPLACEMENT PARTS FOR EMPI BRAKE KITS

All bearing races must be **PRESSED** into rotors.

### REPLACEMENT BRAKE ROTORS

**22-2973-B** Replacement Rotor for 5/205 Rear Wide Track, Each  
Kits 22-2927, 22-2928, 22-2929, 22-2930, 22-2931, 22-2932  
I.R.S. requires 22-5281-7 Spacer  
Rotors are threaded for 12mm and 14mm studs



**22-2965-B** Replacement Rotor for Front 5/205, Each  
Kits 22-2925 and 22-2926



**22-2972-B** Replacement Rotor for Rear 5/205, I.R.S., Each  
Kits 22-2905, 22-2906, 22-2907  
I.R.S. requires 22-5281-7 Spacer



**98-1153-B** Replacement Front Rotor, 4/130, Ball Joint Front,  
All Type 1 66-79 w/ Disc Brakes, Ghia 66-74, Type 3 66-71, Each  
Kits 22-2850, 22-2855  
(Ref. P/N: 113 407 075)



**22-2963-7** Replacement Front Rotor, 5/130 Porsche and 5/4.75" Chevy,  
Ball Joint Front, All Type 1 66-79 w/ Disc Brakes, Ghia 66-74,  
Type 3 66-71, Each  
Kits 22-2981, 22-2982  
Double drilled for use with either Porsche 5x130 bolt pattern  
using M14-1.5 threads or Chevy 5/4.75" bolt pattern using  
12mm threads. Must purchase studs separately.



**22-2964-B** Replacement Front Rotor, Blank, No Holes, Ball Joint Front, Each  
Kits 22-2921, 22-2922

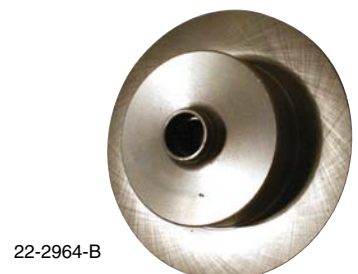

## **CROSS-DRILLED / LIGHTENED ROTORS**

**ALL BEARING RACES MUST BE PRESSED INTO ROTORS.**

**MUST USE PREMIUM QUALITY REPLACEMENT BRAKE PADS WITH ALL CROSS-DRILLED ROTORS.**



**22-3841-B** **NEW!** Replacement Rear Brake Rotor, 4/130, I.R.S., 68-on, Long Spline, Each



**22-3842-B** **NEW!** Repl. Rear Brake Rotor, 4/130, Swing Axle, thru 68, Short Spline, Each  
Can also be used for I.R.S. 68-on,  
requires P/N: 22-5281-7 spacer for I.R.S. Application



**22-3843-7** **NEW!** Repl. Rear Brake Rotor, 5/130 Porsche & 5 / 4.75" Chevy Short Spline, Each  
Works for both Swing axle and I.R.S.  
(I.R.S. requires P/N: 22-5281-7 Spacer)  
Double drilled for use with either Porsche 5x130 bolt pattern using M14-1.5 threads or Chevy 5x4.75 bolt pattern using 12mm threads. Must purchase studs separately.



**22-3861-B** **NEW!** Replacement Front Rotor for P/N 22-2880 Kit 5/205, to 65

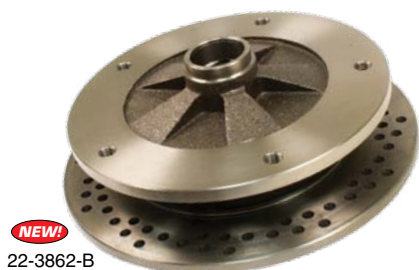

**22-3862-B** **NEW!** Replacement Front Rotor for P/N 22-2885 Kit 5/205, 66-67, and P/N 22-2895 Kit 5/205, 68-on



# SUSPENSION & STEERING

## CROSS-DRILLED / LIGHTENED ROTORS (CONT.)

**ALL BEARING RACES MUST BE PRESSED INTO ROTORS.**

**MUST USE PREMIUM QUALITY REPLACEMENT BRAKE PADS WITH ALL CROSS-DRILLED ROTORS.**

- 22-3873-B** **NEW!** Replacement Rotor for 5/205 Rear Wide Track, Each  
Kits 22-2927, 22-2928, 22-2929, 22-2930, 22-2931, 22-2932  
I.R.S. requires 22-5281-7 Spacer  
Rotors are threaded for 12mm and 14mm studs



**NEW!**  
22-3873-B

- 22-3865-B** **NEW!** Replacement Rotor for Front 5/205, Each  
Kits 22-2925 and 22-2926



**NEW!**  
22-3865-B

- 22-3872-B** **NEW!** Replacement Rotor for Rear 5/205, I.R.S., Each  
Kits 22-2905, 22-2906, 22-2907  
I.R.S. requires 22-5281-7 Spacer



**NEW!**  
22-3872-B

- 22-3853-B** **NEW!** Replacement Front Rotor, 4/130, Ball Joint Front,  
All Type 1 66-79 w/ Disc Brakes, Ghia 66-74, Type 3 66-71, Each  
Kits 22-2850, 22-2855



**NEW!**  
22-3853-B

- 22-3863-7** **NEW!** Replacement Front Rotor, 5/130 Porsche and 5/4.75" Chevy,  
Ball Joint Front, All Type 1 66-79 w/ Disc Brakes, Ghia 66-74,  
Type 3 66-71, Each  
Kits 22-2981, 22-2982  
Double drilled for use with either Porsche 5x130 bolt pattern  
using M14-1.5 threads or Chevy 5/4.75" bolt pattern using  
12mm threads. Must purchase studs separately.



**NEW!**  
22-3863-7

## PREMIUM REPLACEMENT BRAKE PADS

Superior friction materials for maximum stopping power, less dust and long-lasting quiet operation...a Premium upgrade for your Disc Brake Calipers and Rotors.

- 22-2992** Premium Brake Pads, Set of 4, For P/N: 98-1150-B Caliper
- 22-2993** Premium Brake Pads, Set of 4,  
For P/N: 22-6123-B & 22-6124-B Calipers
- 22-2994** Premium Brake Pads, Set of 4  
For P/N: 22-6125-B & 22-6126-B Calipers
- 22-2995** Premium Brake Pads, Set of 4  
For P/N: 22-2956-B & 22-2957-B Calipers

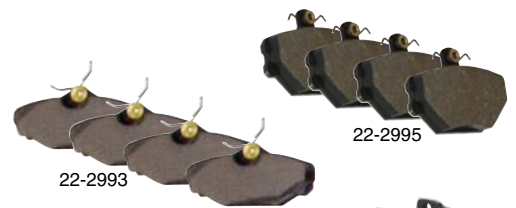

22-2993

22-2995



22-2994



22-2992



## REPLACEMENT PARTS FOR EMPI BRAKE KITS

### REPLACEMENT BRAKE CALIPERS

**98-1150-B** Replacement Brake Caliper, Each (Boxed)  
 (Ref. P/N: 311 615 107/8) Right & Left use the same Calipers, **Supplied w/Pads**  
 For Kit P/N: 22-2850, 22-2855, 22-2861, 22-2861-F, 22-2862, 22-2862-F, 22-2881, 22-2882, 22-2886, 22-2887, 22-2910, 22-2910-F, 22-2911, 22-2911-F, 22-2916, 22-2916-F, 22-2917, 22-2917-F, 22-2921, 22-2922, 22-2923, 22-2924, 22-2929, 22-2929-F, 22-2930, 22-2930-F, 22-2981, 22-2982, 22-2983, 22-2984, 22-2985, 22-2986, 22-2990, 22-2991

**22-2890** Replacement Brake Pads, Set of 4  
 For P/N: 98-1150-B Caliper, 311-615-107/8

**22-6124-B** Repl. Right Rear Caliper, Side Inlet, Supplied w/o Pads, Each (Boxed)  
 For P/N: 22-2865, 22-2865-F, 22-2870, 22-2870-F, 22-2871, 22-2871-F, 22-2905, 22-2905-F, 22-2906, 22-2906-F, 22-2907, 22-2907-F, 22-2912, 22-2912-F, 22-2913, 22-2913-F, 22-2914, 22-2914-F, 22-2918, 22-2918-F, 22-2919, 22-2919-F, 22-2920, 22-2920-F, 22-2927, 22-2927-F, 22-2928, 22-2928-F

**22-6123-B** Repl. Left Rear Caliper, Side Inlet, Supplied w/o Pads, Each (Boxed)  
 For P/N: 22-2865, 22-2865-F, 22-2870, 22-2870-F, 22-2871, 22-2871-F, 22-2905, 22-2905-F, 22-2906, 22-2906-F, 22-2907, 22-2907-F, 22-2912, 22-2912-F, 22-2913, 22-2913-F, 22-2914, 22-2914-F, 22-2918, 22-2918-F, 22-2919, 22-2919-F, 22-2920, 22-2920-F, 22-2927, 22-2927-F, 22-2928, 22-2928-F

**22-2865-1** Brake Line Adapter for P/N 22-6123-B & P/N 22-6124-B Calipers, **For older production of these calipers** (Ea)  
 Female I.D. = 10m x 1.00 / Male O.D. = 10m x 1.50

**22-2891** Replacement Brake Pads, Set of 4  
 For P/N: 22-6123-B, 22-6124-B Calipers

**22-6125-B** Repl. Left Front Caliper, Supplied w/o Pads, Each (Boxed)  
 For P/N: 22-2880, 22-2885, 22-2895

**22-6126-B** Repl. Right Front Caliper, Supplied w/o Pads, Each (Boxed)  
 For P/N: 22-2880, 22-2885, 22-2895

**22-2892** Replacement Brake Pads, Set of 4  
 For P/N: 22-6125-B, 22-6126-B Calipers

**22-2959-B** Repl. Left Rear EMPI Caliper, Top Inlet, w/ E-Brake, Supplied w/o Pads, Each (Boxed). **This Caliper is no longer used in EMPI kits. Years ago it was used in the following kits:**  
 For P/N: 22-2865, 22-2870, 22-2871, 22-2905, 22-2906, 22-2907, 22-2912, 22-2913, 22-2914, 22-2918, 22-2919, 22-2920, 22-2927, 22-2928

**NOTE: When installing calipers, inlet port faces up, E-brake spring faces down. This caliper has the part number and EMPI in the casting.**

**22-2960-B** Repl. Right Rear EMPI Caliper, Top Inlet, w/ E-Brake, Supplied w/o Pads, Each (Boxed). **This Caliper is no longer used in EMPI kits. Years ago it was used in the following kits:**  
 P/N: 22-2865, 22-2870, 22-2871, 22-2905, 22-2906, 22-2907, 22-2912, 22-2913, 22-2914, 22-2918, 22-2919, 22-2920, 22-2927, 22-2928

**NOTE: When installing calipers, inlet port faces up, E-brake spring faces down. This caliper has the part number and EMPI in the casting.**

**22-2966** Replacement Brake Pads, Set of 4  
 For P/N: 22-2959-B, 22-2960-B EMPI Calipers

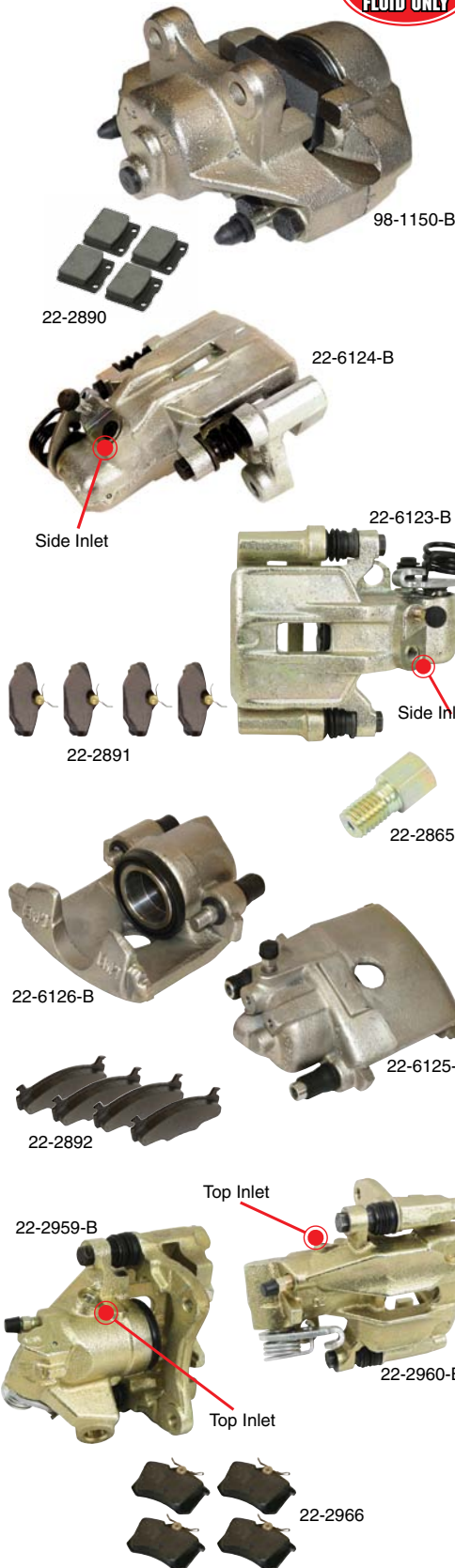





# SUSPENSION & STEERING

## REPLACEMENT PARTS FOR EMPI BRAKE KITS



### REPLACEMENT BRAKE CALIPERS

- 22-2956-B** Repl. Front Caliper, Supplied w/o Pads, Each (Boxed)  
NOTE: Left Side for P/N 22-2926 Kit, Right Side for P/N 22-2925 Kit
- 22-2957-B** Repl. Front Caliper, Supplied w/o Pads, Each (Boxed)  
NOTE: Left Side for P/N 22-2925 Kit, Right Side for P/N 22-2926 Kit
- 22-2958** Replacement Brake Pads, Set of 4  
For P/N: 22-2956-B, 22-2957-B Calipers

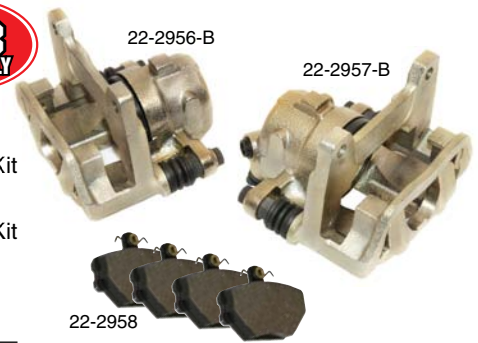

### PREMIUM REPLACEMENT BRAKE PADS

Superior friction materials for maximum stopping power, less dust and long-lasting quiet operation...a Premium upgrade for your Disc Brake Calipers.

- 22-2992** Premium Brake Pads, Set of 4, For P/N: 98-1150-B Caliper
- 22-2993** Premium Brake Pads, Set of 4,  
For P/N: 22-6123-B & 22-6124-B Calipers
- 22-2994** Premium Brake Pads, Set of 4  
For P/N: 22-6125-B & 22-6126-B Calipers
- 22-2995** Premium Brake Pads, Set of 4  
For P/N: 22-2956-B & 22-2957-B Calipers

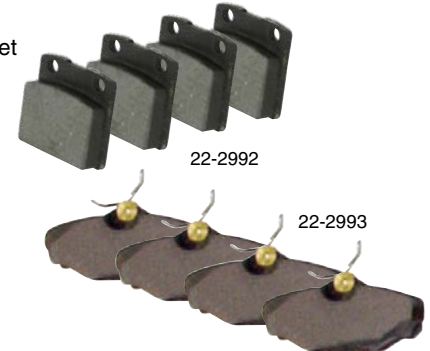

### REPLACEMENT BRAKE PADS (Supplied in Kits)

- 22-2890** Replacement Brake Pads, Set of 4  
For P/N: 98-1150-B Caliper, 311-615-107/8
- 22-2891** Replacement Brake Pads, Set of 4  
For P/N: 22-6123-B, 22-6124-B Calipers
- 22-2892** Replacement Brake Pads, Set of 4  
For P/N: 22-6125-B, 22-6126-B Calipers
- 22-2966** Replacement Brake Pads, Set of 4  
For P/N: 22-2959-B, 22-2960-B Calipers
- 22-2958** Replacement Brake Pads, Set of 4  
For P/N: 22-2956-B, 22-2957-B Calipers

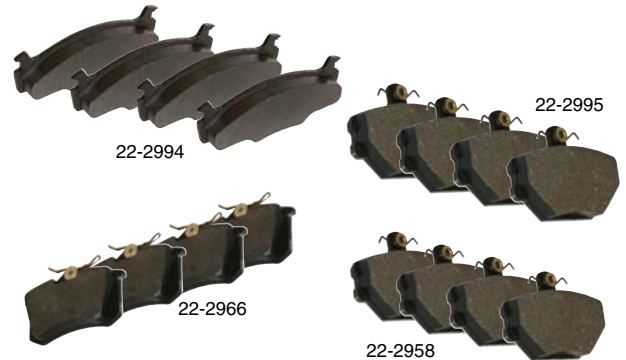

### REPLACEMENT SPACER

- 22-5281-7** Replacement Spacer for I.R.S. Rotor, Each  
Converts Swing Axle Rotor numbers to fit I.R.S.  
With adding this spacer, a 22-2842-B, 22-2843-7, and  
22-2844-B will also fit 22-2841-B applications  
(Ref. P/N: 111 501 303B)
- 22-2865-1** Brake Line Adapter for 22-6123-B & 22-6124-B Calipers, (Ea)  
**For older production of these calipers**

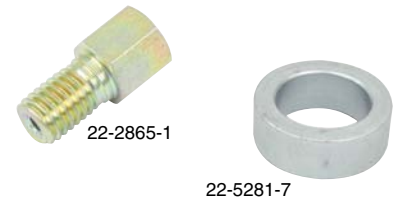

### REPLACEMENT BRAKE CABLES

- 22-6096** Emergency Brake Cable, Each (Bulk), 68" overall length  
For Kit P/N: 22-2865, 22-2871, 22-2905,  
22-2907, 22-2912, 22-2914, 22-2918, 22-2920
- 22-6099** Emergency Brake Cable, Each (Bulk), 72" overall length  
For Kit P/N: 22-2870, 22-2906, 22-2913, 22-2919

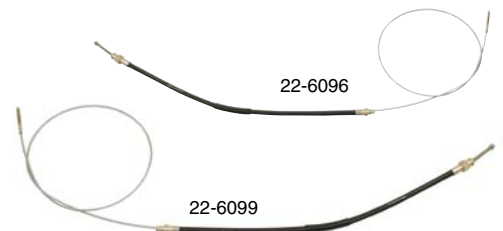

## BRAKE DRUM & ROTORS

Make EMPI your one stop shop for quality replacement brake drums and rotors. A wide selection that covers most popular applications.



### TYPE 1 & SUPER BEETLE

- |              |           |   |
|--------------|-----------|---|
| 113 405 615A | 98-4002-B | Front Brake Drum, Type 1 58-65, Ghia 58-65                                  |
| 131 405 615A | 98-4600-B | Front Brake Drum, Type 1 66-67  |
| 111 405 615B | 98-4001-B | Front Brake Drum, Type 1 68-77 (Exc. Super Beetle)                          |
| 113 405 615H | 98-4601-B | Front Brake Drum, Type 1 71-79, Super Beetle                                |
| 113 407 075  | 98-1153-B | Front Brake Rotor, All Type 1 66-79 w/Disc Brakes, Ghia 66-74, Type 3 66-71 |
| 113 501 615D | 98-5001-B | Rear Brake Drum, Type 1 58-67, Ghia 58-65                                   |
| 113 501 615J | 98-5002-B | Rear Brake Drum, Type 1 68-79, Ghia 68-74                                   |
| 98-5002-7    |           | Rear Brake Drum – Porsche & Chevy P.C.D., Type 1 68-79, Ghia 68-74          |

Double drilled for use with either Porsche 5x130 bolt pattern using M14-1.5 threads or Chevy 5x4.75 bolt pattern using 12mm threads. Must purchase studs separately. [See page 283-285 for all studs.](#)

### TYPE 2

- |                             |                       |   |
|-----------------------------|-----------------------|---|
| 211 405 615C / 211 405 615B | <b>NEW!</b> 98-4602-B | Front Brake Drum, Type 2 64-70<br>For 64-67 Type 2 Applications, use Seal P/N: 211 405 641B |
| 211 501 615E                | 98-5003-B             | Rear Brake Drum, Type 2 64-67   |
| 211 501 615G                | 98-5005-B             | Rear Brake Drum, Type 2 68-70   |

### TYPE 3

- |              |           |                               |
|--------------|-----------|-------------------------------|
| 311 501 615F | 98-5008-B | Rear Brake Drum, Type 3 66-On |
| 311 501 615E | 98-5007-B | Rear Brake Drum, Type 3 63-65 |

### THING

- |              |                       |                                   |
|--------------|-----------------------|-----------------------------------|
| 181 501 615A | <b>NEW!</b> 98-5019-B | Rear Brake Drum, Thing, All Years |
|--------------|-----------------------|-----------------------------------|



# SUSPENSION & STEERING

## WHEEL BEARINGS AND SEALS

102 405 593	22-2849-B	Front Disc Brake Backing Plate, Each
111 405 627	98-4626-B	Front Inner Wheel Bearing, Type 1, thru 65, Each
311 405 625	98-4622-B	Front Inner Wheel Bearing, Type 1 & 3, 66-68, Each
311 405 625B	98-1154-B	Front Inner Wheel Bearing, Type 1 & 3, 69-on, Each
211 405 625	98-4620-B	Front Inner Wheel Bearing, Type 2, 64-79, Each
111 405 647	98-4625-B	Front Outer Wheel Bearing, Type 1, thru 65, Each
311 405 645	98-1155-B	Front Outer Wheel Bearing, Type 1 & 3, 66-on, Each
211 405 645D	98-4623-B	Front Outer Wheel Bearing, Type 2, 64-79, Each
111 405 641A	98-4618-B	Front Wheel Seal, Type 1, thru 65, Each
131 405 641A	98-4627-B	Front Wheel Seal, Type 1, 66-6/68, Each
111 405 641B	98-4621-B	Front Wheel Seal, Type 1, 69-on w/Drum Brakes, Each
321 501 641	98-1156-B	Front Wheel Seal, Type 1 & 3, 66-79 w/Disc Brakes, Each
211 405 641A	98-4617-B	Front Wheel Seal, Type 2, thru 63, Each
211 405 641B	98-4624-B	Front Wheel Seal, Type 2, 64-67, Each
311 501 283	98-5016-B	Ball Bearing, Swing Axle, Rear Axle, Type 1, thru 68
113 501 277A	98-5014-B	Roller Bearing, Rear Axle, Outer, Type 1, 68-79
113 501 283	98-5015-B	Ball Bearing, Rear Axle, Inner, Type 1, 68-79
113 501 315H	98-5021-B	Oil Seal, Rear Axle, Type 1, All
311 598 051B	9910-B	Rear Axle Seal Kit, Type 1, All (Ref P/N: 311 598 051B)
111 405 631B	98-4046-B	Link Pin Bearing Spacer, Type 1, thru 65, Each <i>Axle Spacer for Link Pin Spindles</i>



## KING PIN CONVERSION BEARINGS

Allows you to install ball joint rotors onto King Pin spindles.  
Requires new seals, P/N 98-1156-B.

17-2795	King Pin Conversion Bearing, Inner, Each O.D. = 1.977", I.D. = .9845"
17-2796	King Pin Conversion Bearing, Outer, Each O.D. = 1.570", I.D. = .7875"



## SPINDLE CLAMP NUTS

Use our OEM-style Spindle Clamp Nuts to properly secure your rotor/drum.

98-4049-B	Spindle Clamp Nut w/ screw, 16mmx1.5 Left, Type 1 66 & Later, Type 3 64 & Later, Each
(Ref P/N: 131 405 669)	
98-4050-B	Spindle Clamp Nut w/ screw, 16mmx1.5 Right, Type 1 66 & Later, Type 3 64 & Later, Each
(Ref P/N: 131 405 670)	
22-2986-1	Spindle Clamp Nut w/ screw, 18mmx1.5 Left, Type 1 50-65, Each
22-2986-2	Spindle Clamp Nut w/ screw, 18mmx1.5 Right, Type 1 50-65, Each





**Race Trim**

## RACE-TRIM MICRO STUB BRAKE KITS

State of the art suspension is just one step away! Micro-stub brake systems are necessary if you are going to use a rear suspension that is different from a VW style trailing arm arrangement. This Race-Trim kit utilizes the best of the best in both components and materials used. 4-piston brake calipers, vented rotors, forged chromoly stub axles, forged hub assemblies, 6061 T-6 aluminum alloy rotor hats & wheel adapters. This combination gives you the winning edge, whether it's for racing or just an all out turbo long-travel sand car! Kits come complete ready for fab-in installation and are sold as a set. In addition we also offer a Micro-Arm flange tube to facilitate installation of the Race-Trim Micro Stub brake kit to a tubular trailing arm. Bolt pattern is 5 on 205.

- 16-2510 Race-Trim Micro Stub Brake Kit, for 930 C.V. Joints
- 16-2511 Race-Trim Micro Stub Brake Kit, for 934 C.V. Joints
- 16-2516 Mount Tube Only for Race-Trim Micro Stub Kit, Pair (Not included in brake kits)

### EXPLODED VIEW

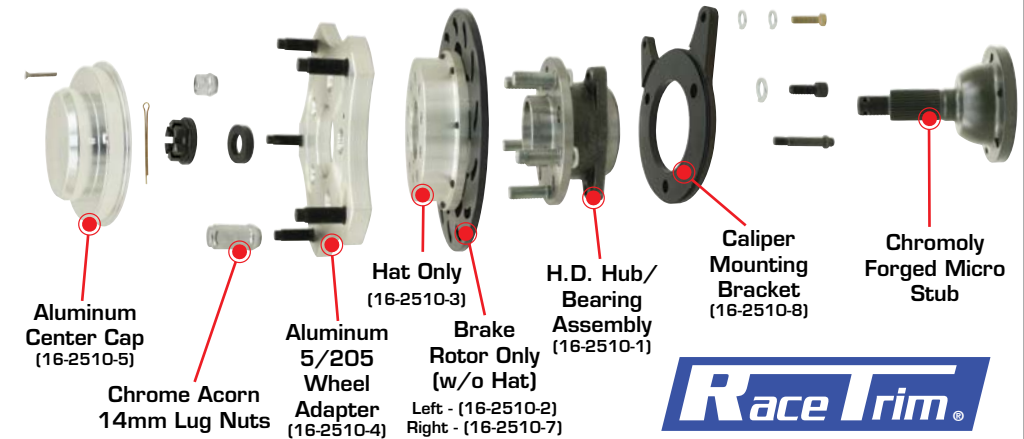

**Race Trim**

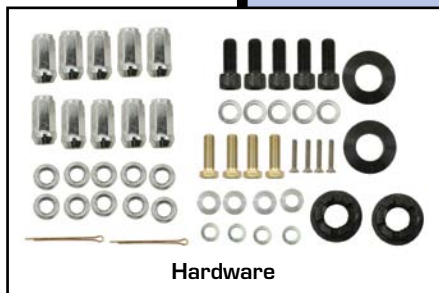

- (2) Micro-Stubs
- (2) Center Caps
- (2) Hub/Bearing Assemblies
- (2) Brake Rotor/Hat Assemblies
- (2) Wheel Adapters 5/205
- (2) Caliper Mounting Brackets
- (2) Brake Calipers (Pads Seperate)
- (2) Axle Nuts M24x1.5
- (4) 3/8-24 x 2 Bolts
- (4) 3/8 Flat Washers
- (4) 3/8 Lock Washers
- (10) Chrome 14mm Lug Nuts
- (10) 14mm Open End Lug Nuts
- (6) 12mm Socket Screws
- (6) 12mm Lock Washers
- (2) Cotter Pins
- (4) 10-24 Socket Screws
- (2) Thrust Washers
- (4) Brake Pads
- (12) C.V. Bolts

## FORGED 1 PIECE CHROMOLY MICRO-STUB AXLES

Leading manufacturers of high performance, off-road and drag racing drivetrains will tell you that a forged 4340 chromoly part is better and stronger than 300m from billet. Our 930 and 934 micro stub axles are 1.490" diameter, 33 spline (equivalent to a 2500 G.M. truck). We use 4340 chromoly forgings which are then 100% CNC machined. The splines are cold formed/rolled rather than cut and extend the entire length of the shaft, opposed to being "back cut". The inner portion of flange has a very deep radius. Hardened axle nut washers are included. Both parts are black oxidized.

- 16-2310 Microstub Axle w/ washer for 930 C.V. Joint, Each
- 16-2311 Microstub Axle w/ washer for 934 C.V. Joint, Each



**For more information on this micro stub brake kit, please refer to the next page.**



# SUSPENSION & STEERING



16-2510-1

## HUB / BEARING ASSEMBLY

The Race-Trim hub / bearing assembly features a 33 spline 1.490" center section with sealed, heavy duty bearing and 14mm pressed in grade 10.9 studs (equivalent to a 2500 G.M. truck). The bolt pattern is 5 on 4.750". The bearing is not replaceable.

16-2510-1 Replacement Hub Bearing Assembly, Each



16-2510-8

## MOUNTING BRACKETS

The black oxidized caliper mounting brackets are supplied with the kit. These brackets are .390" thick with a machined groove to properly register the optional chassis mounting tubes.

16-2510-8 Replacement Bracket, Each

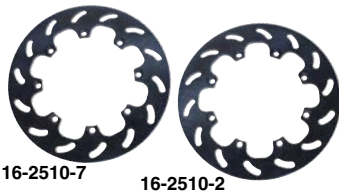

16-2510-7

16-2510-2

## 11 1/4" VENTED BRAKE ROTOR

The .360" thick, 11.250" diameter rotor which is blanchard ground and black oxidized, is bolted to a .460" thick aluminum hub assembly with 5/16" grade 8 bolts. The hub is machined with a receiver groove to mate with the wheel adapter. Rotor only, is sold separately w/o the hat.

16-2510-2 Replacement Left Rotor Only, Each

16-2510-7 Replacement Right Rotor Only, Each



16-2510-4

## ALUM. 6061-T6 WHEEL ADAPTER

The .650" thick wheel adapter allows you to utilize the 5/205 bolt pattern wheels that are available in the market today. It is machined to integrate into the rotor and hub/bearing assemblies to create a solid braking unit. The 14mm studs are pressed in.

16-2510-4 Replacement Wheel Adapter, Each



16-2525-7

## WILWOOD HIGH PERFORMANCE FORGED CALIPERS

We include Wilwood forged calipers, long recognized as a leader in competition disc brakes. Calipers feature 4 Stainless Steel Pistons. Poly Matrix Competition Pads sold separately.

16-2525-7 Replacement Caliper, w/o Pads, Each

16-2525-6 Replacement Pads, Two Pair



16-2525-6



16-2510-5

## WHEEL ADAPTER CENTER CAP

A satin finish aluminum center cap is attached to the center of the wheel adapter by two 10-24 stainless steel counter sunk allen screws. The Race-Trim logo is engraved in the center giving the kit that finished looked.

16-2510-5 Replacement Cap, Each



16-2413 (930 C.V.)

16-2414 (934 C.V.)

## 930 AND 934 C.V. BOLTS

Both micro stubs are supplied with the necessary C.V. bolts.

16-2413 Repl. 3/8" x 24, 12 point, grade 8 (930), 6 pcs.

16-2414 Repl. 7/16" x 20, 12 point shouldered, grade 10.9 (934), 6 pcs.



16-2516  
Not Included  
in Kits

## HARDWARE / CHASSIS MOUNT TUBE

The optional 6.500" diameter mount tubes are the popular choice of fabricators and chassis builders. They are a thick wall, angle cut piece that registers into the pre-cut groove on the caliper bracket providing a gap free fit for welding. This allows you to weld on the appropriate tabs and brackets.

16-2516 Mounting Tubes Only, Pair

# SUSPENSION & STEERING



**WARNING:** It is extremely important that brake lines be installed by a trained mechanic. Proper length of each line in relation to wheel travel and steering angle is critical to avoid brake failure. Equally important is brake lines must be free flowing and have no contamination. Additionally, all calipers must be bled properly, regardless of kit purchased. Do not attempt brake line or caliper installation without the experience to properly evaluate all of these issues.

## BRAKE LINE RESIDUAL PRESSURE VALVES

Maintains minimum constant line pressure to help eliminate excessive pedal travel and create a much firmer and responsive pedal feel. The two pound valve is recommended for disc brake applications while the 10 pound valve is mostly used on drum brake applications. EMPI's residual pressure valves are made from billet aluminum and are color coded and marked for easy identification and in-line mount using standard SAE brake line fittings.



- 16-3155** 2 PSI Residual Pressure Valve, SAE
- 16-3156** 10 PSI Residual Pressure Valve, SAE

- 17-2928** 2 PSI METRIC Residual Pressure Valve (Aluminum)  
Easy Installation with 10mm x 1.0 Female Metric Threads on each end.
- 17-2932** 2 PSI SAE Residual Pressure Valve (Aluminum), 1/8" NPT Both Ends  
Easy Installation with 1/8" NPT Male / 1/8" NPT Female Threads.

## BRAKE LINE RESIDUAL PRESSURE VALVE KIT

Our 2PSI Residual Valve for Disc Brake applications with Metric female threads on both ends packaged with a 7.5" brake line makes installation a true Plug 'n Play. This kit utilizes our P/N 17-2928 valve.

- 17-2935** 2 PSI Residual Pressure Valve with a 7.5" brake line, Kit

## BRAKE PROPORTIONING VALVE

This EMPI Knob-style Proportioning Valve enables you to adjust front to rear brake bias with a twist of a knob. Provides up to a 50% reduction. Fitting ports are 1/8" NPT. Valve includes two fittings to adapt to 3/16" SAE brake line. Allows easy adjustment of front to rear brake bias.

- 16-3157** Brake Proportioning Valve

## EMPI HYDRAULIC PARK LOCK

This hydraulic Park Lock uses line pressure to hold your brakes locked. Just push brake pedal down and push the Park Lock lever. (Not to be used as an emergency brake).

- 3155** EMPI Hydraulic Park Lock

## BRAIDED STAINLESS STEEL BRAKE LINE KITS

EMPI's Stainless Steel Brake Lines are made of super tough braided stainless steel covers over Poly hose, and are **D.O.T. approved** - which is important in such a critical part as a brake hose. Because they are made with the stock size fittings, no adapters are needed to insure a correct fit, and it lessens the chance of leakage. Stainless Steel Brake Line Kits must be installed at all four corners, never mix rubber and stainless in the same brake system. Caution should be used when installing any new brake line. If you have any doubt about your ability to install them correctly, please let a trained professional mechanic do the job. **Made in USA.**



**D.O.T. Approved!**

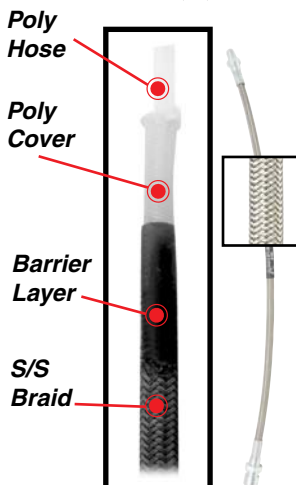

- 5585** 4-Piece Braided **Stainless** Brake Line Kit, Type 1, 58-64
- 5586** 4-Piece Braided **Stainless** Brake Line Kit, Type 1, 65-68
- 5587** 4-Piece Braided **Stainless** Brake Line Kit, Type 1, 69-on w/I.R.S.
- 5588** 4-Piece Braided **Stainless** Brake Line Kit, Super Beetle, 71-73
- 5589** 4-Piece Braided **Stainless** Brake Line Kit, Super Beetle, 73 1/2-on

- 98-6713-B** Braided **S/S** Brake Line, Front, M/F, 480mm (18.90"), Type 1 thru 64, Type 2 thru 54, Each
- 98-6711-B** Braided **S/S** Brake Line, Front, M/F, 380mm (15"), Type 1, 67 & Later (Exc. S/B), Each
- 98-6715-B** Braided **S/S** Brake Line, Front, M/F, 440mm (17.32"), Type 1, 65-66, Type 2, 55-67, Each
- 98-6714-B** Braided **S/S** Brake Line, Rear, M/F, 240mm (9.45"), Type 1, 68 & Later IRS, Each
- 98-6716-B** Braided **S/S** Brake Line, Rear, F/F, 270mm (10.63"), All Type 1, 2, 3 w/ Swing Axle, Each
- 98-6717-B** Braided **S/S** Brake Line, Rear, F/F, 340.5mm (13.39"), S/B, 74 & Later, Each

**D.O.T. Approved!**

**3 Layer Construction!**



# SUSPENSION & STEERING

**WARNING:** It is extremely important that brake lines be installed by a trained mechanic. Proper length of each line in relation to wheel travel and steering angle is critical to avoid brake failure. Equally important is brake lines must be free flowing and have no contamination. Additionally, all calipers must be bled properly, regardless of kit purchased. Do not attempt brake line or caliper installation without the experience to properly evaluate all of these issues.

## DUAL CIRCUIT MASTER CYLINDERS

If you are installing disc brakes to all four wheels, the use of this master cylinder is mandatory. The stock master cylinder cannot supply the additional pressure or the correct bias needed in a 4-wheel disc brake application. The answer is our 20.6mm bore Dual Circuit Master Cylinder. We offer one unit for all standard Beetles and another for Super Beetles only. **Recommended for all 4-Wheel Disc Brake applications.**



### EMPI Brand

<b>113 611 015BDD</b>	<b>16-9554</b>	20.6mm Dual Circuit Master Cylinder ( <b>All Beetles</b> ), Ea
<b>133 611 015HDD</b>	<b>17-2808</b>	20.6mm Dual Circuit Master Cylinder ( <b>Super Beetle Only</b> ), Ea



16-9554



17-2808

## MASTER CYLINDERS

Don't take a chance on an old and leaking Master Cylinder. Replace it with a brand new one.

### EMPI Brand

<b>113 611 021CCH</b>	<b>98-6204-B</b>	Master Cylinder, Type 1, thru 64
<b>113 611 023BCH</b>	<b>98-6206-B</b>	Master Cylinder, Type 1, 65-66
<b>113 611 015BDCH</b>	<b>98-6019-B*</b>	Master Cylinder, Type 1, 67-on (Exc. S/B)



\*Recommended for replacement for 67 & later and on all Front Wheel Disc Brake/Rear Wheel Drum Brake applications.



113 611 021CCH



113 611 023BCH

<b>113 611 015BHCH</b>	<b>98-6203-B</b>	Master Cylinder, Super Beetle, 71-79
<b>211 611 011JCH</b>	<b>98-6021-B</b>	Master Cylinder, Type 2, thru 66 (22mm w/ Residual Valve)
	<b>98-6022-B*</b>	22mm Buggy Master Cylinder w/o Residual Valve. For use with Disc Brakes. (Does not include reservoir)

\*Residual Valve Removed - for all Front Wheel Disc Brake / Rear Wheel Drum Brake applications or Rear Disc Only applications (Trike)



113 611 015BDCH



98-6022-B

<b>211 611 021AACH</b>	<b>98-6205-B</b>	Master Cylinder, Type 2, 68-79
------------------------	------------------	--------------------------------

### VARGA Brand

<b>113 611 021C</b>	<b>98-6004-B</b>	Master Cylinder, Type 1, thru 64 (Varga)
<b>113 611 023B</b>	<b>98-6006-B</b>	Master Cylinder, Type 1, 65-66 (Varga)
<b>113 611 015BD</b>	<b>98-6002-B</b>	Master Cylinder, Type 1, 67-on (Exc. S/B) (Varga)
<b>113 611 015BH</b>	<b>98-6003-B</b>	Master Cylinder, Super Beetle, 71-79 (Varga)
<b>211 611 011J</b>	<b>98-6001-B</b>	Master Cylinder, Type 2, thru 66 (Varga)
<b>211 611 021AA</b>	<b>98-6005-B</b>	Master Cylinder, Type 2, 68-79 (Varga)



113 611 015BD



211 611 011J

99% of the calls we received concerning problems with brake installation comes down to 1 problem...**AIR IN THE LINES**. No one wants to hear it, after having bled the system 2 or 3 times...but spongy pedal, pads dragging, etc., almost always is the cause of air trapped in the system.

Be sure to Bench Bleed a new master cylinder if installed. There are a few different '1-Man Bleeders' available - Mityvac and others. Use our new Quick Bleeders...make it easy on yourself and your helpers.

If installing new Disc Brake Calipers, rotate them to where the bleeder is around 12 O'Clock for bleeding...easier to get the air going straight up...then rotate them into position when you are done.

When all else fails, take the car to a professional for bleeding and adjusting. Small price to pay if you do not have the patience!



## BUGGY MASTER CYLINDER

The large 22mm bore Master Cylinder is large enough to handle 2 or 4 wheel set-ups. Available complete with reservoir or replacement reservoir only.

**6112** 22mm Buggy Master Cylinder, w/Residual Valve and Reservoir  
**98-6020-B** Plastic Reservoir Only  
 (Ref. P/N: 211 611 301C)



**98-6021-B** 22mm Buggy Master Cylinder Only w/Residual Valve  
 (Ref. P/N: 211 611 011JCH)

**98-6022-B** 22mm Buggy Master Cylinder Only w/o Residual Valve.  
 For use with Disc Brakes. (Does not include reservoir)



## BUGGY MASTER CYL. W/POLISHED ALUM. RESERVOIR

Every year it's the first thing on your shopping list...New brake reservoir to replace the sun baked or leaking one from last season. EMPI puts an end to the vicious cycle with this polished Billet Aluminum Reservoir, it's the best looking and last one you will need.

**6114** 22mm Buggy Master Cylinder w/Residual Valve and Polished Aluminum Reservoir

**16-7040** Polished Billet Aluminum Master Cylinder Reservoir Only w/Cap

**98-6021-B** 22mm Buggy Master Cylinder Only w/Residual Valve  
 (Ref. P/N: 211 611 011JCH)



## POLISHED/CHROME BUGGY MASTER CYLINDER

Large 22mm bore, Polished/Chrome Master Cylinder for 2 or 4 wheel brake applications while adding a show-look to your buggy. Chose a Billet or Plastic reservoir.

**16-7041** **NEW!** 22mm Polished/Chrome Buggy Master Cylinder, w/Residual Valve

**16-7042** **NEW!** 22mm Polished/Chrome Buggy Master Cylinder, w/o Residual Valve



## BUGGY MASTER CYLINDER WITH BILLET ALUMINUM RESERVOIR

Complete Type 2 Master Cylinder with the great looking Billet Aluminum Buggy Master Cylinder Reservoir to add that billet flare to your Buggy. Billet Aluminum Buggy Master Cylinder Reservoir fits Type 2 (thru 66) master cylinders (EMPI P/N 16-7041, 16-7042 and 98-6021-B/211 611 011JCH).

**6116** **NEW!** Buggy Master Cylinder with Billet Aluminum Reservoir, Set

**18-1015** **NEW!** Aluminum Buggy Master Cylinder Reservoir, Each







# SUSPENSION & STEERING

## STOCK MASTER CYLINDER RESERVOIRS

113 611 301G	98-6671-B	Reservoir, Brake Fluid, Incl. Cap, Type 1 61-66, Ghia 61-66
113 611 301L	98-6672-B	Reservoir, Brake Fluid, w/Cap, Type 1 68-79, Type 3 66-73
113 611 817	98-6683-B	Grommet, Master Cylinder, Type 1 50-66, Each
211 611 817A	98-6684-B	Grommet, Master Cylinder, Type 1 67-79, Type 2 67-79, Ea



## DUAL CIRCUIT RESERVOIR

Eliminates fittings and installs directly to your '67 & later dual-circuit master cylinder. No hoses or fittings required - perfect mounting solution for buggies. Also fits EMPI P/N 16-9554 & 17-2808.

17-2878	Dual Circuit Master Cylinder Reservoir, Type 1 67 & Later
---------	---

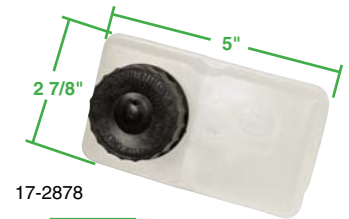

## BRAKE LIGHT SWITCHES

Brake light switches deteriorate with age causing them to malfunction. If your brake lights don't come on with a small amount of pressure applied to the brake pedal, it's time to replace your switch. We recommend always using a new switch when installing a new master cylinder.

98-2057	Brake Light Switch, 3 Prong (Bulk P/N: 113 945 515G)
98-2058	Brake Light Switch, 2 Prong (Bulk P/N: 113 945 515H)



## QUICK BLEEDERS

For EMPI Disc Brake Kits...the patented Quick Bleeder is a one-person brake bleeder screw that speeds up the job of purging old fluid and air from your newly installed Brake Calipers. The Quick Bleeder has a unique check ball design which allows old fluid and air to be pushed out but closes between pumps, preventing the old fluid and air from re-entering the system.

22-5287	7mm x 1.0 Bleeder Screws, Pr., Fits P/N 98-1150-B Calipers
22-5288	8mm x 1.0 Bleeder Screws, Pr., Fits P/N 22-2956-B, 22-2957-B, 22-6123-B & 22-6124-B Calipers
22-5290	10mm x 1.0 Bleeder Screws, Pr., Fits P/N 22-6125-B, 22-6126-B, 22-2959-B & 22-2960-B Calipers





## BRAKE HOSES

Don't overlook the brake hoses when doing brake system work, even when hoses appear good from the outside, aging hoses can swell shut on the inside causing restricted flow resulting in pulling or binding of the brakes.

113 611 701	98-6700-B	Brake Hose, M/F 480mm, Front, Type 1, thru 64, Type 2, thru 54
113 611 701D	98-6701-B	Brake Hose, M/F 380mm, Front, Type 1, 67-on (Exc. Super Beetle)
113 611 701E	98-6702-B	Brake Hose, F/F 355mm, Front, Super Beetle, 74-on Type 2, 71-79
211 611 701	98-6703-B	Brake Hose, M/F 440mm, Front, Type 1, 65-66, Type 2, 55-67
311 611 701B	98-6704-B	Brake Hose, Front, M/F 355mm, Type 1 & 3, 66-on w/Disc Brakes
113 611 775E	98-6705-B	Brake Hose M/F 240mm, Rear, Type 1, 68-on (I.R.S.)
211 611 775B	98-6706-B	Brake Hose, Rear, F/F 270mm, Type 1/2/3, w/Swing Axle, S/B 71-73 Front Type 2, Right Rear 68-79
	<b>NEW!</b> 98-6707-B	Brake Hose M/F 110mm, Universal Applications
	<b>NEW!</b> 98-6708-B	Brake Hose M/F 610mm, Universal Applications
211 611 775C	<b>NEW!</b> 98-6709-B	Brake Hose M/F 292mm, Type 2, Left Rear 68-79

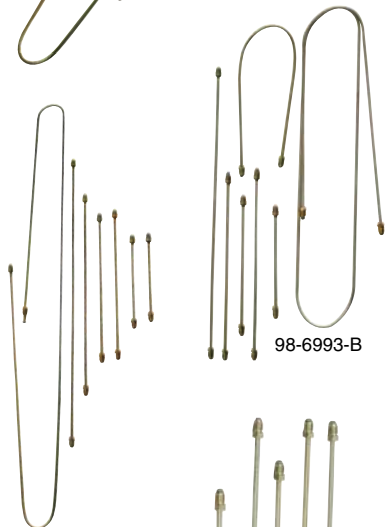

## REPLACEMENT STEEL BRAKE LINE KITS

111 698 700	98-6991-B	Steel Brake Line Kit, Type 1 thru 66
113 698 700	98-6992-B	Steel Brake Line Kit, Type 1 67-68
131 698 700	98-6993-B	Steel Brake Line Kit, Type 1 69-77

98-6991-B



98-6682-B



## REPLACEMENT STEEL BRAKE LINES

All Plated Steel Brake Lines with 6mm fittings in a variety of lengths. Great for replacing your contaminated or damaged stock brake lines or designing new lines for disc brake conversions.

113 611 723A	98-9601-B	Steel Brake Line 7.50", Each
113 611 763A	98-9612-B	Steel Brake Line, 8" Length, Type 1 All, Each
113 611 735D	98-9600-B	Steel Brake Line 10.25", Each
113 611 723JA	98-9613-B	Steel Brake Line, 12" Length, Type 1 All, Each
113 611 781D	98-9614-B	Steel Brake Line, 13" Length, Type 1 All, Each
113 611 781E	98-9615-B	Steel Brake Line, 17" Length, Type 1 All, Each
	98-9616-B	Steel Brake Line, 20" Length, Type 1 All, Each
113 611 764C	98-9617-B	Steel Brake Line, 22" Length, Type 1 All, Each
113 611 764B	98-9618-B	Steel Brake Line, 25" Length, Type 1 All, Each
211 611 723A	98-9619-B	Steel Brake Line, 28" Length, Type 1 All, Each
113 611 724J	98-9620-B	Steel Brake Line, 31" Length, Type 1 All, Each
803 611 755	98-6682-B	T-Piece, Rear Brake Fluid Distributor, Thread Size 10mm x 1.00 Each End, Type 1, 50-79, Ghia, 56-74, Type 3, 64-73, Each



# SUSPENSION & STEERING

**WARNING:** It is extremely important that brake lines be installed by a trained mechanic. Proper length of each line in relation to wheel travel and steering angle is critical to avoid brake failure. Equally important is brake lines must be free flowing and have no contamination. Additionally, all calipers must be bled properly, regardless of kit purchased. Do not attempt brake line or caliper installation without the experience to properly evaluate all of these issues.

## WHEEL CYLINDERS

Don't take a chance on rebuilt Wheel Cylinders. EMPI offers brand new Wheel Cylinders at a price that makes rebuilding a thing of the past.



### EMPI Brand

- 113 611 057BCH**    **98-6214-B**    Front Wheel Cylinder, Type 1, 58-77 (Exc. Super Beetle)
- 361 611 067ACH**    **98-6216-B**    Front Wheel Cylinder, Super Beetle



- 211 611 069CCH**    **98-6217-B**    Front Left Wheel Cylinder, Type 2, 64-70 (2 Required)
- 211 611 070CCH**    **98-6218-B**    Front Right Wheel Cylinder, Type 2, 64-70 (2 Required)



- 113 611 055CCH**    **98-6210-B**    Rear Wheel Cylinder, Type 1, 58-64
- 131 611 055CH**    **98-6213-B**    Rear Wheel Cylinder, Type 1, 65-67
- 113 611 053BCH**    **98-6209-B**    Rear Wheel Cylinder, Type 1, 68-79



- 211 611 047CCH**    **98-6207-B**    Rear Wheel Cylinder, Type 2, thru 71
- 211 611 047FCH**    **98-6208-B**    Rear Wheel Cylinder, Type 2, 72-92
- 311 611 067CCH**    **98-6215-B**    Rear Wheel Cylinder, Type 3, 64-73

**211 611 047DCH**



### VARGA Brand



- 113 611 057B**    **98-6014-B**    Front Wheel Cylinder, Type 1, 58-77 (Exc. Super Beetle) (Varga)
- 361 611 067A**    **98-6016-B**    Front Wheel Cylinder, Super Beetle (Varga)



- 211 611 069C**    **98-6017-B**    Front Left Wheel Cylinder, Type 2, 64-70 (2 Required) (Varga)
- 211 611 070C**    **98-6018-B**    Front Right Wheel Cylinder, Type 2, 64-70 (2 Required) (Varga)



- 113 611 055C**    **98-6010-B**    Rear Wheel Cylinder, Type 1, 58-64 (Varga)
- 131 611 055**    **98-6013-B**    Rear Wheel Cylinder, Type 1, 65-67 (Varga)
- 113 611 053B**    **98-6009-B**    Rear Wheel Cylinder, Type 1, 68-79 (Varga)



- 211 611 047C**    **98-6007-B**    Rear Wheel Cylinder, Type 2, thru 71 (Varga)
- 211 611 047F**    **98-6008-B**    Rear Wheel Cylinder, Type 2, 72-92 (Varga)    **211 611 047D**



- 311 611 067C**    **98-6015-B**    Rear Wheel Cylinder, Type 3, 64-73 (Varga)

## BRAKE SHOE SETS

High quality bonded Brake Shoe Sets. Sold in sets of 4 shoes (Axle Set). (All shoes are new, outright, no core). Industry P/N is now included.



113 609 237A	98-6090-B	Brake Shoe Set, Front or Rear, Type 1, 49-57 (162)
113 609 237D	98-6091-B	Brake Shoe Set, Front, Type 1, 58-64, (167)
131 609 237C	98-6093-B	Brake Shoe Set, Front, Type 1, 65-77 (Exc. S/B), (269)
113 609 237H	98-6092-B	Brake Shoe Set, Front, Super Beetle, 71-79, (392)
113 609 237A	98-6090-B	Brake Shoe Set, Front or Rear, Type 1, 49-57 (162)
113 609 537B	98-6095-B	Brake Shoe Set, Rear, Type 1, 58-64, (168)
131 609 537C	98-6097-B	Brake Shoe Set, Rear, Type 1, 65-67, (270)
113 609 537C	98-6096-B	Brake Shoe Set, Rear, Type 1, 68-79, (315)
211 609 237D	98-6094-B	Brake Shoe Set, Front, Type 2, 64-70, (297)
211 609 537E	98-6098-B	Brake Shoe Set, Rear, Type 2, 64-70, (298)

## BRAKE HARDWARE KITS



131 698 237C	98-6987-B	Brake Hardware Kit, Front, Type 1, 65-77
113 698 237D	98-6986-B	Brake Hardware Kit, Front, Type 1, 58-64
113 698 237H	98-6988-B	Brake Hardware Kit, S/B, Front, Type 1, 71-79
113 698 537B	98-6989-B	Brake Hardware Kit, Rear, Type 1, 58-66, Ghia, 58-66
113 698 537C	98-6990-B	Brake Hardware Kit, Rear, Type 1, 67-79, Ghia, 67-74
311 698 071	98-6881-B	Brake Shoe Hardware Kit, (1 Wheel), Type 1, 65-79, Ghia, 65-74
211 611 477A	98-6023-B	Brake Bleeder Valve, Type 1, 58-79, Ghia, 58-74, Type 3, 66-73, Each
211 611 483	98-6024-B	Brake Bleeder Valve Cap, Type 1, 58-79, Ghia, 58-74, Type 2, 50-79, Vanagon, 80-92, Type 3, 66-73, Each
113 609 205A	98-6115-B	Adjusting Star, Brake Shoe, Type 1, 50-79, Ghia, 56-74, Type 2, 55-79, Type 3, 64-73, Each
131 609 209	98-6116-B	Adjusting Screw, Brake Shoe, Type 1, 65-79, Ghia, 65-74, Type 3, 64-73, Each
211 609 209	98-6117-B	Adjusting Screw, Brake Shoe, Type 1, 58-64, Ghia, 58-64, Type 2, 50-55, Each
803 611 755	98-6682-B	T-Piece, Rear Brake Fluid Distributor, Thread Size 10mm x 1.00 Each End, Type 1, 50-79, Ghia, 56-74, Type 3, 64-73, Each
211 609 601B	98-6118-B	Anchor Pin, Parking Brake Lever (use w/211 609 619), Type 1 50-79, Ghia 56-74, Type 2 55-79, Type 3 64-73, Each
211 609 619	98-6121-B	C Clip, Parking Brake Lever Pin, Type 1 50-79, Ghia 56-74, Type 2 55-79, Type 3 64-73, Each

99% of the calls we received concerning problems with brake installation comes down to 1 problem...**AIR IN THE LINES**. No one wants to hear it, after having bled the system 2 or 3 times...but spongy pedal, pads dragging, etc., almost always is the cause of air trapped in the system.

Be sure to Bench Bleed a new master cylinder if installed. There are a few different '1-Man Bleeders' available - Mityvac and others. Use our new Quick Bleeders...make it easy on yourself and your helpers.

If installing new Disc Brake Calipers, rotate them to where the bleeder is around 12 O'Clock for bleeding...easier to get the air going straight up...then rotate them into position when you are done.

When all else fails, take the car to a professional for bleeding and adjusting. Small price to pay if you do not have the patience!



### Wheel Tech

The applications listed with the wheels in this catalog are very basic. There are many variables when installing aftermarket wheels. Clearance issues - fender, brake, shock tower...wheel stud & lug nut/bolt length, size and more. There may be fitment challenges when mounting aftermarket wheels. Some wheels may require spacers to clear disc brake calipers or a long snout on a brake drum. Some may not fit with certain disc brake kits at all...some may not fit with certain brake Drums. Some may not fit within the fender area with spacers. Measure and calculate as much as possible BEFORE purchasing wheels. Then be certain to fit the wheel on your vehicle BEFORE MOUNTING tires on the wheels. Once tires are mounted, the wheels cannot be returned.

#### EMPI Wheel Patterns, or PCDs:

- 5 X 205 – VW to 1967 (12mm Lug Bolt)
- 4 X 130 – VW 68 & Later (14 mm Lug Bolt)
- 5 X 112 – VW Bus 71 & Later (14mm Lug Bolt)
- 5 X 100 – New Beetle (14mm Lug Bolt)
- 5 X 130 – Porsche Pattern (14mm Lug Nut)  
(which will require wheel adapters or modified drums/rotors for use on a VW)

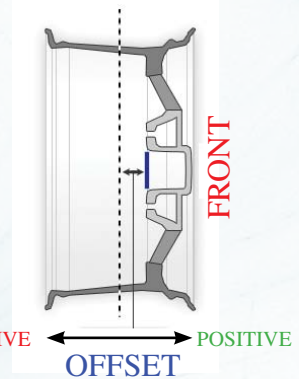

#### Wheel Off-set or ET

Off-set is the distance in mm between the center line of the wheel rim, and the hub mounting surface of the wheel. You can have positive (+), negative (-) or neither (0). Off-set determines the position of the wheel under the fender.

#### How to Measure Wheel Backspace

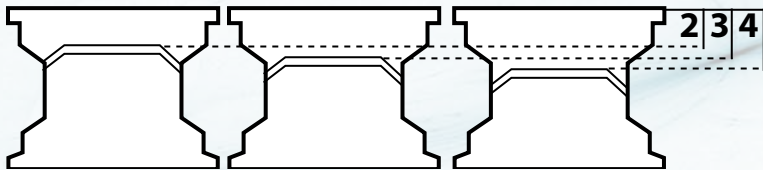

#### Items Required to Measure Wheel Backspace:

- Tape Measure
- Straight Edge
- Wheel w/o Tire (preferred)

The easiest way to measure backspace is to place the wheel face down on the floor so the backside of the wheel is facing up. Lay a straight edge diagonally across the inboard flange of the wheel. With a tape measure, measure the distance from where the straight edge contacts the inboard flange to the hub mounting pad of the wheel. This measurement is backspace. The above drawing shows three wheels with 2", 3", and 4" backspace.

It is imperative that the correct Lug Nuts/Bolts are used to secure the wheel to the vehicle. All Lug Bolts need to be checked to be certain that they are not interfering with internal brake parts. All Lug Nuts need to be checked to be certain that they are in fact tightening the wheel to the rotor/drum and not bottoming out on the stud leaving the wheel loose. This is the responsibility of the installer.

#### Lug Nuts / Bolts

**60° Conical (Tapered) Lug Nuts/Bolts** All EMPI Wheels (except wheels with 5 X 130 PCD) are made for 60° Conical (Tapered) Lug Nuts/Bolts.



#### Ball Seat (Rounded) Lug Nuts/Bolts

All EMPI Wheels with a 5 X 130 PCD are made for Ball Seat (Rounded) Lug Nuts/Bolts as are Bead-Lock and Off-Road Wheels. (Except 5 X 112 PCD Wheels).



#### Small Diameter or "Tuner" Lug Nuts/Bolts

EMPI 5 X 112 and 5 X 100 PCD Wheels are made for Small Diameter or "Tuner" Lug Nuts/Bolts. The PCD is small and close to the center hub, requiring a smaller Lug Nut Bore.





**Identifying Wheel Dimensions**

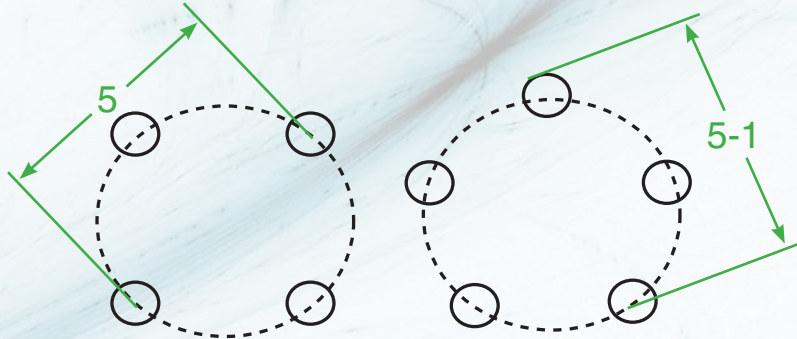
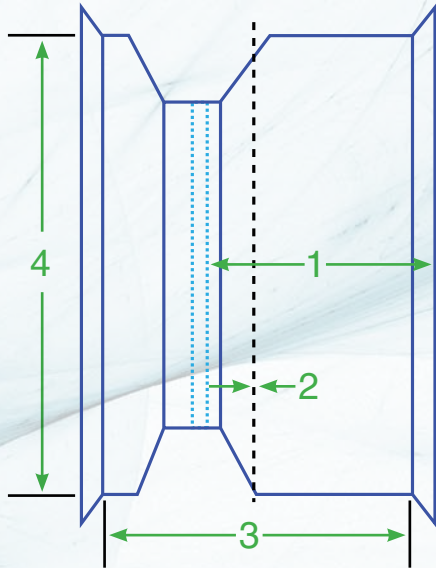

- 1. Back Spacing  
From the inside of the wheel where it contacts the hub to the inside edge of the wheel.
- 2. ET  
From the inside of the wheel where it contacts the hub to the Center of the wheel.
- 3. Rim Width  
From the inside of the outer lip at the bead seating point to the inner lip.
- 4. Rim Diameter  
The measured diameter of the wheel from the bead seating point (not the outer edge).
- 5. PCD - Bolt Pattern  
4-Lug Wheel is a direct measurement.  
5-1. 5-Lug Wheel measures 'approximately' from one hole to the outer edge of the hole diagonally across from it.

**Check for Clearance**

Fender

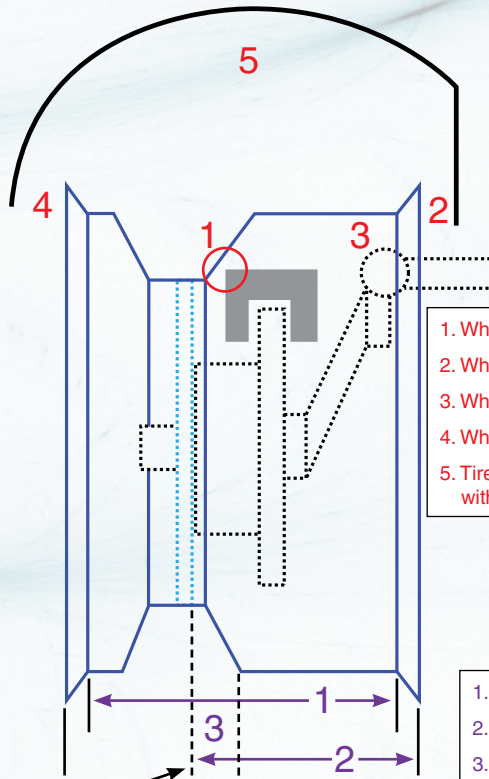

- 1. Wheel and Brake Caliper
- 2. Wheel to Inner Apron / Chassis
- 3. Wheel to Suspension Parts
- 4. Wheel to Outer Fender
- 5. Tire to Fender - with Suspension fully collapsed

- 1. Wheel Width
- 2. Backspacing
- 3. ET

HUB Mounting

Wheel Center

## Proper Lug Bolt Length

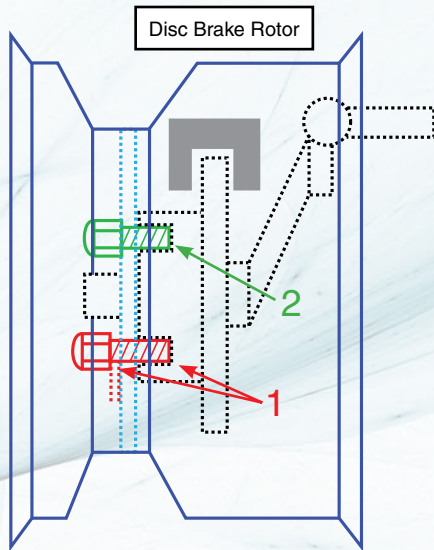

Measure for proper Lug Bolt Length

1. Lug Bolt Length - must not bottom out in hub while leaving a gap - therefore not seating the wheel.
2. Lug Bolt must seat and secure wheel to hub.

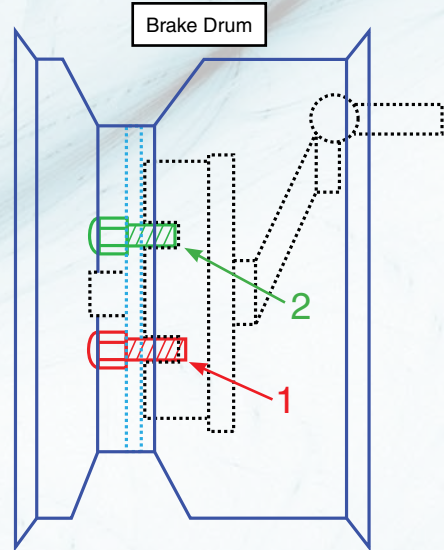

Measure for proper Lug Bolt Length

1. Lug Bolt Length - must not extend into drum and interfere with brake parts.
2. Lug Bolt must seat and secure wheel to hub while not touching internal brake parts.

## Wheel Spacers

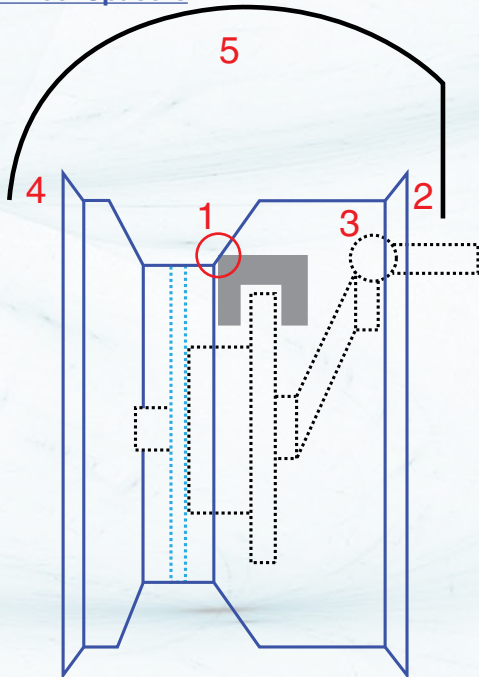

1. Brake Caliper
2. Inner Fender / Apron
3. Suspension
4. Outer Fender

Wheel Spacers...

This example shows that when the wheel is placed on the hub for mounting - the wheel does NOT clear the Brake Caliper.

To gain the necessary clearance, a Wheel Spacer may be used. Install the narrowest Wheel Spacer possible to allow enough clearance between the Wheel and the Brake Caliper.

Remember -adding the Wheel Spacer thickness reduces the off-set and brings the wheel out closer to your fender. You must re-check for ALL other clearance issues.

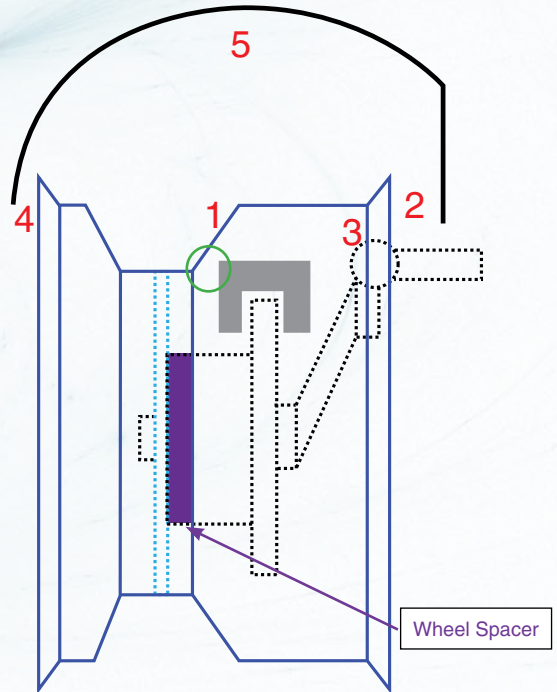

Wheel Spacer

This example shows that when the wheel is placed on the hub for mounting with the addition of a Wheel Spacer - the wheel clears the Brake Caliper.

By adding the Wheel Spacer thickness, the off-set has been reduced and the wheel is now closer to your fender.

You must re-check for ALL other clearance issues.



w/ Ring Installed

# RACE-TRIM BEAD-LOCK WHEELS

w/o Ring

Pressure-Cast Aluminum Wheels with Forged Bead-Lock Rings and Grade 8 Hardware. These wheels are built for the Dirt...and Sand. Wheels feature a Machine finish. All Bead-Lock wheels are drilled and tapped 48 times. Bead-Lock Rings are available in your choice of Polished Aluminum or Powder-Coated Candy Red, Candy Blue or Matte Black.

SIZE (in.)	STYLE	ET	B/S (in.)	SEAT	PCD	P/N
15	4 Machine Finished (wheel only)	-19	1 <sup>3</sup> / <sub>4</sub>	Ball	5x205	9764
	7 Machine Finished (wheel only)	-32	2 <sup>5</sup> / <sub>8</sub>	Ball	5x205	9765
	10 Machine Finished (wheel only)	-32	4 <sup>1</sup> / <sub>8</sub>	Ball	5x205	9766
	12 Machine Finished (wheel only)	-32	5 <sup>1</sup> / <sub>8</sub>	Ball	5x205	9767

## 5x205

- Pressure Cast Aluminum Wheels
- Ball Seat Lugs
- Forged Bead-Lock Rings (Sold Separately)
- Grade 8 Bolts w/ Hardened Washers (Sold Separately)
- **For Off-Road Use Only**

Hardware Sold Separately



**Bead-Lock Hardware should only be used for 1 installation. Discard and install New hardware when removing or replacing Bead-Lock Ring Bolts for any reason.**

24 Grade 8 Bolts, Zinc  
5/16" x 18 x 1" Long  
24 Hardened Washers, Zinc  
For One Wheel and Ring



### EMPI 3" BILLET ALUMINUM WHEEL SPACERS

Extra clearance for a wider tires, larger coil springs or just to compensate for the off-set of your wheels. Will fit EMPI Microstub Brake Kits. These spacers are made from Billet Aluminum, 3" thick and feature dual 5 x 4 3/4" lug patterns with 14mm x 1.5 studs installed.

9485

3" Wheel Spacers, Pair



# BEAD-LOCK RINGS

**POWDERCOATED**

SIZE (IN)	Rings for Bead-Lock wheels	P/N
15	Polished Ring w/o Hardware, Each	9769
15	Candy Red Ring w/o Hardware, Each	9774
15	Candy Blue Ring w/o Hardware, Each	9775
15	Matte Black Ring w/o Hardware, Each	9776
15	Hardware kit for 15" wheel (24 pairs)	9782

*Bead-Lock Hardware should only be used for 1 installation. Discard and install New hardware when removing or replacing Bead-Lock Ring Bolts for any reason.*

## RACE-TRIM OFF-ROAD WHEELS



9761

10-1105

### SPINDLE-MOUNT WHEEL KIT

- Pressure Cast Aluminum Wheels
- Ball Seat Lugs
- For Off-Road Use Only

- Uses stock Link Pin Bearings & Seals. Includes wheel bearings with races installed, seal and chrome dust cap w/ logo.

SIZE (in.)	STYLE	ET	B/S (in.)	SEAT	PCD	P/N
15	4 Machine Finished (wheel only)	-19	1 <sup>3</sup> / <sub>4</sub>	Ball	5x205	9761
	6.5 Machine Finished (wheel only)	-32	2 <sup>5</sup> / <sub>8</sub>	Ball	5x205	9762
16	4 Machine Finished (wheel only)	-19	1 <sup>3</sup> / <sub>4</sub>	Ball	5x205	10-1104
15	4 Spindle Mount Machine Finish (Kit)	0	0	N/A	Link Pin	10-1105





# GASSER

**4x130**



With metal stainless steel cap

**5x112**

**5x130**



**4x130**

*Late Bug / Ghia*

SIZE (in.)	STYLE	ET	B/S (in.)	SEAT	PCD	WEIGHT	P/N
15 5½	Gloss Black w/ Polished Lip & Face	25	4¼	60°	4x130	17	10-1080

Comes w/ chrome logo cap & chrome valve stem.

**5x112**

*Late Bus, 1971 & Later*

SIZE (in.)	STYLE	ET	B/S (in.)	SEAT	PCD	WEIGHT	P/N
15 5½	Gloss Black w/ Polished Lip & Face	20	4	60°	5x112*	17	10-1082

\* Requires Special Lug Nuts - See Page 284

Comes w/ chrome logo cap & chrome valve stem.

**5x130**

*Early Bug, Late Bug / Ghia, Early Bus, Late Bus / Porsche*

SIZE (in.)	STYLE	ET	B/S (in.)	SEAT	PCD	WEIGHT	P/N
15 5½	Gloss Black w/ Polished Lip & Face	45	5	Ball	5x130	17	10-1081

Comes w/ chrome logo cap & chrome valve stem.



4-SPOKE WHEELS

# 4-SPOKE



**LUGNUTS**  
SEE PAGES 283-285

## 4x130 *Late Bug / Ghia*

SIZE (in.)	STYLE	ET	B/S (in.)	SEAT	PCD	WEIGHT	P/N
5½	All Chrome	25	4½	60°	4x130	13½	10-1094
15 5½	Anthracite w/ Polished Lip	25	4½	60°	4x130	13½	10-1093
5½	Matte Black w/ Polished Lip	25	4½	60°	4x130	13½	10-1092

All wheels come with chrome plastic cap w/ logo and chrome valve stem.



# COSMO

**5x112**

Featuring Round Hole Pattern

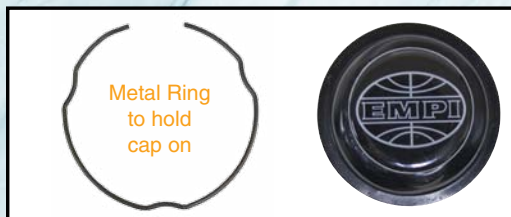

Metal Ring to hold cap on

Black cap w/ black EMPI logo

Featuring Round Hole Pattern



**5x130**



**4x130**

**4x130**

Late Bug / Ghia



**5x205**

Featuring Original "V" Hole Pattern

SIZE (in.)	STYLE	ET	B/S (in.)	SEAT	PCD	WEIGHT	P/N
15 5½	Gloss Black w/ Polished Lip & Face	35	4½	60°	4x130	16	10-1100

Black metal cap with black logo & chrome valve stem.  
Cap & Ring are installed from the Front of the wheel.

**5x112**

Late Bus, 1971 & Later

SIZE (in.)	STYLE	ET	B/S (in.)	SEAT	PCD	WEIGHT	P/N
15 5½	Gloss Black w/ Polished Lip & Face	20	4	60°	5x112*	14	10-1084

\* Requires Special Lug Nuts - See Page 284

Black metal cap with black logo & chrome valve stem.  
Cap & Ring are installed from the Rear of the wheel.

**5x130**

Early Bug, Late Bug / Ghia, Early Bus, Late Bus / Porsche

SIZE (in.)	STYLE	ET	B/S (in.)	SEAT	PCD	WEIGHT	P/N
15 5½	Gloss Black w/ Polished Lip & Face	45	5	Ball	5x130	14	10-1083

Black metal cap with black logo & chrome valve stem.  
Cap & Ring are installed from the Rear of the wheel.

**5x205**

Early Bug / Ghia, Early Bus

SIZE (in.)	STYLE	ET	B/S (in.)	SEAT	PCD	WEIGHT	P/N
15 5½	Gloss Black w/ Polished Lip & Face	22	4½	60°	5x205	17½	10-1101

Black metal cap with black logo & chrome valve stem.  
Cap & Ring are installed from the Front of the wheel.



SMOOTHIE / REVOLVER WHEELS

# SMOOTHIE



**LUGNUTS**  
SEE PAGES 283-285

# REVOLVER

**NEW!**



## 4x130

Late Bug / Ghia

## REVOLVER

**NEW!**

SIZE (in.)	STYLE	ET	B/S (in.)	SEAT	PCD	WEIGHT	P/N
15 5½	Polished	5	3¾	60°	4x130	13	10-1115

All wheels come with chrome plastic cap w/ logo and chrome valve stem.

## 4x130

Late Bug / Ghia

## SMOOTHIE

SIZE (in.)	STYLE	ET	B/S (in.)	SEAT	PCD	WEIGHT	P/N
15 5½	Polished	5	3¾	60°	4x130	13	10-1098

All wheels come with chrome plastic cap w/ logo and chrome valve stem.



# BRM

**CLASSIC BRM'S FOR YOUR NEW BEETLE OR LATE MODEL BUG OR GHIA**



## 5x100 *New Beetle*

SIZE (in.)	STYLE	ET	B/S (in.)	SEAT	PCD	WEIGHT	P/N
17	All Chrome	40	5 3/8	60°	5x100*	21	9737*
	Gloss Black w/ Polished Lip & Spoke Edges	40	5 3/8	60°	5x100*	20 1/2	9736*

\* Comes with chrome plastic cap w/ EMPI logo and chrome valve stem.

\* Requires Special Lug Nuts - See Page 284



## 4x130 *Late Bug / Ghia*

SIZE (in.)	STYLE	ET	B/S (in.)	SEAT	PCD	WEIGHT	P/N
15	Gloss Black w/ Polished Lip & Spoke Edges	15	3 3/4	60°	4x130	12 1/2	9734
	Gloss Black w/ Polished Lip & Spoke Edges	15	3 3/4	60°	4x130	13 1/2	9735

All wheels come with cap and chrome valve stem.



BRM WHEELS

**BRM**



9675



9730



10-1086

**5x205**

Early Bug / Ghia, Early Bus

SIZE (in.)	STYLE	ET	B/S (in.)	SEAT	PCD	WEIGHT	P/N
15	5 All Chrome	14	3 <sup>7</sup> / <sub>16</sub>	60°	5x205	14 <sup>1</sup> / <sub>2</sub>	9722*
	5 Gloss Black w/ Polished Lip & Spoke Edges	14	3 <sup>7</sup> / <sub>16</sub>	60°	5x205	14	9676
	5 Matte Black w/ Matte Silver Lip & Spoke Edges	14	3 <sup>7</sup> / <sub>16</sub>	60°	5x205	14	9675
	6 <sup>1</sup> / <sub>2</sub> All Chrome	12	4 <sup>1</sup> / <sub>8</sub>	60°	5x205	17 <sup>1</sup> / <sub>2</sub>	9730*
	6 <sup>1</sup> / <sub>2</sub> Gloss Black w/ Polished Lip & Spoke Edges	12	4 <sup>1</sup> / <sub>8</sub>	60°	5x205	17	9729
17	7 All Chrome	42	5 <sup>5</sup> / <sub>8</sub>	60°	5x205	20	10-1087*
	7 Gloss Black w/ Polished Lip & Spoke Edges	42	5 <sup>5</sup> / <sub>8</sub>	60°	5x205	18	10-1086

All wheels come with cap and chrome valve stem.

\* Comes with chrome cap and chrome valve stem.



**5x112**

Late Bus  
1971 & Later

SIZE (in.)	STYLE	ET	B/S (in.)	SEAT	PCD	WEIGHT	P/N
15	5 <sup>1</sup> / <sub>2</sub> All Chrome	12	3 <sup>5</sup> / <sub>8</sub>	60°	5x112*	16 <sup>1</sup> / <sub>2</sub>	9731*
	5 <sup>1</sup> / <sub>2</sub> Gloss Black w/ Polished Lip & Spoke Edges	12	3 <sup>5</sup> / <sub>8</sub>	60°	5x112*	16	9697
17	7 All Chrome	40	5 <sup>1</sup> / <sub>2</sub>	60°	5x112*	20	10-1089*
	7 Gloss Black w/ Polished Lip & Spoke Edges	40	5 <sup>1</sup> / <sub>2</sub>	60°	5x112*	18	10-1088

All wheels come with cap and chrome valve stem.

\* Comes with chrome cap and chrome valve stem.

\* Requires Special Lug Nuts - See Page 284



9697



10-1089



Tall Cap (P/N 9704)  
1 1/4" Tall  
Sold Separately  
See Page 276



Back of Cap Ring

# 911 ALLOY WHEELS



**15"**



9694

**17"**



9745



Logo on Cap for all 911 Alloy Wheels

**5x112** Late Bus 1971 & Later

SIZE (in.)	STYLE	ET	B/S (in.)	SEAT	PCD	WEIGHT	P/N
15	All Chrome	20	4	60°	5x112*	16½	9694
	Matte Black w/Matte Silver*	20	4	60°	5x112*	15½	9728
17	All Chrome	40	5½	60°	5x112*	22	9744
	Matte Black w/Matte Silver*	40	5½	60°	5x112*	21	9745

Chrome & Polished wheels come w/ chrome logo cap & chrome valve stem. Black/Silver wheels come w/ silver logo cap & chrome valve stem.

\* Clear-Coated w/ matching Silver Cap.

\* Requires Special Lug Nuts - See Page 284

**5x205** Early Bug, Ghia, Early Bus

SIZE (in.)	STYLE	ET	B/S (in.)	SEAT	PCD	WEIGHT	P/N
15	Polished w/Black	20	3½	60°	5x205	13	10-1108
	All Chrome	20	3½	60°	5x205	14	10-1109
	Polished w/Black	20	4	60°	5x205	14	10-1110
	All Chrome	20	4	60°	5x205	15	10-1111

Chrome & Polished wheels come w/ chrome logo cap & chrome valve stem.

**LUGNUTS**  
SEE PAGES 283-285



10-1108

**5x205**

10-1111





# 911 ALLOY WHEELS

## 5x130

Early Bug, Late Bug / Ghia, Early Bus, Late Bus / Porsche

SIZE (in.)	STYLE	ET	B/S (in.)	SEAT	PCD	WEIGHT	P/N
15	4½ All Chrome	45	4½	Ba11	5x130	15	9677
	4½ Polished	45	4½	Ba11	5x130	14½	9678
	4½ Matte Black w/Matte Silver*	45	4½	Ba11	5x130	14½	9726
	5½ All Chrome	45	4 <sup>15</sup> / <sub>16</sub>	Ba11	5x130	16	9679
	5½ Polished	45	4 <sup>15</sup> / <sub>16</sub>	Ba11	5x130	15½	9680
	5½ Matte Black w/Matte Silver*	45	4 <sup>15</sup> / <sub>16</sub>	Ba11	5x130	15½	9727
	6 All Chrome (Different Spoke Design)	35	4 <sup>7</sup> / <sub>8</sub>	Ba11	5x130	16	10-1102
	6 Polished (Different Spoke Design)	35	4 <sup>7</sup> / <sub>8</sub>	Ba11	5x130	15	10-1103
17	7 All Chrome	40	5½	Ba11	5x130	22	9738
	7 Matte Black w/Matte Silver*	40	5½	Ba11	5x130	21	9739

Chrome & Polished wheels come w/ chrome logo cap & chrome valve stem. Black/Silver wheels come w/ silver logo cap & chrome valve stem.

\* Clear-Coated w/ matching Silver Cap.



### 15"

9677

9727

9679

10-1102  
(Different Spoke Design)  
15"x6"



# 911 ALLOY



Logo on Cap for all 911 Alloy Wheels



### 17"

9739

9738







**LUGNUTS**  
SEE PAGES 283-285

# TORQUE STAR

Early Bug / Ghia, Early Bus **5x205**

SIZE (in.)	STYLE		ET	B/S (in.)	SEAT	PCD	WEIGHT	P/N
15	5	All Chrome	16	3 1/2	60°	5x205	14	9755
	5	Anthracite w/ Polished Lip	16	3 1/2	60°	5x205	13	9754

All wheels come with chrome plastic cap w/ logo and chrome valve stem.

**Clearancing or Spacers may be necessary for some disc brake calipers. Be certain to check for clearance. Will fit all drum brakes on Type 1.**





**4x130**



**5x205**

**5x112**

*Late Bus, 1971 & Later*

# EMPI DISH

*Early Bug / Ghia, Late Bug / Ghia, Late Bus*

**LUGNUTS**  
SEE PAGES 283-285

SIZE (in.)	STYLE	ET	B/S (in.)	SEAT	PCD	WEIGHT	P/N
15	Machine Finished	17	3 <sup>3</sup> / <sub>4</sub>	60°	4x130	14 <sup>1</sup> / <sub>2</sub>	9748
	Machine Finished	23	4	60°	5x112*	14 <sup>1</sup> / <sub>2</sub>	9749
	Machine Finished	23	4	60°	5x205	12	9747

All wheels come with chrome plastic cap w/ logo and chrome valve stem.

\* Requires Special Lug Nuts - See Page 284





**5x205**



# GT-5

*Early Bug / Ghia, Early Bus, Late Bus*



SIZE (in.)	STYLE	ET	B/S (in.)	SEAT	PCD	WEIGHT	P/N
15	5½ All Chrome	20	4	60°	5x205	16	9686
	5½ Polished	20	4	60°	5x205	15	9687
	5½ Gloss Black w/ Polished Lip	20	4	60°	5x205	15	9690
	5½ Silver w/ Polished Lip	20	4	60°	5x205	15	9691
	5½ All Matte Black w/ Matching Cap	20	4	60°	5x112*	15	9662
	5½ All Chrome	20	4	60°	5x112*	16	9696
	5½ Silver w/ Polished Lip	20	4	60°	5x112*	15	9695

Wheels come with chrome plastic cap w/ logo, chrome valve stem, and stainless steel cap screws.

All Matte Black wheels come with black plastic cap w/ logo, chrome valve stem, and stainless steel cap screws.

\* Requires Special Lug Nuts - See Page 284





GT-5 WHEELS



**5x112**

Late Bus, 1971 & Later





**LUGNUTS**  
SEE PAGES 283-285

**4x130** **GT-8**  
Late Bug / Ghia

**YOU CAN PAINT TO MATCH YOUR RIDE**

SIZE (in.)	STYLE	ET	B/S (in.)	SEAT	PCD	WEIGHT	P/N
15	All Chrome	30	4 <sup>3</sup> / <sub>8</sub>	60°	4x130	15	9683
	Polished	30	4 <sup>3</sup> / <sub>8</sub>	60°	4x130	14 <sup>1</sup> / <sub>2</sub>	9684
	Gloss Black w/ Polished Lip	30	4 <sup>3</sup> / <sub>8</sub>	60°	4x130	14 <sup>1</sup> / <sub>2</sub>	9682
	Silver w/ Polished Lip	30	4 <sup>3</sup> / <sub>8</sub>	60°	4x130	14 <sup>1</sup> / <sub>2</sub>	9685

Wheels come with chrome plastic cap w/ logo, chrome valve stem, and stainless steel cap screws.



Standard Cap  
Packaged w/ Wheel  
5/8" Inside Height



Tall Cap (P/N 10-1106)  
3/8" Additional Clearance  
for Drums / Rotors with  
Longer Snout  
1" Inside Height  
Sold Separately  
See Page 277

**4x130**

# RIVIERA

Late Bug / Ghia



SIZE (in.)	STYLE	ET	B/S (in.)	SEAT	PCD	WEIGHT	P/N
15	All Chrome	17	3 <sup>7</sup> / <sub>8</sub>	60°	4x130	15	9746
	Gloss Black w/ Polished Lip & Spokes	17	3 <sup>7</sup> / <sub>8</sub>	60°	4x130	14 <sup>1</sup> / <sub>2</sub>	9732

All wheels come with chrome plastic cap w/ logo and chrome valve stem.



**BRM REPLACEMENT CAPS**

Note	Part #
Low Cap w/ BRM, EMPI, & Speedwell, Cap Only *	<b>9705</b>
Chrome Low Cap w/ BRM, EMPI, & Speedwell, Cap Only *	<b>9715</b>
Tall Cap 1¼" w/ BRM, EMPI, & Speedwell, Cap Only	<b>9704</b>
Chrome Plastic Low Cap w/ EMPI Logo, New Beetle Only **	<b>9733</b>

\* Supplied with Wheels

Push-On Aluminum Cap with Metal Ring

\*\* Push-On Chrome Plated Plastic Cap with Metal Ring



9705\*



9715\*



9704



Backside



9733\*\*

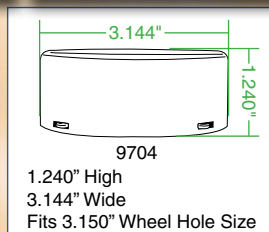

**911 ALLOY & GASSER REPLACEMENT CAPS**

Note	Part #
Chrome Stainless Steel Cap (EMPI Logo), Cap Only *	<b>9718</b>
Silver Cap (EMPI Logo), Cap Only *	<b>9717</b>

\* Supplied with Wheels

Push-On Metal Cap



\*9718



\*9717



\*Chrome and Silver Caps

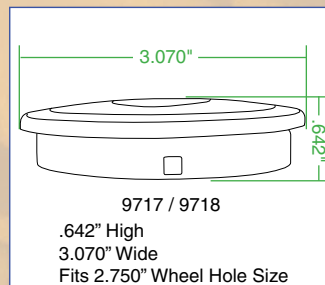

**911 ALLOY & GASSER BILLET EXTENDED WHEEL CAP**

Note	Part #
Polished Billet Aluminum with the EMPI logo Chrome Stainless Steel Cap for use with the 911 & Gasser style wheels when extra clearance is required for those long-snout drums or rotors. 1" Deep Inside and attaches to the wheel with provided Allen Screws. <b>(Not Supplied with wheel)</b>	
911 & Gasser Billet Extended wheel Caps, Pair* <b>NEW!</b>	<b>10-1107</b>

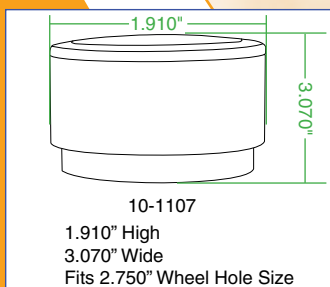

Installed

**NEW!**

10-1107



# REPLACEMENT CAPS

## SPRINTSTAR, RIVIERA, & 914 REPLACEMENT CAP

Note

Part #

Cap Only w/ EMPI Logo, Push-On Chrome Plated Plastic w/ Ring  
Standard Cap Packaged w/ wheel, 5/8" Inside Height\*

9707

Tall Cap Only w/ EMPI Logo  
Push-On Chrome Plated Plastic w/ Ring **(Not Supplied with wheel)**

10-1106\*

3/8" Additional Clearance for Drums / Rotors with Longer Snout, 1" Inside Height

\*Supplied with wheels

\*See pages 266, 271 and 275 for information

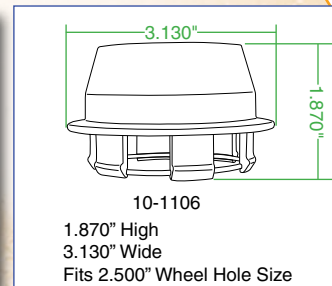
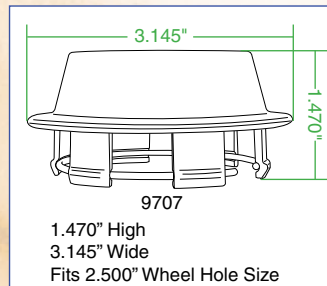

## 5-RIB & GT-5 REPLACEMENT CAP

Note

Part #

Chrome Cap Only w/ EMPI Logo and S/S Hardware, Chrome Plated Plastic

9709

Black Cap Only w/ Black EMPI Logo and S/S Hardware

9641

S/S Allen Bolts for Center Cap, Package of 5

9698

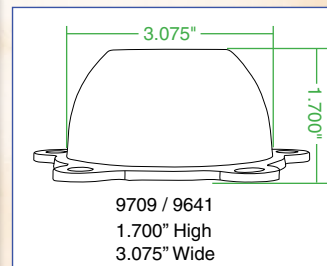

## TORQUE STAR & EMPI DISH REPLACEMENT CAP

Note

Part #

Cap Only w/ EMPI Logo  
Push-On Chrome Plated Plastic with Ring

9720

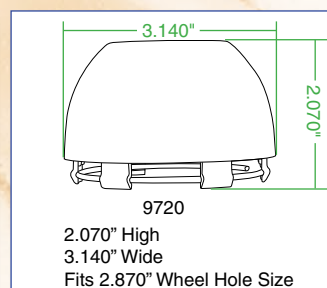



**COSMO REPLACEMENT CAP**

Note  
 Cap Only w/ Black EMPI Logo, Black Metal with Metal Ring Part # **10-1097**

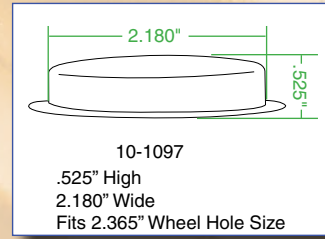

**4-SPOKE REPLACEMENT CAP**

Note  
 Cap Only w/ EMPI Logo, Chrome Plated Plastic Part # **10-1096**

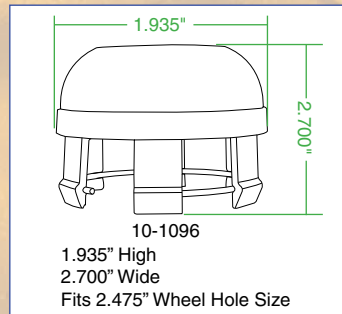

**RAIDER REPLACEMENT CAP**

Note  
 Cap Only (Plain) for 15" Raider, Push-On Chrome Plated Plastic with Ring Part # **9721**  
 Black Cap Only (Plain) for 15" Raider, Push-On Plastic with Ring **9642**  
 Cap Only (Plain) for 17" Raider, Push-On Chrome Plated Plastic with Ring **10-1095**

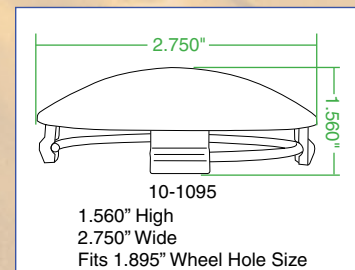
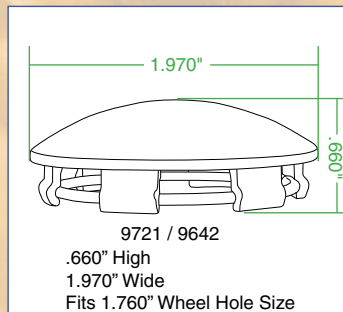



## GT-8 REPLACEMENT CAP

Note

Chrome Cap Only w/ EMPI Logo and S/S Hardware, Chrome Plated Plastic

Part #

**9708**

Black Plastic Cap Only w/ Black EMPI Logo and S/S Hardware

**9643**

S/S Allen Bolts for Center Cap, Package of 5

**9698**

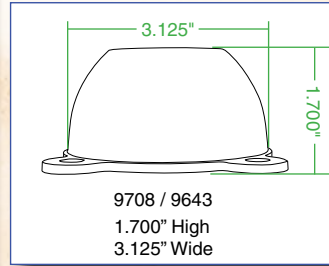

## SMOOTHIE REPLACEMENT CAP

Note

Cap Only w/ EMPI Logo, Chrome Plated Plastic

Part #

**10-1099**

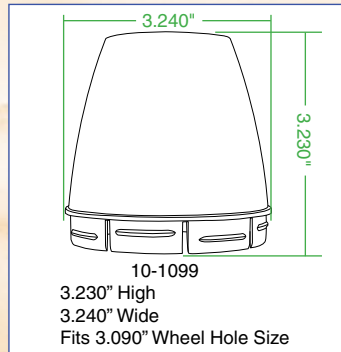

## VALVE STEMS

Chrome Valve Stem with Hex Cap - same stem that is supplied with EMPI wheels.

9710

Chrome Valve Stems, Set of 4

## CHROME SPOKE STEEL WHEELS

Gleaming Chrome Spoke Wheels. Available in 4 & 5 Lug and 6 widths.

Valve Stem hole is 11.3mm.

(See pages 283-285 for chrome lug bolts, locks....etc.)



Part No.	Size / Spec	Back Spacing
10-1008	4 Lug 15 x 5" Wide	2 1/2"
10-1009	4 Lug 15 x 6" Wide	3 3/4"
10-1010	4 Lug 15 x 7" Wide	3 1/2"
10-1011	4 Lug 15 x 8" Wide	2"
10-1012	4 Lug 15 x 10" Wide	2"
10-1020	5 Lug 15 x 5" Wide	2 7/8"
10-1021	5 Lug 15 x 6" Wide	3 1/4"
10-1022	5 Lug 15 x 7" Wide	3 1/2"
10-1023	5 Lug 15 x 8" Wide	3"
10-1024	5 Lug 15 x 10" Wide	3 1/2"

## WHITE SPOKE STEEL WHEELS

Powder-Coated White Spoke Wheels. Available in 4 & 5 Lug and 5 widths.

Valve Stem hole is 11.3mm.

(See pages 283-285 for chrome lug bolts, locks....etc.)



Part No.	Size / Spec	Back Spacing
10-1002	4 Lug 15 x 5" Wide	2 1/2"
10-1003	4 Lug 15 x 6" Wide	3 3/4"
10-1004	4 Lug 15 x 7" Wide	3 1/2"
10-1005	4 Lug 15 x 8" Wide	2"
10-1006	4 Lug 15 x 10" Wide	2"
10-1014	5 Lug 15 x 5" Wide	2 7/8"
10-1015	5 Lug 15 x 6" Wide	3 1/4"
10-1016	5 Lug 15 x 7" Wide	3 1/2"
10-1017	5 Lug 15 x 8" Wide	3"
10-1018	5 Lug 15 x 10" Wide	3 1/2"

## CHROME WHEEL CAPS

Chrome caps are the finishing touch for 4 Lug and 5 Lug Steel Spoke Wheels.



9623	Chrome / Metal Wheel Caps for 5 Lug Steel Wheels, Pair
10-1062	Chrome / Metal Wheel Caps for 4 Lug Steel Wheels, Each





# WHEELS & TIRES

## RACE-TRIM CAST ALUMINUM SPINDLE-MOUNT WHEELS

Light-weight rails and buggies can shed pounds eliminating front brakes, drums or rotors by using our Pressure Cast Aluminum Spindle-Mount Wheels. Uses stock Link Pin Bearings & Seals - and includes Bearings with Races installed, Seal and Chrome Dust Cap w/ Logo.

**Cast Aluminum Spoke Wheels are recommended for light-weight rails and buggies ONLY. Off-Road use ONLY.**

- 10-1105 Cast Aluminum Spindle-Mount Wheel, 15x4, Machined Finish for Link Pin. Bearing Races Installed - includes Bearings, Seal and Chrome Center Cap w/ Logo



10-1105

## CENTER CAPS FOR SPINDLE-MOUNT WHEELS

- 9622 Chrome Center Cap for EMPI Cast and Polished Aluminum Spindle-Mount Wheels, w/o Logo, Pair.
- 10-1029 Alum. Center Cap for Polished Aluminum Spindle-Mount Wheels, Pair (Will not fit with Cast Spindle-Mount Wheels)



9622

10-1029

## SEALED WHEEL BEARINGS FOR SPINDLE-MOUNT WHEELS

- 10-1001 Sealed Wheel Bearings for Polished Aluminum Spindle-Mount Wheels 52mm O.D. Both Sides. Includes 2 Inner & 2 Outer. (Will not fit with EMPI Cast Spindle-Mount Wheels)
- 98-4046-B Link Pin Bearing Spacer, Each (Ref P/N: 111 405 631B)



98-4046-B

10-1001

## ALUMINUM LINK PIN CLAMP NUTS

Machined Aluminum nuts for all Link Pin front spindles.

- 9616 Aluminum Link Pin Clamp Nuts, Pair



9616

## ALUMINUM CENTER HUBS

When front brakes are not needed, lighten the load by eliminating the weight of a brake drum and shoes while running your bolt-on wheels. Choose for use with VW Kingpin Spindles or our Combo Spindles (P/N 16-2518).

- 10-1033 Aluminum Hub 5 on 205 for VW Spindle Uses stock bearings P/N 98-4625-B / P/N 98-4626-B and seal P/N 98-4618-B
- 10-1034 Aluminum Hub 5 on 205 for Combo Spindle Uses combo bearings P/N 17-2797-0 / P/N 17-2798-0 and seal P/N 98-5021-B



10-1033

## ALUMINUM WHEEL SPACERS

Aluminum wheel spacers. Available in 5x205, Double-Drilled 4x130/5x130, and 5x112. You must always use the correct length studs or lug bolts.

- 16-9925 Aluminum Wheel Spacer, 5x205, 3/8" Thick, Pair
- 16-9926 Aluminum Wheel Spacer, Double Drilled 4x130/5x130, 3/8" Thick, Pair
- 16-9915 Aluminum Wheel Spacer, 5/112, 3/8" Thick, Pair
- 16-9930 **NEW!** Aluminum Wheel Spacer, 5x205, 1" Thick, Casting, Pair



16-9915

16-9926

16-9925

16-9930



## WHEEL ADAPTERS

Allows use of popular wheels without drilling drums or hubs.

- 9502** Chevy. Wheel to 5 Lug VW, Steel, Pair  
(Chevy. 4 3/4" Pattern, 7/16" x 20 Thread)
- 9503** VW 4 Lug Wheel to 5 Lug VW, Steel, Pair  
(1/2" x 20 Thread)
- 9504** Chevy Wheel to 4 Lug VW, **Aluminum**, Pair  
(Chevy. 4 3/4" Pattern, 7/16" x 20 Thread) Studs Included
- 9505** Ford Wheel to 5 Lug VW, Steel, Pair  
(Ford 4 1/2" Pattern, 1/2" x 20 Thread)
- 9506** VW 5 Lug Wheel to 4 Lug VW, Steel, Pair  
(Tapped Holes are 12mm x 1.5)
- 9499** 911 Porsche Wheel to 5 Lug VW, Steel, Pair  
(14mm x 1.5 Thread)
- 9500** 911 Porsche Wheel to 4 Lug VW, **Aluminum**, Pair  
(14mm x 1.5 Thread) Studs Included  
[Must use P/N: 70-2863 studs listed on page 285 for mounting](#)
- 9481** VW 5 Lug Wheel to 5x130, Steel, Pair  
(Tapped Holes are 14mm x 1.5 Thread)
- 9482** VW 5 Lug Wheel to 5x112, Steel, Pair  
(Tapped Holes are 14mm x 1.5 Thread)
- 9580** Replacement Off-Set Stud for P/N 9504, Each
- 9588** Replacement Standard Stud for P/N 9504, Each



## FLUSH MOUNT VALVE STEMS

Using these Flush Mount Valve Stems adds to the appearance of any custom wheel. Stem adapter is attached for inflation and replaced by a smooth cap for a smooth, clean look.

- 9514** Flush Mount Valve Stems, Set of 4



## TAPERED ALUMINUM LUG WASHERS

These tapered aluminum washers allow correct seating of lug bolts or nuts on thin walled flat surface aluminum off road wheels. For use with 14mm studs.

- 10-1035** Tapered **Aluminum** Lug Washers, Set of 5



## VALVE STEMS

Chrome Valve Stem with Hex Cap - same stem that is supplied with EMPI wheels.

- 9710** Chrome Valve Stems, Set of 4

## SCISSOR JACK

Originally made for Type 2's, but will work on Sedans & Ghias offering extra jacking height. Great for use on lowered cars.

- 98-0109-B** Scissor Jack Type 2 & Type 1, Each  
(Ref P/N: 237 011 031)



# WHEELS & TIRES

## WHEEL STUDS & CHROME LUG NUTS

Make changing tires a little easier by installing studs on your drums or rotors. Easy installation. No drilling required. Available for use with steel or mag wheels. The lug nuts listed in this section have a 13/16" hex heads.

- 9515 Wheel Studs, M14-1.5 to 1/2-20, Set of 4
- 9516 Wheel Studs, M12-1.5, Both Ends, Set of 5
- 9517 Wheel Studs, M14-1.5, Both Ends, Set of 5 (Porsche)
- 9484 Wheel Studs, M14-1.5, Both Ends, Set of 4
- 9483 Wheel Studs, M12-1.5 to 7/16, Set of 5 (Chev)
- 9535 Chrome Lug Nuts, 1/2-20, Acorn Style (Set of 4)
- 9536 Chrome Lug Nuts, 1/2-20 (for Mag Wheels, Set of 4)
- 9537 Chrome Lug Nuts, M12-1.5, Acorn Style (Set of 5)
- 9538 Chrome Lug Nuts, M12-1.5 (for Mag Wheels, Set of 5)
- 9519 Chrome Lug Nuts, M14-1.5, Acorn Style (Set of 4)
- 9512 Chrome Lug Nuts, 7/16", RH, Acorn Style (Set of 5)
- 9513 Chrome Lug Nuts, 7/16", RH (for Mag Wheels, Set of 5)
- 9533 Chrome Nut & Stud Kit, M12-1.5 (for Steel Wheels, 5 Pair)
- 9534 Chrome Nut & Stud Kit, M14-1.5 to 1/2-20 For Steel Wheels, 4 Pair
- 9510 Chrome Nut & Stud Kit, w/ Flat Washers M12-1.5, 5 Pair
- 9511 Chrome Nut & Stud Kit, w/ Flat Washers, M14-1.5 to 1/2-20, 4 Pair
- 9508 Lug Bolt Adapter Washers Only, (60° Acorn to Metric Ball Seat), Set of 4
- 9509 Lug Bolt Washers Only, Flat, Set of 5



P/N	Wheel Side	Rotor Side
9515	1 1/8" - 30mm	3/8" - 10mm
9516	1 1/8" - 30mm	3/8" - 10mm
9517	1 1/8" - 30mm	3/8" - 10mm
9483	1 1/8" - 30mm	1" - 25mm
9484	1 1/8" - 30mm	3/8" - 10mm

**Note: Some Nuts, Studs and Washers are available in Bulk.**  
Ask sales person for details.

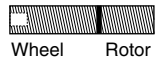

## CHROME STEEL LUG NUTS - 60° SEAT

Now you can have the look of Porsche-Style Lug Nuts for your EMPI or aftermarket wheels featuring 60° seat. Made of Steel with Chrome finish and have a 19mm Hex head. Available in both 12 & 14mm.

- 70-2870 Chrome Steel 60° Lug Nuts 12mm, Set of 5
- 70-2872 Chrome Steel 60° Lug Nuts 14mm, Set of 4



All Lug Bolts need to be checked to be certain that they are not interfering with internal brake parts. Grinding for clearance may be necessary and is the responsibility of the installer.



## 60° CHROME LUG BOLTS

60° Taper fits most new EMPI and other aftermarket custom wheels. Quality chrome finish. These bolts have 19mm Hex Heads and 24mm threaded area. Remember to check for proper clearance.

- 9711** Chrome Lug Bolts - 12mm, 60°, Set of 5  
For EMPI 5x205 wheels
- 9712** Chrome Lug Bolts - 14mm, 60°, Set of 4  
For EMPI 4x130 wheels



## BALL SEAT CHROME LUG BOLTS

Replace your stock lug bolts with Chrome Lug Bolts. Comes in a variety of lengths for a positive fit. Remember to check for proper clearance. All these Bolts have a 22mm Head and Ball Seat.

- 9564** Chrome Lug Bolts - M12-1.5, 15mm Long, Set of 5, Steel Wheels
- 9565** Chrome Lug Bolts - M12-1.5, 20mm Long, Set of 5,  
Steel / Aluminum Wheels
- 9568** Chrome Lug Bolts - M14-1.5, 20.5mm Long, Set of 4,  
Steel / Aluminum Wheels



## CHROME LUG NUTS (SMALL O.D.)

Known as "Tuner" style, these Chrome Lug Nuts are small in diameter and will accommodate a smaller lug hole - as used on 5x112 and 5x100 wheels where the Bolt Pattern is tight.

- 9547** 14mm Small Dia, 60°, for all 5x112 wheels  
Chrome w/ tool, Set of 5
- 9548** 1/2" Small Dia, 60°, for all 5x112 wheels  
Chrome w/ tool, Set of 5
- 9549** 12mm Small Dia, 60°, for all 5x112 wheels  
Chrome w/ tool, Set of 5



## 60° LONG LUG BOLTS

Wheels with Spacers add up to the need for Longer Lug Bolts. These 12mm, 60° Seat Long Lug Bolts give you 47mm total shaft length. Check to make certain that they don't interfere with brake components inside the drum – trim as necessary.

- 70-2875** Long Lug Bolts - 12mm, Set of 5

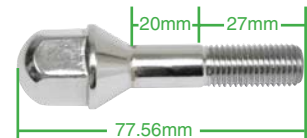

## LONG WHEEL STUDS

Wheels with Spacers add up to the need for Longer Wheel Studs. These 12 & 14mm, Long Wheel studs give you an extra 5mm (3/16") on the Wheel Side of the Stud to help compensate – that's nearly 1/2" longer than our Standard Wheel Studs. Because they are Studs, they don't interfere with brake components inside the drum.

- 70-2876** Long Wheel Studs, M14-1.5 to 1/2-20, Set of 4
- 70-2877** Long Wheel Studs, M12-1.5 Both Ends, Set of 5
- 70-2878** Long Wheel Studs, M14-1.5 Both Ends, Set of 5



P/N	Wheel Side	Rotor Side
70-2876	34mm	11mm
70-2877	35mm	10mm
70-2878	35mm	10mm

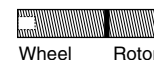

All Lug Bolts need to be checked to be certain that they are not interfering with internal brake parts. Grinding for clearance may be necessary and is the responsibility of the installer.



## EMPI COMPETITION STUDS & NUTS

Quality studs are chamfered for brake shoe clearance and feature a starting shoulder for easy nut alignment. Available for Drum or Disc Brake applications. Requires machining for press fit installation. A 9/16" drill bit should be used, may require reaming to 37/64". The Porsche style nut has a 19mm hex head.

- 70-2850 Stud - Drum, M14-1.5 x 1.855" Long, Black. Set of 5
- 70-2810 Stud - Disc, M14-1.5 x 2.20" Long, Black, Set of 5

- 70-2860 Porsche-Style Nut, Zinc, M14-1.5, Ball Seat, Set of 5
- 70-2860-7 Bulk Porsche-Style Nut, Zinc, M14-1.5, Ball Seat, Ea.  
(Ref. P/N: N020 112 1)



## ALUMINUM ALLOY LUG NUTS

If you have Porsche Alloy's or the desire for a quality lug nut then we have you handled. Lug nuts are made from aluminum alloy and are available black anodized or chromed aluminum, which can easily be polished. Both are M14-1.5 x 1 1/4" long thread and are for the original metric ball seat mounting type. These alloy lug nuts have a 19mm hex head.

- 70-2865 Porsche Style Alloy Lug Nuts, Aluminum, Black Anodized, Set of 5
- 70-2867 Porsche Style Alloy Lug Nuts, Aluminum, Chrome Finish, Set of 5



## CHROME STEEL LUG NUTS

These steel lug nuts are 14mm with a 19mm hex head, with ball seat.

- 70-2868 Porsche Style Alloy Lug Nuts, Steel with Chrome Finish, Set of 5



## LONG CHROME LUG NUTS

1 3/4" thread length capability allows these chrome steel 60 degree acorn style lug nuts ample clearance for most applications that have long press in studs. These are also very popular for play cars and race cars where deep dish rims make it difficult to remove and install standard depth lug nuts. These lug nuts have a 19mm hex head.

- 70-2862 Chrome Lug Nuts, M14-1.5 x 1 3/4" Long, Set of 5



## 14MM VW STYLE LUG BOLT WITH 17MM HEAD

Ever had a problem with the socket being too big to fit into the hole in your wheel adapters? This new lug bolt is the answer to that problem. These nuts are zinc plated, M14-1.5 x 21mm long under the head. A 14mm thread bolt with the smaller 17mm head allows the socket to fit into wheel adapters including EMPI P/N: 9500.

- 70-2863 14mm VW Style Lug Bolt w/17mm Head, Set of 5



## CHROME WHEEL LOCKS

Chrome Wheel Locks to protect your wheels. All EMPI locks are the "socket type" which helps limit stripping out. Supplied with tool.

- 70-2700 M12-1.5, VW Bolt Type, Ball Seat, 29mm Threaded Area, Set of 4
- 70-2701 M14-1.5, VW Bolt Type, Ball Seat, 28mm Threaded Area, Set of 4
- 70-2702 M12-1.5, Mag Nut, Set of 4
- 70-2703 1/2-20, Mag Nut, Set of 4
- 70-2704 1/2-20, Acorn Nut, Set of 4
- 70-2705 M12-1.5, Acorn Nut, Set of 4
- 70-2706 12mm-1.5, 60°, Bolt, 23mm threaded area, Set of 4
- 70-2707 14mm-1.5, 60°, Bolt, 23mm threaded area, Set of 4
- 70-2708 14mm-1.5, Ball Seat for 911 Alloys, Bolt, 25mm threaded area, Set of 4



All Lug Bolts need to be checked to be certain that they are not interfering with internal brake parts. Grinding for clearance may be necessary and is the responsibility of the installer.



10-1070-B

10-1071-B

10-1072-B

## CASTLE-DESIGN HUBCAPS

Mirror finish chrome embossed with an iconic 'Castle' design. Fits stock VW and stock-style chrome wheels

**10-1070-B**

Castle-Design Hubcap, 5 Lug to 65, Bulk, Each

**10-1071-B**

Castle-Design Hubcap, 5 Lug to 66-67, Bulk, Each

**10-1072-B**

Castle-Design Hubcap, 4 Lug to 68-79, Bulk, Each



## CHROME "SMOOTHIE" HUB CAP

Chrome smoothie for that clean finish. Fits any stock VW wheel or stock style chrome wheels.

**10-1060**

Chrome Smoothie Cap, 4 Lug, Each

**10-1060-B**

Bulk Chrome Smoothie Cap, 4 Lug, Each

**10-1061**

Chrome Smoothie Cap, 5 Lug, Each

**10-1061-B**

Bulk Chrome Smoothie Cap, 5 Lug, Each



10-1063

## EMPI STOCK STYLE HUB CAPS

We've incorporated the EMPI globe logo into the stock hub cap design to make a great looking alternative to original hub caps. High luster chrome compliments painted or chrome stock type wheels.

**10-1063**

EMPI Stock Style Hub Cap, 4 Lug, Each

**10-1063-B** **NEW!**

Bulk EMPI Stock Style Hub Cap, 4 Lug, Each

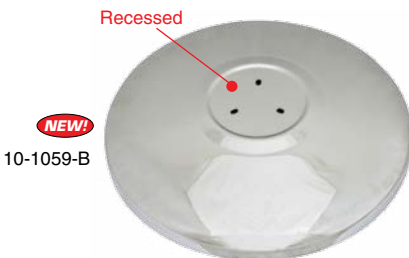

10-1059-B

## STOCK STYLE HUB CAP W/ HOLES

Chrome hub cap available for 4-Lug stock VW Wheels. Drilled for your choice of crests. Will also fit most chrome aftermarket VW Wheels. [See page 287 for crests.](#)

**10-1059-B** **NEW!**

Bulk Stock Style Hub Cap w/ Holes, Each



**NEW!**  
10-1055-B

**NEW!**  
10-1057-B

## CLASSIC 'NIPPLE' HUB CAPS

Chrome Classic 'Nipple' Hub Caps – available for both 4-Lug & 5-Lug stock VW Wheels. Drilled for your choice of Crests. Will also fit most Chrome aftermarket VW Wheels. [See page 287 for crests.](#)

**10-1055-B** **NEW!**

Bulk Classic 'Nipple' Hub Caps for 4-Lug VW Wheels, Ea

**10-1057-B** **NEW!**

Bulk Classic 'Nipple' Hub Caps for 5-Lug VW Wheels, Ea



# WHEELS & TIRES

## EMPI CLASSIC CRESTS FOR HUB CAPS

Your choice of 3 Classic Crest Designs...White with the Blue EMPI Logo, Black with the Wolf Logo and Chrome with the EMPI 3-Color Stallion Logo. Sold as Sets of 4 w/Retainers with hardware. Logo's are 61.40mm O.D. See page 286 for hub caps.

10-1077 **NEW!** EMPI Logo Crest, Set of 4 w/Retainers

10-1078 **NEW!** Wolf Crest, Set of 4 w/Retainers

10-1079 **NEW!** EMPI 3-Color Stallion Logo Crest, Set of 4 w/Retainers



## WHEEL CAP AND HORN BUTTON LOGOS

17-2991 **NEW!** EMPI/GT Logo, Blue, 36mm  
Fits Horn Button 79-4024/25/56/57/58, Set of 4

17-2995 **NEW!** EMPI Logo, 36mm  
Fits Horn Button 79-4024/25/56/57/58, Set of 4

17-2992 **NEW!** EMPI/GT Logo, White, 43mm  
Fits Most Wheels & Wheel Caps, Set of 4

17-2993 **NEW!** EMPI/GT Logo, Blue, 43mm  
Fits Most Wheels & Wheel Caps, Set of 4

9670 **NEW!** EMPI Logo, 43mm  
Fits Most Wheels & Wheel Caps, Set of 4  
Also fits 79-4115/16/17

9664 **NEW!** EMPI Logo, Black / Silver, 43mm  
Fits Most Wheels & Wheel Caps, Set of 4  
Also fits 79-4115/16/17

9671 **NEW!** GT Logo, 43mm  
Fits Most Wheels & Wheel Caps, Set of 4

9665 **NEW!** EMPI Logo, 37mm  
Fits 4 Spoke Wheel Cap 10-1092, 10-1093 and 10-1094, Set of 4

9666 **NEW!** EMPI Logo, 62mm  
Fits Wheel Cap for New Beetle 9736 and 9737, Set of 4

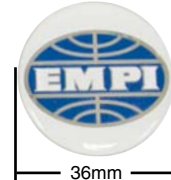
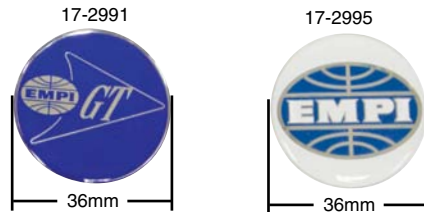

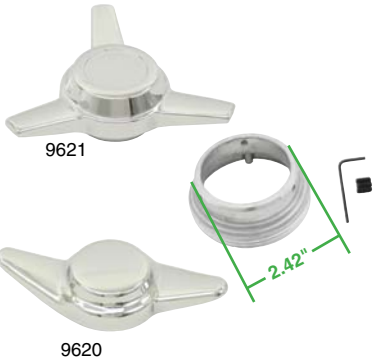

## CHROME WHEEL KNOCK OFFS

The original sports car look. Choose from 2 spoke sports car style or the 3 spoke spinner style. Both types fit most mag wheels and are available in show chrome or black high gloss powder coat finish. Includes all mounting hardware.

**9620** Chrome 2 Spoke Knock-Offs, Set of 4  
**10-9620** Black 2 Spoke Knock-Offs, Set of 4

**9621** Chrome 3 Spoke Knock-Offs, Set of 4  
**10-9621** Black 3 Spoke Knock-Offs, Set of 4



## EMPI WHEEL CENTER CAPS (OLD STYLE)

The finishing touch for your Old Style 8 Spoke & Riviera style wheels. Short caps can be used on Old Style 8 Spoke & Riviera style wheels. Short cap may not clear on I.D. of some particular applications.

**9567** Replacement Cap Only, Black, No Logo, Fits AE & RK  
**9674** Replacement Cap Only, Chrome w/ Logo, Fits AE Only



## STAINLESS STEEL BEAUTY RINGS

For a long lasting appearance stainless steel is the way to go. These 2 1/2" deep Beauty Rings are made to fit the O.E. steel wheels and are available in both 14" and 15" versions. Sold in a set of 4.

**10-1068** Stainless Steel Wheel Trim Rings, 14", Set of 4 (Boxed)  
**10-1069** Stainless Steel Wheel Trim Rings, 15", Set of 4 (Boxed)



## BEAUTY RINGS

Aluminum Beauty Rings add that finishing touch to your stock rims.

**9553** Beauty Rings, Early, 49-65, Set of 4 (Bagged)  
**9554** Beauty Rings, Early, 66-67, Set of 4 (Bagged)  
**9555** Beauty Rings, Late, 68-72, Set of 4 (Bagged)  
**9556** Beauty Rings, Late, 74-79, Set of 4 (Bagged)



## EMPI BILLET HUB CAP PULLERS/JACK HOLE COVER

An old idea with a modern twist. Made from Billet Aluminum 6061-T6, EMPI's Billet Aluminum Hub Cap Pullers offer a 21st century high tech version of an old favorite. Two spring steel wire fingers hook into the drain holes in the edge of the hub cap for easy removal while eliminating damage to the wheel or hub cap caused by using screw drivers to pry them off. Neatly store in the jack ports while not in use. Available with polished smooth finish or with a diecast EMPI globe logo for the ultimate stylish look (black).

**10-1075** EMPI Oval Hub Cap Puller - Smooth, Pair  
**10-1076** EMPI Oval Hub Cap Puller - w/EMPI Logo (Black), Pair

## VINTAGE STYLE HUB CAP PULLER/JACK HOLE COVER

EMPI also offers a reproduction of the original accessory hub cap pullers. Perfect for your stock restoration. Polished stainless cover on plastic body and plated wire just like the originals.

**10-1065** Vintage Style Hub Cap Puller, Pair  
**98-0113** O.E. Type Tool Kit Hubcap Puller, Each  
 (Bulk P/N: 251 012 243)

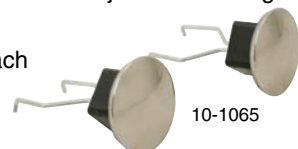





# WHEELS & TIRES

## TIRES

Dry & Wet Traction, Safety, Quiet Ride, Maneuverability and Reasonable Prices are the main factors in choosing tires for your ride. EMPI offers a variety of tires - incorporating all of these features - in all the popular sizes.

### IMPORTANT NOTE:

ALWAYS CHECK THE TIRE AND THE MANUFACTURER'S WEBSITE FOR THE LATEST LISTING FOR YOUR TIRE'S LOAD CAPACITY AND MAXIMUM AIR PRESSURE. LOAD AND TIRE CLEARANCE ARE CRITICAL TO YOUR SAFETY.

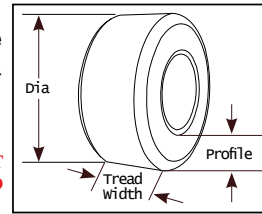

## NANKANG CX668

Computer-designed tread pattern to reduce hydroplaning and increase maneuverability on wet roads, while reducing noise and providing better comfort. 10-4020 and 10-4021 are M Speed Rated, up to 81mph. 10-4022 is N Speed Rated, up to 87mph.



Part #	Size	Load weight	Max PSI (CoId)	Diameter	Tread width	Profile	Tread	Side
10-4022	165/80-R15	1199lbs	44	25.25"	5.75"	4.75"	1 Polyester 2 Steel	1 Polyester
10-4020	135/SR15	803lbs	44	23.5"	4.5"	3.75"		
10-4021	145/SR15	906lbs	44	24"	4.75"	3.75"		

## FEDERAL FORMOZA FD1

Made from an advanced rubber compound, the Formoza FD1 has a long tread life, delivers a superior ride comfort and produces minimal noise for a quiet ride. Maximized wet and dry performance and steering response. V Speed Rating, up to 149mph.



Part #	Size	Load weight	Max PSI (CoId)	Diameter	Tread width	Profile	Tread	Side
10-4030	165/45-R15	695lbs	36	20.9"	6.6"	2"	1 Polyester 2 Steel	2 Polyester
10-4031	165/50-R15	804lbs	36	21.6"	6.7"	1 Nylon		

## FIRESTONE F560 SERIES **Firestone**

The Classic Cal-Look Tire....Perfect sizing options. Tread design and compound work well in wet or dry conditions. Poly/Steel Radial construction. DOT and ECE Approved. P Speed Rating, up to 93mph.



Part #	Size	Load weight	Max PSI (CoId)	Diameter	Tread width	Profile	Section width	Recommended Rim width
10-4032	125R15	695lbs	44	23"	3.75"	2"	5.0"	3.5" - 4.5"
10-4033	135R15	780lbs	44	23.57"	4.0"	2.5"	5.0"	3.5" - 4.5"
10-4034	155R15	1045lbs	44	24.8"	4.40"	2.5"	6.18"	4" - 5.5"

## INNER TUBE

For use with 125, 135, 145 and 3 Rib Tires.

**10-4015** Inner Tube with 16mm Valve Stem, Fits **Most** Standard Steel Wheels

**10-4016** Inner Tube with 12mm Valve Stem, Fits Most Aftermarket Wheels



## SAND BUGGY TIRES

Special 3-Rib design allows great turning control in sand while running smooth and straight. (Inner Tube Required).

**10-4010** 15" 3-Rib, Front +





**Right Hand Drive!**



## EMPI ALUMINUM T-HANDLE SHIFTERS

Get through the gears in style with our Precision Made, Polished Aluminum Shifter. Standard and short versions, both have Reverse Lock-out Button and "EMPI" cast into the handle. All shifters are supplied with reverse lock-out plate. A right hand drive version is now available!

- 4498 EMPI Polished Alum. T-Handle Shifter, Short, 10" O.A.L.
- 4499 EMPI Polished Alum. T-Handle Shifter, Standard, 12" O.A.L.

### RIGHT HAND DRIVE SHIFTER

- 4497 EMPI Polished Alum. T-Handle Shifter, RHD, Standard, 12" O.A.L.



## EMPI TRIGGER SHIFTERS

Popular Trigger Shifter features round Chrome shaft with sliding "Trigger" to release reverse lock-out. Available with short or long shaft and extra-long shaft for Bus applications, with "EMPI" cast into the trigger.

- 4450 EMPI Trigger Shifter, Long, All Bug & Ghia, 13 1/2" O.A.L.
- 4451 EMPI Trigger Shifter, Short, All Bug & Ghia, 12" O.A.L.
- 4449 EMPI Trigger Shifter, Extra Long, Bus, 60-79, 23 1/2" O.A.L.
- 4450-6 Bulk Plastic Boot Only
- 4450-5 Bulk Rubber Boot Only
- 4450-7 Bulk Black Knob Only



## BILLET KNOB FOR TRIGGER SHIFTERS

Round polished billet aluminum knob. Fits P/N: 4450, 4451 & 4449 Trigger Shifters. 3/8 - 24 threads.

- 79-5052 Billet Aluminum Shift Knob, Round



## SHIFTER LOCKS

The original Anti-Theft device...bolts-on in minutes and cannot be overridden or bypassed.

- 17-2949 Shift Lock, Type 1 to 67
- 17-2950 Shift Lock, Type 1 to 68-71
- 17-2952 Shift Lock, Type 2 to 73



## GEAR SHIFT BOOT

Durable black neoprene boot fits most aftermarket and stock shifters.

- 4535 Gear Shift Boot, Black



# CHASSIS COMPONENTS

## EMPI BILLET PLUS SHIFTERS

Fully machined from billet aluminum on the handle and base. Anodized and re-machined with highlights on the base. Then finished with an EMPI logo engraved into the top of the handle. This shifter stands out from all the others. The super strong chromed shaft and New Poly Resin Bushing makes this shifter not only a looker, but a super performer as well. Available in Left & Right-Hand Drive models. Comes with H.D. Lockout Plate. For Bug/Ghia and Bus/Transporter

**B560500** **NEW!** "BILLET PLUS" Performance Shifter, Type 1, LHD  
**B560400** **NEW!** "BILLET PLUS" Performance Shifter, Type 1, RHD

**B561800** **NEW!** "BILLET PLUS" Performance Shifter, Type 2, 60-65 LHD  
**B561900** **NEW!** "BILLET PLUS" Performance Shifter, Type 2, 60-65 RHD

**B560600** **NEW!** "BILLET PLUS" Performance Shifter, Type 2, 66-79 LHD  
**B561600** **NEW!** "BILLET PLUS" Performance Shifter, Type 2, 66-79 RHD



Stock shifters are pictured to show the difference



**NEW!**  
B560500



**NEW!**  
B560400



Engraved Logo



Base



**NEW!**  
B560600 / B561800



## H.D. BUGPACK REVERSE LOCKOUT PLATE

Re-designed with added support where needed to handle even the toughest of shifts, our new BUGPACK Reverse Lockout Plate easily replaces worn lockout plates. Fits all stock and push-button reverse lockout style shifters.

**B559550** **NEW!** H.D. BUGPACK Reverse Lockout Plate



**NEW!**





## STOCK STYLE SHIFTER & RELATED PARTS

Replace your stock shifter with a new shifter assembly or upgrade your worn out components.

- 98-1025** Stock Shifter Assy., Angled, Type 1, 56-67  
(Bulk P/N: 113 798 121) w/10mm Thread & Knob
- 98-7095** Stock Shifter Assy., Straight, Type 1, 68-on  
(Bulk P/N: 113 798 121A) w/12mm Thread & Knob
- 4456** Replacement Reverse Lock-Out Plate  
(Bulk P/N: 211 711 149)
- 98-2038** Shift Rod Bushing, Type 1, 60-79  
(Bulk P/N: 111 701 259A)
- 98-7096-B** Shift Bushing Repair Kit, All Bushings Necessary,  
Type 2 54-79, Vanagon 80-93  
(Ref. P/N: 211 798 200)
- 98-9981** Universal Gear Shifter Boot  
(Bulk P/N: 113 711 115A) Fits Stock Shifter Assemblies, Type 1 49-79, Type 2 60-71
- 98-7013-B** Locking Ring for P/N: 98-2038 Bushing, Bulk  
(Ref. P/N: 111 701 263)
- 98-7011-B** Shift Guide, Type 1, 60-79, Bulk  
(Ref. P/N: 111 701 255B)
- 98-7014** Shift Rod Bushing Rebuilding Kit (Skinpacked)  
(Incl. Bushing, Guide & Locking Ring)

## QUICK SHIFT KITS

Shorten the throw of your stock shifter up to 40% quickly, easily....and inexpensively. Includes bolts. Fits all Type 1 (Exc. Autostick).

- 4500** Quick Shift Kit, Cast Aluminum
- 4501** Quick Shift Kit, Hi-Tech Plastic

## URETHANE & STOCK SHIFT COUPLERS - EARLY STYLE

Urethane is the way to go for a shift coupler if you want to take sloppy play out of the equation. This early style coupler works for all Type 1 thru 64 along with other applications like off-road cars that use this style of shift linkage coupler. Supplied with new set-screws as well. Stock shift couplers also available.

- 16-5102** Urethane Shift Coupler, Early Style
- 98-1079** Early Shift Coupler  
(Bulk P/N: 111 711 175B)
- 98-1026-2** Grub Screw for Coupler, Each  
(Ref. P/N: 211 711 189A)

## URETHANE SHIFT COUPLER - LATE STYLE

Much like the original one it replaces, this fits Type 1 65-on and other applications that use this style of coupler. The key improvement on this unit is the two inserts for the cage have been made out of urethane so the shifter linkage will be much tighter and responsive. This is a must do upgrade for almost every car out there that uses this style of shift coupler.

- 16-5103** Shift Coupler, w/Urethane Inserts, Type 1 65-79,  
Ghia 65-74, Type 2 68-79, Type 3 All  
(Ref. P/N: 311 798 211)

**Heavy Gage Steel Cage with heavy duty bolt and Urethane Inserts make this H.D. Coupler the one to use for any performance application.**

- 16-5105** H.D. Shift Coupler w/Urethane Inserts & Hardware.,  
Type 1 65-79, Ghia 65-74, Type 2 68-79, Type 3 All

## URETHANE SHIFT CAGE INSERTS

Urethane Inserts Only for 16-5103 and 16-5105 Shift Couplers.

- 16-5104**  Urethane Inserts Only for 16-5103 and 16-5105 Shift Couplers,  
Pair



# CHASSIS COMPONENTS

## EMERGENCY BRAKE HANDLE KIT

Replace your stock handle with show quality Chrome or black. Complete assembly for easy installation. Fits all Type 1, 56-79.

- 4548** Black Emergency Brake Handle Kit  
(Bulk P/N: 113 798 305)
- 4549** Chrome Emergency Brake Handle Kit  
(Bulk P/N: 113 798 305CH)
- 4547** Hardware Kit for E-Brake Handle (All Parts Less Handle)
- 98-6118-B** Anchor Pin, Parking Brake Lever (use w/211 609 619),  
Type 1 50-79, Ghia 56-74, Type 2 55-79, Type 3 64-73, Each
- (Ref. P/N: 211 609 601B)
- 98-6121-B** C Clip, Parking Brake Lever Pin, Type 1 50-79, Ghia 56-74,  
Type 2 55-79, Type 3 64-73, Each
- (Ref. P/N: 211 609 619)



## BILLET PARKING BRAKE COVER

The finishing touch to any custom or stock interior. Installs over stock E-brake handle and is held in place with set screws. Fits all VW models including Water Cooled.

- 11-4542** Billet Aluminum Parking Brake Cover

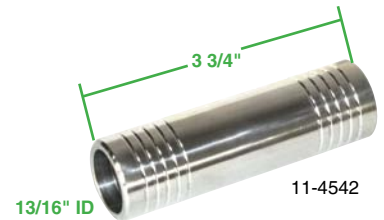

## EMERGENCY BRAKE BOOTS

Made from durable material and are available in a variety of colors. Complete your interior with the correct emergency brake boot.

- 9954** E-Brake Boot, Black, Type 1 55-57  
(Bulk P/N: 111 863 341A)
- 9952** Emergency Brake Boot, Black, Type 1 58 thru 64, Type 3 thru 65  
(Bulk P/N: 311 863 341A)



## TYPE 1 65-ON & S/B - TYPE 3 66-ON

- 4483** Emergency Brake Boot, Black, Type 1 65-on & S/B, Type 3 66-on  
(Bulk P/N: 311 711 461)
- 4484** Emergency Brake Boot, White
- 8634** Emergency Brake Boot, Neon Pink



## EMERGENCY BRAKE BOOT, TYPE 2, 50-79

A great reproduction of this hard to find boot and in your choice of Black or Grey. Fits Bus & Transporter from 50 to 79.

- 9958** NEW! Brake Boot, Grey, T-2, 50-79, Each  
(Bulk P/N: 211 863 341)
- 9959** NEW! Brake Boot, Blk, T-2, 50-79, Each  
(Bulk P/N: 211 863 341B)





## STOCK REPLACEMENT PEDAL ASSEMBLY

Complete pedal assembly. Can be used for 58-64 as a retro-fit using P/N: 98-1027 or 17-2964 Accelerator Kit with pedal.

**4526-B** Stock Pedal Assy., Type 1, 65-72  
(Ref. P/N: 113 798 900)

**98-7077-B** Clutch Pedal Shaft, Type 1 65-71, Ghia 65-71, Type 3 65-71  
(Ref. P/N: 113 721 305B)

**98-7075-B** Clutch Pedal Shaft, Type 1, 72-79 (Original German Style)  
(Ref. P/N: 111 721 305B)

**98-7067-B** Return Spring, Brake Pedal, Type 2 55-67, Each  
(Ref. P/N: 211 721 163A)

**98-7074-B** Brake Pedal Stop Plate, Type 1 50-79, Ghia 58-74, Type 3 64-73, Each  
(Ref. P/N: 113 721 231E)

Zerk Fitting - Lubricates both clutch and brake shafts for smooth operation



.570" stock-size throttle shaft

Machined groove for maximum lubrication

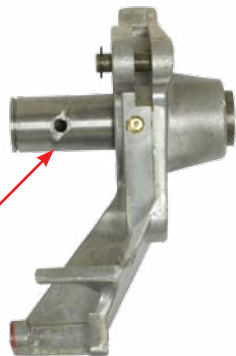

98-7077-B



98-7074-B



98-7075-B



98-7067-B



## ACCELERATOR REPAIR KIT

Stock replacement accelerator pedal and attaching hardware. Fits Type 1, 67-79.

**98-1027** Accelerator Repair Kit w/Pedal  
(Bulk P/N: 113 798 507B)

**98-7090-B** Accelerator Repair Kit only, Type 1 67-79, Ghia 66-74, Type 3 64-73  
(Ref P/N: 113 798 074)

**98-7088-B** Accelerator Repair Kit only, Type 1 58-66, Ghia 58-66  
(Ref P/N: 113 798 078)

## CUSTOM PEDAL COVERS

The finishing touch to any interior. Our custom pedal covers are chrome with rubber foot contact inserts. Fits all Type 1, Type 2, 55-67, All Type 3.



**4550** Pedal Covers, Brake & Clutch, Pair

**4551** Pedal Covers, Brake, Clutch & Accel., 3-Piece Set

**4552** Pedal Cover, Accelerator, Each



# CHASSIS COMPONENTS

## STOCK STYLE PEDAL PADS

Replace your worn pads with these quality rubber pads. Easy to install. Our Pedal pad kit includes the clutch, brake and accelerator pads. Fits all Type 1, Type 2 55-67, all Type 3.

- 98-1068** Pedal Pad Kit, 3-Piece Set
- 9904** Pedal Pads, Clutch/Brake, Pair  
(Bulk P/N: 311 721 173A, Each)
- 98-1072** Pedal Pad, Accelerator, Each  
(Bulk P/N: 113 721 647A)



## EMPI BILLET ALUMINUM THROTTLE PEDAL

Made from Polished Billet Aluminum and featuring a Diamond-Design rubber insert with the EMPI Logo for miles of easy cruising. Easy installation on 65-72 pedal assemblies. Also fits EMPI P/N 4526-B.

- 17-2994** **NEW!** EMPI Polished Billet Aluminum Throttle Pedal, Type 1, 65-72, Type 3, 65-71, Each  
Also fits EMPI P/N 4526-B.



## PEDAL PADS W/ EMPI LOGO

Now you can replace your worn Pedal Pads with our new Diamond Design Pattern featuring the EMPI Logo. A perfect match for our New Billet Aluminum Throttle Pedal (P/N: 17-2994). Made from quality rubber for miles of driving. Fits stock pedals. Fits all Type 1, Type 2 55-67, all Type 3.

- 17-2996** **NEW!** Pedal Pads Clutch / Brake, w/ EMPI Logo, Pair



## EMPI ROLLER PEDALS

Roller Pedals not only look trick, they make for smoother acceleration...especially on rough roads and freeways. A must for off-road. Choose from available colors or Billet. Fits all Type 1.

- 3160** Roller Pedal, Black
- 8628** Roller Pedal, Neon Pink
- 8511** Roller Pedal, Billet Aluminum Roller





## H.D. THROTTLE CABLE KIT

H.D. throttle cable puts an end to cable failure. Includes plastic tubing for Buggies or Sedans with rusted throttle tubes. Cable kit includes 9-foot heavy duty cable, tubing and clamps.

- 4860 H.D. Throttle Cable Kit
- 4861 H.D. Throttle Cable Kit, w/Roller Pedal



- 4860-7 H.D. Throttle Cable Only, 9' Long (Skin Packed)
- 4860-6 **NEW!** Bulk H.D. Throttle Cable Only, 9' Long



- 4862-7 H.D. Throttle Cable Only, 16' Long (Skin Packed)
- 4862-6 **NEW!** Bulk H.D. Throttle Cable Only, 16' Long



## RACING THROTTLE CABLE

Super heavy duty stainless steel 1/8" throttle cable is virtually indestructible. Comes in a 11' length to satisfy most custom installations.

- B551010 **NEW!** Racing Throttle Cable 11'

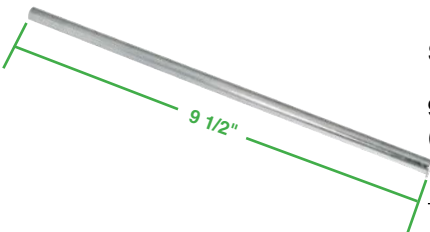

## THROTTLE CABLE TUBE

Stock throttle tube passes through fan housing protecting cable from wear and breakage.

- 98-1002 Stock Throttle Cable Tube  
(Bulk P/N: 043 129 893)

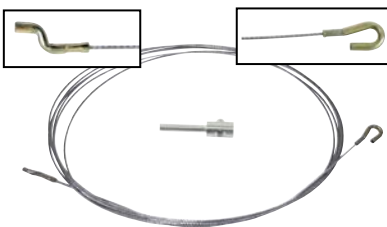

## UNIVERSAL THROTTLE CABLE KIT

Small diameter cable fits thru stock cable tube. Features stock "Dog Leg" on one end and Loop on other. Choose your application...cut off the other. Includes cable adapter. The 15' cable is long enough for most applications.

- 4863 Universal Throttle Cable Kit



## CABLE SHORTENING KITS

Shorten your clutch, emergency brake and throttle cables quickly and easily. A must for buggies with shortened pans.

- 3167 Complete Cable Shortening Kit, Includes P/N: 3168, 3169 & 3170
- 3168 Cable Shortening Kit, Clutch Only
- 3169 Cable Shortening Kit, Emergency Brake Only
- 3170 Cable Shortening Kit, Throttle Only (Fits on cable only)



- 3171 Throttle Cable Extending Kit, 2 pcs. (Fits on cable end or cable)
- 3171-7 Round PC only for Throttle Cable Extending Kit, Each  
(Ref. P/N: 311 129 777)





# CHASSIS COMPONENTS

## STOCK CABLES

EMPI stocks a full line of Accelerator, Clutch, Parking Brake, Heater and Speedometer Cables.

### ACCELERATOR CABLES

111 721 555C	98-7500-B	Acc. Cable, Type 1, 58-65
111 721 555E	98-7501-B	Acc. Cable, Type 1, 66-71
111 721 555J	98-7502-B	Acc. Cable, Type 1, 72-74
113 721 551	98-7083-B	Bowden Tube, Type 1, 56-79, Ghia 56-74



111 721 555C

### CLUTCH CABLES

111 721 335	98-7200-B	Clutch Cable, Type 1, thru 60, 62-63
113 721 335A	98-7203-B	Clutch Cable, Type 1, 6/63-71
111 721 335C	98-7201-B	Clutch Cable, Type 1, 72-74
211 721 335J	98-7205-B	Clutch Cable, Type 2, 72-79
311 721 361	98-7208-B	Bowden Tube, Type 1, thru 79, Type 2, thru 67, Type 3, All
131 721 349	98-7012-B	Bulk 7mm Wing Nut for Clutch Adjustment, Each
	98-7012-0	Skin-Packed 7mm Wing Nut for Clutch Adjustment, Each



113 721 335A



311 721 361

### HEATER CABLES

111 711 713A	98-7056-B	Heater Cable, Rear Footwell, Type1, 73-79
211 711 629B	98-7033-B	Heater Cable, Type 2, 55-67
211 711 630L	98-7038-B	Heater Cable, Right, Type 2, 1972
211 711 630N	98-7039-B	Heater Cable, Right, Type 2, 73-79



113 721 551



98-7012-B

### EMERGENCY BRAKE CABLES

113 609 721F	98-6900-B	Emergency Brake Cable, Type 1, 58-64, Each
113 609 721L	98-6901-B	Emergency Brake Cable, Type 1, 65-67, Each
113 609 721J	98-6902-B	Emergency Brake Cable, Type 1, 68-72, Each
133 609 721	98-6903-B	Emergency Brake Cable, Type 1, 73-on, Each



113 609 721F

### SPEEDOMETER CABLES

111 957 801J	98-9801-B	Speedo. Cable, Type 1, 58-65
111 957 801K	98-9802-B	Speedo. Cable, Type 1, 66-74
113 957 801A	98-9803-B	Speedo. Cable, S/B, 71-74
211 957 801E	98-9804-B	Speedo. Cable, Type 2, thru 67



111 957 801J

## DUST BOOT

98-9809-B Dust Boot, Speedometer Cable, Type 1 61-77, Ghia 56-74, Each (Ref. P/N: 111 957 861)



## ELECTRIC SPEEDO TO CABLE CONVERSION KIT

This kit allows you to hook up an electronic speedometer into a Type 1 sedan without modifying your drums or rotors. The custom designed cable utilizes the O.E.M. dust cap hole with an inductive sensor on the opposite end, which can be easily wired to your electronic speedometer.

16-9290 Electric Speedo to Cable Conversion Kit



## STOCK-STYLE BUMPERS

Give your VW a new smile with our stock style bumpers. Early (67 and earlier) are complete with bows and guards. Available for all Type 1.



98-1023-B

**98-1023-B** Stock Bumper Assembly, Front 55-67  
(Ref. P/N: 113 798 053A) **Shipped by Truck Only.**



98-1024-B

**98-1024-B** Stock Bumper Assembly, Rear 55-67  
(Ref. P/N: 113 798 073B) **Shipped by Truck Only.**



98-1006-B

**98-1006-B** Stock Bumper, Front, 68-73  
(Ref. P/N: 113 707 103D) **Shipped by Truck Only.**



98-1017-B

**98-1017-B** Stock Bumper, Rear, 68-73  
(Ref. P/N: 113 707 303C) **Shipped by Truck Only.**

## CAL-LOOK BUMPERS

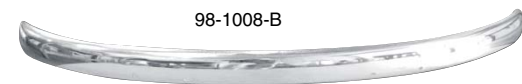

98-1008-B

**98-1008-B** Blade w/4 Holes for Brackets Only, Front, thru 67  
(Ref. P/N: 113 707 111A) **Shipped by Truck Only.**



98-1018-B

**98-1018-B** Blade w/4 Holes for Brackets Only, Rear, thru 67  
(Ref. P/N: 113 707 311A) **Shipped by Truck Only.**



98-1007-B

**98-1007-B** Bumper, w/Turn Signal Cut-outs, Front, 68-73  
(Ref. P/N: 113 707 103DM)(**Note: P/N: 98-1005 Brackets Required**)  
**Shipped by Truck Only.**



3173-B



98-1005

**3173** Euro Bumper Guard, Front & Rear, thru 67, Pair  
**3173-B** Bulk Euro Bumper Guard, Front & Rear, thru 67, Each  
(Ref. P/N: 111 707 155)

**98-1071** Turn Signal Assy. 3-Wire for P/N: 98-1007-B, Each  
(Bulk P/N: 113 953 049AK)

**98-1005** Bracket for P/N: 98-1007-B Bumper, Pair  
(Bulk P/N: 111 807 115, Each)



# CHASSIS COMPONENTS

## SHOW CHROME HIGH QUALITY BUMPERS

All new Show Chrome Bumpers are a step up from all previous bumpers offered. Finished as if you sent them to a local chrome shop, these bumpers are plated and polished to a Show Chrome Finish.

**98-1114-B** **NEW!** Bumper Assembly, Front 55-67  
**Shipped by Truck Only.**

**98-1115-B** **NEW!** Bumper Assembly, Rear 55-67  
**Shipped by Truck Only.**

**98-1110-B** **NEW!** Bumper Blade, Front 68-73  
**Shipped by Truck Only.**

**98-1111-B** **NEW!** Bumper Blade, Rear 68-73  
**Shipped by Truck Only.**

**98-1112-B** **NEW!** Euro Bumper Blade, w/ 4 Holes for Brackets, Front, thru 67  
**Shipped by Truck Only.**

**98-1113-B** **NEW!** Euro Bumper Blade, w/ 4 Holes for Brackets, Rear, thru 67  
**Shipped by Truck Only.**



## CHROME BUMPER GUARDS

Add protection and great looks with these Chrome Bumper Guards. Fits both Front or Rear and come skinpacked in pairs for bumpers with or without impact strip.

**98-0750** **NEW!** Chrome Bumper Guards  
Front or Rear, Left or Right for bumpers with Impact Strip,  
Bug, S/B 68-73, Pair

**98-0751** **NEW!** Chrome Bumper Guards  
Front or Rear, Left or Right for bumpers  
without Impact Strip, Bug, S/B 68-73, Pair



Notched for Rubber Strip

**NEW!**  
98-0750



98-0751 **NEW!**

## BUMPER OVER RIDERS

These reproductions of the vintage bumper over riders feature a **stainless steel** blade. All other components and support are plated. The bumper over rider bolts to the front or rear of your existing bumper with included hardware. They can be used with blade or factory over-rider front bumpers. For Type 1, thru 1967.

**16-9801** **NEW!** **Stainless Steel** Front Over Rider Set, Type 1, thru 67

**16-9802** **NEW!** **Stainless Steel** Rear Over Rider Set, Type 1, thru 67

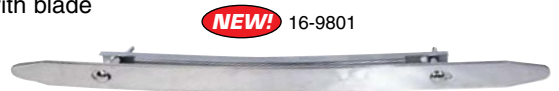

**NEW!** 16-9801



**NEW!** 16-9802

## "T" BARS / TUBE BUMPERS

The original "Cal-Look" T-Bars. Choose from T-Bars in chrome, black or polished aluminum. Tube nerf bars in chrome.

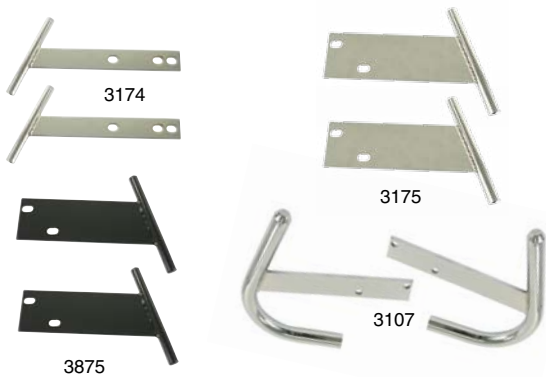

- 3174** "T" Bars, Chrome, thru 67, Pair
- 3175** "T" Bars, Chrome, 68-73, Pair
- 3874** "T" Bars, Black, thru 67, Pair
- 3875** "T" Bars, Black, 68-73, Pair
- 3107** Chrome Tube Nerf Bar, 68-73, Pair (Boxed)

## POLISHED ALUMINUM "T" BARS



- 3876** Polished Alum. "T" Bars, Type 1, thru 67, Pair
- 3877** Polished Alum. "T" Bars, Type 1, 68-73, Pair

## BUMPER BRACKETS & SUPPORTS



- 98-1016** Support Tube Black, Front, 55-67, Pair (Bulk P/N: 113 707 233/4, Each)
- 98-1022** Support Tube, Rear, Black, 55-67, Pair (Bulk P/N: 113 707 391/2, Each)
- 98-1078** Reinforcement, Black, 55-67, Pair (Bulk P/N: 111 707 121, Each)
- 98-1009** Bracket, Front Left, Black, 68-73, Each (Bulk P/N: 113 707 133A)
- 98-1010** Bracket, Front Right, Black, 68-73, Each (Bulk P/N: 113 707 134A)
- 98-1019** Bracket, Rear Left, Black, 68-73, Each (Bulk P/N: 113 707 333A)
- 98-1020** Bracket, Rear Right, Black, 68-73, Each (Bulk P/N: 113 707 334A)

## EMPI HEAVY DUTY BUMPER BRACKETS

Original quality, heavy duty bumper brackets powder coated black.



- 98-1011** Bracket, Front Black, 55-67, Pair (Bulk P/N: 111 707 135A/6A, Each)
- 98-1021** Bracket, Rear, Black, 55-67, Pair (Bulk P/N: 111 707 335B/6B, Each)



# CHASSIS COMPONENTS

## CHROME BUMPER BOLTS

- 98-1013 Bolt, Long, thru 67, Set of 4
- 98-1013-7 Bulk Bolt, Long, 100 pcs.
- 98-1013-B Bulk Bolt, Long, 12 pcs.  
(Ref. P/N: 113 707 191B)
- 98-1014 Bolt, Short, 68-73, Set of 4
- 98-1014-7 Bulk Bolt, Short, 68-73, 100 pcs.
- 98-1014-B Bulk Bolt, Short, 68-73, 12 pcs.  
(Ref. P/N: 113 707 191C)



98-1013-B

## BUMPER CONVERSION BRACKETS

Now there is a way to install early blade style bumpers onto a 68-73 Beetle! These conversion brackets bolt directly onto 68-73 Beetles and exit out of the stock fender/bracket hole. These do not fit Super Beetles. Due to their size and design, being made to an early bracket dimension at the fender, they allow for installing early fenders on your car at the same time. Finished with a nice satin black powdercoat these brackets help make for a great resto-custom upgrade. Mounting holes are slotted to accomodate most manufacturer's bumpers.

- 15-2045 Brackets, Type 1, 68-73, to Early Bumper, Front, Pair
- 15-2046 Brackets, Type 1, 68-73, to Early Bumper, Rear, Pair



## BUMPER SEALS & GROMMETS

Quality bumper bracket seals and over-rider grommets.

- 3178 Bumper Grommet, thru 67, Pair  
(Bulk P/N: 111 707 197A, Each)
- 3179 Bumper Grommet, 68-73 (Exc. 71-73 Super Front), Pair  
(Bulk P/N: 111 707 197B, Each)
- 98-1015 Over-rider Grommet, 55-67, Set of 4  
(Bulk P/N: 111 707 199A, Each)
- 16-9526 Over-rider Plug Kit, 4 pcs



## TYPE I 3" BODY LIFT KIT

Steel channel construction. Hardware included.

- 16-9800 3" Body Lift Kit, Type I, Kit (Boxed)  
**Shipped By Truck Only**



## ORIGIN PLATES

Get the vintage "Euro" look with our Origin Plates. These plates were common in Europe to show other motorists where you were from; different letters designated the various countries. Available with the letter "D", for Deutschland (Germany) or the EMPI globe logo. The stainless steel bracket easily attaches to the rear bumper bracket of pre 1967 sedans and convertibles. Each plate comes with bracket and necessary hardware.



- |         |  |
|---------|--|
| 15-2040 | "EMPI" Origin Plate w/Bracket                              |
| 15-2041 | "D" Origin Plate w/Bracket                                 |
| 15-2042 | Stainless Steel Bracket Only for Origin Plate (w/Hardware) |

## LICENSE PLATE BRACKETS

Stock-style brackets bolt front license plate to bumper and rear to deck lid. Zinc plated. Fits Type 1, 2, 3 & 4. Original design was for 68-79 T-1.

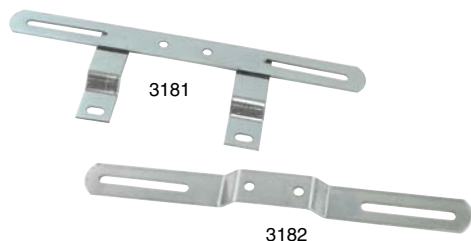

- |        |                                   |
|--------|-----------------------------------|
| 3181   | License Bracket, Front, Each      |
| 3181-B | Bulk License Bracket, Front, Each |
| 3182   | License Bracket, Rear, Each       |
| 3182-B | Bulk License Bracket, Rear, Each  |

## CHROME LICENSE PLATE LIGHT

Chrome plated heavy gauge steel with built-in license light. Great for Baja Bugs and Buggies. Comes with 12-Volt Bulb. **(Note: When installed on Fiberglass be sure to ground to chassis)**



- |      |                                      |
|------|--------------------------------------|
| 9457 | Chrome License Plate Light w/Bracket |
|------|--------------------------------------|

## ALUMINUM LIGHTED LICENSE FRAME

Aluminum with built-in license light to smooth-out your engine lid.

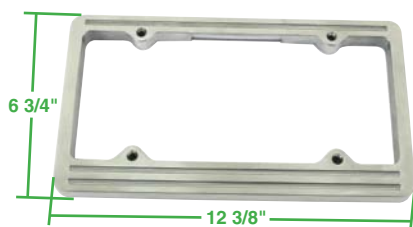

- |      |                                      |
|------|--------------------------------------|
| 8515 | Aluminum Lighted License Frame, Each |
|------|--------------------------------------|

## LICENSE PLATE FRAMES

Chrome steel license plate frames for front and rear plates.



- |         |                                   |
|---------|-----------------------------------|
| 15-2050 | License Plate Frame, Chrome, Each |
|---------|-----------------------------------|

## EMPI LICENSE PLATE FRAME

License plate frame with EMPI logo.



- |      |   |
|------|---|
| 6461 | EMPI USA License Plate Frame, Front, Each |
| 6460 | EMPI USA License Plate Frame, Rear, Each  |



# CHASSIS COMPONENTS

## H.D. STOCK REPLACEMENT RUNNING BOARDS

High quality heavy duty replacement running boards come complete with black vinyl mat and 16mm moldings. Fits all Type 1 Bug & Super Beetle. Sold in pairs only.

**6831-B** H.D. Running Boards, Pair  
(Ref: P/N: 113 821 509MHD)  
(113 898 509B + 113 898 510B)



6831-B

## BILLET LOOK RUNNING BOARDS

EMPI's high quality extruded aluminum running boards add that great custom look to any Beetle. Made from THICK extruded aluminum for extra strength. They never rust and with the black powder coat finish they will keep their good looks for years. Available in four popular versions... Fully polished for that full custom effect, Black High Gloss with Polished Ribs and Black Satin with Polished Edge (vintage style). All are supplied with necessary mounting hardware. Fits all Type 1 & S/B.



- 15-3001** Billet Look Running Brd., Fully Polished, Pr.
- 15-3002** Billet Look Running Brd., Gloss Black/Polished Ribs, Pr.
- 15-3003** Billet Look Running Brd., Black Satin, Polished Edge, Vintage Style, Pr.
- 15-3005** Billet Look Running Brd., Gloss Black, Polished Ribs, Polished Edge, pr.

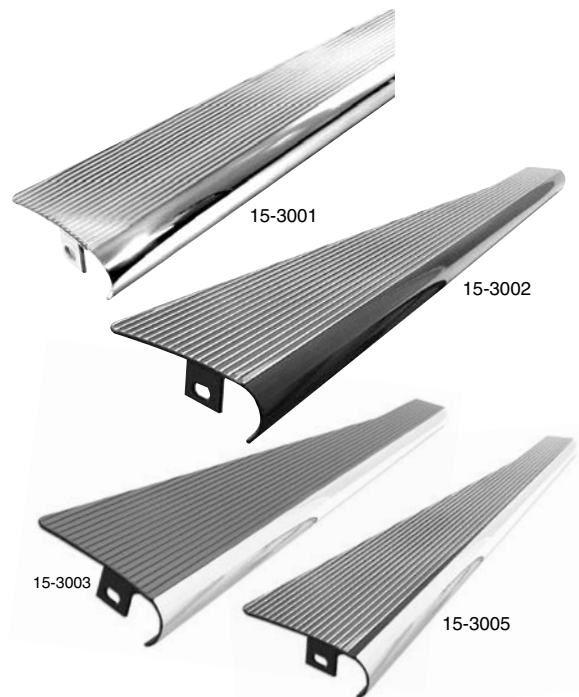

15-3001

15-3002

15-3003

15-3005

## STAINLESS STEEL RUNNING BOARDS

Show quality polished Stainless Steel. Available louvered or smooth. Includes hardware. Fits all Type 1 Bug & Super Beetle. Bulk Running Boards are sold in 5-Packs only. (Priced per pair)

**6820** **6820-9** Stainless Steel Running Boards, Louvered, Pair  
Bulk Stainless Steel Louvered Running Brd.  
(Must buy Multiples of 5)  +

**6822** **6822-9** Stainless Steel Running Boards, Smooth, Pair  
Bulk Stainless Steel Smooth Running Brd.  
(Must buy Multiples of 5)  +

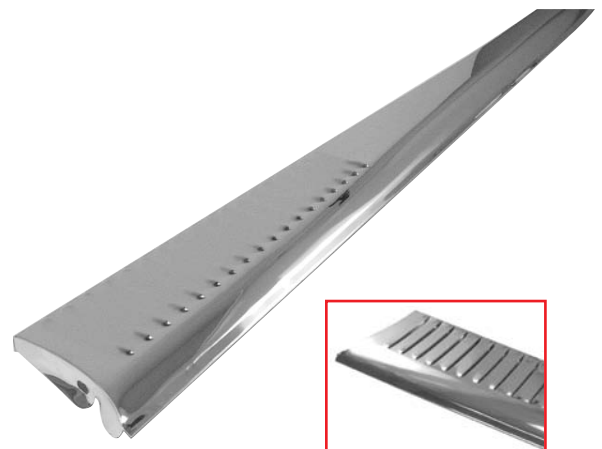

## EMPI BILLET LOOK RUNNING BOARDS

EMPI's high quality extruded aluminum running boards add that great custom look to any Beetle. Made from THICK extruded aluminum for extra strength. They never rust and with the black powder coat finish they will keep their good looks for years. Available in four popular versions... Fully polished for that full custom effect, Black High Gloss with Polished Ribs and Black Satin with Polished Edge (vintage style). All are supplied with necessary mounting hardware. Fits all Type 1 & S/B.

- 15-3016 **NEW!** Billet Look Running Brd., Fully Polished, Pr.
- 15-3017 **NEW!** Billet Look Running Brd., Gloss Black/Polished Ribs, Pr.
- 15-3018 **NEW!** Billet Look Running Brd., Black Satin, Polished Edge, Vintage Style, Pr.
- 15-3019 **NEW!** Billet Look Running Brd., Gloss Black, Polished Ribs, Polished Edge, pr.

**NEW!**  
15-3016



**NEW!**  
15-3017



**NEW!**  
15-3018



**NEW!**  
15-3019



**NEW!** 15-3016  
FULLY POLISHED



**NEW!** 15-3017  
GLOSS BLACK  
W/ POLISHED RIBS



**NEW!** 15-3018  
BLACK SATIN  
W/ POLISHED EDGE



**NEW!** 15-3019  
GLOSS BLACK  
W/ POLISHED RIBS  
AND EDGE





# EXTERIOR ACCESSORIES

## ***CAL-LOOK WINDOW RUBBER***

High quality window rubber made **without** molding groove for that smooth Cal-Look. And for that special contrast finish, choose White Rubber.

### **CAL-LOOK KITS**

- 3586** Rubber Kit, Type 1, 58-64, 4-Piece Set
- 3587** Rubber Kit, Type 1, 65-71 & 71 S/B, 4-Piece Set
- 3589** Rubber Kit, Type 1, 73-77 S/B, 4-Piece Set
- 3599** Rubber Kit, Type 1, 72-77 STD & 72 S/B, 4-Piece Set
- 3596** Rubber Kit, Type 3, Squareback, 4-Piece Set

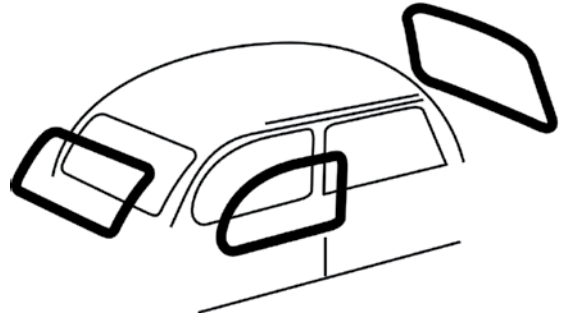

### **INDIVIDUAL CAL-LOOK SEALS**

Available for Type 1 only. Black only.

- 3569** Quarter Window Rubber, 65-77, Pair
- 3572** Windshield Rubber, thru 57
- 3574** Windshield Rubber, 65-77, 71-72 S/B
- 3577** Rear Window Rubber, 58-64
- 3578** Rear Window Rubber, 65-71
- 3579** Rear Window Rubber, 72-77 All



### **WHITE CAL-LOOK RUBBER KITS**

For that special contrast finish. Sold in 4-Piece Sets Only.

- 3545** Rubber Kit, Type 1, 53-57, 4-Piece Set
- 3548** Rubber Kit, Type 1, 73-77 S/B, 4-Piece Set

## ***STOCK WINDOW RUBBER***

Bring Back the factory appearance of your Bug with New Window Rubber.

### **STOCK WINDOW RUBBER KITS - WITH MOLDING GROOVE**

- 98-4542-B** Stock Window Rubber w/Groove Kit, 58-64, 4-Piece Set
- 98-4543-B** Stock Window Rubber w/Groove Kit, 65-71, 4-Piece Set
- 98-4544-B** Stock Window Rubber w/Groove Kit, 72-77, 4-Piece Set
- 98-4545-B** Stock Window Rubber w/Groove Kit, 73-77 S/B, 4-Piece Set



### **WINDSHIELD SEALS TYPE 1 SEDAN - WITH MOLDING GROOVE**

- 113 845 121J**    **98-4531-B**    65-77, Super Beetle 71-72

### **REAR WINDOW SEALS TYPE 1 SEDAN - WITH MOLDING GROOVE**

- 113 845 521J**    **98-4554-B**    65-71

### **QUARTER WINDOW SEALS TYPE 1 SEDAN - WITH MOLDING GROOVE**

- 113 845 321D**    **98-4535-B**    Left or Right, 65-77  
w/Fixed Quarter Windows, Each
- 113 847 135A**    **98-4714-B**    Left or Right, 65-77  
w/Pop-out Quarter Windows, Each

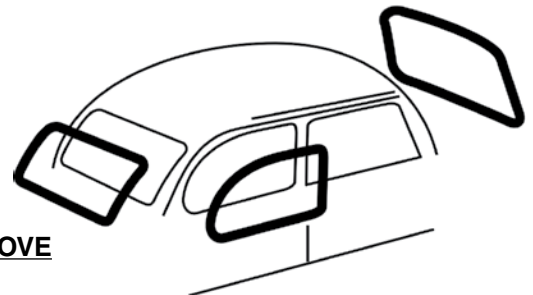



## **DOOR SEALS**

Stock replacement door seals keep the heat in and the water, wind and noise out!  
For Type 1 Sedans and Type 2.

**3593** Door Seals, Type 1, 56-66, Pair  
(Bulk P/N: 111 831 721A/2A, Pair)

**3594** Door Seals, Type 1, 67-on, Pair  
(Bulk P/N: 111 831 721D/2D, Pair)

**3597** Door Seals, Type 2, 68 & Later, Pair  
(Bulk P/N: 211 831 721D/2D, Pair)



## **VENT WINDOW SEALS**

Stock replacement vent window rubber for Type 1 Sedans.

**98-1086** Vent Wing Seal, Left, Type 1, 52-64  
(Bulk P/N: 111 837 625)

**98-1087** Vent Wing Seal, Right, Type 1, 52-64  
(Bulk P/N: 111 837 626)

**98-2007** Vent Wing Seal, Left, Type 1, 65-on  
(Bulk P/N: 111 837 625B)

**98-2008** Vent Wing Seal, Right, Type 1, 65-on  
(Bulk P/N: 111 837 626B)

**241 837 465** **98-3730-B** Vent Window Post Seal Left & Right, Type 1,  
65-on, Each



## **REPLACEMENT FELT WINDOW CHANNELS**

Replace that worn and fraying felt channel with EMPI's felt window channels.

**98-2089-B** Vent Wing Post Channel, 10mm, 52-64  
(Ref. P/N: 311 837 433)

**98-2090-B** Vent Wing Post Channel, 12mm, 65-on  
(Ref. P/N: 311 837 433A)

**9771-B** Top/Rear Channel, All Sedans, Pair  
(Ref. P/N: 111 837 439D, Pair) (72" Long, for Stock & 1-Piece Window Applications)



# EXTERIOR ACCESSORIES

## REPL. TRIM FRAMES & WINDOW SCRAPERS

Stock style replacement window scrapers. The outside scrapers are complete with bright aluminum molding. Applications for all Type 1 & Super Beetle sedans.

### OUTSIDE TRIM FRAMES

**98-1047-B** Left Outer Scraper, 52-64 (Ref. P/N: 113 853 321A)

**98-1049-B** Right Outer Scraper, 52-64 (Ref. P/N: 113 853 322A)

**98-1048-B** Left Outer Scraper, 65-on (Ref. P/N: 113 853 321D)

**98-1050-B** Right Outer Scraper, 65-on (Ref. P/N: 113 853 322D)



98-1050-B

### INSIDE SCRAPERS

**111 837 475** **98-1085-B** Left/Right Inner Scraper, 52-64, Each

**111 837 475A** **98-2061-B** Left Inner Scraper, 7 Clips, 65-68  
**111 837 476A** **98-2062-B** Right Inner Scraper, 7 Clips, 65-68

**111 837 475B** **98-2063-B** Left Inner Scraper, 4 Clips, 69-on  
**111 837 476B** **98-2064-B** Right Inner Scraper, 4 Clips, 69-on



111 837 475



111 837 475B

## WINDOW REGULATORS

New and improved replacement Window Regulators for 65-67 Type 1 Sedan stock applications and converting 58-64 and 68-77 Type 1 Sedans to one piece windows. **Splined Shaft is machined to accept early (Pinned) and late model (Screw) window cranks.** (See hard parts listing in the back of the catalog for more stock applications)

**9757** Window Regulator, Type 1, 65-67, Left + (Bulk P/N: 111 837 501F)

**9758** Window Regulator, Type 1, 65-67, Right + (Bulk P/N: 111 837 502F)

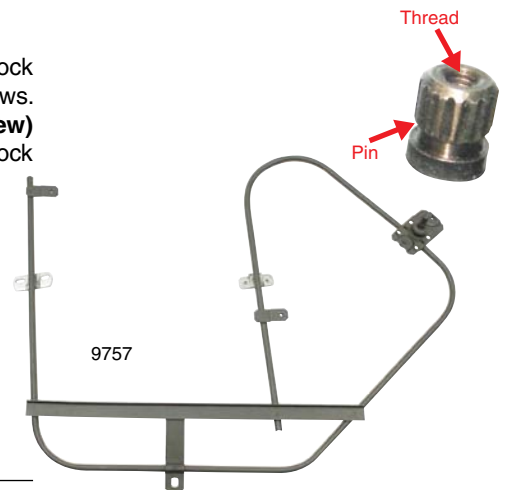

9757

## WINDOW SASHES

Window sashes attach the glass to the regulators and must be used when converting to a one piece window on 58-64 and 68-77 cars.

**9759** Window Sash, Pair





## ONE PIECE WINDOW KITS

Eliminate your vent windows for that smooth Cal-Look. Kits feature clear fully tempered glass, felt window channels, inner and outer scrapers and detailed installation instructions. Choose original Glue-in or easy Snap-in Kits. All applications require the use of P/N 9756 Door Stops.



### ONE PIECE WINDOW KITS W/GLUE-IN SCRAPERS

- 9760\* 1 Piece Window Kit, 58-64
- 9763\* 1 Piece Window Kit, 65 & Later
- 9770 Replacement Window Scrapers, Pack of 4
- 9771-B Replacement Window Channel, Pair  
(Ref. P/N: 111 837 439D, Pair) (72" Long, for Stock & 1-Piece Applications)



### ONE PIECE WINDOW KITS W/SNAP-IN SCRAPERS

- 9780\* 1 Piece Snap-In Window Kit, 58-64
- 9783\* 1 Piece Snap-In Window Kit, 65 & Later



**\*Note: All 58-64 and 68-77 applications require the use of P/N: 9757 & 9758 1965-67 window regulators and P/N: 9759 window sashes.**

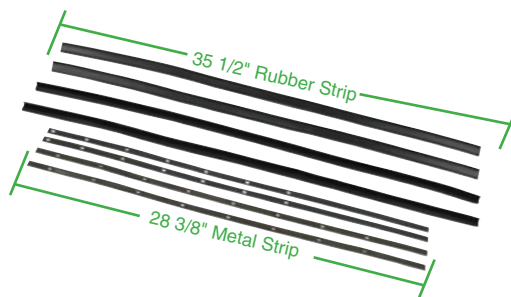

## SNAP-IN KITS

Replace your 1 piece window glue-in scrapers with this new Snap-In Scraper Kit.

- 9772 Snap-In Scraper Kit Only, 58-64
- 9773 Snap-In Scraper Kit Only, 65 & Later

## DOOR STOPS

EMPI's custom designed door stops replace original door stops when installing 1-piece windows and helps prevent the glass from breaking when the door is closed with the window down. Includes hardware.



- 9756 Door Stops, Pair

## GREY TINTED REAR QUARTER WINDOWS

- B600021 **NEW!** Grey Tinted Rear Quarter Windows, 65-77, Pair



### NOTE: TINTED GLASS SPECIFICATIONS

Gray Tinted DOT 3/16"/5mm Glass; Visible Light 52% Transmittance, 5% Reflectance; Total Solar Energy 54% Transmittance, 5% Reflectance; UV 34% Transmittance; U-Value Summer 1.09, Winter 1.10; European U-Value (K-Value) 5.8; Solar Heat Gain Coefficient 0.63; Shading Coefficient 0.76



# EXTERIOR ACCESSORIES

## FENDER BEADING KITS

Finish off your new paint job with new fender beading. Prevents against rust and corrosion by keeping moisture out of body joints. Available in white or black to match or off-set your color scheme.

### HIGH QUALITY FENDER BEADING

With notches for bolts.

- 6729 Fender Beading, Black, Skinpacked, Pair
- 6729-7 **NEW!** Bulk Fender Beading, Pair



### HIGH QUALITY FENDER BEADING

Without notches for bolts.

- 6730 Fender Beading Kit, Black, 25' Length
- 6734 Fender Beading Kit, White, 25' Length



### CUSTOM FENDER BEADING

Available in black for that stock look. Special high quality copolymer. It is precision extruded in a new tooling. Comes in a 25 foot length which is ample for four fenders.

- B601700 **NEW!** Fender Beading Kit w/o Notches, 25', Black

### STANDARD FENDER BEADING

With notches for bolts.

- 3003 Fender Beading, Black, Each
- 3003-8 Fender Beading, Black, Pair  
(Bulk P/N: 111 821 715A, Pair)
- 3048 Fender Beading, Black, Set of 4



## FRONT TURN SIGNAL SEALS

High quality seals include wiring tube on early models just like original. Fits Type 1 VWs.

- 6701 Turn Signal Seals, w/Wiring Tubes Attached, 58-63, Pair  
(Bulk P/N: 111 953 193, Pair)
- 6702 Turn Signal Seals, w/Wiring Tubes Incl., 64-69, Pair (4 pcs.)  
(Bulk P/N: 111 953 193E, Pair, 4 pcs.)
- 6703 Turn Signal Seals, 70-79, Pair  
(Bulk P/N: 113 953 193, Pair)



## TAIL LIGHT SEALS

High quality tail light seals. Fits Type 1.

- 6704 Tail Light Seals, 62-67, Pair  
(Bulk P/N: 111 945 191E, Pair)
- 6705 Tail Light Seals, 68-70, Pair  
(Bulk P/N: 111 945 191G/2A, Pair)
- 6706 Tail Light Seals, 71-72, Pair  
(Bulk P/N: 113 945 191/192, Pair)





6714



6713



6708



6707



3591



3592



98-8133-B



3590



3157



Profile



98-2044



98-2046



98-2048



98-8337-B

## LICENSE LIGHT SEALS

High quality license light seals. Fits Type 1.

- 6714** License Light Seal, 52-57, Each (Bulk P/N: 111 943 191B)
- 6713** License Light Seal, 58-63, Each (Bulk P/N: 111 943 191C)
- 6707** License Light Seal, 64-66, Each (Bulk P/N: 113 943 191)
- 6708** License Light Seal, 67-79, Each (Bulk P/N: 111 943 191E)

## ENGINE SEAL

Stock replacement engine seal. Seals engine tin to body. A must for engine cooling. Fits Type 1.

- 3591** Engine Compartment Seal, thru 66 (Bulk P/N: 111 813 705A)
- 3592** Engine Compartment Seal, 67-74 (Bulk P/N: 111 813 705D)
- 98-8133-B** Seal, Bell Housing, Type 1 50-79, Ghia 56-74, Type 2 55-71 (Ref. P/N: 111 813 741G)

## FRONT HOOD & DECK LID SEALS

Stock replacement seals. Fits all Type 1 and Super Beetle.

- 3590** Front Hood Seal, All Std. Bug & 71-72 S/B (Bulk P/N: 113 823 731B)
- 3588** Front Hood Seal, 73-79 S/B (Bulk P/N: 133 823 731)
- 3598** Rear Deck Lid Seal, All (Bulk P/N: 111 827 705)

## BELLY PAN GASKET

Installs between body and pan providing a water-tight seal. Great for body-off restorations, Kit Cars, Baja Bugs and Dune Buggies.

- 3157** Belly Pan Gasket, Each (Bulk P/N: 113 701 605)

## HANDLE & LOCK SEALS

High quality seals for a factory-new look.

- 98-2044** Hood Handle Seals, Clear, 68-79, Set of 2 (Bulk P/N: 113 823 579A)
- 98-2046** Door Handle Seals, 60-65, Set of 4 (Bulk P/N: 111 837 211A)
- 98-2048** Door Handle Seals, 68-79, Set of 4 (Bulk P/N: 111 837 211C)
- 98-8337-B** Seal Set, Outer Door Handle (2-Large, 2-Small), Type 2 69-79 (Ref. P/N: 211 837 211A)



# EXTERIOR ACCESSORIES

## HANDLES & LOCKS

High quality handles & locks to replace broken, rusted or scratched originals.

### DOOR HANDLES

- 98-1038** Outer Door Handle w/Keys, 68 & Later, Each  
(Bulk P/N: 113 837 205M)
- 98-2032** Keyed Alike Door Handles, 60-64, Pair  
(Bulk P/N: 113 898 205C)
- 98-2034** Keyed Alike Door Handles, 68 & Later, Pair  
(Bulk P/N: 113 898 205M)
- 98-8334-B** Door Handle, Left or Right, Type 2 69-79, Each  
(Ref. P/N: 211 837 205N)

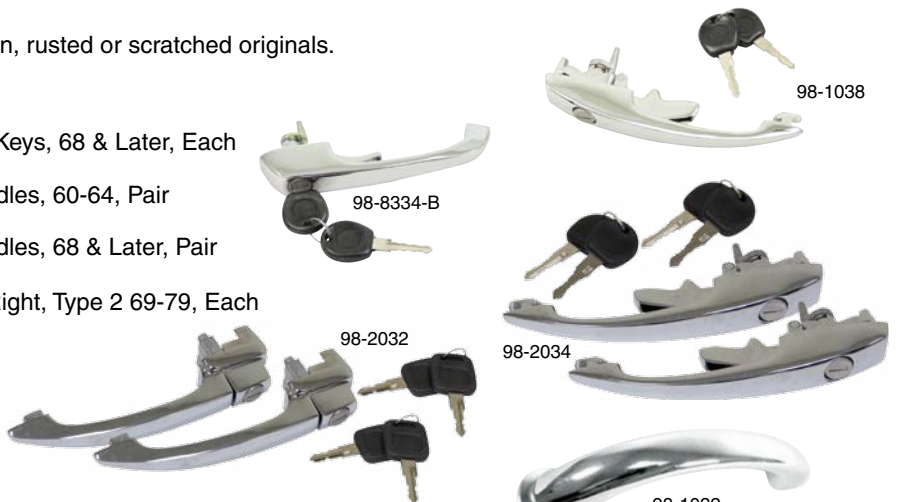

### HOOD HANDLES & COMPONENTS

- 98-1032** Hood Handle, thru 67  
(Bulk P/N: 113 823 565A)
- 98-1033** Hood Handle, 68 & Later  
(Bulk P/N: 113 823 565F)
- 98-1080** Hood Lock Pin, thru 67  
(Bulk P/N: 111 823 507A)
- 98-1081** Hood Lock Pin, 68 & Later  
(Bulk P/N: 111 823 507F)
- 98-1030** Receiver, Front Apron, thru 67  
(Bulk P/N: 111 823 509B)
- 98-1031** Receiver, Front Apron, 69 & Later  
(Bulk P/N: 152 823 509B)



### DECK LID LOCKS

- 98-1090** Deck Lid Lock w/Keys, thru 64  
(Bulk P/N: 113 827 571D)
- 98-1084** **NEW!** Deck Lid Lock w/Keys, 65-66  
(Bulk P/N: 113 827 503A)
- 98-1034** Deck Lid Lock w/Keys, 67-71  
(Bulk P/N: 113 827 503F)
- 98-1035** Deck Lid Lock w/Keys, 72-79  
(Bulk P/N: 113 827 503H)



## TRIM & BODY GUARDS

Trim sets add a custom look, while Door, Hood & Fender guards protect your paint from scratches and dings. **All stainless steel items are "polished"**.

### DOOR HANDLE GUARDS

- 6446** Door Handle Guard, [Stainless Steel](#), Type 1, 56-59, Pair
- 6447** Door Handle Guard, [Stainless Steel](#), Type 1, 60-67, Pair
- 6448** Door Handle Guard, [Stainless Steel](#), Type 1, 68-70, Pair
- 6431** Door Handle Guard, [Aluminum](#), Type 1, 68-70, Pair
- 6432** Door Handle Guard, [Aluminum](#), Type 1, 71-on, Pair

### HOOD HANDLE GUARDS

- 6449** Hood Handle Guard, [Stainless Steel](#), Type 1, thru 67, Includes Gasket
- 6433** Hood Handle Guard, [Aluminum](#), Type 1, 68-on, Includes Gasket



## TRIM & BODY GUARDS (Continued)



98-1053



98-1057 **NEW!**

### HORN GRILLE

- 98-1053** Horn Grille, Type 1, 52-67, Left or Right, Each  
(Bulk P/N: 113 853 641A)
- 98-1057** **NEW!** 3-Bar Horn Grille, 52-72, Each
- 98-1057-B** **NEW!** 3-Bar Horn Grille, 52-72, Bulk, Each



6420



6427

### FRONT & REAR VENT TRIM

- 6420** Front Hood Grille, **Aluminum**, Type 1, 68-77, 71-72 S/B (19 Slots)
- 6427** Front Hood Grille, **Aluminum**, Type 1, 73-79, S/B (19 Slots)
- 6422** Rear Air Intake Grille, **Aluminum**, Type 1, 65-71 (50 Slots)
- 6423** Rear Air Intake Grille, **Aluminum**, Type 1, 72-77 (42 Slots)

**Check Number of Slots Before Ordering**



6422

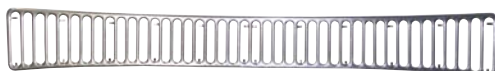

6423

### QUARTER VENT GRILLES, BLACK OR CHROME

Mirror finish Chromed Plastic or Black Plastic Vent Grilles are a stand out on your 71 & later Bug.



98-9982

98-1028

- 98-9982** Chrome Quarter Vent Grilles, Type 1 71 & Later, Pair  
(Bulk P/N: 98-9982-B, Pair)  
(Ref P/N: 113-819-447C/8C, Pair)

- 98-1028** Quarter Grilles, Black Plastic, Type 1, 71-on, Pair  
(Bulk P/B: 98-1028-B, Pair)  
(Ref P/N: 113 819 447A/8A, Pair)



6425



6426

### ENGINE DECK LID TRIM

- 6425** 2-Piece Grille Set, **Aluminum**, Type 1
- 6426** 4-Piece Grille Set, **Aluminum**, Type 1

### HEADLIGHT EYE BROWS

Choose **Stainless Steel**, Chrome or Black, smooth or louvered for that custom or classic look.



6451

6450

- 6458** Eye Brows, Smooth **Stainless Steel**, Type 1, Pair
- 6450** Eye Brows, Smooth Chrome, Type 1, Pair
- 6451** Eye Brows, Louvered Chrome, Type 1, Pair
- 6454** Eye Brows, Louvered Black, Type 1, Pair

### CAT EYES

Gleaming Chrome Cat Eye headlight covers add a custom look to your VW.

- 6457** Cat Eye Headlight Covers, Pair



6457

### VENT SHADES

**Stainless Steel** Vent Shades allow you to roll down your windows slightly without the effects of wind and rain.

- 9741** S/S Vent Shades, Type 1, 53-64, Pair
- 9740** S/S Vent Shades, Type 1, 65-77, Pair
- 9742** S/S Vent Shades, Type 2, 68-79, Pair
- 9743** S/S Vent Shades, Type 3, 66-74, Pair



9740





# EXTERIOR ACCESSORIES

## STAINLESS STEEL FENDER GUARDS

These durable highly polished Stainless Steel Fender Guards will protect your paint job for years with little or no maintenance. Choose from the contemporary style of the 60's and 70's, or the early vintage look.

- 6444 Vintage Fender Guards, [Stainless Steel](#), Rear, Type 1, Pair, w/Hardware
- 6439 Fender Guards, Front, [Stainless Steel](#), Type 1, Pair, w/Plastic Trim
- 6440 Fender Guards, Rear, [Stainless Steel](#), Type 1, Pair, w/Plastic Trim



## ALUMINUM FENDER GUARDS

Protect your paint from stones and road debris with our fender guards. Available in durable aluminum finish with plastic trim.

- 6436 Fender Guards, Front, [Aluminum](#), Type 1, Pair
- 6434 Fender Guards, Rear, [Aluminum](#), Type 1, Pair



## EMPI MUD FLAPS

An EMPI exclusive. Heavy duty mud flaps with the EMPI logo. Choose black with white logo, or white with black logo. Includes mounting hardware. Fits Type 1, thru 67 (68-73 with slight modifications). Type 2 Bus is also available. Sold in pairs.

- 15-1090 Mud Flaps, Black w/White Logo, Type 1, Pair
- 15-1091 Mud Flaps, White w/Black Logo, Type 1, Pair
- 15-1092 Mud Flaps, Black w/White Logo, Type 2, thru 72, Pair
- 15-1093 Mud Flaps, White w/Black Logo, Type 2, thru 72, Pair



## DECK LID RAIN DEFLECTOR

Easy to install, this deflector keeps rain out of your engine compartment while allowing cool air in. Made from high-impact black plastic. Hardware included.

- 6464 Deck Lid Rain Deflector w/Hardware, All Type 1



## EMPI VINTAGE TYPE 2 SIDE STEPS

It's back...It's true, EMPI has re-issued the vintage Type 2 Front Side Step. The EMPI step is by far one of the most popular and sought after early Type 2 accessories. True to the original, we have faithfully reproduced the step to be just like the original with the EMPI logo as the step! Fits early bus 1959-1967. Two steps are included for left and right sides with zinc plated brackets and mounting hardware. The EMPI Front Side Step is one of the first items to be reintroduced for the "EMPI Vintage Parts" program. Now also available with a machined and polished 6061 T-6 Billet Aluminum EMPI logo for that custom Cal-Look application! **The Aluminum Step has a female thread in the center. The rubber step has a stud offset to one side. Left and Right are the same.**

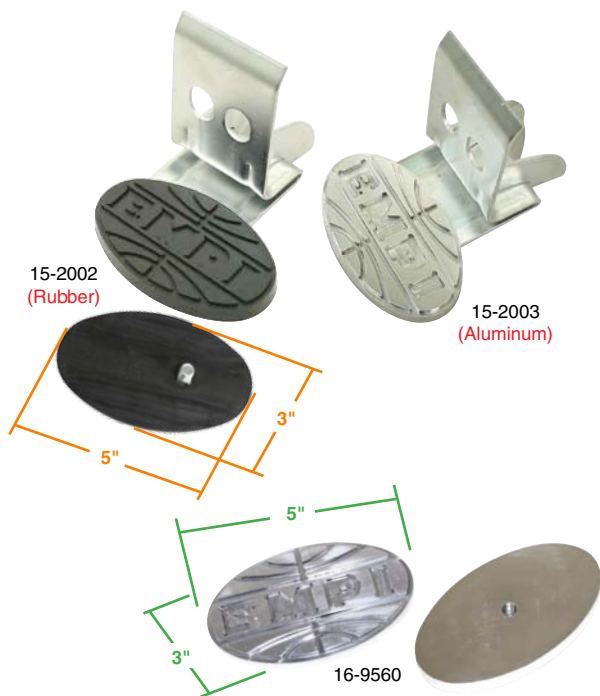

- |         |  |
|---------|--|
| 15-2002 | Vintage Type 2 Side Step, Pair                       |
| 15-2003 | EMPI Aluminum Bus Step, Pair                         |
| 16-9560 | EMPI Billet Aluminum Step,<br>3/8" x 24 Thread, Pair |

## SIDE SCOOPS - TYPE 2

Get maximum air flow to the engine compartment. Bus Scoops are made of white paintable plastic. Mounts over existing air intakes. Fits Type 2 thru 67.



- |      |                                       |
|------|---------------------------------------|
| 4212 | Van Air Scoops, Type 2, thru 67, Pair |
|------|---------------------------------------|

## SPARE TIRE KIT - TYPE 2

Allows you to move your spare tire out of your interior and on to the front of your Type 2. Complete kit includes mount bracket, tire cover and mounting hardware. Works with early & late Type 2 wheels.



4222



4225

- |      |                                  |
|------|----------------------------------|
| 4219 | Spare Tire Kit w/Black Cover     |
| 4220 | Spare Tire Kit w/Off-White Cover |
| 4222 | Replacement Cover, Black         |
| 4223 | Replacement Cover, Off-White     |
| 4225 | Spare Tire Mount Only w/Hardware |



# EXTERIOR ACCESSORIES

## FRONT HOOD GAS STRUTS

If you're tired of that same old "squawk" when you open the front hood, we've got just what you need. These up-to-date struts are an affordable and functional update to any street or show car and provide the correct amount of resistance to avoid buckle.

16-9542 Front Hood Gas Struts, Type1 except 73 1/2-79 S/B, Pair

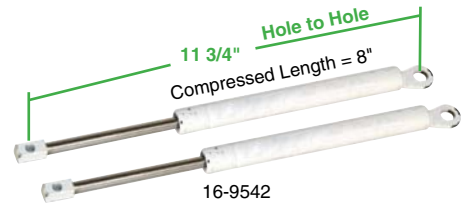

## CHROME DECK LID BRACKETS & SPRING

Replaces stock brackets and spring with Chrome versions.

8661 Chrome Deck Lid Spring, Each  
8662 Chrome Deck Lid Brackets, Pair



## BILLET ALUMINUM DECK LID STAND-OFF

Trick looking Polished Billet Aluminum Deck Lid Stand-off functions to raise your deck lid about 2.5" while looking awesome. Comes with set screws. Fits early T-handle cars only, 50-64.

17-2948 Billet Aluminum Deck Lid Stand-Offs, Type 1, Each



## DECKLID HINGE BRACKET

16-9837 Decklid Hinge Bracket, M6-1.0 Threaded, Pair  
16-9837-7 Bulk Decklid Hinge Bracket, M6-1.0 Threaded Type 1 1950-79, Each  
(Bulk P/N: 111 827 171)



## DECK LID STAND-OFFS

Bolts between your deck lid brackets and body to lift and hold top of deck lid away from the body allowing improved cooling. Made from cast aluminum. Fits all Type 1.

9141 Deck Lid Stand-Offs w/Hardware, Pair

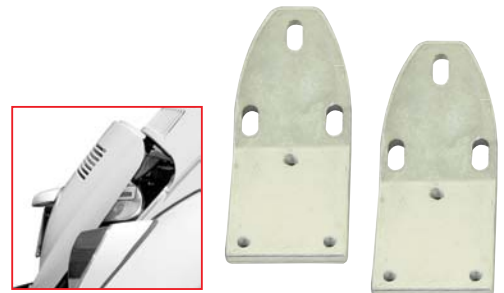

## DECK LID QUICK RELEASE PINS

By removing the existing deck lid hinge pins and using these quick release clip/pins you can easily remove your deck lid for engine tuning any time you want. Great for sedans with dual carburetors where you can never get your arm into the right spot or for those of you who happen to always hit their head on the deck lid!

8669 Deck Lid Quick Release Clips, Pair



## MOLDING KITS

Replace those old and dull moldings with our high quality bright anodized aluminum 7 piece molding kits. Fits Type 1, Bugs, except Super Beetle. **(Clips are not included).** Each kit is boxed.



- 98-1060-B** 7-Piece Molding Kit, Type 1, 63-66  
(Ref. P/N: 111 898 111A)  
**98-1059-B** 7-Piece Molding Kit, Type 1, 68-72  
(Ref. P/N: 113 898 111)

## MOLDING CLIPS



- 98-1051** Molding Clip, Type 1,  
Fits both standard and S/S moldings, 52-66,  
Pack of 50  
(Bulk P/N: 113 853 585B, Bulk Pack of 100)  
**98-1052** Molding Clip, Type 1,  
Fits both standard and S/S moldings, 67-79,  
Pack of 50  
(Bulk P/N: 113 853 585C, Bulk Pack of 100)  
**98-9973** Molding Clip,  
Type 1 Convertible, 50-64, Ghia 56-71,  
Pack of 50  
This clip holds the chrome and the rubber strip  
on the top edge of the doors.  
(Bulk P/N: 151 898 235, Bulk Pack of 100)

## STAINLESS STEEL FIREWALL KITS

Give your VW that show car finish with these highly polished Stainless Steel firewall panels. Choose between smooth or louvered. Fits Type 1, Bugs (Exc. Convertible). (Bulk Firewalls are in packs of 5 each)



### LOUVERED FIREWALL KITS

Large piece is Louvered and side pieces are Smooth

- 62-3020** 3-Piece Firewall Kit, Louvered, Each  
**62-3020-9** Bulk 3-Piece Firewall Kit, Louvered  
(Must Buy Multiples of 5)

### SMOOTH FIREWALL KITS

All 3 pieces are Smooth

- 62-3030** 3-Piece Firewall Kit, Each  
**62-3030-9** Bulk 3-Piece Firewall Kit  
(Must Buy Multiples of 5)







# EXTERIOR ACCESSORIES

## ALUMINUM FIREWALL PANELS

Get that Pro Stock look with these Aluminum Firewall Panels. Our 3-piece kit covers the sides and front firewall of all Type 1's, Bugs. We have your Karmann Ghia covered too, with our 5 piece kit.

- 62-3050 Type 1, 3-Piece Aluminum Firewall Kit, Each  +
- 62-3060 Karmann Ghia 5-Piece Aluminum Firewall Kit  +

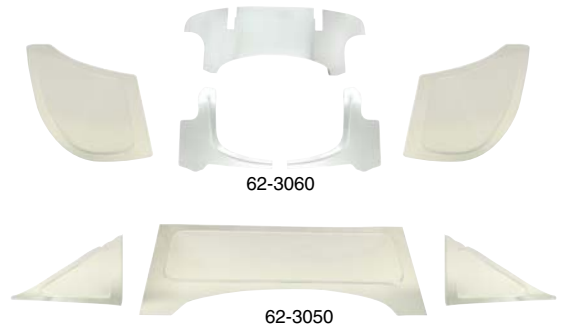

## HEAVY DUTY FIREWALL INSULATION KIT



Helps keep engine noise and heat where it belongs...in the engine compartment. Fits Type 1, Bugs, trimming required for convertibles.

- 98-1062-B Firewall Insulation Kit, 3 pcs. (5.0mm thick)  
(Ref. P/N: 113 898 805HD)



## FRONT TRUNK LINERS

These stock fiberboard liners are a perfect replacement for old, worn out or missing liners.

- 98-1082-B Trunk Liner, Type 1, 61-67  +  
(Ref. P/N: 113 863 509C)
- 98-1083-B Trunk Liner, Type 1, 68-77 (Exc. S/B)  +  
(Ref. P/N: 113 863 509F)



## EMPI SPARE TIRE TOOL BOX

EMPI brings back another old favorite with our reproduction of the ever popular and useful spare tire tool box. The EMPI globe logo embossed lid folds down to reveal a true to original assortment of tools to help with roadside repairs. Fits all stock and chrome rims that utilize hub cap clips (5 Lug x 205mm). Supplied with tools. Tools supplied should be considered for show only and not for actual use.

- 15-2016 EMPI Spare Tire Tool Box

## SPARE TIRE COVER / TOOLBAG

A Two-fer...covers your spare tire and neatly holds tools – wrenches, screwdrivers, etc. Made of Black vinyl. Fits Type 1 & Ghia For 15" Wheel. Tools not included.

- 4290 Spare Tire Cover / Toolbag, each



## WIRE COVERS

Replace your stock fiberboard cover with this durable ABS plastic wire cover. Features black crinkle finish. Can be painted if desired.

- 3570-B Wire Cover, Type 1, 55-67  
(Ref. P/N: 113 863 515C)
- 3571-B Wire Cover, Type 1, 68-77 (Exc. S/B)  
(Ref. P/N: 113 863 515H)
- 3565-B Wire Cover, Karmann Ghia  
(Ref. P/N: 141 863 515C)





4590

**Blue Glass**



## EMPI SPORT MIRRORS

EMPI mirrors offer style, performance, great looks and visibility. Fully adjustable with universal mounting. They fit most models of cars.

## EMPI MINI SPYDER MIRROR

The EMPI Mini Spyder Mirror is very similar to the Baby Turbo Mirror without duplicating the "Italian" price. Exclusive base design assures proper fit to Type 1 sedan. Blue tinted glass reduces glare. **Comes in an attractive clear plastic EMPI display box. This mirror is universal fit, left or right.**

4590

EMPI Mini Spyder Mirror, Left or Right, Each



4565

## MINI SPYDER STYLE MIRROR

An economical version of the EMPI Mini Spyder mirror but without the blue mirror glass and the EMPI display packaging. Shipped in a plain box.

4565

Mini Spyder Style Mirror, Left or Right, Each

**Blue Glass**



4591

## EMPI MINI SPRINT MIRROR

The EMPI Mini Sprint Mirror replicates the Baby Tornado Mirror in all ways except one...the "Italian" price tag. Specially designed by EMPI, the base easily allows for "level" mirrors when installed on Beetle doors! Comes with blue tinted glass to help reduce glare. **Both left or right mirrors are shipped in EMPI clear plastic display boxes.**

4591

EMPI Mini Sprint Mirror, Left

4592

EMPI Mini Sprint Mirror, Right



## EMPI EMBLEMS

Die Cast EMPI and EMPI GTV Logos. Emblems attach easily to your VW without drilling.



6455

6455

"EMPI" Emblem, Each



6456

6456

"EMPI GTV" Emblem, Each

## CHROME EMBLEMS & HORN GRILLES

Use for dress-up or to make a statement. Attaches easily to hood, deck lid or most any location.



98-1053

3183

"Street Machine" Emblem, Each

3184

"Hot Rod" Emblem, Each

3187

"Cal-Look" Emblem, Each

*Streetmachine*  
*CalLook*  
*Hotrod*

98-1053

Horn Grille, Type 1, 52-67, Left or Right, Each

(Bulk P/N: 113 853 641A)



98-1057 **NEW!**

98-1057

**NEW!**

3-Bar Horn Grille, 52-72, Each

98-1057-B

**NEW!**

3-Bar Horn Grille, 52-72, Bulk, Each



# EXTERIOR ACCESSORIES

## STOCK-STYLE MIRRORS

Complete your restoration with replacement mirrors. Right side mirrors increase rear visibility. All items listed come in skinpack display cards. Order the bulk part number if you want it bulk, boxed.

**98-2013** Mirror, Type 1, thru 67, Round, Left  
(Bulk P/N: 113 857 513A) (Use P/N: 98-2101 Threaded Door Hinge Pin)

**98-2014** Mirror, Type 1, thru 67, Round, Right  
(Bulk P/N: 113 857 514A) (Use P/N: 98-2101 Threaded Door Hinge Pin)

**98-8581** Mirror, Type 1, thru 67, Oval, Left  
(Bulk P/N: 113 857 513ATD) (Use P/N: 98-2101 Threaded Door Hinge Pin)

**98-8582** Mirror, Type 1, thru 67, Oval, Right  
(Bulk P/N: 113 857 514ATD) (Use P/N: 98-2101 Threaded Door Hinge Pin)

**98-2101** **Mirror Hinge Pin**, Type 1, thru 67, Each  
(Bulk P/N: 111 831 421)

**98-2015** Mirror, Type 1 Sedan, 68 & Later, Left  
(Bulk P/N: 113 857 513D) Black trim around glass

**98-2016** Mirror, Type 1 Sedan, 68 & Later, Right  
(Bulk P/N: 113 857 514D) Black trim around glass

**98-8571** Mirror, Type 1 Convertible, 68 & Later, Left  
(Bulk P/N: 151 857 501)

**98-8572** Mirror, Type 1 Convertible, 68 & Later, , Right  
(Bulk P/N: 151 857 502)

**98-8573** Mirror, Type 2, thru 67, Left or Right, Each  
(Bulk P/N: ZVW 151 201) (Elephant Ear Style) Black trim around glass

**98-9976** Mirror, Type 2 to 67, Left, Ea.  
(Bulk P/N: 98-9976-B Includes Mirror, Arm and Clamp)

**98-9977** Mirror, Type 2 to 67, Right, Ea.  
(Bulk P/N: 98-9977-B Includes Mirror, Arm and Clamp)

**98-2017** Mirror, Type 2, 68-79, Left  
(Bulk P/N: 211 857 513F) Grey trim around glass

**98-2018** Mirror, Type 2, 68-79, Right  
(Bulk P/N: 211 857 514F) Grey trim around glass

**98-9974** Mirror, Ghia 66 & Later, Left, Ea.  
(Bulk P/N: 141 857 501)

**98-9975** Mirror, Ghia 66 & Later, Right, Ea.  
(Bulk P/N: 141 857 502)

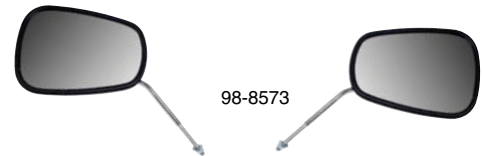
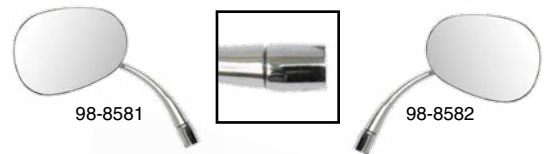

98-9553



98-9554



98-9551



98-9558



98-9552



98-9555



98-9549

**NEW!**

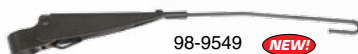

98-9550

**NEW!**

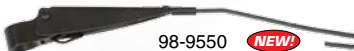

98-9556



98-9557



98-9642



**BOSCH**

98-9564-B



98-9565-B



98-9559-B



98-9566-B



98-9644-B

**NEW!**



98-9548-B

**NEW!**



98-9643-B



98-9645-B

**NEW!**



## WIPER ARMS AND BLADES

**98-9553** Wiper Arm, Silver, Left or Right, Type 1 58-64  
(Bulk P/N: 113 955 407B)

**98-9554** Wiper Arm, Silver, Left or Right, Type 1 65-67  
(Bulk P/N: 113 955 407D)

**98-9551** Wiper Arm, Silver, Left, Type 1 68-69  
(Bulk P/N: 111 955 407D)

**98-9558** Wiper Arm, Silver, Right, Type 1 68-69  
(Bulk P/N: 111 955 408)

**98-9552** Wiper Arm, Silver, Left, Type 1 70-72  
(Bulk P/N: 111 955 407F)

**98-9555** Wiper Arm, Silver, Right, Type 1 70-72  
(Bulk P/N: 111 955 408B)

**98-9549** **NEW!** Wiper Arm, Black, Left, Type 1 73-77 (Exc. S/B)  
Super Beetle Sedan 71-72  
(Bulk P/N: 111 955 407)

**98-9550** **NEW!** Wiper Arm, Black, Right, Type 1 73-77 (Exc. S/B)  
Super Beetle Sedan 71-72  
(Bulk P/N: 111 955 408)

**98-9556** Wiper Arm, Black, Left, S/B 73-79  
(Bulk P/N: 133 955 409)

**98-9557** Wiper Arm, Black, Right, S/B 73-79  
(Bulk P/N: 133 955 410)

**98-9642-B** Wiper Arm, Silver, Type 2 to 67, Left or Right  
(Ref P/N: 221 955 407A)

## REPLACEMENT WIPER BLADES

**98-9564-B** **Bosch** Wiper Blade, Black, 16", Type 2 68-79, Each  
(Ref. P/N: 40-716A) Includes Universal Adapters

**98-9565-B** **Bosch** Wiper Blade, Black, 18", Vanagon 80-91, Each  
(Ref. P/N: 40-718A) Includes Universal Adapters

**98-9559-B** Wiper Blade, 10" / 255mm, Black, Type 1 58-64,  
Type 2 50-67, Each  
(Ref. P/N: 113 955 425B)

**98-9566-B** Wiper Blade, 10" / 255mm, Silver, Type 1 58-64,  
Type 2 50-67, Each  
(Ref. P/N: 113 955 425S)

**98-9644-B** **NEW!** Wiper Blade, 10.5" / 268mm, Silver, Type 1 65-67, Each  
(Ref. P/N: 111 955 425B)

**98-9548-B** **NEW!** Wiper Blade, 11.3" / 288mm, Black,  
Type 1 68-77 (Exc. S/B), Super Beetle 71-72  
(Ref. P/N: 111 955 425F)

**98-9643-B** Wiper Blade, 10.75" / 274mm, Silver, Type 2 to 67, Each  
(Ref P/N: 221 955 425C)

**98-9645-B** **NEW!** Wiper Blade, 10.75" / 274mm, Black, Type 2 to 67, Each  
(Ref P/N: 221 955 425CBL)

## ELECTRIC WINDSHIELD WASHER KIT

Universal design allows for use on most any application. Ideally suited for mounting and use on Type 1, 2 or 3's. 12-Volt motor is built into the see-thru plastic reservoir tank and all mounting hardware and wiring is included.

15-2060

Universal Wiper/Washer Kit

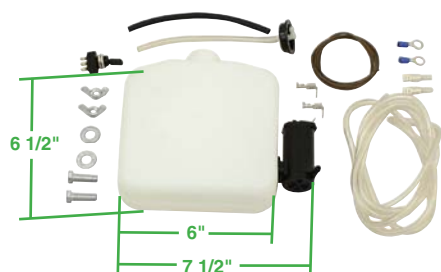





# EXTERIOR ACCESSORIES

## DELUXE CUSTOM FIT CAR COVERS

Pamper and protect your car with our Deluxe Car Covers. The thick water-resistant outer layers provide protection from the elements and impact while maintaining a high level of breathability. The diaper soft inner layer protects against scratches and abrasion. The Revolution material is highly resistant to rips tears and puncture. Deluxe Revolution Car Covers are custom tailored for each application (No antenna Pockets).



- 15-6401 Deluxe Car Cover, All Type1 & Super Beetle (w/Mirror Pockets)
- 15-6411 Deluxe Car Cover, Type 3 Squareback
- 15-6403 Deluxe Car Cover, All Karman Ghia (w/Mirror Pockets)
- 15-6405 Deluxe Car Cover, Type 2, 50-72
- 15-6407 Deluxe Car Cover, Type 2 Bus, 73-79
- 15-6409 Deluxe Car Cover, Type 2 Camper, 68-92



## REPLACEMENT ANTENNAS

Stock-style replacement antennas. Poly bag for easy displaying.

- 58-3500 Antenna, Sidemount, Bug & Bus (48" Cable)
- 58-3501 Antenna, Bug, 67-79 (48" Cable)
- 58-3503 Antenna, Ghia Basemount (48" Cable)
- 58-3506 Antenna, Dual Base, Sidemount w/Chrome Mounts (60" Cable)

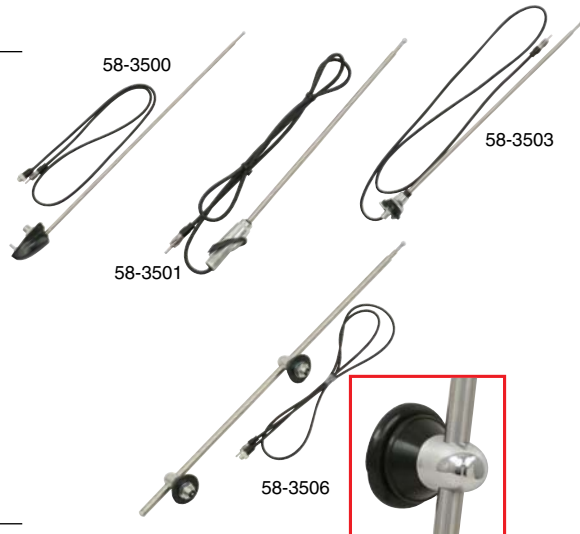

## CUSTOM MIRRORS

Different shapes and sizes for your street car or sand car complete with 5 pc. hardware kit. Hardware kit includes two (2) 10mm-1.25 right hand thread studs, one (1) 10mm-1.25 left hand thread stud, and two (2) 8mm-1.25 right hand thread studs. All studs are 8mm x 1.25 right hand thread on short end. Modification necessary for stock application.

- 16-9838 Arrowhead Billet Mirror, Pair
- 16-9839 Barefoot Billet Mirror, Pair

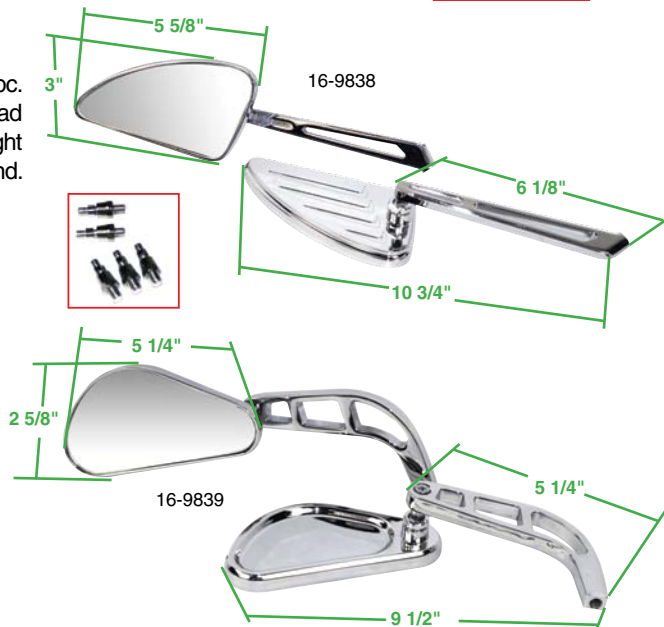

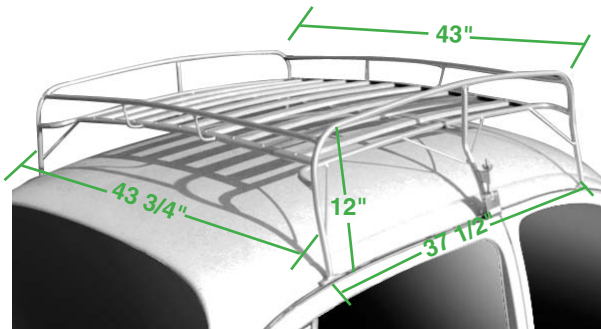

## TYPE 1 ROOF RACK (KNOCK DOWN)

EMPI recreated this popular VW accessory from the 50's and 60's to hold your luggage, cooler or camping gear securely while looking Old Skool Cool. Made from tubular steel and jig welded for a perfect fit, it comes finished in Silver Power Coated, and features wood slats just like the originals. Built in a 'Knock-Down' design, they can ship via standard UPS.



15-2012

15-2012

Roof Rack, Silver Powder Coat, K/D, Bug,



15-2008

**NEW!**

## TYPE 2 SHORT ROOF RACK (KNOCK-DOWN)

This New Roof Rack for the Cab portion of your bus or transporter. Made from tubular steel and jig welded for a perfect fit. It comes finished in Silver Powder Coat with hardwood slats and zinc plated hardware. Fits on all years of Single Cab, Double Cab or Bus. Built in a 'Knock-Down' design that can ship UPS. Adds 5 3/4" to the height of your vehicle.

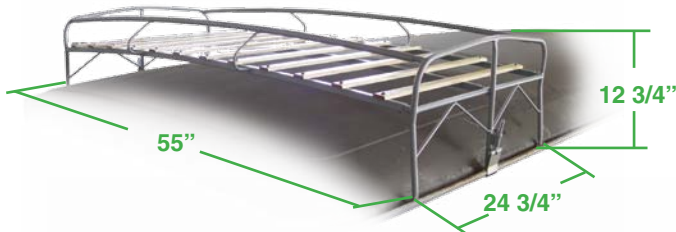

15-2008 **NEW!**

Type 2 Short Roof Rack, Type 2 50-79,

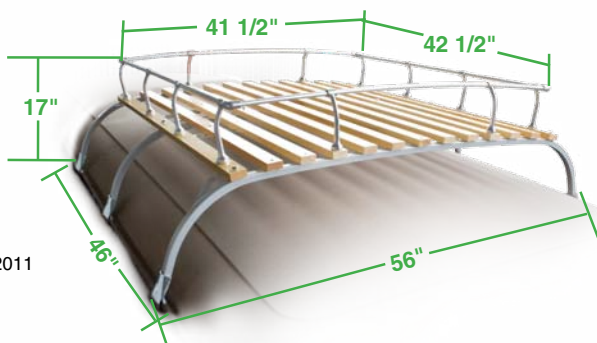

15-2011

15-2011

Roof Rack, Type 2, 50-79



# EXTERIOR ACCESSORIES

## DECK LID RACK (KNOCK DOWN)

Our remake of this popular vintage accessory features a silver powder coated frame, stainless steel hardware and quick access to the engine. The perfect companion to our roof rack. Fits sedans up to 1967.

15-2014 Deck Lid Rack, Type 1, thru 67

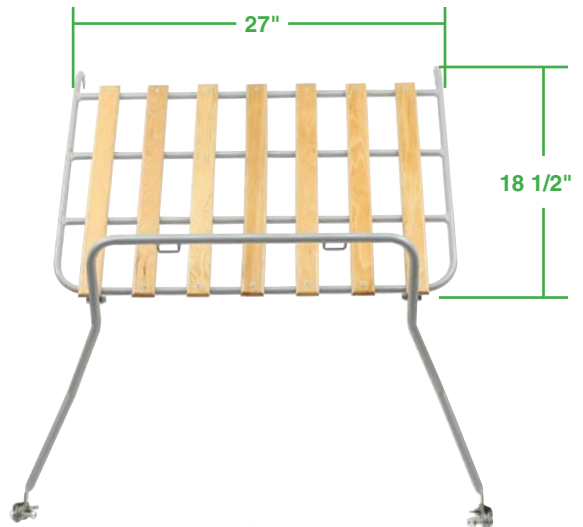

## ROOF RACK LOCKS

Designed for use on sedan roof racks, yet this can easily be used anywhere a 5/16"-18 thread and your imagination requires it. Includes weatherproof caps for top of locks and two keys. Fits EMPI roof racks 15-2008 and 15-2012 only.

15-2005 Roof Rack Locks, Pair



## SUN VISOR

Fiberglass sun visor adds that custom look and aids visibility. Paint to match your VW. Fits all Type 1 and Super Beetle. (Fitting necessary).

6467 Sun Visor, Each  +



## DECK LID RAIN DEFLECTOR

Easy to install, this deflector keeps rain out of your engine compartment while allowing cool air in. Made from high-impact black plastic. Hardware included.

6464 Deck Lid Rain Deflector w/Hardware, All Type 1



## EMPI LICENSE PLATE FRAME

License plate frame with EMPI logo.

6461 EMPI USA License Plate Frame, Front, Each  
6460 EMPI USA License Plate Frame, Rear, Each



## RACE-TRIM RECLINING LOW BACK BUCKET SEATS



62-2961

**GIVE YOUR VW THAT  
VINTAGE | CUSTOM  
LOOK**



62-2960

**NEW!**

**VINTAGE | CUSTOM  
STITCH PATTERN**



62-2951

62-2950



**Perfect Replacement for that Worn Out Original Seat. All New Black Vinyl Low-Back Bucket Seats. Featuring left and right side seats with reclining backs. Seat back pops forward with lever for rear entry. Your choice of with or without headrest.**

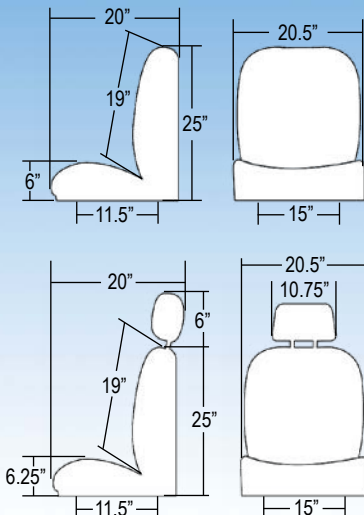

- 62-2950** **NEW!** Low-Back Seat Only, Left Side, Black Vinyl, Each
- 62-2951** **NEW!** Low-Back Seat Only, Right Side, Black Vinyl, Each
- 62-2960** **NEW!** Low-Back Seat w/ Headrest Only, Left Side, Black Vinyl, Each
- 62-2961** **NEW!** Low-Back Seat w/ Headrest Only, Right Side, Black Vinyl, Each

- 62-2865** **NEW!** Rear Seat Covers Only  
Fits Type 1 58-76





## RACE-TRIM RECLINING LOW BACK SEAT ADAPTERS

**NEW!**

62-2872

62-2870 / 62-2871

62-2874

### **Type 1 Bug and Super Beetle**

**Bolt-In Adapter Kits with Sliders designed for EMPI Reclining Low-Back Bucket Seats. No welding required. Kits are complete with sliders and all necessary hardware.**

***These kits are designed to be used only with EMPI Seats 62-2950 / 62-2951 / 62-2960 and 62-2961***

- 62-2870** **NEW!** Bolt-In Seat Mount Adapter Kit w/ Sliders, Wire, & Instructions, Type 1, 56-70 Left Front, Each
- 62-2871** **NEW!** Bolt-In Seat Mount Adapter Kit w/ Sliders, Wire, & Instructions, Type 1, 56-70 Right Front, Each
- 62-2872** **NEW!** Bolt-In Seat Mount Adapter Kit w/ Sliders, Wire, & Instructions, Type 1, 71-72, Fits Either Left or Right Front, Each
- 62-2874** **NEW!** Bolt-In Seat Mount Adapter Kit w/ Sliders, Wire, & Instructions, Type 1, 73-79, Fits Either Left or Right Front, Each



4638

## VINYL SEAT COVERS - SLIP-ON STYLE

Made from high quality vinyl, our Slip-On Style seat covers feature the original 'Basket Weave' pattern with heavy duty Velcro Fasteners for easy installation with no special tools required. Install over your existing covers or remove and replace your old seat padding with our Foam Seat Pads. Fits sedan models.

Heavy  
Duty  
Velcro  
Fasteners



- 4636 Complete Set, Type 1 58-64, Black
- 4637 Complete Set, Type 1 65-67, Black
- 4638 Complete Set, Type 1 68-69, Black
- 4639 Complete Set, Type 1 70-72, Black
- 4640 Complete Set, Type 1 1973, Black
- 4641 Complete Set, Type 1 74-76, Black



4670

## MOLDED FOAM SEAT PADS

Pre-formed injection-molded high density foam rubber designed to fit your seat frame and upholstery for a factory finish. A layer of burlap or sisel should be installed between the foam and your springs to protect the foam for longevity. **Each kit contains one seat bottom foam and one seat back foam.**

- 4670 **NEW!** Molded Foam Seat Pads, Type 1 58-64, 2 Piece Kit
- 4671 **NEW!** Molded Foam Seat Pads, Type 1 65-67, 2 Piece Kit
- 4672 **NEW!** Molded Foam Seat Pads, Type 1 68-72, 2 Piece Kit
- 4673 **NEW!** Molded Foam Seat Pads, Type 1 1973, 2 Piece Kit
- 4674 **NEW!** Molded Foam Seat Pads, Type 1 74-Later, 2 Piece Kit

**NEW!**



4459

## FOAM SEAT PADS

Foam pads replace worn or missing original seat padding. Cut to fit as original, install when re-covering seats for a professional finish.



4465

- 4445 Foam Front Seat Bottoms, Type 1 56-76, Pair
- 4459 Foam Front Seat Bottoms, Type 1 56-76, Each
- 4460 Foam Front Backrest, Type 1 65-67, Each
- 4461 Foam Front Backrest, Type 1 56-64, 68-72, Each
- 4462 Foam Front Backrest, Type 1 73 Only, Each
- 4463 Foam Front Backrest, Type 1 74-76, Each
- 4465 Foam Rear Seat Base, Type 1 56-79, Each
- 4466 Foam Rear Seat Backrest, Type 1 56-64, Each
- 4467 Foam Rear Seat Backrest, Type 1 65-79, Each



4467



# INTERIOR ACCESSORIES

## SEAT BELTS

Four different styles to choose from; 2 Point Universal Lap Belt with Push Button Latch, 2 Point Universal Lap Belt with Chrome Latch Design, 2 Point Retractable Lap Belt with Push Button Latch or our Retractable 3 Point Belt and Shoulder Harness. All of these are made from 2" automotive web material. Mounts to stock anchor locations. All of these come complete with hardware. Retractable 3 Point Belt and Shoulder Harness fits 68-79 Type 1.

Available in 5 colors, Black, Red, Tan, Blue and Grey.

**(Not for competition use)**

### 2 Point Lap Belt With Push Button Latch w/ Hardware

**(Not for competition use)**

- 3844 2 Point Lap Seat Belt, Universal 72", Black, Each
- 18-1021 **NEW!** 2 Point Lap Seat Belt, Universal 72", Red, Each
- 18-1022 **NEW!** 2 Point Lap Seat Belt, Universal 72", Tan, Each
- 18-1020 **NEW!** 2 Point Lap Seat Belt, Universal 72", Blue, Each
- 18-1023 **NEW!** 2 Point Lap Seat Belt, Universal 72", Grey, Each



### 2 Point Lap Belt With Chrome Latch Buckle w/ Hardware

**(Not for competition use)**

- 18-1024 **NEW!** 2 Point Lap Seat Belt, Universal 72", Black, Each
- 18-1026 **NEW!** 2 Point Lap Seat Belt, Universal 72", Red, Each
- 18-1027 **NEW!** 2 Point Lap Seat Belt, Universal 72", Tan, Each
- 18-1025 **NEW!** 2 Point Lap Seat Belt, Universal 72", Blue, Each
- 18-1028 **NEW!** 2 Point Lap Seat Belt, Universal 72", Grey, Each



### 2 Point Retractable Lap Belt With Push Button Latch w/Hardware

**(Not for competition use)**

- 3847 2 Point Retractable Lap Seat Belt, Black, Pair  
Extends out another 40 inches



### 3 Point Retractable Belt / Harness with Hardware

Fits 68-79 Type 1. Sold in pairs / sets. **(Not for competition use)**

- 3851 3 Point Retractable Seat Belt/Harness, Black, Pair
- 18-1029 **NEW!** 3 Point Retractable Seat Belt/Harness, Red, Pair
- 18-1030 **NEW!** 3 Point Retractable Seat Belt/Harness, Tan, Pair
- 18-1031 **NEW!** 3 Point Retractable Seat Belt/Harness, Blue, Pair
- 18-1032 **NEW!** 3 Point Retractable Seat Belt/Harness, Grey, Pair





4854/4854-9

## EMPI DOOR PANEL KITS

With EMPI's new Universal Door Panel Kit you only need to stock one part number for all 65-77 Type 1 sedans. The innovative design has knock-outs for early and late handle locations, also the clip holes are spaced to accommodate early and late spacing patterns for a perfect fit. The rear panels even have a knock-out for the ash tray. Constructed out of Masonite, (Not cardboard) and O.E. style vinyl for durable long life and that original look. The front door panels feature map pockets on both left and right sides. Each kit includes front and rear, left and right panels. All EMPI Panel Kits feature map pockets both right and left.



### TYPE I SEDAN

**4852**  
**4852-9**

4-Piece Panel Kit, 58-64, Black +  
Bulk 4-Piece Panel Kit, 58-64, Black (Must Buy Multiples of 5) +

**4854**  
**4854-9**

4-Piece **Universal** Door Panel Kit, Type 1, 65-77, Black (Exc. Conv.) +  
Bulk **Universal** Door Panel Kit, Type 1, 65-77, Black (Exc. Conv.) +  
(Must Buy Multiples of 5)



4854  
4854-9

*Perforated Knock-Out for Early  
and Late Handle Locations*



16-7555

## ALUMINUM DOOR PANELS

We precision cut these panels from thick aluminum sheet then put a bead roll in from the edges for strength. A perfect match for our Aluminum Dash Panels. Requires holes to be cut for door and window shafts.

**16-7554**  
**16-7555**

**Aluminum** Front Door Panels, Type 1, 56-64, Pair +  
**Aluminum** Front Door Panels, Type 1, 65-79, Pair +

**16-7557**  
**16-7558**

**Aluminum** Rear Quarter Panels, Type 1, 56-64, Pair +  
**Aluminum** Rear Quarter Panels, Type 1, 65-77, Pair +



16-7558

## ALUMINUM DASH PANELS

We precision cut these panels from thick aluminum sheet then bead roll in from the edges for strength. A perfect match for our Aluminum Door Panels.

**16-7550**  
**16-7551**

**Aluminum** Dash Panel, Type 1, 58-64  
**Alum.** Dash Panel, Type 1, 65-on (Exc. Super Beetle)



16-7551



16-7550





# INTERIOR ACCESSORIES

## DOOR PANEL CLIPS & BOOTS

Replace broken or missing clips and boots for a secure professional installation. For use with stock or custom style door panel kits.

- 4846** Door Panel Clips, 50 pcs.
- 4846-B** Bulk Door Panel Clips, Bag of 100 pcs.  
(Ref. P/N: N 14 389 1)
- 4847** Door Panel Clip Boots, 50 pcs.
- 4847-B** Bulk Door Panel Clip Boots, Bag of 100 pcs.  
(Ref. P/N: 113 857 219A)



## STOCK STYLE ARM RESTS

Quality molded urethane arm rests feature original style and pattern. Fits Type 1. P/N 4443 and P/N 4444 will fit EMPI P/N 4854 door panels.

- 4442** Armrest, 58-67, Black, Pair, Boxed
- 4443** Armrest, 68-72, Black, Pair, Boxed
- 4444** Armrest, 73-79, Type 1 & S/B, Black, Pair, Boxed



## EMPI UNIVERSAL DOOR PULLER

EMPI has brought back its original style chrome door pulls. These classic chrome pull handles provide a sturdy way to close your door and are spring loaded to stay snug against the door when not in use.

- 15-2080** EMPI Universal Door Puller, Pair

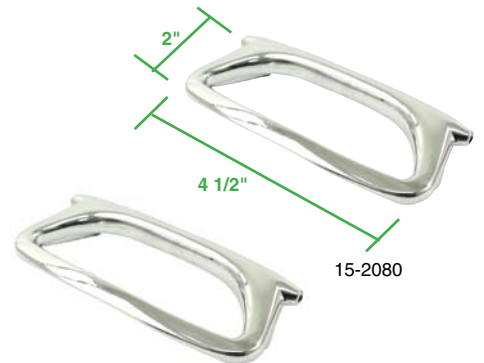

## STOCK REPLACEMENT GRAB HANDLE

Replace your worn and faded grab handle, black in color.

- 98-1061** Grab Handle, 61-67, Each  
(Bulk P/N: 151 898 641C)



## BAMBOO PACKAGE TRAY

One of the best accessories ever made, this tray fits under the dashboard of a Type 1 sedan providing a handy shelf to keep all your "stuff" within easy reach. EMPI's version is true bamboo and wicker, a design that's been popular since the fifties. Fits all Type 1 sedans except Super Beetle. (Includes all necessary mounting hardware)

- 4870** Bamboo Style Tray, Type 1 Sedan (Exc. S/B)



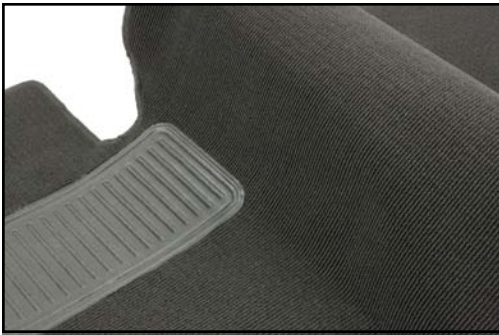

## EMPI DELUXE CARPET KITS

Our quality Deluxe Carpet Kits feature...

- Loop Carpet for comfort and noise reduction...
- Hi-count weave for superior wear and stain resistance...
- Superior backing for a easy installation and smooth, lump-free finish...
- Heavy duty heel pad - stitched in for extended wear...
- Pre-cut, bound and sewn for easy installation. Late model patterns are available for applications with and without the factory steel passenger footrest... check your VW before ordering.



### Heater Grommets....

Molded in our most popular kits - 3081, 3073 & 3980

Now that the floor, cowl and heater channel areas look great with the new carpet...Complete the 'clean' look with our Trunk and Rear Well Carpet Kits (see Page 332)

## TYPE I SEDAN CARPET KITS

- 3073** 58-68 Sedan 7-Piece w/Footrest, w/Heater Grommets, Black
- 3081** 58-68 Sedan 7-Piece w/o Footrest, w/Heater Grommets, Black
- 3910** 69-72 Sedan 7-Piece w/Footrest, Black
- 3911** 69-72 Sedan 7-Piece w/o Footrest, Black
- 3912** 73-77 Sedan, 9-Piece w/Footrest, Black
- 3913** 73-77 Sedan, 9-Piece w/o Footrest, Black



3081



3073



3912



3911



# INTERIOR ACCESSORIES

## EMPI DELUXE CARPET KITS

### TYPE I SUPER BEETLE CARPET KITS

- 3917 71-72 Super Beetle, 7-Piece w/Footrest, Black
- 3918 71-72 Super Beetle, 7-Piece w/o Footrest, Black
- 3919 73-77 Super Beetle, 9-Piece w/Footrest, Black

### TYPE I CONVERTIBLE CARPET KITS

- 3980 58-70 Bug Convertible, 7-Piece w/Footrest, w/Heater Grommets, Black
- 3981 58-70 Bug Convertible, 7-Piece w/o Footrest, Black
- 3982 71-72 Super Beetle Convertible, 9-Piece w/Footrest, Black
- 3984 73-79 Super Beetle Convertible, 11-Piece w/Footrest, Black



3917



3919



3918



3981



3982

## REAR WELL & CARGO AREA CARPET KITS

Matching carpet to cover the rear wheel well and cargo area behind the rear seat - or, with the Baja Bug Kit - carpet the rear area having taken the seat out.



3915



3997



3998

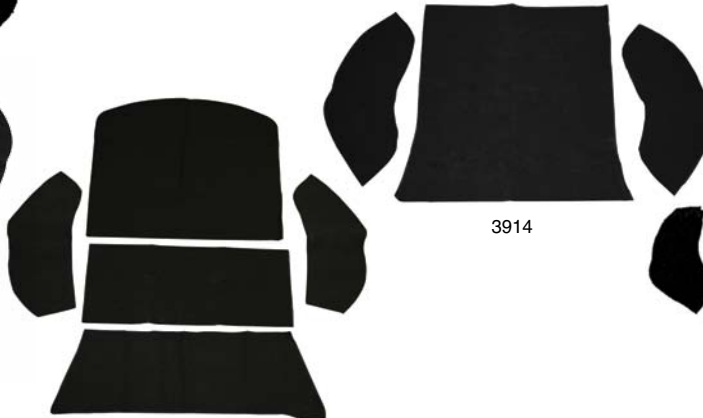

3916



3914



3075

(Rear Well Area)

**3075**

54-77 Baja Bug Sedan Rear Well Carpet Kit, 4-Piece, Black  
Covers back seat and cargo area including wheel wells when rear seat has been removed.

## TRUNK CARPET KITS

Matching carpet to cover the luggage compartment and spare tire area under the front hood. Does not include tire cover.



4285



4287



4283



4284



4286

**4283**

54-59 1/2 Bug Sedan & Conv. Trunk Carpet, 1-Piece, Black

**4284**

60-67 Bug Sedan & Conv. Trunk Carpet, 1-Piece, Black

**4285**

68-78 Bug Sedan & 68-70 Conv. Trunk Carpet, 1-Piece, Black

**4286**

71-72 Super Beetle Sedan & Conv. Trunk Carpet, 2-Piece, Black

**4287**

73-79 Super Beetle Sedan & Conv. Trunk Carpet, 2-Piece, Black



# INTERIOR ACCESSORIES

## METAL REPLACEMENT FLOOR PANELS

Don't install your new carpet kit over dangerous, old rusted-out floors! Metal replacement floor panels make it fast and easy to make repairs. Requires cutting, fitting and welding. Fits Type 1 all years, not Superbeetle.

(All panels are without seat rails)

- 3550** Front Floor Panel, w/o Seat Rails, Left, Ea  
(Ref. P/N: 111 701 059Q)
- 3551** Front Floor Panel, w/o Seat Rails, Right, Ea  
(Ref. P/N: 111 701 060Q)
- 3552** Rear Floor Panel, Left, Ea  
(Ref. P/N: 112 701 063Q)
- 3553** Rear Floor Panel, w/Battery Bracket, Right, Ea  
(Ref. P/N: 112 701 064Q)

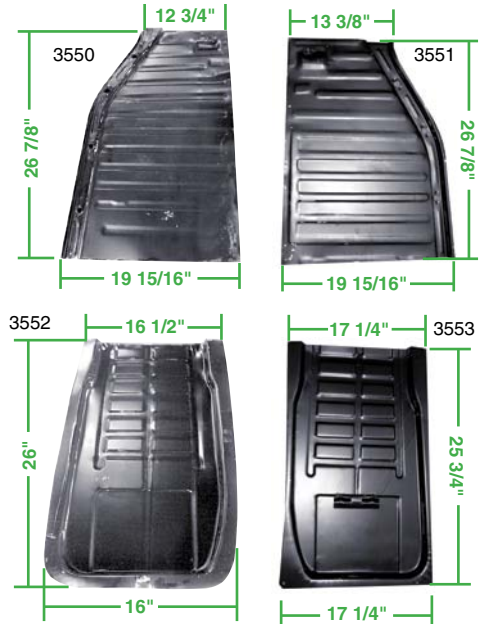

## FLOOR PAN INSTALLATION KIT

All of the Bolts and Pan Washers needed to replace one pan half. Requires 2 kits per car.

- 3554** Bolts and Pan Washers for one pan half, Set.  
(Bulk P/N: 111 898 061)



## EMPI FLOOR MATS

Another EMPI Original! Durable floor mats featuring the EMPI Logo in blue & white. Fits all Bugs.

- 15-1099** EMPI Floor Mats w/Blue & White Logo, Front, Pair
- 15-2000** EMPI Floor Mats w/Blue & White Logo, Rear, Pair  
(Makes a Great Sales Counter Mat!)

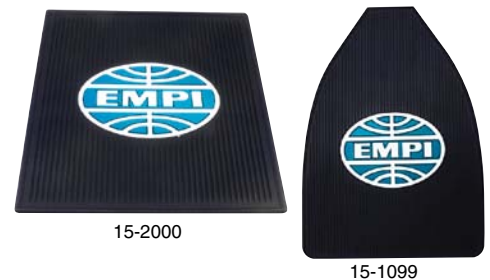

## LADY BUG FLOOR MATS

A real "Blast From the Past"! Durable floor mats with Colorful Lady Bug Logo. Fits all Bugs.

- 15-1097** Lady Bug Floor Mats, Colored, Front, Pair
- 15-1098** Lady Bug Floor Mats, Colored, Rear, Pair





## FLOOR TAR-BOARDS

Stock replacement Tar Boards for insulation. 5mm thick. Fits all years, Bugs.

**98-2012** Tar Boards, Set of 4 (Boxed)  
(Bulk P/N: 113 898 740, 4 Pieces)



TOP



BOTTOM

5" Dia. Holes (Wood Only)

## REAR SPEAKER SHELF

This popular accessory mounts behind the rear seat. It has cut-outs for speakers and is covered in heavy duty black vinyl on a wood sub-structure. Also provides concealed storage to keep valuable possessions out of eyesight. Fits all Bug models (Exc. Convertibles).

**4851** Rear Shelf  +

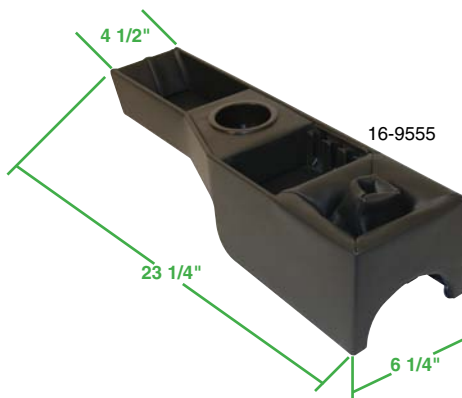

## CENTER CONSOLE

**16-9555** Type 1 68-79 Sedan / Convertible  
Sturdy black vinyl covered wood. Shift boot and cupholder combined with two convenient storage compartments add up to functional great looks.

## KICK PANEL SET

Rear kick panels for sedans 60-74. Black vinyl covered panels fit underneath the frame of the rear seat and seals the passenger compartment from the battery area and opposite side. Cutouts for heater are included.



98-8973-B

**98-8973-B** Kick Panel Set, Left & Right, Black  
(Ref. P/N: 113 898 376A)



# INTERIOR ACCESSORIES

## BUG SPEAKER KICK PANELS

Black plastic front quarter kick panels are molded for speaker installation. Easy to trim and install. Fits all Bug models (Exc. Convertibles and S/B).

4850 Front Speaker Kick Panels, Pair



## REPLACEMENT DASHES

Manufactured from molded urethane to look just like original but is even more durable. Not just a dash overlay, a must for the restoration of your VW.

4435 Replacement Dash, Bug, 68-70  
(Ref. P/N: 113 857 051A)

4436 Replacement Dash, Bug, 71-76, 71-72 S/B  
(Ref. P/N: 113 857 051DS)

4441 Replacement Dash, Type 3, 64-73

4437 **NEW!** Replacement Dash, Ghia, 58-67

4438 **NEW!** Replacement Dash, Ghia, 68-69

4439 **NEW!** Replacement Dash, Ghia, 1970

4440 **NEW!** Replacement Dash, Ghia, 71-74



4435



4436



4441



4437 **NEW!**



4438 **NEW!**



4439 **NEW!**



4440 **NEW!**

## REPLACEMENT KNEE PADS

Replacement Ghia under dash knee pads.

4676 **NEW!** Replacement Knee Pads, Ghia, 68-71

4677 **NEW!** Replacement Knee Pads, Ghia, 72-74



4676 **NEW!**



4677 **NEW!**

## DASH COVER

Black plastic dash cover installs over the top of your old cracked dash pad. Installs in minutes and can be painted if desired. Fits Super Beetle & Convertible.

4447 Dash Cover, S/B & Convertible, 73-79  +



4447



## HEADLINER KITS

Features original stock style vinyl and comes complete with door post covers. Sunroof material is available if needed. Fits Type 1 & S/B Sedans.

- |             |                               |
|-------------|-------------------------------|
| <b>4391</b> | Headliner Kit, 58-67, Ivory   |
| <b>4394</b> | Headliner Kit, 58-67, Black   |
| <b>4392</b> | Headliner Kit, 68-77, Ivory   |
| <b>4395</b> | Headliner Kit, 68-77, Black   |
| <b>4396</b> | Sunroof Material, Bulk, Ivory |
| <b>4397</b> | Sunroof Material, Bulk, Black |

## INTERIOR LIGHT

Stock replacement Interior Light.



- |                |  |
|----------------|--|
| <b>98-1089</b> | Push-on terminals, 1970-77 Type 1 (Exc. Convertible).<br>Will fit 52-69 but will not have the OE look.<br>(Bulk P/N: 111 947 111E) |
|----------------|--|

## GLOVE BOXES

Replace your stock cardboard glove box with this durable black plastic glove box.



- |               |   |
|---------------|---|
| <b>3580-B</b> | Glove Box, Type 1, 52-57<br>(Ref. P/N: 111 857 101D)      |
| <b>3581-B</b> | Glove Box, Type 1, 58-64<br>(Ref. P/N: 111 857 101F)      |
| <b>3582-B</b> | Glove Box, Type 1, 65-67<br>(Ref. P/N: 111 857 101H)      |
| <b>3583-B</b> | Glove Box, Type 1, 68 & Later<br>(Ref. P/N: 111 857 101K) |
| <b>3584-B</b> | Glove Box, Type 2, 68 & Later<br>(Ref. P/N: 211 857 101A) |
| <b>3564-B</b> | Glove Box, Karmann Ghia, All<br>(Ref. P/N: 141 857 101C)  |

## HIDDEN STEREO GLOVE BOX

A glove box made with a built in area to mount your stereo. Perfect for applications where security is an issue or when modifications to the stock dash are not desired. Made of durable black plastic.

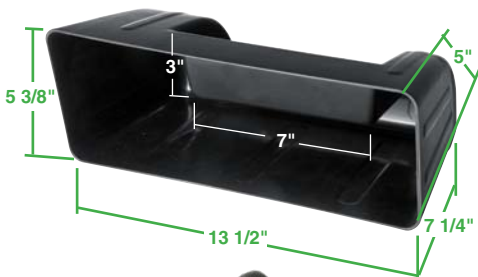

- |             |  |
|-------------|--|
| <b>3033</b> | Hidden Stereo Glove Box, Type 1, 58-64 |
|-------------|--|

## RUBBER BUMPER

Rubber stop for glove compartment lid or fuel filler door. For Type 1 52-77, Ghia 56-74, Type 2 68-79 and Type 3 64-73.



- |                  |  |
|------------------|--|
| <b>98-0120</b>   | Rubber Bumper (2 pcs. Skinpacked)                    |
| <b>98-0120-8</b> | Bulk Rubber Bumper (100 pcs.)                        |
| <b>98-0120-B</b> | Bulk Rubber Bumpers (Each)<br>(Ref. P/N: N020 029 1) |





# INTERIOR ACCESSORIES

## **UNDER DASH STEREO / GAUGE PANEL**

Molded accessory panel mounts to the underside of the bug dashboard ashtray area providing extra room to mount your stereo, gauges, switches or anything else you want to mount and don't want to modify the stock dash to do it. Made of durable black plastic.

**3034** Under Dash Stereo / Gauge Panel



## **GLOVE BOX LOCKS**

Protects your belongings in the glove box!

**98-1054** Glove Box Lock, 68-77 Bug, 71-72 S/B  
(Bulk P/N: 133 857 131)



98-1054

## **SUN VISORS & CLIPS**

Replace your worn or faded sun visors with these quality stock-style visors. Sold in pairs.

### **TYPE 1 BUG & CONVERTIBLE**

- 4425** Sun Visors, 58-64, Ivory, Pair
- 4426** Sun Visors, 58-64, Black, Pair
- 4423** Sun Visors, 65-77 Bug, 73-79 Conv., Ivory, Pair
- 4424** Sun Visors, 65-77 Bug, 73-79 Conv., Black, Pair
- 4400** Sun Visors, 65-72 Conv., Ivory, Pair
- 4401** Sun Visors, 65-72 Conv., Black, Pair

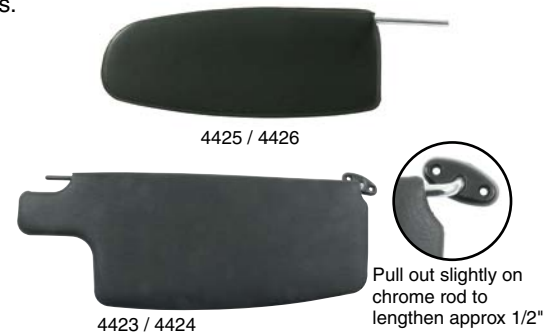

4425 / 4426

4423 / 4424

### **TYPE 2 BUS**

**4421** Sun Visors, 68-79, Ivory, Pair



4400 / 4401

### **VISOR CLIPS**

- 4429** Sun Visor Clips, Type 1, 65-67, Type 2, 68-79, Ivory, Pair  
(Bulk P/N: 111 857 561W, Pair)
- 4430** Sun Visor Clips, Type 1, 65-67, Type 2, 68-79, Black, Pair  
(Bulk P/N: 111 857 561B, Pair)
- 4427** Sun Visor Clips, Type 1, 68-79, Ivory, Pair  
(Bulk P/N: 133 857 561W, Pair)
- 4428** Sun Visor Clips, Type 1, 68-79, Black, Pair  
(Bulk P/N: 133 857 561B, Pair)



4421

4430

4428

## INSIDE REAR VIEW MIRRORS

Quality OEM-Style replacement rear view mirrors for VW Sedans. Polished chrome finish.



**98-8577** Rear View Mirror, Type 1 Sedan, thru 57  
(Bulk P/N: 113 857 511) Chrome Plated Metal

**98-8580** Rear View Mirror, O.E. Style  
Type 1 Sedan, 58-64, Chrome Plated Metal  
(Bulk P/N: 113 857 511A)

**98-8578** Rear View Mirror, O.E. Style  
Type 1 Sedan, 65-67, Chrome Plated Metal  
(Bulk P/N: 111 857 511B)

**98-8579**  Rear View Mirror, Black Plastic, Type 1 Sedan, 68-on, Day/Nite  
Metal Coated with Black Plastic  
(Bulk P/N: 113 857 511L)

## STOCK REPLACEMENT VENT WING LOCKS

Replace old or broken vent wing locks. Fits Type 1 & S/B.



**98-1043** Vent Wing Lock, Left, Type 1, 52-64 & Convertible, 52-67  
(Bulk P/N: 113 837 639A)

**98-1044** Vent Wing Lock, Right, Type 1, 52-64 & Convertible, 52-67  
(Bulk P/N: 113 837 640A)

**98-1045** Vent Wing Lock, Left, 68-77 (Sedan Only)  
(Bulk P/N: 111 837 657A)

**98-1046** Vent Wing Lock, Right, 68-77 (Sedan Only)  
(Bulk P/N: 111 837 658A)

## UNIVERSAL VENT LOCKS

Simple to install, these Vent Locks fit most any car with a vent window. Chrome plated with black knobs.



**9701** Universal Vent Locks, Pair



# INTERIOR ACCESSORIES

## 5-PANEL REAR VIEW MIRROR

Replaces rear view mirror and provides excellent visibility. Helps eliminate those "Blind Spots". Frame made of durable black plastic. Includes metal mounting hardware and comes in a display box with a hang tab.

- 4580 5-Panel Mirror, Complete with Hardware
- 4580-7 Replacement Hardware Kit Only for 4580

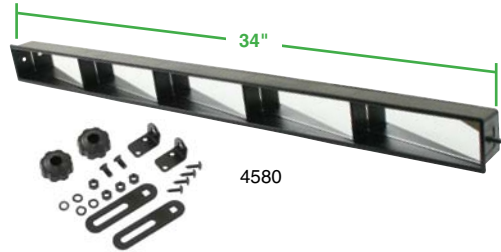

## BILLET PANEL STYLE REAR VIEW MIRROR

EMPI's Polished Billet Aluminum Multi Panel Mirrors give you a panoramic view of the world behind you. Pick the mirror size that's right for you. Then choose the Mounting Bracket that works best for your application.

- 16-8580 Aluminum 3-Panel R/V Mirror, 18" Wide
- 16-8581 Aluminum 4-Panel R/V Mirror, 24" Wide
- 16-8582 Aluminum 5-Panel R/V Mirror, 30" Wide

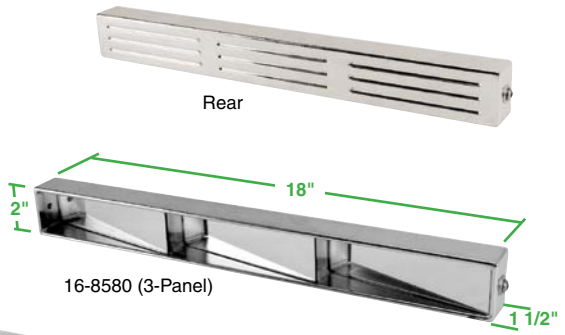

- 16-8585 Aluminum Mirror Mount, 1 1/2" Radius, Pair
- 16-8587 Aluminum Mirror Mount, Flat, Pair
- 16-8586 Aluminum Mirror Mount, Clamp on for 1 1/2" Tubing, Pair



## **BILLET ALUMINUM "VINTAGE LOOK" INTERIOR ITEMS**

Give your ride that "resto-custom" look with these great looking 6061-T6 billet aluminum handles, knobs, buffer rings, etc. Made to look like an original vintage item but milled from solid billet aluminum. The door/window winder buffer rings and the door pull knobs are polished while the rest of the knobs are a machined finish that gives you just the right contrast and looks. Most items are sold in per car quantity's, see below.



11-4531

**11-4531** Billet Knob Window Cranks, Type 1, thru 66, Pair  
(Chrome Metal Arm w/Billet Knobs)



11-4532

**11-4532** Billet Buffer Rings, Type 1, thru 66, Set of 4



11-4533

**11-4533** Billet E-Brake Button, All Years



11-4536

**11-4535** Billet Dash Knob, 5mm, Each



11-4538

**11-4536** Billet Radio Knobs, Push-on, Pair



11-4539

**11-4537** Billet Heater Knob, Type 1, thru 64



11-4535

**11-4538** Billet Hood Pull Knob, Type 1, thru 68, Each



11-4540

**11-4539** Billet Shift Knob, 7/10/12mm Threads, Each



11-4537

**11-4540** Billet Door Pulls, O.E. Style, Pair



11-4541

**11-4541** Billet Seat Slider Knob, Pair



8510

## **BILLET STYLE DOOR HANDLE & WINDOW HANDLE**

Dress your VW in the machined aluminum look with these Billet style accessories.

**8508** Billet Style Door Handles, Type 1 & 3, thru 66, Pair

**8510** Billet Style Window Cranks, All Models, All Years, Pair

8508



8506

## **BILLET STYLE DOOR LOCK PULLS**

Machined aluminum style door lock pulls threaded to replace stock originals.

**8506** Billet Style Door Lock Pulls, 67-79, Pair



# INTERIOR ACCESSORIES

## DOOR HANDLES & WINDOW HANDLES

Custom handles add to that custom interior look. Chrome with hard Black plastic knobs.

- 11-4519-B Door Handles, thru 66, Pair
- 11-4520-B Window Cranks, thru 67, Pair
- 11-4521-B Window Cranks, 68 & Later, Pair



## DOOR LOCK PULLS

Chrome Shaft with black tip. A perfect match to our custom door and window handles.

- 11-4510-B Door Lock Pulls, Black, 67-79, Pair



## DOOR/WINDOW HANDLE TENSION SPRING

Replace your fatigued or lost Door & Window Handle tension Spring with a new one. Fits between the door panel and inner door.

- 98-8338 Door/Window Handle Tension Spring, Type 1 All, Each  
(Bulk P/N: 111 837 229C)



## STOCK STYLE DOOR & WINDOW HANDLES & BUFFERS

Replacement handles for early and late Type 1 VW's.

- 98-1039 Door Handle, Chrome, 56-66, Each  
(Bulk P/N: 113 837 225A, Each)
- 98-1041 Window Crank, Black, 75-79, Each  
(Bulk P/N: 321 837 581, Each)
- 98-1042 Window Crank, H.D., Black, 68-74, Each  
(Bulk P/N: 111 837 581J, Each)
- 98-1069 Window Crank, 56-67, Ivory Knob, Each  
(Bulk P/N: 113 837 581E, Each)
- 98-1070 Window Crank, 56-67, Black Knob, Each  
(Bulk P/N: 113 837 581EB, Each)
- 98-2040 Window Handle Buffer, 56-67, Black, Pair  
(Bulk P/N: 113 837 235A, Each)
- 98-2041 Window Handle Buffer, 56-67, Ivory, Pair  
(Bulk P/N: 111 837 235AIV, Each)
- 98-0117 Retaining Pins for Window Crank/Door Handle,  
Type 1, thru 67 (4 pcs.)  
(Bulk P/N: N012 810 1, Each)





98-2035



98-2036



98-2042



98-2043



98-2091



98-2092



98-2093



98-2095



98-2097



98-2099



4577



4578



4579



## COAT HOOKS, ASSIST STRAPS, LOCK KNOBS, SEALS

Replace old or missing coat hooks, door lock knobs, grab handles, seals, plugs and other small but important parts that make a detailed finish in your VW Bug's interior.

**98-2035** Door Switch Seals, Black, Pair  
(Bulk P/N: 113 947 565A, Each)

**98-2036** Door Check Rod Seals, Black, Pair  
(Bulk P/N: 111 837 267A, Each)

**98-2042** Door Hinge Screw Plugs, Clear Plastic, Set of 4  
(Bulk P/N: 111 831 449A, Each)

**98-2043** Door Hinge Oil Hole Plugs, Black, Set of 4  
(Bulk P/N: 311 831 439A, Each)

**98-2091** Door Lock Knobs, Black, All Air Cooled, Pair  
(Bulk P/N: 111 837 187B, Each)

**98-2092** Door Lock Knobs, Black, H2O Cars, Pair  
(Bulk P/N: 191 837 187, Each)

**98-2093** Assist Straps, Bug 58-67, Black, Pair  
(Bulk P/N: 113 857 611B, Each)

**98-2094** Assist Straps, Bug 58-67, White, Pair  
(Bulk P/N: 113 857 611BW, Each)

**98-2095** Assist Straps, Bug 68-77, Black, Pair  
(Bulk P/N: 113 857 611E, Each)

**98-2096** Assist Straps, Bug 68-77, White, Pair  
(Bulk P/N: 113 857 611EW, Each)

**98-2097** Coat Hooks, Bug 61-67, Black, Pair  
(Bulk P/N: 113 857 637A, Each)

**98-2098** Coat Hooks, Bug 61-67, White, Pair  
(Bulk P/N: 113 857 637AW, Each)

**98-2099** Coat Hooks, Bug 68-77, Black, Pair  
(Bulk P/N: 113 857 637B, Each)

**98-2100** Coat Hooks, Bug 68-77, White, Pair  
(Bulk P/N: 113 857 637BW, Each)

## DOOR TRIM COVERS

Highly polished trim adds beauty and protection to door pillar, sill and corner. Fits all Type 1 Sedans, thru 79.

**4577** Door Corner Trim Set, [Stainless Steel](#), Pair

**4578** Door Pillar Trim Set, [Stainless Steel](#), Pair

**4579** Door Sill Cover Set, [Aluminum](#), w/EMPI Pressed into it, Pair (Boxed)



# INTERIOR ACCESSORIES

## EMPI LOGO GEAR SHIFT KNOBS

EMPI gear shift knobs are covered in quality vinyl and available in black or brown. Triple Threaded knobs (7, 10 and 12mm) fit all VW models. All of these feature Epoxy Style EMPI Logo.

- 4540 Shift Knob, Black Vinyl
- 4542 Shift Knob, Brown Vinyl



4540

## SHIFT PATTERN GEAR SHIFT KNOBS

Just like our EMPI logo shift knobs, these knobs feature an epoxy shift pattern and are triple threaded (7, 10 & 12mm) to fit all VW models, 4 Speed with reverse lower left.

- 79-4640 Shift Knob, Black Vinyl
- 79-4642 Shift Knob, Brown Vinyl



79-4640

## BILLET ALUMINUM SHIFT KNOBS

Get a grip! Give your stock shifter a high tech look with a Billet Aluminum Shift Knob. Features a stepped triple thread system to fit all 7, 10 and 12mm shift levers.

- 79-5051 Billet Aluminum Round Style Shift Knob  
7, 10 and 12mm threads.
- 79-5052 Billet Aluminum Shift Knob, 3/8-24 threads, Round  
(for P/N: 4449, 4450, 4451 Trigger Shifters)



79-5051/79-5052

## BILLET ALUMINUM E-BRAKE COVER

The finishing touch to any custom or stock interior. Installs over stock E-brake handle and is held in place with set screws. Fits all VW models including Water Cooled.

- 11-4542 Billet Style E-Brake Cover



11-4542

## BILLET ALUMINUM DASH BOARD

These are available in 9 different styles, and each style is available with satin or chrome finish. All of the large holes are 3 1/8" ID. All of the small holes are 2 1/16" ID. Dash Panels are drilled and tapped 6mm - 1.0 on the back side for mounting.

- 16-9818 Billet Dash, 1 Sm., 1 Lg., 1 Sm., Aluminum, Each
- 16-9819 Billet Dash, 1 Sm., 1 Lg., 1 Sm., Chrome, Each
- 16-9820 Billet Dash, 2 Sm., 1 Lg., 2 Sm., Aluminum, Each
- 16-9821 Billet Dash, 2 Sm., 1 Lg., 2 Sm., Chrome, Each
- 16-9822 Billet Dash, 1 Lg., 2 Sm., Aluminum, Each
- 16-9823 Billet Dash, 1 Lg., 2 Sm., Chrome, Each
- 16-9824 Billet Dash, 1 Lg., 3 Sm., Aluminum, Each
- 16-9825 Billet Dash, 1 Lg., 3 Sm., Chrome, Each
- 16-9826 Billet Dash, 1 Lg., 4 Sm., Aluminum, Each
- 16-9827 Billet Dash, 1 Lg., 4 Sm., Chrome, Each
- 16-9828 Billet Dash, 2 Lg., 4 Sm., Aluminum, Each
- 16-9829 Billet Dash, 2 Lg., 4 Sm., Chrome, Each
- 16-9831 Billet Dash, 2 Sm., 2 Lg., 2 Sm., Chrome, Each
- 16-9832 Billet Dash, 3 Small, Aluminum, Each
- 16-9833 Billet Dash, 3 Small, Chrome, Each
- 16-9834 Billet Dash, 4 Small, Aluminum, Each
- 16-9835 Billet Dash, 4 Small, Chrome, Each

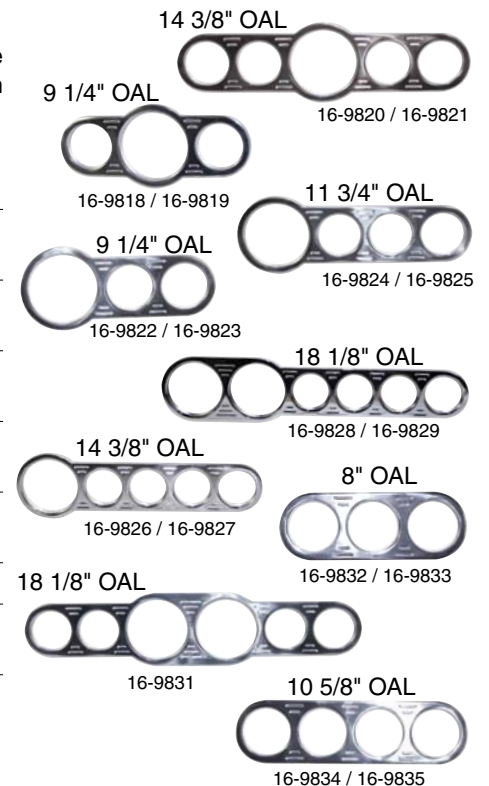

14 3/8" OAL

9 1/4" OAL

16-9820 / 16-9821

16-9818 / 16-9819

11 3/4" OAL

9 1/4" OAL

16-9824 / 16-9825

16-9822 / 16-9823

18 1/8" OAL

16-9828 / 16-9829

14 3/8" OAL

8" OAL

16-9826 / 16-9827

16-9832 / 16-9833

18 1/8" OAL

16-9831

10 5/8" OAL

16-9834 / 16-9835

## GRANT STEERING WHEELS

In 1962 Grant introduced their first Steering Wheel for dune buggies. Grant offers fine quality products with distinctive style, solid value and a wide selection of designs to express your individual personality. First dish dimension is given by Grant. The second dimension is from wheel face to hub face.

See page 348 for adapter kits.



79-4031

79-4030

### GT Sport Thick Foam Wheels

Thick textured foam hand grip. Available in matte black or chrome steel spokes and comes with a matte black styling sleeve.

**79-4030**

GT Sport Thick Foam, Black Spoke, 13" Dia., 3.50" Dish / 4 1/8"

**79-4031**

GT Sport Thick Foam, Chrome Spoke, 13" Dia., 3.50" Dish / 4 1/8"



79-4033

79-4032

79-4034

### GT Rally Wheels

Molded black polyurethane grip with silver or black anodized aluminum spokes w/ styling sleeve.

**79-4032**

Rally GT, Black 3-Spoke, 13" Dia., 3" Dish / 3 3/8"

**79-4033**

Rally GT, Silver, 3-Spoke, 13" Dia., 3" Dish / 3 1/4"

**79-4034**

Rally GT, Black 4-Spoke, 14" Dia., 3 3/4" Dish / 3 1/2"

**79-4035**

Rally GT, Silver 4-Spoke, 14" Dia., 3 3/4" Dish / 3 3/4"



79-4039

79-4038

79-4037

### Formula GT Wheels

Black hand stitched leather grained vinyl grip with black or silver anodized or highly polished aluminum spokes w/styling sleeve.

**79-4036**

Formula GT, Black 3-Spoke, 13" Dia., 3" Dish / 3 1/2"

**79-4038**

Formula GT, Black, 3-Spoke, 12" Dia., 3" Dish / 3 3/4"

**79-4037**

Formula GT, Polished, 3-Spoke, 13" Dia., 3" Dish / 3 3/8"

**79-4039**

Formula GT, Silver, 3-Spoke, 11 3/4" Dia., 3" Dish / 3 1/2"



79-4040

79-4041

### Formula 1 Racing Wheels

Black suede leather with black or silver anodized aluminum spokes, 3 spoke design.

**79-4040**

Formula 1, Black, 3-Spoke, 10" x 9" (D-Shape) diameter

**79-4041**

Formula 1, Silver, 3-Spoke, 10" x 9" (D-Shape) diameter

Mounting holes must be drilled. NOT FOR STREET USE.



79-4014

79-4047

79-4050

79-4052

79-4051

### Classic Foam Wheels

Black foam cushion grip with chrome spokes. Adapters are available to install steering wheels on various VW models, see page 348. The standard 3 bolt pattern is the same as our P/N: 3172 and P/N 16-9567 steering wheel quick disconnects and P/N: 3177 and P/N 17-2579 steering shafts.

See page 348 for adapter kits.

**79-4014**

Classic Foam, Chrome, 4 spoke, 11 1/2" dia., 3 3/4" dish / 3 3/4"

**79-4047**

Classic Foam, Chrome, 4 spoke, 13" dia., 1 3/4" dish / 2"

**79-4050**

Classic Foam, Chrome, 3 spoke, 8 1/2" dia., 4 1/2" dish / 5 1/4"

**79-4051**

Classic Foam, Chrome, 3 spoke, 11 1/2" dia., 3 3/4" dish / 3 3/4"

**79-4052**

Classic Foam, Black, 3 solid spoke, 10 1/4" dia., 2 1/2" dish / 2 7/8"





# INTERIOR ACCESSORIES

## EMPI POLISHED BILLET ALUMINUM STEERING WHEEL BOSS KITS

EMPI Polished Billet Aluminum Steering Wheel Boss Kits allow the installation of [most](#) 3-Bolt (Grant/Pip-Style) steering wheels. Includes 2 logo's.

- 79-4024 **NEW!** EMPI Polished [Billet Aluminum](#) Steering Wheel Boss Kit Only Fits Type 1 Bug & Ghia 49-59
- 79-4025 EMPI Polished [Billet Aluminum](#) Steering Wheel Boss Kit Only Fits Type 1 Bug & Ghia 60-74 1/2, Type 3 61-71
- 79-4056 **NEW!** EMPI Polished [Billet Aluminum](#) Steering Wheel Boss Kit Only Fits Type 2 55-67
- 79-4057 **NEW!** EMPI Polished [Billet Aluminum](#) Steering Wheel Boss Kit Only Fits Type 2 68-73
- 79-4058 **NEW!** EMPI Polished [Billet Aluminum](#) Steering Wheel Boss Kit Only Fits Type 2 74-79

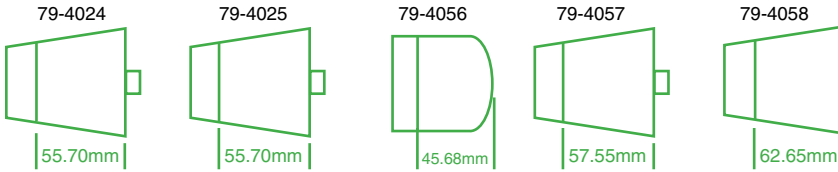

## STEERING WHEEL ADAPTER KITS

For Volkswagen

- 79-4019 Adapter Kit, Two inch extension, 3 hole to 3 hole
- 79-4018 Adapter Kit, One inch [Aluminum](#) extension, 5 hole to 3 hole
- 79-4020 Adapter Kit, Two inch [Aluminum](#) extension, 5 hole to 3 hole



## BILLET STEERING WHEELS

Let EMPI steer you in the right direction with a billet aluminum steering wheel. Function and style are combined to make a steering wheel capable of withstanding harsh off-road elements that leave conventional wheels falling apart in your hands. Available in two designs to suit your individual taste.

- 16-8100 10" Polished [Aluminum](#) "Batwing" Steering Wheel
- 16-8102 10" Polished [Aluminum](#) "Vortex" Steering Wheel
- 16-8105 [Billet Aluminum](#) Hub Cover, All Wheels



## BILLET ALUMINUM STEERING WHEEL ADAPTER

16-9815 captures the steering wheel between the 2 halves. This unit has no horn button.

- 16-9815 5 Hole to 3 Hole Steering Wheel Adapter, Front Mount, 2 pc Kit



## EMPI CLASSIC WOOD STEERING WHEELS

Beautiful Classic Wood with Polished Chrome Spokes. Real Wood Grain finished with finger grips on the under-side. 380mm diameter with Phat 31mm grip or standard 23mm grip. Both feature a 2 1/2" Dish with Classic 3-Bolt Hub Pattern. Available in light or dark wood. Kits include Polished Billet Aluminum Boss with horn button and 2 logo's. Kits fit Type 1 Bug & Ghia 60-74 1/2 and Type 3 61-71. Steering Wheels and Boss kits may be purchased separately.

- |  |                       |  |
|--|-----------------------|--|
|  | 79-4026               | EMPI 380mm/31mm Grip Classic Wood Steering Wheel w/Boss<br>Fits Type 1 Bug & Ghia 60-74 1/2, Type 3 61-71      |
|  | 79-4026-7             | EMPI 380mm/31mm Grip Classic Wood Steering Wheel Only<br>3" Dish with Classic 3-Bolt Hub Pattern               |
|  | 79-4021 <b>NEW!</b>   | EMPI 380mm/31mm Grip Dark Classic Wood Steering Wheel w/Boss<br>Fits Type 1 Bug & Ghia 60-74 1/2, Type 3 61-71 |
|  | 79-4021-7 <b>NEW!</b> | EMPI 380mm/31mm Grip Dark Classic Wood Steering Wheel Only<br>3" Dish with Classic 3-Bolt Hub Pattern          |
|  | 79-4028               | EMPI 380mm/23mm Grip Classic Wood Steering Wheel w/Boss<br>Fits Type 1 Bug & Ghia 60-74 1/2, Type 3 61-71      |
|  | 79-4028-7             | EMPI 380mm/23mm Grip Classic Wood Steering Wheel Only<br>3" Dish with Classic 3-Bolt Hub Pattern               |
|  | 79-4021 <b>NEW!</b>   |  |
|  | 79-4022 <b>NEW!</b>   | EMPI 380mm/23mm Grip Dark Classic Wood Steering Wheel w/Boss<br>Fits Type 1 Bug & Ghia 60-74 1/2, Type 3 61-71 |
|  | 79-4022-7 <b>NEW!</b> | EMPI 380mm/23mm Grip Dark Classic Wood Steering Wheel Only<br>3" Dish with Classic 3-Bolt Hub Pattern          |
|  | 79-4028-7             |  |
|  | 79-4025               | EMPI Polished Billet Aluminum Steering Wheel Boss Kit Only<br>Fits Type 1 Bug & Ghia 60-74 1/2, Type 3 61-71   |
|  | 79-4024 <b>NEW!</b>   | EMPI Polished Billet Aluminum Steering Wheel Boss Kit Only<br>Fits Type 1 Bug & Ghia 49-59                     |





# INTERIOR ACCESSORIES

## EMPI TYPE 2 CLASSIC WOOD STEERING WHEEL

Beautiful 457mm diameter Classic Wood Steering Wheel with Polished Chrome 3-Spoke design with finger grips on the under-side and a 1 1/2" Dish. Big and Beefy 31mm grip designed to enhance the look of any Bus or Transporter. Wheel only – purchase your Billet Adapter to complete the installation.



**NEW!**



31mm Grip

79-4055-6 **NEW!** 457mm Type 2 Wood Steering Wheel Only

## EMPI TYPE 2 POLISHED BILLET ALUMINUM STEERING WHEEL BOSS KITS

Polished Billet Aluminum Wheel Boss Kits for all Bus and Transporter applications will mount your EMPI Classic Wood Steering wheel with style. Includes 2 logo's. See page 345 for dimensions of all hubs.

79-4056 **NEW!** EMPI Polished Billet Aluminum Steering Wheel Boss Kit Only Fits Type 2 55-67

79-4057 **NEW!** EMPI Polished Billet Aluminum Steering Wheel Boss Kit Only Fits Type 2 68-73

79-4058 **NEW!** EMPI Polished Billet Aluminum Steering Wheel Boss Kit Only Fits Type 2 74-79

**NEW!**



79-4056

**NEW!**



79-4057

**NEW!**



79-4058



## EMPI POLY-FOAM STEERING WHEELS

Featuring a thick, textured black Poly-Foam grip with Chrome spokes and is available in a range of sizes. Standard 3-Bolt mounting pattern for use with Steering Wheel Adapters, Quick Disconnects (P/N 3172 & P/N 16-9567) or Steering Shafts (P/N 3177 & P/N 17-2579).

**Note: Does not come with Horn Button – sold in Adapter Kit.**

- 79-4110** EMPI Poly-Foam Steering wheel, 3 spoke, 13 1/2" Dia., 3 1/2" Dish / 3 1/2"
- 79-4111** EMPI Poly-Foam Steering wheel, 3 spoke, 10" Dia., 5 1/2" Dish / 5 1/2"
- 79-4112** EMPI Poly-Foam Steering wheel, 3 spoke, 12 1/2" Dia., 3 1/2" Dish / 3 1/2"
- 79-4113** EMPI Poly-Foam Steering wheel, 3 solid spoke, 14 3/4" Dia., 4" Dish / 4 1/4"



## EMPI STEERING WHEEL ADAPTERS

For EMPI and other popular 3-bolt steering wheels. Features Chrome Horn Button that is recessed for use with or without EMPI Logo, 3 logos supplied.



- 79-4115** EMPI Steering Wheel Adapter Kit, Type 1 Bug and Ghia, 60-74 1/2, I.D. Spline Area .795, O.D. Spine Area .835, 40 Splines

- 79-4117** EMPI Steering Wheel Adapter Kit, Fits All VW's 75-88, I.D. Spline Area .652, O.D. Spine Area .680, 40 Splines (Exc. 75 1/2-77 Dasher)

- 79-4116** **NEW!** EMPI Steering Wheel Adapter Kit, Type 1 Bug 49-59, I.D. Spline Area .863, O.D. Spine Area .982, 24 Splines





# ELECTRICAL ACCESSORIES

## HEADLIGHT ASSEMBLIES / RETAINERS & RIMS

Replace rusted and damaged assemblies or retainers with our high quality headlight units.

### EARLY HEADLIGHT COMPONENTS

**98-1063-B** Headlight Assembly, Type 1 & 2, thru 66, Each  
(Ref. P/N: 111 941 037C)

**98-2059** Headlight Rim, Chrome, Type 1 & 2  
(Bulk P/N: 111 941 111) **Adjusting Screws at 5 & 7 O'Clock**

**98-2060** Headlight Rim, Chrome, Type 1 & 2  
(Bulk P/N: 111 941 111B) **Adjusting Screws at 2 & 7 O'Clock**

**98-9411-B** Gasket, Headlight Lens, Type 1 50-66, Type 2 50-67, Grey, Each  
(Ref. P/N: 111 941 119)

**98-9414-B** Gasket, Headlight Assembly, Type 1 50-66, Type 2 50-67, Each  
(Ref. P/N: 111 941 191)



98-1063-B



98-2060



98-9411-B

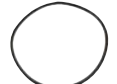

98-9414-B



98-1064



9479

### LATE HEADLIGHT COMPONENTS

**98-1064** Headlight Retaining Unit, 67-79, Each  
(Bulk P/N: 141 941 041) Compatible with H4 Headlight

**9479** Headlight Rims, Chrome, 67-79, Pair  
(Bulk P/N: 311 941 177, Each)

**16-2102** H.D. 3-Prong Headlight Pigtail / Connector



16-2102

## 7" H4 HEADLIGHT CONVERSIONS

Add the vision and safety of Halogen. Replace your 7" round sealed beams with these H4 Halogen conversion kits. Comes with 12-Volt H4 55/60 watt bulb. Bulb is replaceable.

**9311** 7" H4 Headlight - Round, Each  
Will Fit P/N: 9307-7 and P/N 98-1064-B



9311



## 7" SEALED BEAM HI/LOW BULB

12-Volt round 7" sealed beam Hi/Low Replacement head light bulb.

**9304** **NEW!** 7" Sealed Beam Hi/Low Bulb Only, Each (Boxed)



9304 **NEW!**

## REPLACEMENT BULBS

EMPI offers a complete line of halogen headlight bulbs to fit most any application. Pick the style that fits your light and then choose the wattage best suited for your driving conditions. Be sure to check the vehicle's charging capacity to avoid overloading the system (watts ÷ volts = amps). Check your local laws regarding wattage and color for street applications. [See page 415 for H1, H2 and H3 Bulbs](#)

**16-9168** Ultra Cool Clear White Light, H4 12V 60/55W, Clear, Each

**16-9170** Ultra Cool Gold White Light, H4 12V 60/55W, Gold, Pair

**16-9173** Ultra Cool Gold White Light, H4 12V 100/55W, Gold, Pair

**16-9176** Ultra Cool Gold White Light, H4 12V 130/100W, Gold, Pair



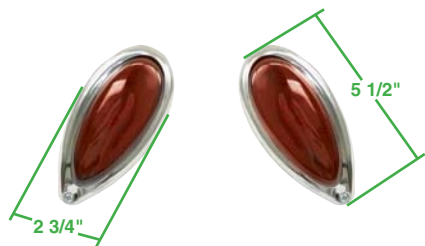

## TEARDROP TAIL LIGHTS

Add that Custom 50's Look to your Bug or Bus. Each assembly comes with a dual filament 12-Volt bulb. Requires cutting, fitting and wiring modifications.

**9490** Red Teardrop Tail Lights, Pair



## BLUE DOTS

The Ultimate 50's accessory! Fits all tail light lenses. Requires careful drilling of lens.

**9491** Blue Dot w/Chrome Ring, Pair



## STOCK STYLE LIGHT ASSEMBLIES & LENSES

Complete Light Assemblies or Lenses for Type 1 & Type 2. Tail Light Lenses available in stock Red/White or "Euro Style" Amber/Red.



## TYPE 1 FRONT TURN SIGNAL ASSEMBLIES

**98-9529** Turn Signal Assy., Left & Right, 58-63, Amber, Each (Chrome Plated Steel) (Bulk P/N: 113 953 041CA)

**98-9530** Turn Signal Assy., Left & Right, 58-63, Clear, Each (Chrome Plated Steel) (Bulk P/N: 113 953 041C)

**98-9531** Turn Signal Assy., Left & Right, 64-66, Amber, Each (Chrome Plated Plastic) (Bulk P/N: 113 953 041J)

**98-9533** Turn Signal Assy., Left, 70-79, Amber (Chrome Plated Plastic) (Bulk P/N: 113 953 041N)

**98-9534** Turn Signal Assy., Right, 70-79, Amber (Chrome Plated Plastic) (Bulk P/N: 113 953 042N)

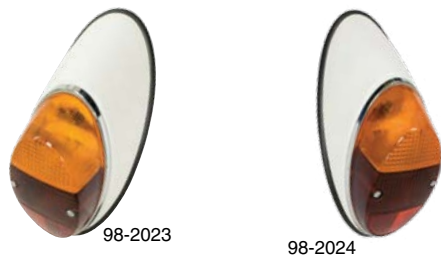

## TYPE 1 TAIL LIGHT ASSEMBLIES

**98-2023** T/L Assembly, Left, 62-67, Euro Style (Painted Metal) (Bulk P/N: 111 945 095NE)

**98-2024** T/L Assembly, Right, 62-67, Euro Style (Painted Metal) (Bulk P/N: 111 945 096NE)

**98-1091** T/L Assembly, Left, 68-70, Euro Style (Painted Metal) (Bulk P/N: 111 945 095RE)

**98-1092** T/L Assembly, Right, 68-70, Euro Style (Painted Metal) (Bulk P/N: 111 945 096RE)



**98-9455** T/L Assembly, Left, Type 1, 73-79 (Gray Plastic) (Bulk P/N: 133 945 097AK)

**98-9456** T/L Assembly, Right, Type 1, 73-79 (Gray Plastic) (Bulk P/N: 133 945 098AK)



**98-9452** T/L Assembly, Left & Right, Universal, 73-79, Each (Gray Plastic) (Bulk P/N: 133 945 097A) (Ref. P/N: 133 945 097A or 133 945 098A)

**98-9988-B** T/L Assembly, Left & Right, 73-79, Each, Hella (Ref P/N: 113 945 097/8A)



# ELECTRICAL ACCESSORIES

## TYPE 2 TAIL LIGHT ASSEMBLIES

- 98-9514** T/L Assembly, Left & Right, Red, Type 2, 62-71, Each  
(Bulk P/N: 211 945 237K)
- 98-9453** T/L Assy., Left & Right, Amber/Red/White, 72-79, Each  
(Bulk P/N: 211 945 241RA)
- 98-9989-B** T/L Assy., Left & Right, Amber/Red/White, 72-79, Each, Hella  
(Ref P/N: 211 900 145GH)



98-9514



98-9453-B



98-9989-B

## STOCK STYLE LENSES

### TYPE 1 LENSES

- 98-9501** Early H/L Lens, Left & Right, thru 66, Glass, Each  
(Bulk P/N: 111 941 115H)
- 98-9502** Early H/L Lens, Left & Right, thru 66, Cibie Style, Glass, Each  
(Bulk P/N: 111 941 115HCB)
- 98-9503** Early H/L Lens, Left & Right, thru 66, Vintage Euro Style, Glass, Each  
(Bulk P/N: 111 941 115HVN)
- 98-9505** Early H/L Lens, Left & Right, thru 66, Porsche 911 Style, Glass, Each  
(Bulk P/N: 111 941 115POR)
- 98-9638** Turn Signal Lens, Left & Right, Type 1 55-57 / Type 2 56-62, Clear, Each  
(Bulk P/N: 111 953 161)
- 98-9521** Turn Signal Lens, Left & Right, 58-63, Clear, Each  
(Bulk P/N: 113 953 161ACL)
- 98-9522** Turn Signal Lens, Left & Right, 58-63, Amber, Each  
(Bulk P/N: 113 953 161A)
- 98-9523** Turn Signal Lens, Left & Right, 64-66, Clear, Each  
(Bulk P/N: 111 953 161JCL)
- 98-9524** Turn Signal Lens, Left & Right, 64-66, Amber, Each  
(Bulk P/N: 111 953 161J)
- 98-9639** Turn Signal Lens, Left & Right, 68-69, Amber, Each  
(Bulk P/N: 111 953 161A)
- 98-9518** Turn Signal Lens, Left, Type 1, 70-79, Clear, Each  
(Bulk P/N: 113 953 161BCL)
- 98-9517** Turn Signal Lens, Left, Type 1, 70-79, Amber, Each  
(Bulk P/N: 113 953 161B)
- 98-9520** Turn Signal Lens, Right, Type 1, 70-79, Clear, Each  
(Bulk P/N: 113 953 162BCL)
- 98-9519** Turn Signal Lens, Right, Type 1, 70-79, Amber, Each  
(Bulk P/N: 113 953 162B)



98-9501

98-9502



98-9505

98-9503



98-9638



98-9521



98-9522



98-9523

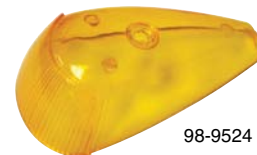

98-9524

98-9520



98-9518



98-9517



98-9639



98-9519

## STOCK STYLE LENSES (Continued)

### TYPE 1 LENSES (Continued)



- 98-1074** T/L Lens, Left & Right, 62-67, Euro Style, Each  
(Bulk P/N: 111 945 241DE)
- 98-1075** T/L Lens, Left & Right, 62-67, Red, Each  
(Bulk P/N: 111 945 241D)
- 98-1076** T/L Lens, Left & Right, 68-70, Euro Style, Amber/Red/White, Each  
(Bulk P/N: 111 945 241JE)
- 98-1077** T/L Lens, Left & Right, 68-70, Red/White, Each  
(Bulk P/N: 111 945 241J)
- 98-9629** T/L Lens, Left, 71-72, Euro Style, Each  
(Bulk P/N: 113 945 241B)
- 98-9630** T/L Lens, Right, 71-72, Euro Style, Each  
(Bulk P/N: 113 945 242B)
- 98-2025** T/L Lens, Left, 71-72, Red/White, Each  
(Bulk P/N: 113 945 241A)
- 98-2026** T/L Lens, Right, 71-72, Red/White, Each  
(Bulk P/N: 113 945 242A)
- 98-1065** T/L Lens, Left, 73-79, Euro Style, Amber/Red/White, Each  
(Bulk P/N: 133 945 223A)
- 98-1066** T/L Lens, Right, 73-79, Euro Style, Amber/Red/White, Each  
(Bulk P/N: 133 945 224A)
- 98-1095-B** T/L Lens, Left, Type 1, 73-79, Economy Version
- 98-1096-B** T/L Lens, Right, Type 1, 73-79, Economy Version
- 98-9506** T/L Side Reflector, Left, Type 1, 70-72, Each  
(Bulk P/N: 113 945 109)
- 98-9507** T/L Side Reflector, Right, Type 1, 70-72, Each  
(Bulk P/N: 113 945 110)



### TYPE 2 LENSES

- 98-9501** Early H/L Lens, Type 2, thru 67, Glass, Each  
(Bulk P/N: 111 941 115H)
- 98-9504** Early H/L Lens, Vintage Euro Style, Type 2, 50-67, Glass, Each  
(Bulk P/N: 111 941 115HT2)
- 98-9508** Side Marker Lens, Type 2, 70-74, Yellow/Silver Trim, Each  
(Bulk P/N: 211 945 119A)
- 98-9509** Side Marker Lens, Type 2, 75-79, Yellow/Black Trim, Each  
(Bulk P/N: 211 945 119B)
- 98-9510** Side Marker Lens, Type 2, 70-74, Red/Silver Trim, Each  
(Bulk P/N: 211 945 363A)
- 98-9511** Side Marker Lens, Type 2, 75-79, Red/Black Trim, Each  
(Bulk P/N: 211 945 363B)
- 98-9512** Front Side Reflector Base, Type 2, 70-79, Each  
(Bulk P/N: 211 945 161)
- 98-9516** Bulb Holder, Rear Side Marker, Type 2, 70-79, Each  
(Bulk P/N: 211 945 351A)





# ELECTRICAL ACCESSORIES

## STOCK STYLE LENSES (Continued)

### TYPE 2 LENSES (Continued)

**98-9638** Turn Signal Lens, Left & Right, Type 2 56-62 / Type 1 55-57 Clear, Each

(Bulk P/N:111 953 161)



98-9638

**98-9640** Turn Signal Lens - Amber, Type 2 63-67, Left, Each  
(Bulk P/N:211 953 161B)



98-9640

**98-9641** Turn Signal Lens - Amber, Type 2 63-67, Right, Each  
(Bulk P/N:211 953 162B)



98-9641

**98-9525** Turn Signal Lens, Left & Right, Type 2, 68-72, Each  
(Bulk P/N: 211 953 141J)

**98-9635** Turn Signal Lens - Amber, Type 2 73-79, Left/Right, Each  
(Bulk P/N:211 953 141/142)



98-9635



98-9525

**98-9513** T/L Lens only, Type 2, 62-71, Red, Each  
(Bulk P/N: 211 945 241G)

**98-9454** T/L Lens, Left & Right, Type 2, 72-79, Amber/Red/White, Each  
(Bulk P/N: 211 945 241R)



98-9513



98-9454

### TYPE 3 & GHIA LENSES

**98-9626** Tail Light lens, Type 3 64-69, Each  
(Bulk P/N:311 945 223B)



98-9626

**98-9627** Tail Light lens, Type 3 70-73, Ghia 72-74, Each  
(Bulk P/N:311 945 223P)



98-9627

**98-9526** Turn Signal Lens, Bullet, Ghia 59-64 / Type 3 62-63, 68-69 Amber, Each  
(Bulk P/N: 315 953 161D)



98-9526

**98-9527** Turn Signal Lens, Bullet, Ghia 59-64 / Type 3 62-63, 68-69 Clear, Each  
(Bulk P/N: 315 953 161DCL)



98-9527

**98-9637** Turn Signal Lens, Left & Right, Type 3 70-73, Amber, Each  
(Bulk P/N:311 953 157J)



98-9637



98-9622

## BACK-UP LIGHTS - TYPE 1

Designed to replace the Bug, Ghia & Type 3 Back-Up lights with correct brackets for Right & Left. Great chrome finish and attention to detail. Can be used as a universal back-up light for many applications. Not suitable for driving lights.

**98-9622** Back-Up Light Assy., w/ Left Bracket & Boot, Type 1 64-67, Ghia 69-71, Type 3 67-69, Each

(Bulk P/N:181 941 071B)

**98-9623** Back-Up Light Assy., w/ Right Bracket & Boot, Type 1 64-67, Ghia 69-71, Type 3 67-69, Each

(Bulk P/N:181 941 072B)

**98-9625** Back-Up Light Lens Only, Type 1 64-67, Ghia 69-71, Type 3 67-69, 57-71 Type 2, Each

(Bulk P/N:111 941 371)



98-9623



98-9625



98-9624

## BACK-UP LIGHTS - TYPE 2

Designed to replace the 57-71 Type 2 Back-Up lights. Great finish and attention to detail. Can be used as a universal back-up light for many applications. Not suitable for driving lights.

**98-9624** Back-Up Light Assy., 57-71 Type 2, Each

(Bulk P/N:211 941 073)

**98-9625** Back-Up Light Lens Only, Type 1 64-67, Ghia 69-71, Type 3 67-69, 57-71 Type 2, Each

(Bulk P/N:111 941 371)



98-9625



6704

## TAIL LIGHT SEALS

High quality tail light seals. Fits Type 1 VWs.

**6704** Tail Light Seals, 62-67, Pair

(Bulk P/N: 111 945 191E, Pair)

**6705** Tail Light Seals, 68-70, Pair

(Bulk P/N: 111 945 191G/2A, Pair)

**6706** Tail Light Seals, 71-72, Pair

(Bulk P/N: 113 945 191/192, Pair)



6706



6705



## TAIL LIGHT SEALS - TYPE 2

Designed to replace the 62-71 Type 2 Tail light seals.

**98-9631** Tail Light Seals, Type 2 62-71, Each

(Bulk P/N:211 945 245A)



6701

## FRONT TURN SIGNAL SEALS

High quality seals include water drain tube on early models just like the original 1958-1969 models. Fits Type 1 VWs.

**6701** Turn Signal Seals, With Wiring Tube Attached, 58-63, Pair

(Bulk P/N: 111 953 193, Pair)

**6702** Turn Signal Seals, With Wiring Tube Included, 64-69, Pair (4 pcs.)

(Bulk P/N: 111 953 193E, Pair, 4 pcs.)

**6703** Turn Signal Seals, 70-79, Pair

(Bulk P/N: 113 953 193, Pair)



6702



6703



# ELECTRICAL ACCESSORIES

## VOLTAGE DROP

Allows 6-Volt wiper motors to operate with a 12-Volt power supply. Drops 12-Volt to approximately 8-Volt.

9384 Voltage Drop, Each

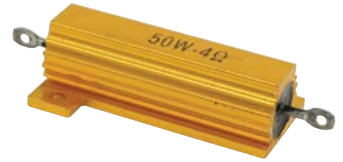

## WIPER CONVERSION KIT

Converts 6-Volt wiper motor for use with 12-Volt system and adds a Variable Speed feature to your wipers.

9344 Wiper Conversion Kit, Each

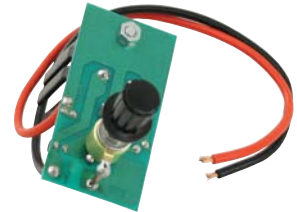

## 12 VOLT WIPER MOTOR

2 SPEED MOTOR  
NEGATIVE GROUND

17-2807 12 Volt Wiper Motor, Type 1, 72-77, 72 S/B, Boxed  
Can only be used with column switch  
(Ref P/N: 113 955 113G)



NEW  
NOT REBUILT

## WEATHER-PROOF G.M. STYLE FUSE BOX

Weather-Proof 10-position Fuse Box features G.M. Style Fuse receptacles, Spade Connectors. A sealed body and a clear top that also seals to the body with an O Ring. G.M. Style fuses are available in a number of amp sizes, easy to see if they are blown and are available practically everywhere. Update your Buggy or kit car with a modern fuse box.

9470 Weather-Proof G.M. Style Fuse Box



Style of Fuse

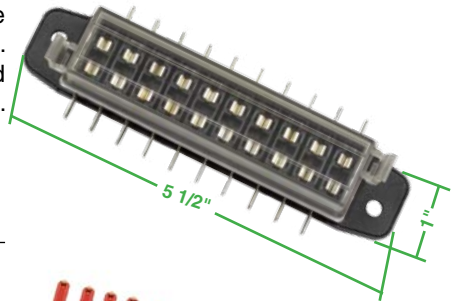

## FUSE PACKS

Replace worn or burned fuses and keep spares in the glove box! 20 Fuses per kit. For stock VW or P/N 16-9466 Fuse Box.

- 9905 Fuse Kit, 10 x 8-Amp, 10 x 16-Amp
- 9926 Fuse Kit, 10 x 8-Amp, 5 x 16-Amp, 5 x 25-Amp
- 9927 Fuse Kit, 20 x 8-Amp
- 9929-B 8 Amp (N171211), White, Box of 100
- 9930-B 16 Amp (N171214), Red, Box of 100
- 9931-B 25 Amp (N171215), Blue, Box of 100



## UNIVERSAL WIRE HARNESS W/FUSE BOX

Complete wiring kit includes 6 Panel fuse box, fuses, wire, ends, fittings, electrical tape and instructions. Great for Buggies, Kit Cars and other special applications.

9466 Universal Wire Harness w/Fuse Box  
16-9466 6 Panel Fuse Box Only



16-9466

9466

## MINI & MICRO MINI CHROME LIGHTS

These single and dual filament lights are ideal for clearance, parking, turn signal or tail lights. They feature diecast construction, and the prism lenses diffuse the light beam. Available with red and amber lenses. Comes with 12-Volt Bulbs.

### MINI LIGHTS, 2 5/16" X 1 3/4" X 2" (DUAL FILAMENT)



- 9334 Mini Light w/Red Lens, Each
- 9335 Mini Light w/Amber Lens, Each
- 9327 Replacement Dual Filament 12-Volt Bulb, 2 pcs.

### MINI LED TAIL LIGHT, 2 5/16" X 1 3/4" X 2"

Has a clear lens. Shows red stoplight and tail light, but goes amber in turn signal mode.



16-9836

- 16-9836 Mini LED Tail Light Red/Red/Amber, Each

### MICRO MINI LIGHTS, 1 3/4" X 1" X 1 1/2" (SINGLE FILAMENT)



- 9330 Micro Mini Light w/Red Lens, Each
- 9331 Micro Mini Light w/Amber Lens, Each
- 9326 Replacement Single Filament 12-Volt Bulb, 2 pcs.

## MINI / MICRO MINI BUMPER MOUNT LIGHT BRACKETS

These trick little brackets give you the option of mounting either the mini or the micro mini lights to any Beetle up to '73. Lights can be mounted above or below the bumper. The bracket attaches to the stock bumper bracket using the existing bracket bolt. Brackets are steel with a durable black finish and are sold as a pair.



9325

- 9325 Mini/Micro Light Mount Bracket, Type 1 thru 73, Pair

## HEADLIGHT SWITCHES AND RELAYS

- 98-9421-B Headlight Switch, Type 1 58-67, Ghia 58-67, Type 2 68-70, Type 3 64-67

(Ref. P/N: 311 941 531A)

- 98-9980-B Headlight Switch, Type 2 71-79

(Ref. P/N: 211 941 531E)

- 98-9437-B Relay, headlight (12-Volt), Type 1 67-79, Ghia 67-74, Type 2 67-79, Type 3 67-73, Each

(Ref. P/N: 111 941 583)



98-9980-B



98-9421-B



98-9437-B

## BRAKE LIGHT SWITCHES

Brake light switches deteriorate with age causing them to malfunction. If your brake lights don't come on with a small amount of pressure applied to the brake pedal, it's time to replace your switch.

- 98-2057 Brake Light Switch, 3 Prong

(Bulk P/N: 113 945 515G)

- 98-2058 Brake Light Switch, 2 Prong

(Bulk P/N: 113 945 515H)

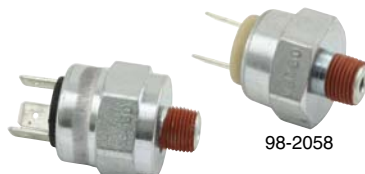

98-2058

98-2057



# ELECTRICAL ACCESSORIES

## IGNITION SWITCHES

Stock-Style or Universal switches for all applications.

- 98-2050** Ignition Switch w/Keys, Type 1, 58-67  
(Bulk P/N: 111 905 803D)
- 98-2053** Ignition Switch (Electrical Only), Type 1, 68-70  
(Bulk P/N: 311 905 865A)
- 98-9023-B** Ignition Lock Cylinder, w/Keys, Type 1 68-70, Ghia 68-70,  
Type 3 68-70, Each  
(Ref. P/N: 113 905 853)
- 98-2051** NEW! Ignition Switch w/Keys, Type 2, 55-67  
(Bulk P/N: 211 905 811C)
- 9306** Universal Ignition Switch w/Keys for 6 or 12-Volt Systems



## IGNITION SWITCH (ELECTRICAL)

This switch is the electrical part of the switch located behind the ignition lock cylinder. Fits Type 1 72-74.

- 98-9052** NEW! Ignition Switch, Type 1 72-74  
(Bulk P/N: 111 905 865K)



## HARD-START RELAY KIT - 12 VOLT

Allows increased juice to the starter by momentarily by-passing the ignition switch. Easy installation.

- 17-2917** Hard-Start Relay Kit

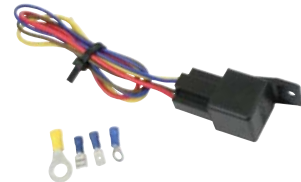

## REPLACEMENT TURN SIGNAL SWITCHES

- 98-9576** Turn Signal Switch, Type 1, 62-67, Ghia, 62-67, Black  
(Bulk P/N: 141 953 517F) Do Not connect dimmer switch wire on early cars  
OEM Type 1 62-65 is ivory in color. EMPI's is black.
- 98-9539** Turn Signal Switch, Type 1, 68-70  
(Bulk P/N: 311 953 513B)
- 98-9537** Turn Signal Switch, Type 1, 71  
(Bulk P/N: 111 953 513C)
- 98-9538** Turn Signal Switch, Type 1, 72-79  
(Bulk P/N: 111 953 513F)



## UNIVERSAL CHROME TURN SIGNAL SWITCH

EMPI's Universal Turn Signal Switch has a chrome plated metal housing & arm and includes an emergency flasher switch. Mounts on flat or rounded surfaces and comes with color coded wiring schematic. Six wire construction allows for use on either 1 or 2 tail light bulb configurations. Works on both 6 & 12-Volt systems.

**NOTE: L.E.D. lights need additional electronic flashers and wiring.**

- 16-2101** Universal Turn Signal Switch

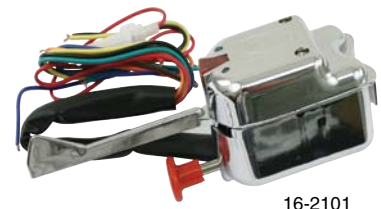



## HORNS

Stock replacement horns.

**98-2030** 6-Volt Horn, Each  
(Bulk P/N: 111 951 111H)

**98-2031** 12-Volt Horn, Each  
(Bulk P/N: 111 951 113B)



## PUSH BUTTON STARTER SWITCH

Great for off-road use. Also, can be installed as a remote switch for use when adjusting timing. 12 Volt.

**9367** Momentary Push Button Starter Switch, Sealed



## SEALED TOGGLE SWITCHES

Heavy duty switches with rubberized coating or our NEW injected-molded hard rubber body - all feature toggle lever boots and provide weather resistance for extreme use. Great for Baja's, Buggies, etc. 20 Amp.

**9360** Sealed Toggle Switch, Molded, On/Off

**9361** Sealed Toggle Switch, Off/On/On

**9362** Sealed Toggle Switch, Molded, Off/On/Momentary-On

**9363** Sealed Toggle Switch, On/Off/On (2-Pole)



## INDICATOR/WARNING LIGHTS

Universal indicator lights can be used for all accessories. Available in standard with 3/8" lens or larger "Super" size with 9/16" lens and chrome bezel. "Super" bezels have a .900" O.D. and standard bezels have a .640" O.D. Standard size installs into 1/2" holes, "Super" size require a 3/4" hole. 12 Volt, 2 Watt.

**9371** Std. Size Indicator Light, Green

**9372** Std. Size Indicator Light, Red

**9373** Std. Size Indicator Light, Blue

**9374** Std. Size Indicator Light, Amber

**9375** Super Indicator Light, Green

**9376** Super Indicator Light, Red

**9377** Super Indicator Light, Blue

**9378** Super Indicator Light, Amber



## BATTERY ISOLATOR SWITCH & SEAL KIT

Safety and security. Features removable key. The seal kit is a two piece kit that includes one seal for the key shaft and one with a weather tight cap for the switch base. For 6 or 12-Volt systems.

**9355** Battery Isolator Switch w/ seal, Set



# ELECTRICAL ACCESSORIES

## VDO GAUGES

The gauge that started it all. Great styling with uncompromising VDO quality. The choice of VW enthusiasts. Features flat black face, white numerals and red pointers. Uses electric senders unless otherwise noted. Speedometers are electronic and require an inductive sender to operate. Gauges are 2 1/16" diameter unless otherwise noted.



## VDO COCKPIT SERIES GAUGES

Cockpit series gauges with black face, white numerals and a red pointer.

- V150030\* Oil Pressure Gauge, Mech., 0-100 PSI
- V350040 Oil Pressure Gauge, 0-80 PSI
- V350041 Oil Pressure Gauge, 0-150 PSI
- V310012 Oil Temp Gauge, 300 Degree
- V310039 Water Temp Gauge, 250 Degree
- V150921\* Turbo Boost Gauge, Mech., 0-20 PSI
- V150052\* Boost Gauge, 0-30 PSI
- V310953 Pyrometer Kit, 1600 Degree
- V190903 Ammeter Gauge, 30 AMP
- V332041 Voltmeter Gauge, 8-16 Volts
- V301015 Fuel Gauge, 10-180 OHMs, Requires Sending Unit P/N: V226001
- V301020 Fuel Gauge, 73-10 OHMs, Requires VW Sending Unit or P/N: V221012
- V331953 Hour Meter Gauge
- V333051 Cockpit Tach, 7,000 RPM, 3 1/8"
- V333055 Cockpit Tach, 7,000 RPM, 3 3/8"
- V333959 Cockpit Tach, 8,000 RPM, 2 1/16"
- V437158 **NEW!** Vision (Flat Edge) Speedometer 140Mph/220Km, 3 15/16"
- V437050 Speedometer, 120 MPH, MPH only, 3 1/8" (Use P/N V340020 Inductive Sender or P/N:16-9290 Cable/Transducer Kit, See Page 362 and 363)
- V437052 Speedometer, 120 MPH, MPH only, 3 3/8" (Use P/N V340020 Inductive Sender or P/N: 16-9290 Cable/Transducer Kit, See Page 362 and 363)
- V437053 Speedometer, 160 MPH, MPH only, 3 3/8"  
\*Use installation Kit V150851 (6') or V150855 (16') on page 363



V350040



V190903



V310039



V301020



V333959



**NEW!**

V437158



V333055



V437052

VDO is changing their gauges from 12 Volt to 12/24 Volt. A change in the illumination circuit was required. 12/24 Volt gauges will feature the same Ground, Illumination Wire (Blue/Red Strip) and a New RED Switched Power Wire that must be connected via your ignition switch to illuminate the gage. This change affects all resistive pressure, temperature, fuel and water level gauges. Voltmeter gauges are not affected.

## VDO Performance Instruments



V350240



V437202



V333708

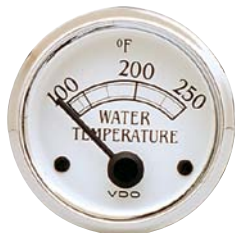

V310710



V301733



V332702



V310709

### VDO COCKPIT WHITE SERIES GAUGES

Cockpit series gauges with white face, black numerals and a red pointer.

**V350240** Oil Pressure Gauge, 0-80 PSI  
**V310239** Water Temp. Gauge, 0-250 Degree

**V150206** Turbo Boost, 25 PSI / 30 InHg  
**V332241** Voltmeter Gauge, 8-16 Volts  
**V301216** Fuel Gauge, 10-180 OHMs  
 (Use Sending Unit P/N: V226001)

**V333251** Cockpit Tach, 7000 RPM, 3 1/8"  
**V333255** Cockpit Tach, 7,000 RPM, 3 3/8"

**V437201** Speedometer, 120MPH, MPH only, 3 1/8"  
**V437202** Speedometer, 120 MPH, MPH only, 3 3/8"  
 (Use P/N V340020 Inductive Sender or  
 P/N 16-9290 Cable/Transducer Kit)



V310239



V150206

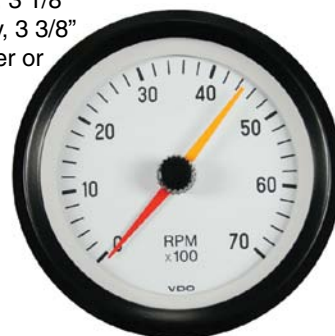

V333255

### VDO COCKPIT ROYALE SERIES GAUGES

Cockpit series gauges with white face, black classic numerals and a black pointer.

**V301733** Fuel Gauge (Must Use P/N V226001 Sender)  
**V310709** Oil Temp Gauge, 300 degree  
**V310710** Water Temp Gauge, 250 Degree  
**V332702** Voltmeter Gauge, 8-16 Volts  
**V350702** Oil Pressure Gauge, 80 PSI

**V333707** Tach, 7,000 RPM, 3 1/8"  
**V333708** Tach, 7,000 RPM, 3 3/8"

**V437750** Speedometer, 120 MPH, MPH only, 3 1/8"

VDO is changing their gauges from 12 Volt to 12/24 Volt. A change in the illumination circuit was required. 12/24 Volt gauges will feature the same Ground, Illumination Wire (Blue/Red Strip) and a New RED Switched Power Wire that must be connected via your ignition switch to illuminate the gage. This change affects all resistive pressure, temperature, fuel and water level gauges. Voltmeter gauges are not affected.





# ELECTRICAL ACCESSORIES

## VDO MINI SERIES

Compact gauges for monitoring pressure for oil or fuel.

**V153002** Mini PSI Gauge, 1 1/2" w/1/8" -27 NPT connections.

**V153003** Mini PSI Gauge, 1 1/2" w/1/8" -27 NPT connections.

## VDO CLOCK

**V370155** Black Analog Clock, 12V, 2 1/16" (52mm) Dia.

### NOTE:

VDO changed their gauge illumination to Press-In/Peanut-Style bulbs when they changed to their World Gauge Platform. Older VDO gauges feature old school brass pin-type bulbs.

New Press-In type bulb and sockets as noted in the catalog:

- V600815 Bulb
- V600813 Socket

**THESE ARE THE EXCEPTIONS** - which still have old school bulbs/sockets:

- V310901 - Cylinder Head Temp
- V310902 - Cylinder Head Temp
- V310953 - Pyrometer
- V333959 - Tach
- V333990 - Tach



V153003



V153002



V370155  
VDO Clock

VDO is changing their gauges from 12 Volt to 12/24 Volt. A change in the illumination circuit was required. 12/24 Volt gauges will feature the same Ground, Illumination Wire (Blue/Red Strip) and a New RED Switched Power Wire that must be connected via your ignition switch to illuminate the gage. This change affects all resistive pressure, temperature, fuel and water level gauges. Voltmeter gauges are not affected.

## EMPI GAUGE MOUNTING ACCESSORIES

Secure mounting guarantees performance for all gauges and tachometers while adding a clean look for all applications.

**14-1014** Metal Mount Brkt, Chrome, 2 1/16", 1 Hole

**14-1009** Metal Mount Brkt, Black, 2 1/16", 1 Hole

**14-1012** **NEW!** Metal Mount Brkt, Chrome, 2 1/16", 2 Hole

**14-1010** Metal Mount Brkt, Black, 2 1/16", 2 Hole

**14-1013** Metal Mount Brkt, Chrome, 2 1/16", 3 Hole

**14-1011** Metal Mount Brkt, Black, 2 1/16", 3 Hole



14-1009 / 14-1014



14-1010 / 14-1012



14-1011 / 14-1013

14-1003

14-1007

## EMPI GAUGE READY DASH PANELS

Dash panels are made to accept gauges and tachs. Choose black or chrome. For all 2 1/16" gauges and 3 1/8" tachs.

**14-1005** 1 Gauge Hole Panel, Black

**14-1006** 1 Gauge Hole Panel, Chrome

**14-1003** 2 Gauge/1 Tach Hole Panel, Black

**14-1004** 2 Gauge/1 Tach Hole Panel, Chrome

**14-1007** 2 Gauge Hole Panel, Black

**14-1008** 2 Gauge Hole Panel, Chrome

**14-1001** 3 Gauge Hole Panel, Black

**14-1002** 3 Gauge Hole Panel, Chrome

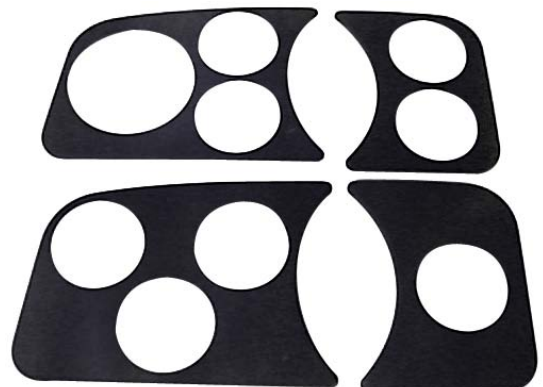

14-1001

14-1005

## VDO GAUGE MOUNTING ACCESSORIES

Secure mounting guarantees performance for all gauges and tachometers while adding a clean look for all applications.



**V240101** Mount Cup, 2 1/16" w/Long Housing

**V600401** Stud Mount Conversion Kit, 3 1/8"  
**V600402** Stud Mount Conversion Kit, 2 1/16"

**V240864** Gauge Hole Cover, 2 1/16"

**V240005** Anti-Glare Ring, 2 1/16", Pack of 2



## VDO BULBS & SOCKETS

- V600802** Bulb, 9/32" 12V/2W, 4 pcs.
- V600816** Socket for V600802, Steel, Each
- V600804** Bulb, 11/32" 12V/2W, 4 pcs.
- V600819** Socket for V600804, Each
- V600809** Bulb, Peanut Style, 4 pcs.
- V600815** Bulb, Large Peanut Style, 4 pcs.
- V600813** Insulated Bulb Socket, 3/8", Each
- V600840** Insulated Bulb Socket, Peanut Style, Each

## VDO LIGHT DIFFUSERS

The easy and convenient way to change the lighting color in your VDO gauge. Simply slips over the light bulb to give your dash a whole new color at night.



- V600853** Light Diffuser – Red, 9/32, (4 pcs)
- V600856** Light Diffuser – Green, 9/32", (4 pcs)
- V600857** Light Diffuser – Red, 11/32", (4 pcs)
- V600859** Light Diffuser – Red, Peanut, (4 pcs)
- V600860** Light Diffuser – Green, Peanut, (4 pcs)

## ELECTRIC SPEEDO TO CABLE CONVERSION KIT

This kit allows you to hook up an electronic speedometer into a Type 1 sedan without modifying your drums or rotors. The custom designed cable utilizes the O.E.M. dust cap hole with an inductive sensor on the opposite end, which can be easily wired to your electronic speedometer.



**16-9290** Electric Speedo to Cable Conversion Kit

## DUST BOOT

**98-9809-B** Dust Boot, Speedometer Cable, Type 1 61-77, Ghia 56-74, Each  
(Ref. P/N: 111 957 861)





# ELECTRICAL ACCESSORIES

## BRASS "T" FITTING / ADAPTER

9205 Brass T Fitting/Adapter (1/8"), For Gauges, Each



9205

## VDO WIRING KITS & ADAPTERS

All the necessary hardware to complete your gauge installations.

V240023 Wiring Kit, All Electric Gauges  
V240026 Push-On Connector Kit, 3 Prong  
V240021 Wiring Kit for Ammeter



V240021



V240023



V240026

## VDO SENDERS & ADAPTERS

V323055 Temp Sender 300 Degree, M14-1.5 (VW Drain Plug)  
 V323056 Temp Sender 300 Degree, M16-1.5  
 V323064 Temp Sender 300 Degree, M18-1.5 (Oil Press. Relief)  
 V323423 Temp Sender 300 Degree, M10-1.0

V323057 Temp Sender 300 Degree, 1/8" - 27 NPT  
 V323058 Temp Sender 300 Degree, 1/4" - 18 NPT

V323088 Temp Sender 250 Degree, M10-1.0  
 V323095 Temp Sender 250 Degree, 1/8" - 27 NPT

V323701 Temp Sender, 14mm, for V310901, Head Wire 16' Long (Head Temp., Under Spark Plug)

V360001 Oil Press Sender 80 PSI, M10-1.0, 1 Pole  
 V360006 Oil Press Sender 80 PSI, M10-1.0, 2 Pole  
 V360003 Oil Press Sender 80 PSI, 1/8" - 27 NPT, 1 Pole  
 V360009 Oil Press Sender 80 PSI, 1/8" - 27 NPT, 2 Pole

V360015 Oil Press Sender 150 PSI, M10-1.0, 1 Pole  
 V360023 Oil Press Sender 150 PSI, M10-1.0, 2 Pole  
 V360025 Oil Press Sender 150 PSI, 1/8" - 27 NPT, 2 Pole

V150851 Tubing Kit, 6' Long  
 V150855 Tubing Kit, 16' Long

V240850 Replaced by EMPI P/N 9205

V221012 Fuel Tank Sender, VW  
 (See page 135 for P/N 98-2021-0 non-VDO Brand)

V226001 Fuel Tank Sender, Universal (5-Bolt Pattern) (10 OHMs Empty, 180 OHMs Full)

V226451 Mount Kit for V226001

V340020 Inductive Sender for VDO Speedometers Only  
 Requires purchase of self-adhesive magnets. Can be applied to c.v. joint for sender to read as they rotate past the magnet. (Magnets available thru Radio Shack, McMaster Carr, Granger, etc).



V323088



V323055



V360001



V323701



V360006



V226001



EMPI 9205



V221012



V226451



V340020



## AUTO METER GAUGES

The Racer's Favorite – NASCAR, NHRA, FORMULA DRIFT – Racers choose Auto Meter...and with good reason. Accuracy, Durability, Visibility and Styling. Require electrical sending units unless otherwise noted. **All Autometer Gauges Include Sending Units, Except Fuel Level Gauges.**  
 Note: Last four digits of part number are Auto Meter.

### SPORT COMP SERIES

- 14-3708 Sport Comp Tach, 8,000 RPM, Mini Comp, 2 5/8"
- 14-3780 Sport Comp Tach, 8,000 RPM, Standard, 3 3/4"
- 14-3900 Sport Comp Tach, 10,000 RPM Monster Tach, 5"
- 14-3905 Sport Comp Tach, 8,000 RPM w/Shift-Lite, 5"
- 14-3980 Sport Comp Tach, 8,000 RPM Monster Tach, 5"
- 14-3991 Sport Comp Tach, 8,000 RPM Dash Mount, 3 3/8"
- 14-3987 Sport Comp Speedometer, 120MPH Dash Mount, 3 3/8"



14-3905



14-3780

### ULTRA-LITE SERIES

- 14-3910 Ultra-Lite Tach, 10,000 RPM, 5"



14-3987



14-3910

### CARBON FIBER SERIES

- 14-4703 Carbon Fiber Vacuum/Boost, 2 1/16"
- 14-4716 Carbon Fiber Fuel Level, 2 1/16"
- 14-4727 Carbon Fiber Oil Pressure 2 1/16"
- 14-4737 Carbon Fiber Water Temp, 2 1/16"
- 14-4803 Carbon Fiber Vacuum/Boost, 2 5/8"
- 14-4816 Carbon Fiber Fuel Level, 2 5/8"
- 14-4827 Carbon Fiber Oil Pressure 2 5/8"
- 14-4837 Carbon Fiber Water Temp, 2 5/8"
- 14-4848 Carbon Fiber Oil Temp, 2 5/8"
- 14-4891 Carbon Fiber Voltmeter, 2 5/8"
- 14-4899 Carbon Fiber, 10,000 RPM w/Shift-Lite, 5"
- 14-4798 Carbon Fiber, 10,000 RPM Dash Mount, 3 3/8"
- 14-4789 Carbon Fiber Speedometer, 160MPH Dash Mount, 3 3/8"



14-4703



14-4899



14-4727

### PHANTOM SERIES

- 14-5703 Phantom Vacuum/Boost, 2 1/16"
- 14-5791 Phantom Voltmeter, 2 1/16"
- 14-5803 Phantom Vacuum/Boost, 2 5/8"
- 14-5816 Phantom Fuel Level, 2 5/8"
- 14-5847 Phantom Oil Temp, 2 5/8"
- 14-5780 Phantom, 8,000 RPM Pedestal Mount, 3 3/4"
- 14-5887 Phantom Speedometer, 120MPH Dash Mount, 3 3/8"



14-5887



14-5816



14-5847



14-5703



## SHOW BARS

Fully jig-welded for precision fit these show bars are available in 4 point, made from 2" O.D. tubing or 6 Point made from 1 1/2" O.D. tubing. Fits all Bugs except Convertible. (Not for competition use) **Shipped by Truck only.**

- 3116 Show Bars, 4 Point - Bolt-In or Weld-In, .1025" Wall Thickness, (Raw)
- 3119 Show Bars, 6 Point - Weld-In, .095" Wall Thickness, (Raw)



## OFFSET HOLE - COLORED SHOW BAR PADDING

Offset hole location allows padding to be positioned to provide more protection for driver/passengers. Manufactured in pre-cut 3 foot lengths with 1 1/2" I.D. (10 pieces per bulk box, priced per box). (Ordering 1 = 10 pcs.)

- 16-2096 Roll Bar Pad, Black, 10-Piece Box
- 16-2092 Roll Bar Pad, Blue, 10-Piece Box



## RUBBER HOOD HOLD-DOWNS

Strong black synthetic rubber latches are self-aligning, rattle free and feature plated steel hardware. A must for your Baja Bug.

- 3016 Rubber Hood Hold-Downs, Pair

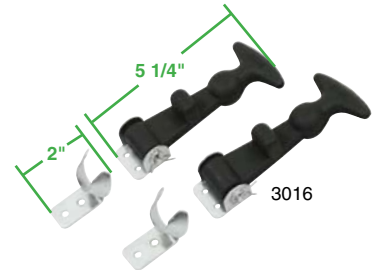

## CHROME HOOD HOLD DOWNS

Chrome Steel, spring-loaded hood hold downs for securing your 1-Piece front end. Also great for other body panels, tool boxes, trailer ramps and other applications.

- 3011 Chrome Hood Hold Downs



## BAJA HOOD PIN KITS

Chrome hold-down with "Pit Pins" holds any hood or deck lid.

- 3017 Hood Pin Kit w/Lanyards, Pair



## BAJA BUMPER HARDWARE

Replacement hardware fits all of our 1 1/2" tube bumpers. Weld on flanges for custom applications.

- 3841 Bumper Flange, 1 1/2" Tube, Pair
- 3841-7 Bulk Bumper Flange, 1 1/2" Tube, Each
- 3837 Hardware Only, Firewall Mount, 4 pcs.
- 3838 Hardware Only, Shock Mount, 4 pcs.
- 3840 Hardware Only, Front Bumpers, 2 pcs.

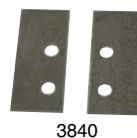

## DOUBLE TUBE BAJA BUMPERS

Feature the added protection and good looks of double 1 1/2" steel tubes. Fits all Type 1 Bugs, except S/B. Comes complete with hardware.

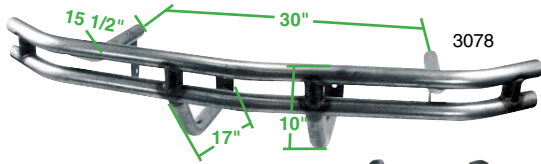

### FRONT BUMPER

3078 Double Tube Bumper, Front (Raw)



### REAR BUMPER

3079 Double Tube Bumper, Rear, Fire Wall Mount (Raw)  
**Shipped by Truck Only**

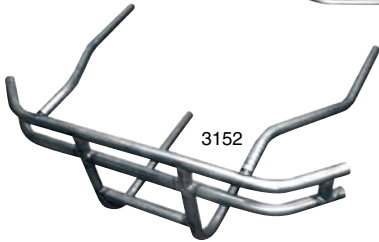

3152 Double Tube Bumper, Rear, Shock Tower Mount (Raw)  
**Shipped by Truck Only**

## BAJA BUMPERS

Protect your Baja's exposed nose and engine from damage with 1 1/2" steel tube bumpers. Fits all Type 1 Bugs except S/B. Comes complete with hardware.



3101 Baja Bumper, Front, Fits Wide & Bug Eye (Raw)

3105 Baja Bumper, Rear, Shock Tower Mount (Raw)  
**Shipped by Truck Only**

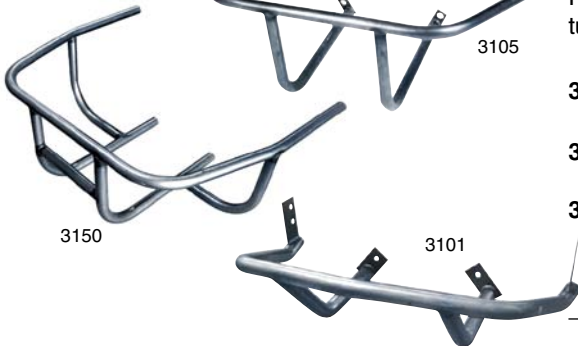

3150 H.D. Baja Bumper, Rear, Shock Tower Mount (Raw)  
**Shipped by Truck Only**

## BAJA SIDE BARS

Replaces running boards and offers side protection from rocks and brush. Available in low mount and high mount versions. The top mounting point of the high mount version is approximately half way up the quarter panel for added strength. Comes unpainted, ready to prime and paint. Fits all Type 1 Bugs.

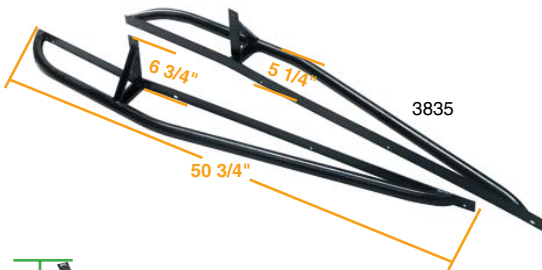

### LOW MOUNT

3835 Low Mount Baja Bars, 1 1/4" Tube, (Raw), Pair

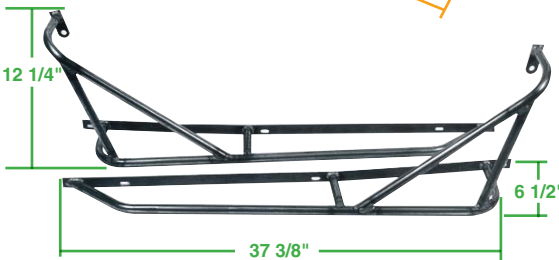

### HIGH MOUNT

3839 High Mount Baja Bars, 3/4" Tube, (Raw), Pair



## STAINLESS STEEL BAJA BUMPERS

Protect your Baja's exposed nose and engine from damage with 1 1/2" stainless steel tube bumpers. Fits all Type 1 Bugs except S/B. Comes complete with hardware. **Hardware is not Stainless Steel.**

- 3117** **NEW!** Stainless Steel Baja Bumpers, Front Fits Wide & Bug Eye
- 3118** **NEW!** Stainless Steel Baja Bumper, Rear, Shock Tower Mount **Shipped by Truck Only**



## CHROME TUBULAR BUMPERS

Designed for Baja Bugs and Dune Buggies to give excellent protection with an off-road look in a quality chrome finish. Separate kits, for front and rear installation, each kit includes hardware.

- 3108** **NEW!** Chrome Buggy King Pin Front Bumper
- 3109** **NEW!** Chrome Buggy Ball Joint Front Bumper
- B551700** **NEW!** Chrome Tubular Rear Bumper



## BUGPACK DUNE BUGGY WINDSHIELDS

Without question we manufacture the finest Dune Buggy windshields. Exclusive production methods enable us to build many styles and sizes without expensive costs. All frames are a polished and anodized aluminum extrusion to provide custom looks and strength. Windshields are made to fit the body precisely so be sure to include the necessary measurements when ordering. Frames can be ordered without AS-1 safety glass if local installation is available. Kits include all mounting rubber, glazing vinyl and bottom brace.

- B604510** **NEW!** Windshield W/16" Glass, 41 3/4-42" **Shipped by Truck Only.**
- B604511** **NEW!** Windshield W/16" Glass, 42 1/4-42 1/2" **Shipped by Truck Only.**
- B604512** **NEW!** Windshield W/16" Glass, 43 1/2-43 3/4" **Shipped by Truck Only.**
- B604711** **NEW!** Windshield Frame Only, 41 3/4-42 1/2" **Shipped by Truck Only.**
- B604712** **NEW!** Windshield Frame Only, 43 1/2-43 3/4" **Shipped by Truck Only.**

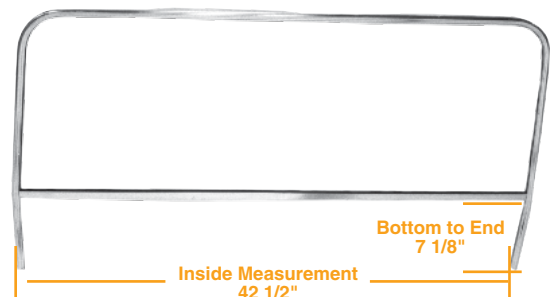

## REPLACEMENT PARTS FOR WINDSHIELD KITS

- 18-1057** **NEW!** Replacement Seal for Windshield, 10ft
- 18-1058** **NEW!** Replacement Bottom Seal for Windshield, 44 inch





## FUEL FILLER / GAS COVER

Flange with flush screw-in cover for access to internal fuel fillers. Made of high impact black plastic. Mounts on flat surfaces.

**16-6032** Flush Mount Access Flange & Cover



## PULLEY GUARDS

Protect your pulley and belt from the "Big Chunks". Also avoid injury due to accidental contact when engine is running. Choose from two styles made of heavy gauge steel and chrome plated. Includes mounting hardware.

**8665** Chrome Pulley Guard, Louvered  
**9136** Chrome Pulley Guard, Mesh



## CHROME PUSH ROD TUBE PROTECTORS

Chrome plated steel protectors look good and protect push rod tubes against engine damage from rocks and debris.

**8950** Chrome P/R Tube Protectors, Boxed, Pair

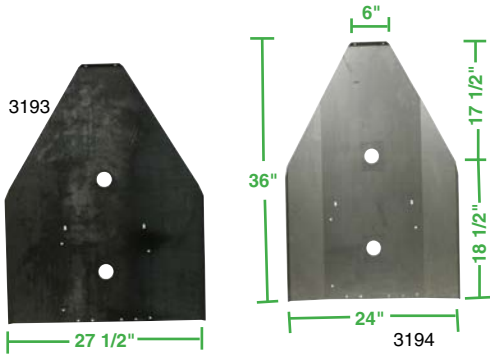

## OFF-ROAD SKID PLATES

Bug or Buggy - save your engine and trans from damage from the "Big Chunks". Made from heavy gauge steel and includes mounting hardware.

**3193** Universal Baja Bug Skid Plate  
 (Fits with Stock Heater Boxes) +  
**3194** Univ. Buggy Skid Plate  
 (Must Use Off-road Exhaust System) +



## UPPER & LOWER FRONT END SUPPORTS

Help eliminate bent front beams with these supports. Upper Supports bolt to beam and body while Lower Supports bolt from beam to pan. Made from heavy wall steel tubing. Fits all Type 1 except S/B. Pan modification is necessary.

**3842** Lower Front End Supports, Raw, Pair  
**3843** Upper Front End Supports, Raw, Pair



## UNIVERSAL TABS, MOUNTS & BRACKETS

Fabrication is a whole lot easier when you can just pick up a pre-made piece and weld it in place. EMPI now offers a large selection of items to help you out when you're setting up a new chassis or just re-working an old one. (All items are raw). The radius on all tabs is made to accommodate 1 1/2" tubing.

- 16-1121 Flat Mount Tab, 1/4" Hole, Set of 4
- 16-1122 Flat Mount Tab, 5/16" Hole, Set of 4
- 16-1123 Flat Mount Tab, 3/8" Hole, Set of 4
- 16-1126 1" Tube Tab, 1/4" Hole, Set of 4
- 16-1128 1 1/4" Tube Tab, 5/16" Hole, Set of 4
- 16-1131 1 1/2" Tube Tab, 5/16" Hole, Short, Set of 4
- 16-1132 1 1/2" Tube Tab, 5/16" Hole, Long, Set of 4
- 16-1133 1 1/2" Tube Shock Mount Tab, 7/16" Hole, Set of 4
- 16-1141 Oil Filter Adapter Mount, Each
- 16-1142 90 Degree Flat Gusset, Set of 4
- 16-1143 90 Degree Formed Gusset, Set of 4
- 16-1146 90 Degree Formed Mount Tab, 3/8" Hole, Set of 4
- 16-1148 Aluminum Gas Tank Mounts, Fits 8" or 10", Pair
- 16-1147 Pedal Mount Bracket, Fits EMPI, CNC, Each
- 3186 Universal Mounting Tab, 3/8" Hole, Set of 4
- 3186-7 Bulk Universal Mounting Tab, 3/8" Hole, Each
- 3189 Universal Mounting Tab, 1/2" Hole, Set of 4
- 3188 Bulk Universal Mounting Tab, 1/2" Hole, Each

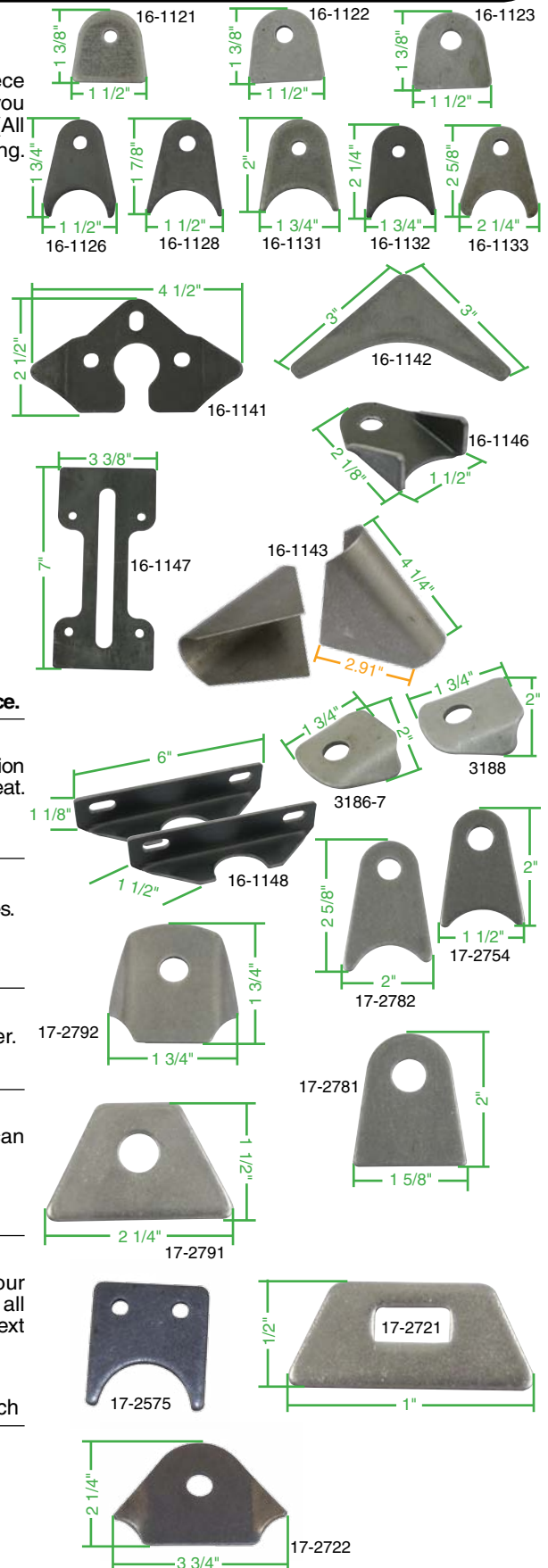

**Note: Most flanges are available in bulk. Ask your sales person for assistance.**

## CHROMOLY SEAT TAB

Radiused for 1 1/2" tubing. These chromoly tabs make mounting suspension seats easy. Available in tall and standard heights to elevate the front of the seat.

- 17-2754 Chromoly Tab, Seat Mount Standard, Pair
- 17-2782 Chromoly Tab, Seat Mount Tall, Pair

## FORMED CHASSIS TABS

These tabs are a fabricators most popular choice. Available with 3/8" or 1/2" holes.

- 17-2792 Chromoly Tab, 3/8", Set of 4
- 17-2793 Chromoly Tab, 1/2", Set of 4

## CHROMOLY SEAT BELT TAB

The chromoly material makes bolting that seat belt set that much stronger.

- 17-2781 Chromoly Tab, Seat Belt, Set of 4

## SEAT OR BELT MOUNTING TAB

A universal design used to mount mostly seats or seat belts. This tab can be used almost anywhere. Available in mild steel or chromoly. Set of 4.

- 17-2720 Tab, Seat Belt, Mild Steel, Set of 4
- 17-2791 Tab, Seat Belt, Chromoly, Set of 4

## UNIVERSAL TAB

That's right. Look at this little beauty. A tab that you can weld onto your chassis and zip tie your wires and lines to. No more black zip ties going all the way around the tubes. These take the detail of your vehicle to the next level. Set of 4.

- 17-2721 Universal Tab, Set of 4
- 17-2575 Universal Mounting Tab for Reservoirs, Raw, Each

## LARGE OFF ROAD LIGHT / WHIP TAB

Extra wide tab works well when mounting lights or whips.

- 17-2722 Tab, Large, Set of 4

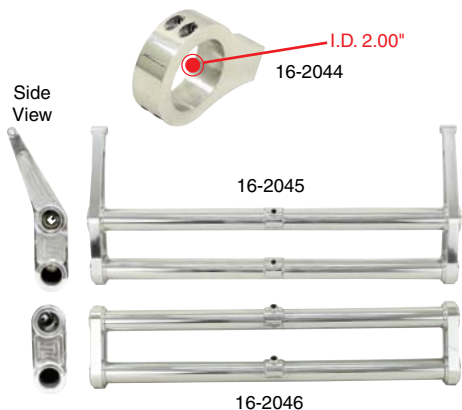

## EMPI ALUMINUM LINK PIN AXLE BEAM

Polished Aluminum Link Pin beam is lightweight and attractive for all Sand Buggy applications. Available with or without shock towers. (Not for Sedans or Heavier Buggies). To use a stock steering damper, use EMPI's new Billet Aluminum Steering Damper Mount. **Urethane bushings: For 16-2045 use 16-5139 and for 16-2046 use B658411. These bushings are listed on pages 194, 203 and 372.**

- 16-2045** EMPI Aluminum Link Pin Beam, w/Shock Towers
- 16-2046** EMPI Aluminum Link Pin Beam, w/o Shock Towers
- 16-2044** Aluminum Billet Steering Damper Mount



## FRONT END CLAMPS

Mount a VW front beam to a tube chassis with our Front End Clamps. Made from heavy duty stamped steel. Choose chrome plated for that custom look or raw for fabrication. Also use these to mount aluminum beam and baja tube bumpers.

- 3162** Chrome Axle Beam Clamp Kit, 4 pcs.
- 3162-7** Bulk Chrome Axle Beam Clamp, Each



- 3161** Raw Axle Beam Clamp Kit, 8 pcs., Includes Hardware
- 3161-7** Bulk Raw Axle Beam Clamp, Each



## BRAKE LINE TAB

For the chassis fabricator building that next project.

- 17-2716** Tab, Brake Lines, Pair

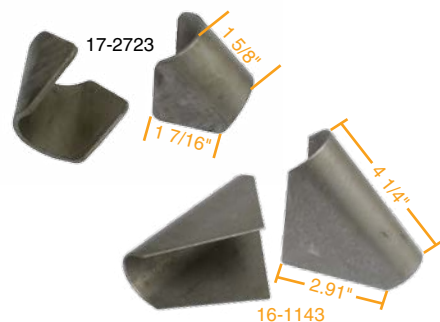

## 90 DEGREE CHASSIS GUSSET

Add extra strength to chassis corners, uprights and roll cages.

- 17-2723** Gusset, 90 Degree, .115" Thick, Set of 4
- 16-1143** Gusset, 90 Degree, .078" Thick, Set of 4



## SHOCK RESERVOIR BRACKET

This weld-on bracket replaces the old urethane and hose clamp method. Sold as pairs. For 2.0" Reservoirs.

- 17-2719** Bracket, Shock Reservoir, Pair



## STAINLESS STEEL LINE CLAMPS

These stainless steel clamps put the finishing touch on those clutch and brake line installations. Available for 3/16" or 1/4" line. Set of 4.

- 17-2717** Stainless Steel Clamp, 3/16" Line, Set of 4
- 17-2718** Stainless Steel Clamp, 1/4" Line, Set of 4



## QUICK RELEASE FASTENERS

These are the fasteners that are used to hold supersonic airplanes and bullet trains together. Designed for quick removal and replacement of panels and body parts. (Buttons are for 5/8" installed height).

- 16-8230 Self-Ejecting Button Only, 5/16" x .450" Grip, Each
- 16-8232 Self Ejecting Button Only, 20 pcs.
  
- 16-8231 Fastener Tab w/Spring, Each
- 16-8233 Fastener Tab w/Spring, 20 pcs.
- 17-2841 Fastener Tab, Flat w/5/16"-24 Nutplate, Each
- 17-2842 Fastener Tab, Formed w/5/16"-24 Nutplate, Each
- 17-2843 Fastener Tab, Formed w/3/8"-24 Nutplate, Each
- 17-2850 Fastener Tab, Formed, Lightened, Each
- 17-2851 Fastener Tab, Flat, Short, Each
- 17-2852 Fastener Tab, Flat Long, Each
  
- 17-2845 Button Stud, Short Non-Ejecting  
13/32" x .550" Grip, Each
- 17-2846 Button Stud, Long Non-Ejecting  
13/32" x .600" Grip, Each
- 17-2847 Wing-Nut, Non-Ejecting, Each
- 17-2849 Spring Only for Tabs (1"), Each
- 17-2853 Spring Only for Tabs (1.4"), Each

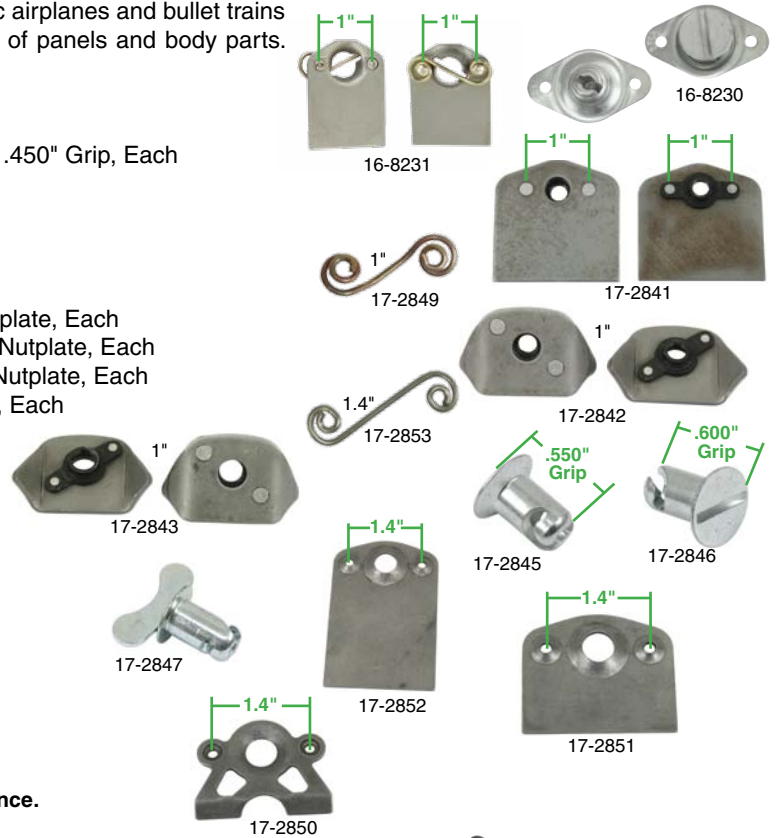

Note: Available in Bulk. Ask your Sales Person for Assistance.

## LONG TRAVEL SHOCK TOWER KIT

Use EMPI's pre-cut components to convert the stock VW Link Pin axle beam to an off road high-jumping long travel set up. Use with shocks with at least 10" shaft travel. Fabrication and welding required.

(P/N: 97-1014 KYB KG5530 shock is recommended for this application)

- 17-2646 Long Travel Shock Tower Kit (10") for Link Pin, Set, Raw



## BEAM MOUNTING BRACKETS

Steel mounting brackets for installing a beam front end to a chassis or frame head. Fits all aftermarket beams, or stock king-pin beam. **MUST BE WELDED**

- 17-2648 Beam Mounting Brackets, Pair



## BATTERY BOX

- 16-9503 Battery Box, 5 1/8" x 7 7/8", Weld onto Frame,  
Fits Smaller Batteries, Complete with Hardware



## URETHANE BUSHINGS, COUPLERS & STOPS

The strength and durability of Urethane will out-last and out-perform standard rubber products in every application. From Shift Couplers to Bump Stops, install Urethane and never look back! All urethane is red in color except where noted. [See page 203 for dimensions.](#)



- 16-5107** Urethane Control Arm Bushing Kit - S/B 71-73 (15-Piece Kit)
- 16-5108** Urethane Control Arm Bushing Kit - S/B 74-79 (15-Piece Kit)



- 16-5109** Urethane Snubber - Link Pin, Pair



- 16-5122** Urethane I.R.S. A-Arm Pivot Bushings, Pair



- 16-5123** Urethane Round Stacked Bump Stop, Pair



- 16-5125** Urethane Rear Snubber - All Bugs, Pair

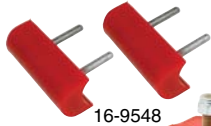

- 16-9547** Urethane Shaped Bump Stop 2" Long for 1 1/2" Tube, Pair



- 16-9548** Urethane Shaped Bump Stop 4" Long for 1 1/2" Tube, Pair



- 16-5126** Urethane Square Bump Stop 1 7/8" x 1 3/8", Pair



- 16-5136** Urethane Axle Beam Bushing Kit, **Outer**, for King & Link w/Micarta Bushings, 4 pcs.



- 16-5137** Urethane Axle Beam Bushing Kit, **Outer**, for King & Link Pin w/Bearings, 4 pcs.



- 16-5140** Urethane Axle Beam Bushing Kit, **Inner & Outer**, for King & Link Pin w/Bearings, 4 pcs.



- 16-5139** Urethane Axle Beam Bushing Kit, **Inner & Outer**, for King & Link Pin w/Micarta Bushings, 4 pcs.



- 16-5141** Urethane Axle Beam Bushing Kit, **Outer**, for Ball Joints, 4 pcs.



- 16-5142** Urethane Axle Beam Bushing Kit, **Inner & Outer**, for Ball Joint, 4 pcs.



- 16-5143** Urethane Axle Beam Bushing Kit, for Aluminum Beam w/45mm Tubes, 4 pcs.



- 16-5144** Urethane Axle Beam Bushing Kit, for Steel Beam 2.000" Tube/.120 Wall, 4 pcs.



- 16-5138** Urethane Axle Beam Tube Seals, Type 1 w/King & Link Pin, 4 pcs.



- 16-5145** Urethane Axle Beam Tube Seals, Type 1 w/Ball Joint, 4 pcs.



- 16-5146** Urethane Axle Beam Bushing Kit, for any of our Off-Road Axle Beams, 4 pcs.

16-5138

16-5145

16-5146



**CHROMOLY LINK PINS**

4140 Chromoly link pins for heavy duty forged trailing arms. Available in 45/64" (17.9mm) O.D. and 7/8" (22.2mm) O.D. Set of 4.

- 17-2799 Chromoly Link Pins 45/64" (17.9mm), Set of 4  
Smooth Area 82.6mm, Overall Length 116.70mm
- 17-2555 Chromoly Link Pins 7/8" (22.2mm), Set of 4  
Smooth Area 92.8mm, Overall Length 125.00mm



**LINK PIN SPINDLE GUSSET KIT**

Strengthen your stock Link Pin spindles with these gussets/supports. The 4 piece kit includes two gussets that weld to the spindle carriers and two that weld to the spindles to triangulate the tie rod arms. This helps these stock components withstand the extra stresses of off-road driving. Welding required.

- 3166 Link Pin Spindle Gusset Kit, 4 pcs., Raw



**LINK PINS FOR MULTI-SHOCK TRAILING ARMS**

These extended link pins are designed to accommodate front trailing arms set up for Multi-Shocks.

- 17-2554 Multi-Shock Link Pins, Pair



**LINK PIN SHIMS**

Link pin shims for 45/64" (17.9mm) and 7/8" (22.2mm) link pins.

- 17-2758 Shims, Link Pin 45/64" (17.9mm), Set of 5
- 17-2557 Shims, Link Pin 7/8" (22.2mm), Set of 5



**LINK PIN BUSHINGS**

Link pin bushings for 45/64" (17.9mm) and 7/8" (22.2mm) link pins. **(Press In)**

- 17-2757 Bushings, Link Pin 45/64" (17.9mm), Set of 4
- 17-2556 Bushings, Link Pin 7/8" (22.2mm), Set of 4



**4 PISTON CALIPER BRACKETS**

Install the popular 4 piston calipers on front and rear axles. Bolt patterns are 5 1/4" on center. 3/8"-24 threaded mounting holes. Can be used with EMPI P/N # 16-2525-7 Calipers.

- 17-2677 Caliper Bracket, Front, VW Ball Joint Spindles, Left / Right, Ea.
- 17-2678 Caliper Bracket, Rear, VW Swing Axle and IRS, Each

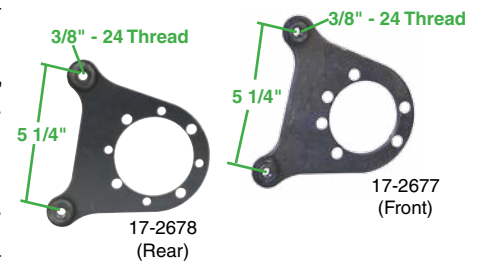

**LINK PIN DISC BRAKE BRACKET**

Allows you to put OE calipers on a link pin spindle. M10 x 1.5 thread.

- 17-2753 Bracket, Disc Brake Link Pin, Each



**2 PISTON CALIPER BRACKET**

This bracket allows you to use the VW OEM 2 piston caliper or EMPI P/N 98-1150-B Caliper. These must be fabricated to fit your desired application. M10 x 1.5 thread. **Must be welded on.**

- 17-2679 OEM Caliper Bracket, Pair



## EMPI FORGED H.D. KING PIN SPINDLE KIT

Complete Spindle, Knuckle and Pin set with beefed up Forged spindles. Gussets forged into the spindle and steering arm for added strength. Great for your Baja or Buggy. FORGED Gussets built into the spindle and steering arm. Use stock VW tie rods.

22-2976

FORGED H.D. King Pin Spindle Kit, Pair

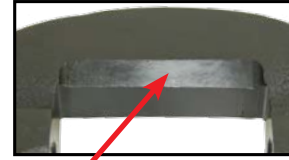

**NEW DESIGN**

Gussets on the knuckles have been machined for steering clearance.

### SPINDLE COMPONENTS



- 98-4051-B** Spindle Nut, Left  
(Ref. P/N: 111 405 671)
- 98-4052-B** Spindle Nut, Right  
(Ref. P/N: 111 405 672)
- 9616** Aluminum Linkpin Clamp Nut, Pair
- 17-2795** King Pin Conversion Bearing, Inner, Each  
O.D. = 1.977", I.D. = .9845"
- 17-2796** King Pin Conversion Bearing, Outer, Each  
O.D. = 1.570", I.D. = .7875"
- 98-1156-B** Axle Seal  
(Ref. P/N: 321 501 641)
- 17-2797** Combo Spindle Bearing, Inner, Each  
O.D. = 2.437", I.D. = 1.251" (Race Ref. #15244)
- 17-2798** Combo Spindle Bearing, Outer, Each  
O.D. = 2.052", I.D. = 1.0005"
- 98-5021-B** Axle Seal  
(Ref. P/N: 113 501 315H)

### HEAVY DUTY AXLE BEAM THRU RODS

A proven off road design that eliminates torsion leaf springs and replaces them with steel rods allowing you to use coil-over shocks. Must be used with P/N 17-2548 clamps.



- 17-2545** Thru Rod, Stock Width Beam, Pair, 40.5" Long, Boxed
- 17-2546** Thru Rod, 5" and 6" Wider Beam, Pair, 46.5" Long, Boxed
- 17-2547** Thru Rod, 8" Wider Beam, Pair, 48.75" Long, Boxed

### THRU ROD CLAMPS

Must be used when using P/N 17-2545, 17-2546, and 17-2547 beam thru rods. These clamps thread onto the ends of the rods and tighten with a set screw, securing the rods in place. Sold in sets of 4.



- 17-2548** Clamp, Thru Rod, Set of 4



## SHOCK BOSS / SHOCK BOLT

For fabricating shock mounts. Comes in 1/2" or 12mm x 1.5 bolt sizes. Threaded or unthreaded.

- 17-2712 Shock Boss, Unthreaded 1/2", 1 3/4" Long, Each
- 17-2713 Shock Boss, Unthreaded 12mm, 1 3/4" Long, Each
- 17-2714 Shock Boss, Threaded 12mm, 2" Long, Each
- 17-2715 Shock Boss, Threaded 1/2", 2" Long, Each
- 18-1040 **NEW!** Shock Bolt w/ Nut, 12mm x 1.5, 100mm Long, Each



## MISALIGNMENT SHIM FOR HEIM ENDS

Stainless steel adapter for Heim end alignment and offset. 3/4" OD x 5/8" ID x 1/2".

- 17-2645 S/S Misalignment Shim, Heim end, Each



## HEAVY DUTY TIE ROD ENDS

Ford Tie Rod Ends have Zerk Fitting on the back (pictured).

- 17-2591 Tie Rod End Ford, Left Hand 3/4" - 16 Thread Shank, Each
- 17-2592 Tie Rod End Ford, Right Hand 3/4" - 16 Thread Shank, Each



## POLISHED STAINLESS STEEL HEAVY DUTY TIE ROD ENDS

- 17-2595 S/S Tie Rod End I.H., Left Hand 3/4" - 16 Thread Shank, Each
- 17-2596 S/S Tie Rod End I.H., Right Hand 3/4" - 16 Thread Shank, Each



## CHROME STEERING ARMS

Chrome steering arms to connect tie rods to VW steering boxes.

- 17-2565 Steering Arm, Chrome, Large Shaft, Small Tie Rod End, 46-65, Each
- 17-2566 Steering Arm, Chrome, Small Shaft, Small Tie Rod End, 66-68, Each
- 17-2567 Steering Arm, Chrome, Small Shaft, Large Tie Rod End, 69-77, Each



## ALUMINUM LINK PIN CLAMP NUTS

Machined Aluminum nuts for all Link Pin front spindles.

- 9616 Aluminum Link Pin Clamp Nuts, Pair



**Race Trim**

## RACE-TRIM MICRO STUB BRAKE KITS

State of the art suspension is just one step away! Micro-stub brake systems are necessary if you are going to use a rear suspension that is different from a VW style trailing arm arrangement. This Race-Trim kit utilizes the best of the best in both components and materials used. 4-piston brake calipers, vented rotors, forged chromoly stub axles, forged hub assemblies, 6061 T-6 aluminum alloy rotor hats & wheel adapters. This combination gives you the winning edge, whether it's for racing or just an all out turbo long-travel sand car! Kits come complete ready for fab-in installation and are sold as a set. In addition we also offer a Micro-Arm flange tube to facilitate installation of the Race-Trim Micro Stub brake kit to a tubular trailing arm. Bolt pattern is 5 on 205.

(See pages 244-245 for additional details on this item).

- 16-2510 Race-Trim Micro Stub Brake Kit, for 930 C.V. Joints
- 16-2511 Race-Trim Micro Stub Brake Kit, for 934 C.V. Joints
- 16-2516 Mount Tube Only for Race-Trim Micro Stub Kit, Pair (Not Installed) (Not included in brake kits)
- 16-2525-7 Replacement Caliper, Each, w/o pads
- 16-2525-6 Replacement Pads, Two Pair
- 16-2510-2 Replacement Left Rotor Only, Each
- 16-2510-7 Replacement Right Rotor Only, Each
- 16-2510-1 Replacement Hub Bearing Assembly, Each
- 16-2510-4 Replacement Wheel Adapter, Each
- 16-2510-3 Replacement Aluminum Hub, Each
- 16-2510-5 Replacement Cap, Each
- 16-2510-8 Replacement Bracket, Each
- 16-2413 Repl. 3/8" x 24, 12 point, grade 8 (930), 6 pcs.
- 16-2414 Repl. 7/16" x 20, 12 point shouldered, grade 10.9 (934), 6 pcs.
- 16-2310 Microstub Axle w/ washer for 930 CV Joint, Each
- 16-2311 Microstub Axle w/ washer for 934 CV Joint, Each



**USE DOT3 FLUID ONLY**

## RACE-TRIM FRONT DISC BRAKE KITS OFF-ROAD & SAND CARS W/ COMBO SPINDLES

State of the art braking! This Race-Trim kit utilizes the best of the best in both components and materials used. Billet Wilwood calipers and pads, 5/205 Bolt Pattern. Supplied with 14mm Studs, Chrome Lug Nuts and Polished Aluminum Center Caps. Bearing races are pressed into hubs.

- 16-2517 Race-Trim Off-Road Front Disc Brake Kit, for Combo Spindles
- 16-2517-3 Replacement Rotor, Left / Right Only, Each
- 16-2517-6 Replacement Caliper, Each, w/o Pads
- 16-2517-7 Replacement Pads, Two Pair



## BILLET BRAKE LINE UNION

Billet brake union allows clean installation of all brake lines to one location. Tapped 1/8" NPT. Two other holes on top are for mounting.

- 17-2812 Billet Brake Line Union, Each

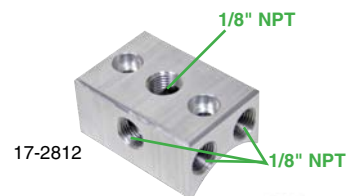

## UNIVERSAL BRAKE LINE UNION

Trick brake line union allows clean installation of brake lines. Tapped 1/8" NPT.

- 17-2919 Universal Brake Line Union, Each

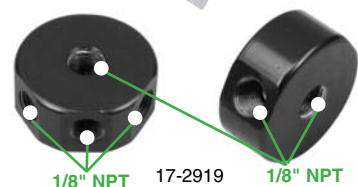





## POLISHED ALUMINUM BUGGY MASTER CYLINDER

Large 22mm bore, Polished Aluminum Master Cylinder for 2 or 4 wheel brake applications while adding a show-look to your buggy. Chose a Billet or Plastic reservoir.

- 16-7041 **NEW!** 22mm Polished Aluminum Buggy Master Cylinder, w/Residual Valve
- 16-7042 **NEW!** 22mm Polished Aluminum Buggy Master Cylinder, w/o Residual Valve



## BUGGY MASTER CYLINDER

The large 22mm bore Master Cylinder is large enough to handle 2 or 4 wheel set-ups. Available complete with reservoir or replacement reservoir only.

- 6112 22mm Buggy Master Cylinder, w/Residual Valve and Reservoir
- 98-6020-B Plastic Reservoir Only  
(Ref. P/N: 211 611 301C)
- 98-6021-B 22mm Buggy Master Cylinder Only w/Residual Valve  
(Ref. P/N: 211 611 011JCH)
- 98-6022-B 22mm Buggy Master Cylinder Only w/o Residual Valve.  
For use with Disc Brakes. (Does not include reservoir)



## BUGGY MASTER CYL. W/POLISHED ALUM. RESERVOIR

Every year it's the first thing on your shopping list...New brake reservoir to replace the sun baked or leaking one from last season. EMPI puts an end to the vicious cycle with this polished Billet Aluminum Reservoir, it's the best looking and last one you will need.



- 6114 22mm Buggy Master Cylinder w/Residual Valve and Polished Aluminum Reservoir
- 16-7040 Polished Billet Aluminum Master Cylinder Reservoir Only w/Cap
- 98-6021-B 22mm Buggy Master Cylinder Only w/Residual Valve  
(Ref. P/N: 211 611 011JCH)



## BUGGY MASTER CYLINDER WITH BILLET ALUMINUM RESERVOIR

Complete Type 2 Master Cylinder with the great looking Billet Aluminum Buggy Master Cylinder Reservoir to add that billet flare to your Buggy.

- 6116 **NEW!** Buggy Master Cylinder with Billet Aluminum Reservoir, Set



## BILLET ALUMINUM BUGGY MASTER CYLINDER RESERVOIR

Great looking Billet Aluminum Buggy Master Cylinder Reservoir to add that billet flare to your Buggy. Includes Billet Cap and gasket. Fits Type 2 (thru 66) master cylinders (EMPI P/N 16-7041, 16-7042 and 98-6021-B/211-611-011JCH).

- 18-1015 **NEW!** Aluminum Buggy Master Cylinder Reservoir, Each



## BRAKE LINE FITTING KIT

Includes 6 brass 1/8NPT (Male) to 3/16 American Inverted Brake Line (Female) for use when plumbing Pedal Assemblies, Turning Brakes, etc.

- 16-2550 Brake Line Fittings, Brass, Package of 6



## RACK & PINION UNITS

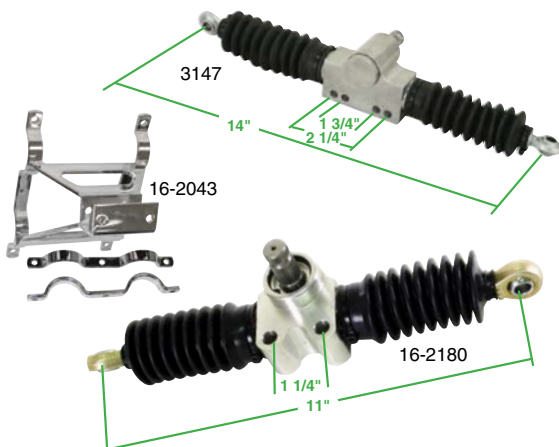

- 3147** Rack & Pinion Unit, 4 Mounting Holes, 14" 5/8 - 36 Spline Shaft, 1 1/2 Turns Lock to Lock, Each, (Boxed)
- 16-2043** Bolt-In Mount for P/N: 3147 Rack & Pinion

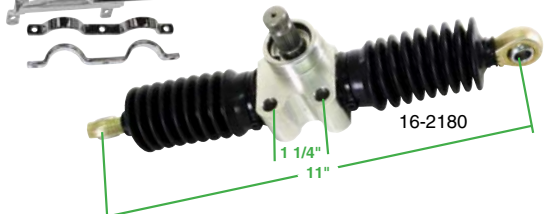

- 16-2180** Rack & Pinion Unit, 2 Mounting Holes, 11" 5/8 - 36 Spline Shaft, 1 1/2 Turns Lock to Lock, Each, (Boxed)

## RACK & PINION COMPONENTS



- 3142** Broached Coupler Only for all R & P Units (36 Spline)
- 3143** Splined Stub Adapter only for all R & P Units (36 Spline)
- 3149** U-Joint for Rack & Pinion, 5/8"-36 Splines on both ends (Black)
- 16-9572** U-Joint for Rack & Pinion, 5/8"-36 Splines on both ends (Chrome)
- 16-2187** Boot Clamp for P/N: 16-2183 and 17-2600, Each
- 16-2188** Clevis for P/N: 16-2183 and 17-2600, 5/8-18 R.H. Thread, Each
- 16-2191** Replacement Boot for P/N: 16-2185/86, Each
- 3144** Replacement Boot for P/N: 3147 / 16-2180/81/82, Each
- 16-2193** Bracket for P/N: 16-2181/82, Each
- 3145** Tie Rod Kit for P/N: 3147
- 3148** Chrome Tie Rod Set w/ Link Pin, Tie Rod End and Clevis, Ea. Fits 3147 and 16-2180 Rack & Pinion Units



## RACK AND PINION MOUNTING BRACKETS

This weld-on bracket allows you to install several different rack and pinion units to your vehicle. Available for stock beams and widened beams.



- 17-2604** Rack Mounting Bracket, Stock Beam, Each
- 17-2605** Rack Mounting Bracket, Wide Beam, Each

## CENTER LOAD RACK AND PINION UNITS

Designed for front steer spindles, these Rack & Pinion Units load from the front center of the rack. Distance between mounting holes is 6".

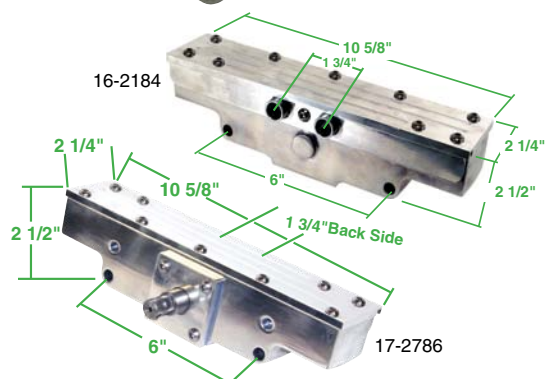

- 16-2184** Polished Center Load Rack, 5/8"- 36 Spline Shaft, Each (Boxed)
- 17-2786** Polished Billet Center Load Rack, 5/8"- 36 Spline Shaft, Each (Boxed)



## TIE ROD RELOCATION KIT

Eliminate added bump steer and unnecessary tie rod end wear on all lowered ball joint & Link pin front ends. Relocates tie rod end to underside of steering knuckle for improved angles. Requires drilling and the use of late model tie rod ends. Front-end alignment will be necessary for a complete installation.

**B661311** **NEW!** Tie Rod Relocation Bushing Kit, Pr.



## URETHANE TIE ROD BOOTS

Made from urethane, these boots are made to withstand the abuse of off-road racing. Superior design keeps dust and dirt from wearing out tie rod end prematurely and they look good.

**B557521** **NEW!** Urethane Tie Rod Boots, Stock VW, Red, 4 Pc.



## HEAVY DUTY ALUMINUM RACK AND PINION TIE RODS

Tie rods with I.H. ends for heavy duty rack and pinion boxes. 1" aluminum tube 24 1/4" long. Sold each.

**17-2598** Heavy Duty Aluminum Tie Rod, I.H. Ends, 3/4" Threaded Shank Zerk Fitting on Side, Each, (Bagged)



## CHROME TIE RODS

High luster chrome tie rods add the finishing touch to street cars, sand rails or buggies. Provided in see thru poly bags with header card for easy display.

- 22-2825** Chrome Tie Rod, Left, Early
- 22-2826** Chrome Tie Rod, Left, Late
- 22-2827** Chrome Tie Rod, Right, Early
- 22-2829** Chrome Tie Rod, Right, Early w/o Damper
- 22-2828** Chrome Tie Rod, Right, Late
- 22-2830** Chrome Tie Rod, Right, Late w/o Damper



## CHROME RACK & PINION TIE ROD KIT

For use with the Center Mount Rack and Pinion box. These Tie Rods have Link Pin Tie Rod Ends on one end and an adjustable Clevis end on the other, making for an easy installation. **No Welding Is Required.** Fits 3147 and 16-2180 Rack and Pinion Units.

**3148** Chrome Tie Rod Set w/ Link Pin, Tie Rod End and Clevis, Ea



## RACK AND PINION U-JOINTS

A complete line of steering U-Joints to accommodate the variety of rack and pinion units available.



17-2629

17-2622	3/4" Smooth, 3/4" Smooth, Each
17-2623	3/4" Smooth, 5/8" 36 Spline, Each
17-2624	3/4" Smooth, 3/4" 36 Spline, Each
17-2625	3/4" Smooth, 3/4" 48 Spline, Each
17-2626	7/8" Smooth, 7/8" Smooth, Each
17-2787	7/8" Smooth, 5/8" 36 Spline, Each
17-2627	7/8" Smooth, 3/4" 36 Spline, Each
17-2629	5/8" 36 Spline, 5/8" 36 Spline, Each
17-2630	3/4" 36 Spline, 3/4" 36 Spline, Each
17-2631	3/4" 48 Spline, 3/4" 48 Spline, Each
17-2633	3/4" 36 Spline, Charlynn Key Way, Each
17-2634	3/4" 48 Spline, Charlynn Key Way, Each

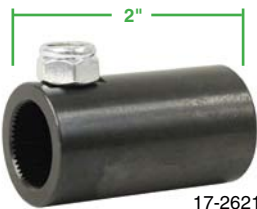

17-2621

## RACK AND PINION COUPLER

Splined 1/2 way through with locking set screw.

17-2620	Coupler, 3/4" 36 Spline, 2" Long, Each
17-2621	Coupler, 3/4" 48 Spline, 2" Long, Each



17-2617

## RACK AND PINION CLAMP STYLE COUPLER

Splined with outer clamp.

17-2616	Coupler, Clamp Style 5/8" 36 Spline, 1 3/4" Long, Each
17-2617	Coupler, Clamp Style, 7/8" Smooth w/ Charlynn Key Way, 2" Long, Each
17-2618	Coupler, Clamp Style, 3/4" 36 Spline, 1 3/4" Long, Each
17-2619	Coupler, Clamp Style, 3/4" 48 Spline, 1 3/4" Long, Each

## SPLINED STEERING SHAFTS

Splined shafts in various lengths and splines to fit most rack and pinion couplers. Splined on one end only.



17-2608

3143	Shaft, 2" Long, 5/8" 36 Spline, Each
17-2608	Shaft, 6" Long, 5/8" 36 Spline, Each
17-2609	Shaft, 12" Long, 5/8" 36 Spline, Each
17-2610	Shaft, 12" Long, 3/4" 36 Spline, Each
17-2611	Shaft, 12" Long, 3/4" 48 Spline, Each
17-2614	Shaft, 18" Long, 3/4" 36 Spline, Each (Boxed)
17-2615	Shaft, 18" Long, 3/4" 48 Spline, Each (Boxed)

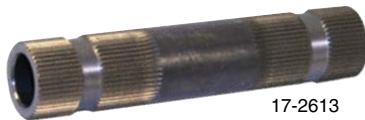

17-2613

## STEERING SHAFTS, SPLINED BOTH ENDS

17-2612	Shaft, 3 3/4" Long, 3/4" 36 Spline, Each
17-2613	Shaft, 3 3/4" Long, 3/4" 48 Spline, Each

## STEERING SHAFT MOUNT

This weld-on mount adds that extra detail to your sand rail or off road car. Available in 3/4" or 7/8" shaft size. This bracket welds on easily to your roll cage cross bar replacing the old tab and bearing look. A machined bronze bushing is inside to cut down on shaft wear. All have 5 1/8" O.A.L.

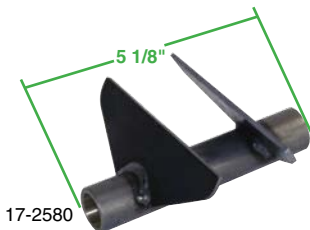

17-2580

17-2580	Mount, Steering Shaft, 3/4", Raw, Each
17-2582	Mount, Steering Shaft, 7/8", Raw, Each



## CHROME STEERING SHAFT & SUPPORTS

Steering shafts are available in 7/8" or 3/4" diameters and 60" long (cut to length). The 3 Bolt Flange fits all EMPI steering wheels. The steering shaft support fits 7/8" steering shaft and it's self-aligning for easy installation. Uses oil impregnated bronze bushing with oiling cup for long life.

- 3177 Chrome 7/8" Steering Shaft, Each Ups +
- 17-2579 Chromoly 3/4" Steering Shaft, Each Ups +
- 3180 Chrome Steering Shaft Bearing, 7/8", Each
- 17-2803 Chrome Steering Shaft Bearing, 3/4", Each
- 16-9568 3 Hole Steering Flange Only, Raw, Each

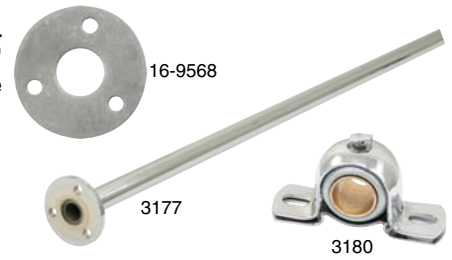

## STEERING WHEEL QUICK DISCONNECT

Allows steering wheel removal in seconds. Great for safety and easy access. Made from Aluminum with a steel insert. Requires Welding. **(Not for street use)**

- 3172 Steering Wheel Quick Disconnect 3/4" Tubing
- 16-9567 Steering Wheel Quick Disconnect 7/8" Tubing



## QUICK STEERING ADAPTER KIT

This bolt on adapter plate will reduce steering wheel travel almost one full turn, lock-to-lock. Designed for off-road use only, do not use this on a street driven car. All necessary hardware is supplied for attachment to your existing 1961 & later steering pitman arm. For Type 1 use only. **(Not for street use)**

- 22-2823 Quick Steer Kit - thru 5/68
- 22-2824 Quick Steer Kit - 5/68 & Later



## CHROME STEERING BOX AND SHAFT COUPLER

Chrome stock couplers for VW steering box and shaft. OE VW Splines.

- 17-2584 Stock Steering Coupler, Chrome, 2 pc. Set



## URETHANE STEERING COUPLER

- 16-5150 Urethane Steering Coupler Kit (Red)
- 16-5149 **NEW!** Urethane Steering Coupler Kit (Black)



## QUICK RELEASE STEERING COUPLER

Another design of quick release for off road steering wheels. With a pull ring design and splined shaft. Available for 3/4" and 7/8" steering shafts. There are two sets of mounting holes on this steering wheel quick release allowing you to use either a 5/16-18 bolt or a 1/4-20 bolt. **Fits 3-Bolt Flange Steering Wheels. (Not for street use)**

- 17-2800 Quick Release, Splined, 3/4", 2 pc. Set
- 17-2570 Quick Release, Splined, 7/8", 2 pc. Set



## COUPLING DISC TYPE 2

Coupling Disc Steering Shaft for Type 2

- 98-4169-B **NEW!** Coupling Disc, Steering Shaft, Type 2 68-79  
(Ref. P/N: 211 415 417)



## ALUMINUM CLAMP NUTS

These machined aluminum clamps are perfect for eliminating steering shaft movement and play. Available for both 3/4" and 7/8" shafts.

- 17-2585 Clamp Nut, 3/4" Shaft, Each
- 17-2586 Clamp Nut, 7/8" Shaft, Each



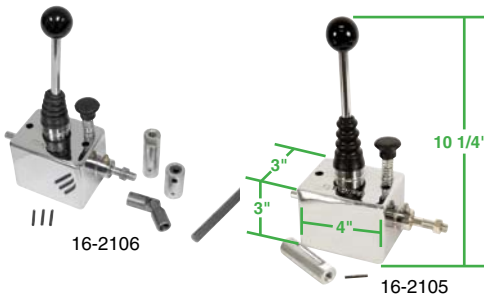

## EMPI CHROME SUPER SHIFTERS

Perfect for sand rails and custom buggies. EMPI's Super Shifters feature precise short shifting and reverse lock-out. Available with cut to length linkage for rear engine applications.

- 16-2105
- 16-2106
- 16-2161

- EMPI Universal Super Shifter Only, Chrome
- EMPI Universal Super Shifter w/Linkage, Chrome
- Replacement Boot Only for 16-2105 / 16-2106



## SHIFT ROD ADJUSTER

Shortened or fabricated shift rod? These weld on adjusters are what you need. Choose for early or late style coupler according to your application ([See shift couplers on this page](#))

- 16-2070
- 17-2724

- Shift Rod End, for Early Style Coupler, Each
- Shift Shaft Adjuster, for Late Style Coupler, Each



## URETHANE & STOCK SHIFT COUPLERS - EARLY STYLE

Urethane is the way to go for a shift coupler if you want to take sloppy play out of the equation. This early style coupler works for all Type 1 thru 64 along with other applications like off-road cars that use this style of shift linkage coupler. Supplied with new set-screws as well. Stock shift couplers also available.

- 16-5102 Urethane Shift Coupler, Early Style
- 98-1079 Early Shift Coupler  
(Bulk P/N: 111 711 175B)
- 98-1026-2 Grub Screw for Coupler, Each  
(Ref. P/N: 211 711 189A)



## POWER STEERING RESERVOIR WITH FILTER

Prolong the life of your power steering units with this reservoir-tank with spin-on filter. Available in 2 different mounting styles. The fittings are -8AN return and -10AN pump side.

- 17-2576 Reservoir with Filter, with Bracket, Each
- 17-2577 Reservoir with Filter, with Clamp on, Each



## POWER STEERING RESERVOIR TANK

Aluminum reservoir tank for power steering units. The fittings are -8AN and -10AN.

- 17-2572 Reservoir, Power Steering with Clamp on, Each

## CHARLYNN SHAFT KEY

For Charlynn torque generator key way.

- 17-2561 Charlynn Shaft Key, Each



## URETHANE SHIFT COUPLER - LATE STYLE

Much like the original one it replaces, this fits Type 1 65 on and other applications that use this style of coupler. The key improvement on this unit is the two inserts for the cage have been made out of urethane so the shifter linkage will be much tighter and responsive. This is a must do upgrade for almost every car out there that uses this style of shift coupler.

**16-5103** Shift Coupler, w/Urethane Inserts, Type 1 65-79, Ghia 65-74, Type 2 68-79, Type 3 All, Kit  
(Ref. P/N: 311 798 211)

**Heavy Duty Steel Cage with heavy duty bolt and Urethane Inserts make this H.D. Coupler the one to use for any performance application.**

**16-5105** H.D. Shift Coupler w/Urethane Inserts & Hardware., Type 1 65-79, Ghia 65-74, Type 3 All, Kit

**16-5104** **NEW!** Urethane Inserts Only for 16-5103 and 16-5105 Shift Couplers, Pr



## URETHANE SHIFT BUSHING

Will mount to EMPI's Universal Shifter Box, P/N 3158

**16-5101** Urethane Shift Bushing, Each



## RACE SHIFTER BOX WITH SHAFT

Steel box with bearing supported shaft. Cup is tapered and slotted for positive engagement with the shifter. Shaft is 1/2" O.D. and 10" long.

**17-2726** Off Road Shifter Mount Box, Each



## UNIVERSAL SHIFTER BOX

Accommodates VW shifters. Requires welding. This unit has 8mm x 1.25 Threads.

**3158** Universal Shift Box, Black, Each  
**3158-7** Bulk Universal Shift Box, Black, Each

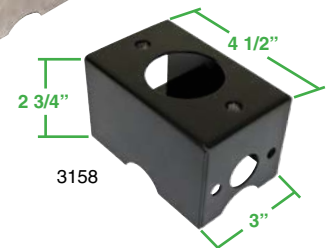

## UNIVERSAL TYPE I SHIFT SHAFT

This universal shaft has the original style slotted cup on the shifter end and are blank on the other end. Raw steel. Length from end to end is 59 3/8".

**17-2727** Universal Shift Shaft, 59" overall length, Each

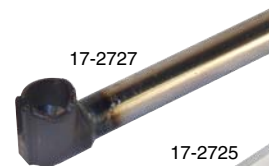

## TYPE I TO TYPE II COUPLER

Aligns Type I shift shaft to type II transmission coupler, aluminum.

**17-2725** Type I to Type II Shift Shaft Coupler, Each



## TRANSMISSION CENTER SUPPORT

Secures transmission from the bottom of the front case bolts. Supports from frame horns to reduce flex, zinc plated. Urethane stops included.

**17-2536** Bolt On Center Transmission Support



## BUS TRANSMISSION MOUNT

Weld in front mount brackets for late model bus transmission. Rear bolt mounts and hardware included.

**17-2537** Bus Transmission Mount Kit

**17-2538** Bus Transmission Center Mount Only



**NEW DESIGN**

**Polished Aluminum Body, Rebuildable**

## EMPI Billet Clutch Slave

Compatible with all hydraulic pedal assemblies. Note: proper straight angle mounting is critical to meet warranty requirements along with life of the unit. Brackets and heim ends are available for easier mounting and smoother operation. Housing is tapped 1/8 NPT in two spots. Female end of fitting supplied is 3/8-24. The other 1/8 NPT has a bleeder fitting in it.



- 16-2549 Clutch Slave Unit
- 16-2549-6 Rebuild Kit Only for 16-2549-0

## EMPI CLUTCH SLAVE ACCESSORIES

It is imperative that the slave be mounted in a level position... Brackets and heim ends make it easier to mount with smoother action.



- 17-2814 Slave Bracket, Type 1, Each
- 17-2883 Billet Slave Bracket, Type 1, Each
- 17-2813 Billet Slave Bracket, Type 2, Each
- 17-2884 Billet Slave Bracket, Mendeola, Each
- 17-2817 Heim End 3/8"-24 Threads, 3/8" Ball, for EMPI Slave, Each
- 17-2818 Heim End 3/8"-24 Threads, 5/16" Ball, for CNC Slave, Each



**USE DOT3 FLUID ONLY**

## RACE TRIM REBUILD KITS FOR PEDAL ASSEMBLIES AND TURNING BRAKES (P. 320)

- 16-2544 Rebuild Kit for 3/4" Clutch - 7/8" Brake Master Cylinder P/N 16-2530, 16-2531, and 16-2533
- 16-2545 Rebuild Kit for 7/8" Clutch - 7/8" Brake Master Cylinder P/N 16-2532
- 16-2546 Rebuild Kit for 3/4" Single Master Cylinder P/N 16-2534
- 16-2547 Rebuild Kit for 3/4" Angled Turning Brake Assembly P/N 16-2541 and 16-2543
- 16-2548 Rebuild Kit for 3/4" Upright Turning Brake Assembly P/N 16-2540 and 16-2542



## RACE TRIM MASTER CYLINDER - HIGH RESERVOIR

High Square Master Cylinder Reservoir can be used as a replacement for the EMPI Pedal Assemblies or in many other applications. Featuring a 3" high-capacity bowl they are 100% Polished with a Billet-style Knurled Cap. Available in 3/4" and 7/8" Bore sizes. Fitting size is 1/8" NPT.

- 17-2965 Master Cyl., 3/4" High Square Reservoir, Polished
- 17-2966 Master Cyl., 7/8" High Square Reservoir, Polished



## UNIVERSAL BLEEDER VALVE

Get the air out with this Universal Bleeder Valve. It can be used with Master Cylinders, Turning Brakes or other applications with 1/8" NPT threads.

- 17-2934 Bleeder Valve 1/8" NPT, Pair





## COMPLETE LINE OF RACE TRIM HYDRAULIC PEDAL ASSEMBLIES

Fully Polished and ready to bolt-in. Bore sizes included in the descriptions. A Shaft Pin to stop the shaft from rotating within the Pedal Base is included, along with instructions on how to drill shaft and install. EMPI Billet Clutch Slave needs to be ordered separately.

### RACE TRIM DUAL PEDAL ASSEMBLY

Dual Pedal Assembly Fully Polished w/Aluminum mounting bracket and high square reservoirs with easy fill cap.

- 16-2530** Dual Pedal Assembly, 3/4" Clutch - 7/8" Brake, fitting size is 1/8" NPT.
- 16-2531** Dual Pedal Assembly w/Throttle Pedal, 3/4" Clutch - 7/8" Brake, fitting size is 1/8" NPT.

### RACE TRIM SINGLE PEDAL ASSEMBLY

Single Pedal Assembly w/Dual Master Cylinders with built-in balance bar, or Single Master Cylinder. Fully Polished w/Aluminum mounting bracket and high square reservoirs with easy fill cap.

- 16-2532** Single Pedal Assembly w/Dual Master Cylinders 7/8" Brake - 7/8" Brake, fitting size is 1/8" NPT.
- 16-2533** Single Pedal Assembly w/Dual Master Cylinders 7/8" Brake - 3/4" Brake, fitting size is 1/8" NPT.
- 16-2534** Single Pedal Assembly w/Single Master Cylinder. 3/4" Brake/Clutch, fitting size is 1/8" NPT.

## RACE TRIM TURNING BRAKES

All of our turning brakes are Fully Polished with Chrome levers and Black popular ball grips. Available in Dual and Single Handle models, Upright or Angled. All feature 3/4" bore. The flow through system design does not interfere with your normal brake pedal. Available in Dual and Single Handles. The fitting size used on these is 1/8" NPT.

### RACE TRIM SINGLE HANDLE TURNING BRAKES

- 16-2540** Turning Brake, Single Handle, Upright, 3/4"
- 16-2541** Turning Brake, Single Handle, Angled, 3/4"

### RACE TRIM DUAL HANDLE TURNING BRAKES

- 16-2542** Turning Brake, Dual Handle, Upright, 3/4"
- 16-2543** Turning Brake, Dual Handle, Angled, 3/4"

## BRAKE LINE FITTING KIT

Includes 6 brass 1/8NPT (Male) to 3/16 American Inverted Brake Line (Female) for use when plumbing Pedal Assemblies, Turning Brakes, etc.

- 16-2550** Brake Line Fittings, Brass, Package of 6



## HYDRAULIC PEDAL ASSEMBLIES

Bore sizes included in the descriptions. EMPI Billet Clutch Slave needs to be ordered separately, P/N: 16-2549 sold separately.



16-2136



16-2137

### HEAVY DUTY 4 WHEEL SINGLE PEDAL ASSEMBLY

Single steel brake pedal with balance bar built in. Easy fill reservoir caps. Bore size indicates both master cylinders on the unit. Fitting size is 1/8" NPT.

- 16-2136** H.D. 4 Wheel Brake, Single Pedal, 3/4", w/High Square Reservoirs, Unpolished
- 16-2137** H.D. 4 Wheel Brake, Single Pedal, 3/4", w/Low Square Reservoirs, Unpolished
- 16-2176** H.D. 4 Wheel Brake, Single Pedal, 3/4", w/High Square Reservoirs, Polished
- 16-2177** H.D. 4 Wheel Brake, Single Pedal, 3/4", w/Low Square Reservoirs, Polished
- 16-2138** H.D. 4 Wheel Brake, Single Pedal, 7/8", w/Low Square Reservoirs, Unpolished
- 16-2196** H.D. 4 Wheel Brake, Single Pedal, 7/8", w/High Square Reservoirs, Unpolished
- 16-2178** H.D. 4 Wheel Brake, Single Pedal, 7/8", w/Low Square Reservoirs, Polished
- 16-2197** H.D. 4 Wheel Brake, Single Pedal, 7/8", w/High Square Reservoirs, Polished



16-2535

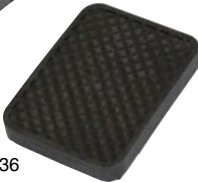

16-2536



16-2160



16-2167

## REPLACEMENT PARTS FOR HYDRAULIC PEDAL ASSEMBLIES & TURNING BRAKES

### PEDAL PAD

- 16-2535** Small Pedal Pad only for Dual Pedals on this page, Ea
- 16-2536** Large Pedal Pad only for Single Pedals on this page, Ea
- 16-2160** Small Pedal Pad only for Dual Pedals on this page, Ea
- 16-2167** Large Pedal Pad only for Single Pedals on this page, Ea



16-2161



16-2162

### BOOT

- 16-2161** Small Boot only for Round Master Cylinders on this page, Ea
- 16-2162** Large Boot only for Square Master Cylinders on this page, Ea

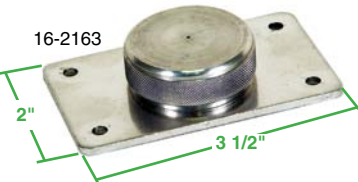

16-2163

### SQUARE TOP

- 16-2163** Square Top Only w/Screw on Cap for units on this page



16-2166

16-2165

### PEDAL PIVOT BOLT

- 16-2165** Pedal Pivot Bolt for units on this page
- 16-2166** Pedal Pivot Bolt for Roller Pedal for units on this page



## BILLET DELUXE PEDAL SLIDE

Constructed from billet aluminum this pedal slide fits most brand name hydraulic pedal assemblies. The base for the throttle pedal is incorporated into the unit, making for a very smooth and simple pedal adjustment. Use with P/N 17-2750 throttle cable extender. Hardware included.

- 17-2752 Deluxe Pedal Slide, Billet, w/ Throttle Pedal Provision, Each
- 17-2751 Pedal Slide, Billet, w/o Throttle Pedal Provision, Each

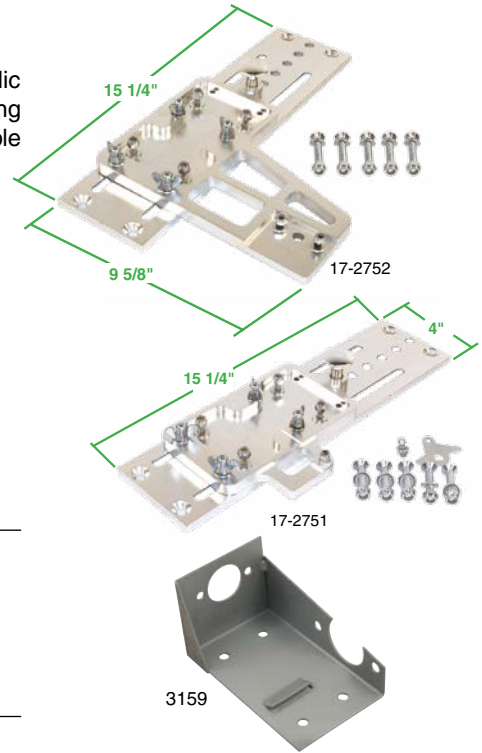

## PEDAL ASSEMBLY MOUNT

Easily mounts your VW brake and clutch pedal assembly. Requires welding.

- 3159 Pedal Assembly Mount, Raw, Each
- 3159-7 Bulk Pedal Assembly Mount, Raw, Each

## EMPI SHIELDED CONTROL / THROTTLE CABLES

Heavy Duty universal EMPI Cables for all your throttle cable needs. Requires mounting hardware. All cables have 10-32 threaded ends.

- 16-2076 Control Cable - 6'
- 16-2077 Control Cable - 7'
- 16-2078 Control Cable - 8'
- 16-2079 Control Cable - 9'
- 16-2080 Control Cable - 10'
- 16-2081 Control Cable - 11'
- 16-2082 Control Cable - 12'
- 16-2084 Cable Ball End (10-32 Thread)
- 16-2083 Cable Clevis (10-32 Thread)
- 16-2085 Hook Clamp Cable Mount
- 16-2086 Clamp and Shim Cable Mount
- 16-2087 Throttle Cable Extender, 8" Cut to Length, for Morse and EMPI Cables (10-32 Thread)

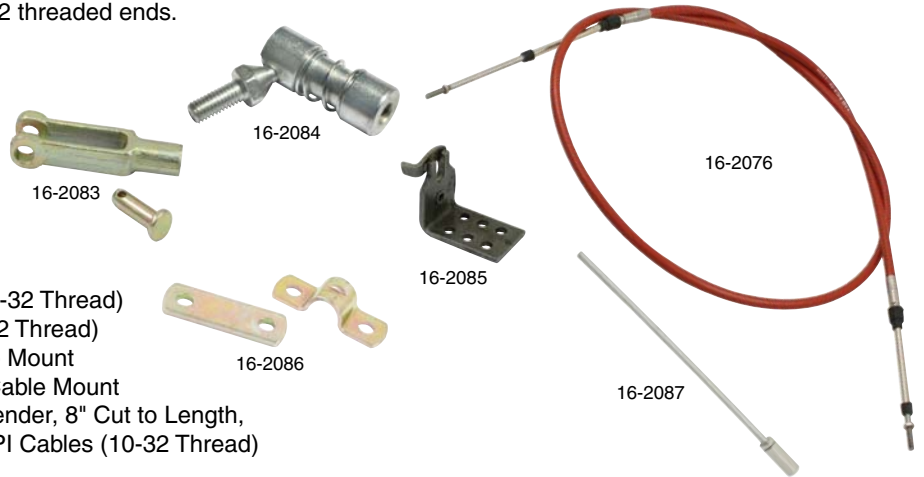

## THROTTLE CABLE EXTENDER

This makes adjusting the throttle cable quick and easy when using our pedal slide assemblies. Unit has a maximum of 19 1/2" of extension.

- 17-2750 Cable Extender, Adjustable, Each

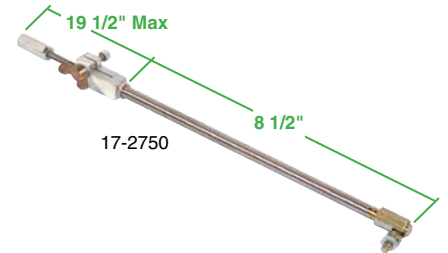

## ROLLER PEDAL CABLE BRACKET

Referred to as the "wish-bone", this stainless steel bracket is for use with all of our hydraulic pedal assemblies and provides for a direct attachment of the throttle cable without compromising bends.

- 16-9553 S/S Roller Pedal Cable Bracket





## FOOT PEDAL KIT (ALUMINUM)

Designed to be used with roller pedal to give smooth foot action on the throttle assembly. Lightweight cast aluminum construction. Fits sedans or buggies. Compliments our roller pedal P/N 3160.

**B556900** **NEW!** Aluminum Foot Pedal Only



## BILLET THROTTLE PEDAL

Billet Aluminum, spring-loaded throttle pedal. Positive action and great looks. Pedal features full-throttle stop and multi-position 10-32 threads for cable hook-up.

**16-3121** EMPI Billet Throttle Pedal w/Ball Milled Grooves & EMPI Logo

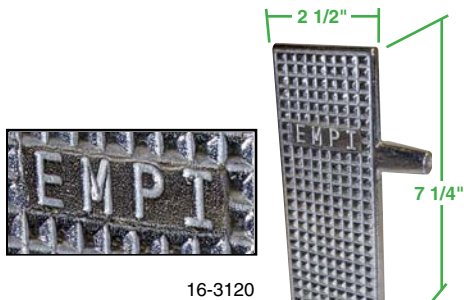

## EMPI UNIVERSAL THROTTLE PEDAL (ALUMINUM)

EMPI's heavy duty cast aluminum throttle pedal features a cast in grip pattern face and a ball burnished finish for a long lasting shine. Cable attachment has a 10-32 thread.

**16-3120** Universal Throttle Pedal

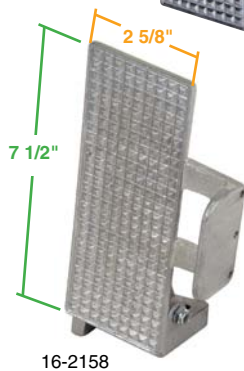

## ALUMINUM THROTTLE PEDALS W/ FOOT BRACE

**16-2158** Angled Throttle Pedal, Unpolished



## CABLE SHORTENING KITS

Shorten your clutch, emergency brake and throttle cables quickly and easily. A must for buggies with shortened pans.

- 3167** Complete Cable Shortening Kit, Includes P/N: 3168, 3169 & 3170
- 3168** Cable Shortening Kit, Clutch Only
- 3169** Cable Shortening Kit, Emergency Brake Only
- 3170** Cable Shortening Kit, Throttle Only (Fits on cable only)
- 3171** Throttle Cable Extending Kit, 2 pcs. (Fits on cable end or cable)
- 3171-7** Round PC only for Throttle Cable Extending Kit, Each



## H.D. THROTTLE CABLE KIT

H.D. throttle cable puts an end to cable failure. Includes plastic tubing for Buggies or Sedans with rusted throttle tubes. Cable kit includes 9-foot heavy duty cable, tubing and clamps.

- 4860** H.D. Throttle Cable Kit
- 4861** H.D. Throttle Cable Kit, w/Roller Pedal
- 4860-7** H.D. Throttle Cable Only, 9' Long (Skin Packed)
- 4860-6** **NEW!** Bulk H.D. Throttle Cable Only, 9' Long
- 4862-7** H.D. Throttle Cable Only, 16' Long (Skin Packed)
- 4862-6** **NEW!** Bulk H.D. Throttle Cable Only, 16' Long

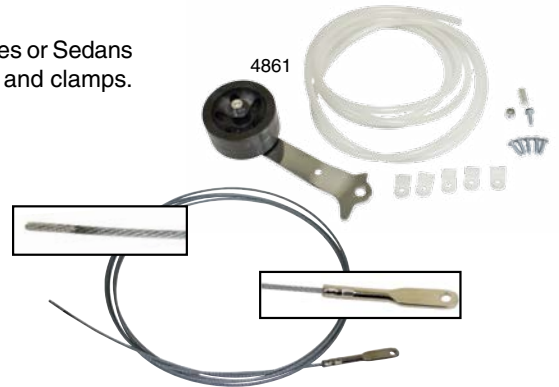

## RACING THROTTLE CABLE

Super heavy duty stainless steel 1/8" throttle cable is virtually indestructible. Comes in a sufficient length to satisfy all custom installations.

- B551010** **NEW!** Racing Throttle Cable 11'



## THROTTLE CABLE TUBE

Stock throttle tube passes through fan housing protecting cable from wear and breakage.

- 98-1002** Stock Throttle Cable Tube  
(Bulk P/N: 043 129 893)

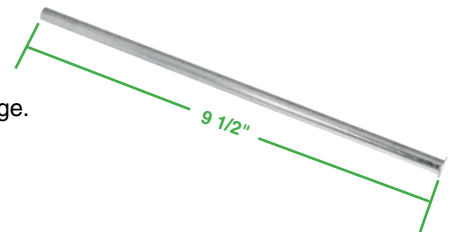

## UNIVERSAL THROTTLE CABLE KIT

Small diameter cable fits thru stock cable tube. Features stock "Dog Leg" on one end and Loop on other. Choose your application...cut off the other. Includes cable adapter. The 15' cable is long enough for most applications.

- 4863** Universal Throttle Cable Kit

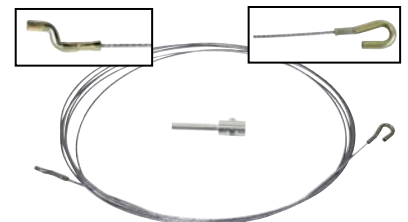



16-9924

## **IRS CLIPS FOR CUSTOM TORSION HOUSING**

Heavy duty IRS clips for custom torsion housing. Sold in pairs with hardware. Welding required.

**16-9924** IRS Clips, Custom Torsion, Pair



17-2675

## **SPRING PLATE CONVERSION KIT**

This kits enables you to remove your stock torsion bars and adapt your housing to heim end trailing arms and coil over shocks. Perfect for that extra travel you are looking for. **(Rod Ends not included)**

**17-2675** Conversion Plate, Stock VW Torsion Housing, 4 pc. Kit Offset to Clear Stock Housing

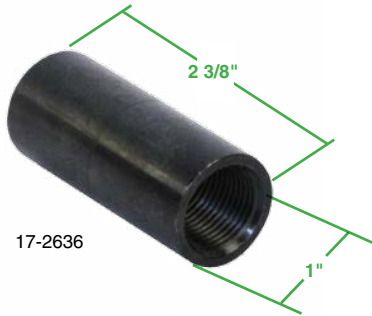

17-2636

## **CHROMOLY THREADED BUNG**

Can be used for a variety of chassis needs. Available in left hand and right hand threads, for 1" tubing.

**17-2635** Threaded Bung, 3/4"-16 Left Hand Thread, 1" x.120 2 3/8" Long, Each

**17-2636** Threaded Bung, 3/4"-16 Right Hand Thread, 1" x.120 2 3/8" Long, Each



17-2698

17-2789

## **TORSION TUBE END PLATES**

Long travel style end plates. Weld on.

**17-2789** Torsion End Plate, Outer, Pair

**17-2698** Torsion End Plate, Inner, Pair



17-2696

17-2697

## **POLISHED STAINLESS TORSION END PLATE**

Polished stainless steel end plates with stainless spacers for IRS torsion.

**17-2696** Torsion End Plate, **Stainless**, Swing Axle, Pair

**17-2697** Torsion End Plate, **Stainless**, I.R.S., Pair



**CHROME AXLE BEARING CAPS**

17-2699 IRS Axle Bearing Cap, Chrome Steel, Fits P/N 17-2707 and 17-2708, Pair

17-2699



**CUSTOM AXLE BEARING HOUSING**

For fabricating IRS trailing arms. Uses stock VW bearings and spacer kits. Aluminum bearing cap 17-2700 sold separate. Holes tapped to 10mm - 1.5 thread.

17-2707 Axle Bearing Housing, IRS, Steel, Each (Boxed)

17-2707



**BILLET AXLE BEARING CAP**

17-2700 IRS Billet Aluminum Bearing Cap for stock application. Fits P/N 17-2707 and 17-2708, Each

17-2700



**BILLET AXLE BEARING HOUSING**

For aftermarket trailing arms. Uses IRS Bearings and seals. Use bearing cap 17-2700 for best results.

17-2708 Billet Aluminum Bearing Housing, IRS, Each (Boxed)

17-2708



**REPLACEMENT SWING AXLE BEARING HOUSINGS**

For 66 and earlier, short axle. Sold in pairs. Bearing not included.

16-9923 Swing Axle Bearing Housing, Pair (Boxed)

16-9923



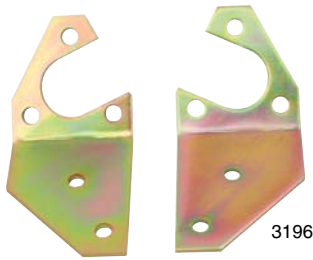

### **SWING AXLE SHOCK MOUNT KIT**

Pre-formed steel plates bolt-on using the rear swing axle flange bolts to provide lower shock mounting points for up to four shocks on custom applications. Not compatible with stock shock mounts.

**3196** Shock Mount Kit, Swing Axle, Pair, Zinc Plated (Bolt-On Installation)



### **I.R.S. SHOCK MOUNT KIT**

Designed for use on stock I.R.S. rear trailing arms that have been boxed, to provide lower mounting points for up to six shocks. Welding required. Not compatible with stock shock mounts.

**3197** Shock Mount Kit w/6 Shock Bushings, I.R.S., Pair, Raw (Requires Welding)

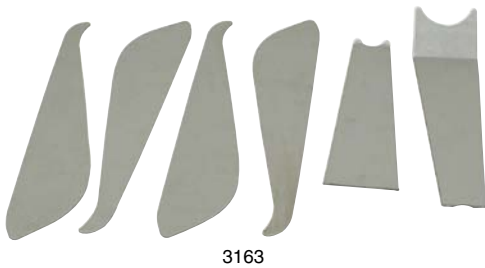

### **I.R.S. BOX KIT**

Strengthen your stock I.R.S. trailing arms with this box and gusset set. Six pre-cut steel pieces weld to the inside back, top and bottom of the stock I.R.S. rear trailing arms greatly improving strength and rigidity. An economical alternative to custom fabricated trailing arms. Not compatible with stock shock mounts. Welding required.

**3163** I.R.S. Box Kit, 6 pcs., Raw



### **I.R.S. CONVERSION CLIPS**

Convert any Swing Axle pan to I.R.S. with these clips. Welding required.

**3164** I.R.S. Conversion Clips, Pair, Raw



### **BUS TRANSMISSION MOUNT**

Weld in front mount brackets for late model bus transmission. Rear bolt mounts and hardware included.

**17-2537** Bus Transmission Mount Kit

**17-2538** Bus Transmission Center Mount Only





## HEAVY DUTY SPRING PLATES (PAINTED)

- 17-2658 Swing Axle for 21 3/4" Bars, Pair (Boxed)
- 17-2660 Swing Axle for 24 11/16" Bars, Pair (Boxed)
- 17-2662 Swing Axle for 26 9/16" Bars, Pair (Boxed)
- 17-2664 IRS Transmission for 21 3/4" Bars, Pair (Boxed)
- 17-2788 IRS Transmission for 24 11/16" Bars, Pair (Boxed)
- 17-2667 IRS Transmission for 26 9/16" Bars, Pair (Boxed)

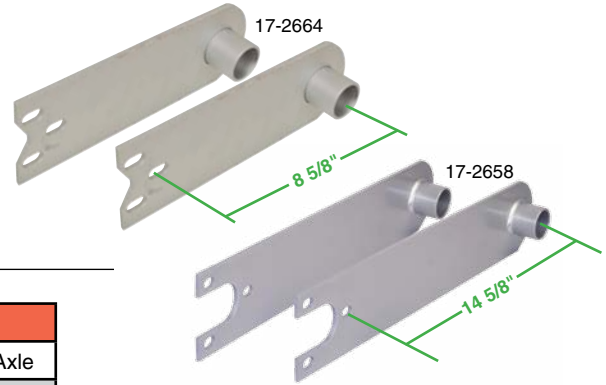

### MODEL YEAR -VS- APPLICATION CHART

SIZE	DESCRIPTION	APPLICATIONS
21 3/4" Long	Short Torsion Bar	60-68 Type 1 Swing Axle
24 11/16" Long	Intermediate Torsion Bar	49-59 Type 1 Swing Axle
24 11/16" Long	Intermediate Torsion Bar	69-72 Type 1 IRS
24 11/16" Long	Intermediate Torsion Bar	65-67 Type 3 Swing Axle
26 9/16" Long	Long Torsion Bar	73 & L Type 1 IRS

NOTE: Measure tube extension past spring plate intermediate 4" long 6".

THE MODEL YEAR VS APPLICATION AND TORSION BAR SPRING RATE CHARTS SHOWN ARE A GUIDELINE ONLY. INDIVIDUAL APPLICATIONS MAY VARY.

## ADJUSTABLE SPRING PLATES (PAINTED)

Adjust your ride height quick and easy.

- 17-2669 Swing Axle for 21 3/4" Bars, Pair (Boxed)
- 17-2670 Swing Axle for 24 11/16" Bars, Pair (Boxed)
- 17-2671 Swing Axle for 26 9/16" Bars, Pair (Boxed)
- 17-2672 IRS Transmission for 21 3/4" Bars, Pair (Boxed)
- 17-2673 IRS Transmission for 24 11/16" Bars, Pair (Boxed)
- 17-2674 IRS Transmission for 26 9/16" Bars, Pair (Boxed)

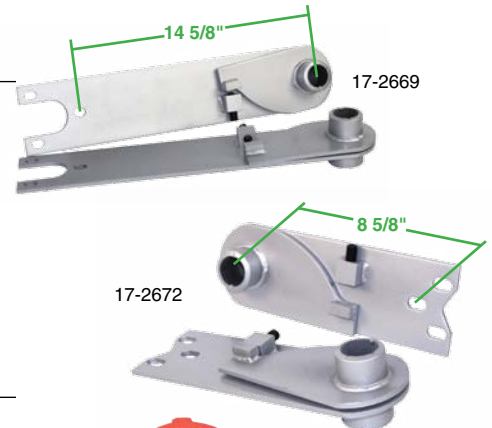

## URETHANE BUSHINGS

The strength and durability of Urethane will out-last and out-perform standard rubber products in every application. From Shift Couplers to Bump Stops, install Urethane and never look back! All urethane is red in color except where noted.

- 16-5130 Urethane Knobby Bushings - 1 3/4" I.D., Pair
- 16-5131 Urethane Knobby Bushings - 1 7/8" I.D., Pair
- 16-5132 Urethane Knobby Bushings - 2" I.D., Pair
- 16-5133 Urethane Smooth Bushings - 1 3/4" I.D., Pair
- 16-5134 Urethane Smooth Bushings - 1 7/8" I.D., Pair



### Urethane Bushing Application Guide

For use with Stock Spring Plates:

Type 1, Swing Axle, 1950-1959:	1 7/8" Round Inner	-	1 7/8" Round Outer
Type 1, Swing Axle, 1960-1968:	1 7/8" Knobby Inner	-	1 3/4" Knobby Outer
Type 1, I.R.S., 1969-1979:	1 7/8" Knobby Inner	-	1 7/8" Round Outer
Type 1, All with Semi-Automatic Trans:	1 7/8" Knobby Inner	-	1 7/8" Round Outer
Type 3, Swing Axle, 1965-1968:	1 7/8" Knobby Inner	-	1 7/8" Knobby Outer
Type 3, I.R.S., 1969-1979:	1 7/8" Knobby Inner	-	1 7/8" Round Outer

For Use with Aftermarket Spring Plates Listed on this Page:

The tubes welded on the spring plates are different than stock. The O.D. of the inner tube is also different than the O.D. of the outer tube.

- Non-Adjustable Spring Plates: 1 3/4" O.D. on Inner Tube - 1 7/8" O.D. on Outer Tube
- Adjustable Spring Plates: 2" O.D. on Inner Tube - 1 7/8" O.D. on Outer Tube

## LIMIT STRAPS

Limiting suspension travel to a functional distance, cuts down on CV joint, axle, and boot wear. Single or Double Straps...Available from 12" to 32" in 2" increments. Black strap with Gold Zinc ends.

17-2683	Straps 12", Pair
17-2684	Straps 14", Pair
17-2685	Straps 16", Pair
17-2686	Straps 18", Pair
17-2687	Straps 20", Pair
17-2863	Straps 22", Pair
17-2688	Straps 24", Pair
17-2864	Straps 26", Pair
17-2865	Straps 28", Pair
17-2866	Straps 30", Pair
17-2867	Straps 32", Pair



For extreme applications, heavy vehicles or just added support, double-up with these Double Limit Straps...**Double the thickness of material for double strength.**



17-2890	Double Straps 12", Pair
17-2891	Double Straps 14", Pair
17-2892	Double Straps 16", Pair
17-2893	Double Straps 18", Pair
17-2894	Double Straps 20", Pair
17-2895	Double Straps 22", Pair
17-2896	Double Straps 24", Pair
17-2897	Double Straps 26", Pair
17-2898	Double Straps 28", Pair
17-2899	Double Straps 30", Pair
17-2900	Double Straps 32", Pair



## LIMIT STRAP CLEVIS

Perfect for installing limit straps. The spring loaded rod makes for easy adjustment. Use with our 17-2682 weld on chassis mount.



17-2682

17-2681	Clevis, Limit Strap, Chrome, Pair
17-2682	Forged Clevis Mount, <b>MUST BE WELDED</b> , Pair

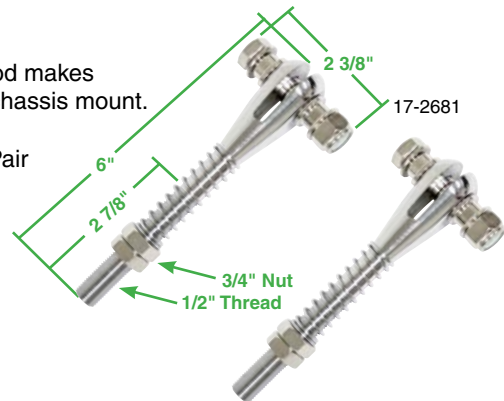

## CHROMOLY TAPERED BUNGS

Used mainly for fabricating tie rods on off road applications. Available in 4 different tubing sizes and left or right hand thread.

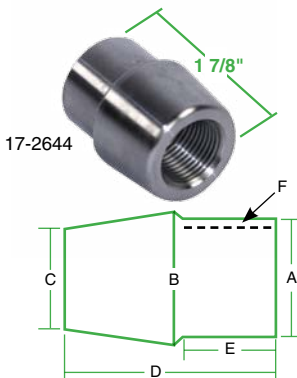

17-2644

		THREAD	A	B	C	D	E	F
17-2637	Bung, Tapered Chromoly,	5/8"-18 L/H	0.78	0.98	0.86	1.70	0.78	0.095
17-2638	Bung, Tapered Chromoly,	5/8"-18 R/H	0.78	0.98	0.86	1.70	0.78	0.095
17-2639	Bung, Tapered Chromoly,	3/4"-16 L/H	1.05	1.23	1.00	1.75	0.74	0.095
17-2640	Bung, Tapered Chromoly,	3/4"-16 R/H	1.05	1.23	1.00	1.75	0.74	0.095
17-2641	Bung, Tapered Chromoly,	3/4"-16 L/H	1.00	1.23	1.00	1.75	0.65	0.120
17-2642	Bung, Tapered Chromoly,	3/4"-16 R/H	1.00	1.23	1.00	1.75	0.65	0.120
17-2643	Bung, Tapered Chromoly,	7/8"-14 L/H	1.25	1.48	1.32	1.87	0.74	0.095
17-2644	Bung, Tapered Chromoly,	7/8"-14 R/H	1.25	1.48	1.32	1.87	0.74	0.095



# Race Trim® HI-BACK SEATS

## LOW-BACK ROADSTER STYLE SEATS

Low-Back Roadster-Style Seat with a Steel Tube Frame, comfortable foam padding with good lateral and thigh support and a fixed back (no recline), finished in Black Vinyl, Low design that is perfect for Buggies, Kit Cars, VWs and other applications where a super- short seat height is of benefit.



**62-2880** **NEW!** Low-Back Roadster-Style Seat, Black, Each

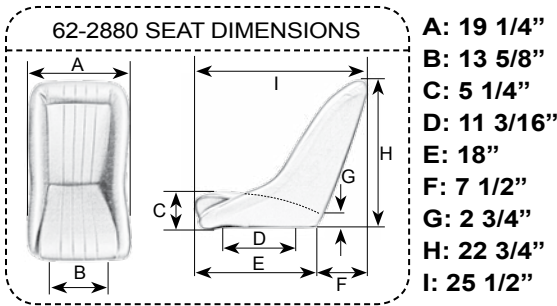

**62-2880 and 62-2881 are Universal and do not come with brackets or adaptors, so remember that each application will require custom fitment. Covers are not replacable. This seat has four (4) 8mm x 1.25 female threaded inserts on the bottom.**

## LOW-BACK ROADSTER STYLE SEATS W/ POLISHED VENT GROMMETS

Low-Back Roadster-Style Seat with a Steel Tube Frame, comfortable foam padding with good lateral and thigh support and a fixed back (no recline), finished in Black Vinyl with Polished Vent Grommets, Low design that is perfect for Buggies, Kit Cars, VWs and other applications where a super- short seat height is of benefit.



**62-2881** **NEW!** Low-Back Roadster-Style Seat, Black w/ Polished Vent Grommets, Each

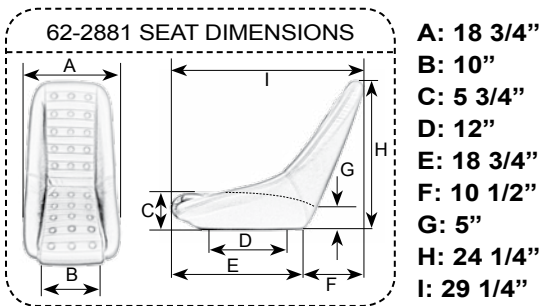

**Race Trim® HI-BACK SEATS**

**62-2777** Black Leather Look Vinyl w/ Carbon Fiber Look Accents

**Features:**

- New look and feel of leather with the durability of vinyl
- Carbon Fiber look accents
- Fully welded and painted steel frame construction
- Dense foam cushioning
- Weather-proof suspended bladder
- Rigid suspension straps
- 5-Point seat belt slots accept all latch-style belts
- Standard tab style mount point
- Classic square stitch style
- Fixed headrest integrated into frame
- Mounting kits and sliders, see page 402



**Carbon Fiber Look Accents**



**The Look & Feel of Leather**

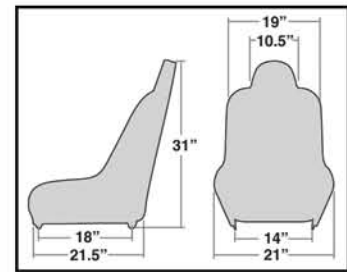

**Dimensions:**

- Overall width: 21"
- Overall height: 31" (Includes tabs)
- Shoulder width: 19"
- Mounting point side to side: 14"
- Mounting point front to back: 18"

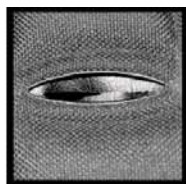

Crotch slot accepts anti-submarine belts



4-Point standard mounting tabs



Grommets away from frame eliminates contact wear

Race Trim seats and products are for off-road vehicles only, not intended for street or highway use



## Race Trim<sup>®</sup> HI-BACK SEATS

- 62-2750 Black Vinyl / Tweed Fabric
- 62-2751 Black Vinyl / Black Fabric
- 62-2752 Black Vinyl / Black Vinyl
- 62-2759 Grey Vinyl / Grey Fabric

**62-2750**

### Features:

- Fully welded and painted steel frame construction
- Dense foam cushioning
- Weather-proof suspended bladder
- Rigid suspension straps
- 5-Point seat belt slots accept all latch-style belts
- Standard tab style mount point
- Classic square stitch style
- Fixed headrest integrated into frame
- Mounting kits and sliders, see page 402

### Dimensions:

Overall width: 21"  
 Overall height: 31" (Includes tabs)  
 Shoulder width: 19"  
 Mounting point side to side: 14"  
 Mounting point front to back: 18"

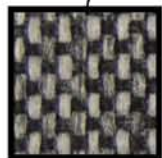
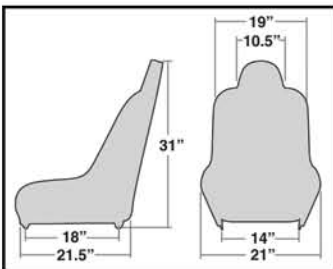

Fabric



Crotch slot accepts anti-submarine belts



4-Point standard mounting tabs

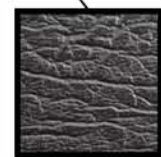

Vinyl



Grommets away from frame eliminates contact wear



Race-Trim seats and products are for off-road vehicles only, not intended for street or highway use

## Race Trim® WIDE HI-BACK SEATS

- 62-2794 Black Vinyl / Black Fabric
- 62-2795 Black Vinyl / Black Vinyl
- 62-2796 Grey Vinyl / Grey Fabric

**62-2794**

### Features:

- Extra wide dimension for more relaxed fit
- Two (2) inches wider than standard Hi-Back seat
- Fully welded and painted steel frame construction
- Dense foam cushioning
- Weather-proof suspended bladder
- Rigid suspension straps
- 5-Point seat belt slots accept all latch-style belts
- Standard tab style mount point
- Classic square stitch style
- Fixed headrest integrated into frame
- Mounting kits and sliders, see page 402

### Dimensions:

- Overall width: 23"
- Overall height: 31" (Includes tabs)
- Shoulder width: 21"
- Mounting point side to side: 16"
- Mounting point front to back: 18"

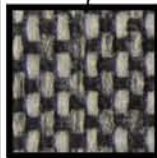
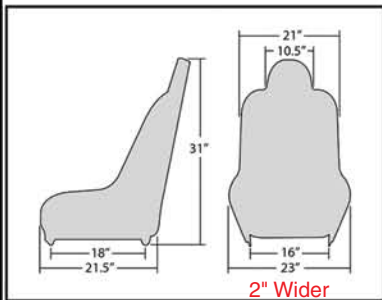

Fabric



Crotch slot accepts anti-submarine belts



4-Point standard mounting tabs

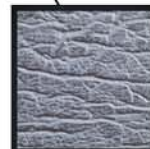

Vinyl



Grommets away from frame eliminates contact wear



**62-2794**



**62-2795**  
100% Vinyl



**62-2796**

Race-Trim seats and products are for off-road vehicles only, not intended for street or highway use



## Race Trim<sup>®</sup> WIDE LOW-BACK SEATS WITH ADJUSTABLE HEADREST

- 62-2766 Black Vinyl / Tweed Fabric
- 62-2767 Black Vinyl / Black Fabric
- 62-2768 Black Vinyl / Black Vinyl
- 62-2769 Grey Vinyl / Grey Fabric

**62-2768**

100% Vinyl  
Contemporary  
Stitch Pattern

### Features:

- Extra wide dimension for more relaxed fit
- Two (2) inches wider than standard Hi-Back seat
- Fully welded and painted steel frame construction
- Dense foam cushioning
- Weather-proof suspended bladder
- Rigid suspension straps
- 5-Point seat belt slots accept all latch-style belts
- Standard tab style mount point
- Classic square stitch style - on all fabric
- 2 way adjustable headrest
- [Mounting kits and sliders, see page 402](#)



Adjustable Headrest  
(Up/down/angle)



### Dimensions:

- Overall width: 24"
- Overall height: 23"  
(Includes tabs, without headrest)
- Shoulder width: 22"
- Mounting point side to side: 16"
- Mounting point front to back: 18"

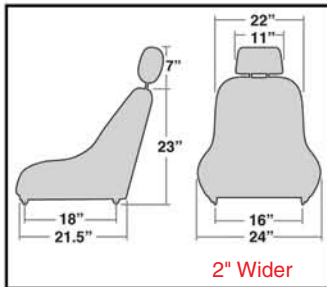

Crotch slot accepts  
anti-submarine belts



4-Point standard mounting tabs



Vinyl



Grommets away from  
frame eliminates  
contact wear



Race-Trim seats and products are for off-road vehicles only, not intended for street or highway use

## Race Trim CHILD SEAT

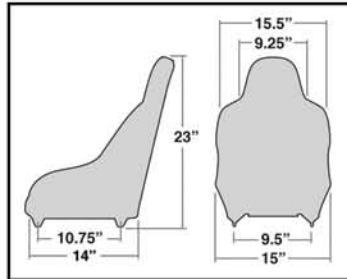

**62-2771**

**62-2771** Black Vinyl / Black Fabric

### Features:

- Fully welded and painted steel frame construction
- Dense foam cushioning
- Weather-proof suspended bladder
- Rigid suspension straps
- 5-Point seat belt slots accept all latch-style belts
- Standard tab style mount point
- Classic square stitch style

### Dimensions:

- Overall width: 15"
- Overall height: 23" (Includes tabs)
- Shoulder width: 15.5"
- Mounting point side to side: 9.5"
- Mounting point front to back: 10.75"

### RACE-TRIM SEAT MATERIAL

Making a bench back seat? Ice cooler cover? Or maybe a repair. The same quality material used on our race suspension seats is available in bulk sections. 1.4M x 1M (50" x 40") for the perfect match.

- |                |                                       |
|----------------|---------------------------------------|
| <b>62-2753</b> | Black Vinyl, 1.4M Wide x 1M Long      |
| <b>62-2754</b> | Black Cloth, 1.4M Wide x 1M Long      |
| <b>62-2755</b> | Tweed Cloth, 1.4M Wide x 1M Long      |
| <b>62-2756</b> | Tan Cloth, 1.4M Wide x 1M Long        |
| <b>62-2757</b> | Tan Vinyl, 1.4M Wide x 1M Long        |
| <b>62-2758</b> | Light Grey Cloth, 1.4M Wide x 1M Long |
| <b>62-2749</b> | Light Grey Vinyl, 1.4M Wide x 1M Long |
| <b>62-2748</b> | New Black Vinyl, 1.4M Wide x 1M Long  |



62-2753

### RACE-TRIM SHOWROOM SEAT DISPLAY

Dress up your show room with a Race-Trim seat mounted to an attractive seat display. Perfect for a "Test Sit". Display fits most seat sizes and types. The universal design will fit all Jeep® Seats High and Low Back. It will also fit all front Off-Road Seats, excluding Child and Rhino Seats. Complete with hardware and black finish.



62-2470

**62-2470** Race-Trim Showroom Seat Display w/ Hardware - Painted Black



Race-Trim seats and products are for off-road vehicles only, not intended for street or highway use





## Race Trim<sup>®</sup> REAR BENCH SEATS WITH ADJUSTABLE HEADREST

### 48" REAR BENCH SEAT

- 62-2806 Black Vinyl / Tweed Fabric
- 62-2807 Black Vinyl / Black Fabric
- 62-2808 Grey Vinyl / Grey Fabric
- 62-2809 Tan Vinyl / Tan Fabric

**62-2808**

### 51" REAR BENCH SEAT

- 62-2810 Black Vinyl / Tweed Fabric
- 62-2811 Black Vinyl / Black Fabric
- 62-2812 Grey Vinyl / Grey Fabric
- 62-2813 Tan Vinyl / Tan Fabric

**SHIPPED BY TRUCK ONLY**

#### Features:

- Extra wide dimension for more relaxed fit
- Fully welded and painted steel frame construction
- Dense foam cushioning
- Weather-proof suspended bladder
- Rigid suspension straps
- 5-Point seat belt slots accept all latch-style belts
- Standard tab style mount point
- Classic square stitch style - on all fabric
- 2 way adjustable headrest

#### Dimensions:

- Overall width: 48"
- Overall height: 25"  
(Includes tabs, without headrest)
- Shoulder width: 46"
- Mounting point side to side: 41"
- Mounting point front to back: 14.75"

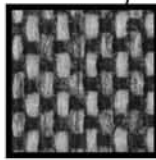

Fabric



Crotch slot accepts anti-submarine belts



4-Point standard mounting tabs

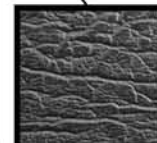

Vinyl



Grommets away from frame eliminates contact wear



Adjustable Headrest (Up/down/angle)

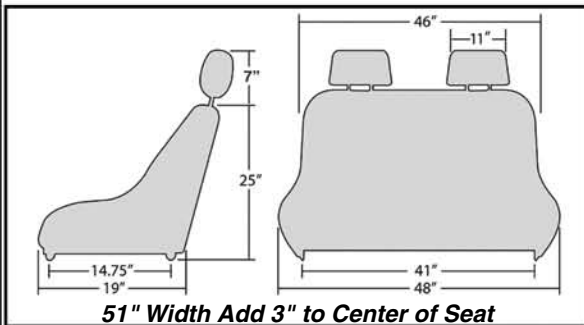

**62-2806**



**62-2807**



**62-2809**

Race-Trim seats and products are for off-road vehicles only, not intended for street or highway use

## RACE-TRIM SEAT MOUNTS & SLIDERS

Race-Trim makes it easy to mount their seats or other seats into most any application with these universal mounts and sliders. Mounts are designed to raise the seat approx. 4 inches (low mount) or 6 inches from the floor surface. Choose from a slider only for driver/passenger or slider on the driver side and tilt for the passenger side. Mount kits come complete with the slider mechanism where applicable. Sliders are available for custom applications where you want to fabricate your own mounting arrangement. Slider only's are supplied as a per seat set.

**62-2640** Universal Seat Slider Only, Pr. (1-seat)

**62-2641** Universal Seat Slider & Mounting Plate, Pr. (1-seat)

**62-2644** Seat Mount Kit, Slide/Slide, 6", Pr.

**62-2645** Seat Mount Kit, Slide/Tilt, 6", Pr. (Cannot use on wide seats.)

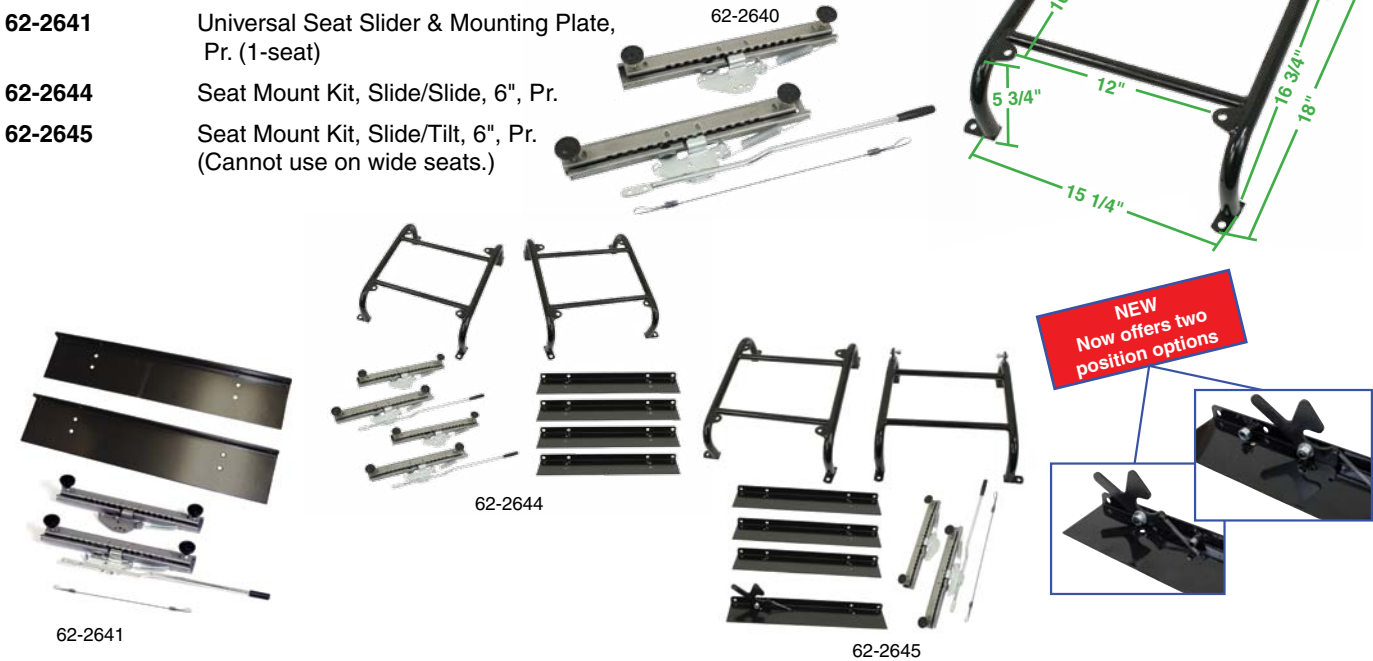

## RACE-TRIM LOW MOUNT SEAT MOUNTS

Mounts are designed to raise the seat approx. 4 inches (Low mount) from the floor surface. See above for sliders only.

**62-2655** **NEW!** Seat Mount Kit, Slide/Tilt, 4" (Low Mount), Pr. (Cannot use on wide seats.)

**62-2656** **NEW!** Seat Mount Kit, Slide/Slide, 4" (Low Mount), Pr.



Race Trim seats and products are for off-road vehicles only, not intended for street or highway use



# OFF-ROAD – UTV/SIDE X SIDE

## RaceTrim® UTV/SIDE x SIDE SEATS



**62-2815**

**SEATS SHIPPED BY TRUCK ONLY**

### 42" UTV/SIDE x SIDE REAR BENCH W/ ADJ. HEADRESTS

- 62-2814 Black Vinyl / Black Fabric
- 62-2815 Grey Vinyl / Grey Fabric
- 62-2818 Black Vinyl / Black Vinyl

62-2822 Mount for 42" Seat, Each  
(See Page 404)

Fits Yamaha Rhino®

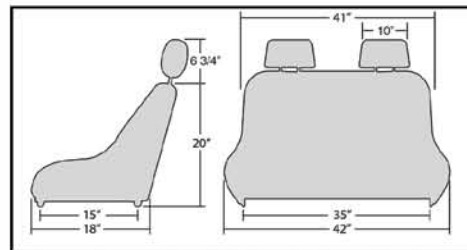

#### Features:

- Fully welded and painted steel frame construction
- Dense foam cushioning
- Weather-proof suspended bladder
- Rigid suspension straps
- Standard tab style mount point
- Classic square stitch style

#### 42" UTV Rear Bench Dimensions:

Overall width: 42"  
 Overall height: 20"  
 (Includes tabs, without headrest)  
 Shoulder width: 41"  
 Mounting point side to side: 35"  
 Mounting point front to back: 42"



62-2822 Bench Mount  
(See Page 404)



Adjustable Headrest  
(Up/down/angle)



**62-2817**

### UTV/SIDE x SIDE LOW BACK W/ ADJ. HEADRESTS



- 62-2816 Black Vinyl / Black Fabric
- 62-2817 Grey Vinyl / Grey Fabric
- 62-2820 Black Vinyl / Black Vinyl

Comes With Mounting Hardware

Fits Yamaha Rhino® and ArcticCat Prowler®

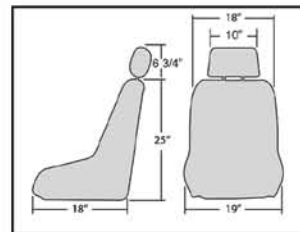

#### UTV Low Back Dimensions:

Overall width: 19"  
 Overall height: 25"  
 (Includes tabs, without headrest)  
 Shoulder width: 18"  
 Mounting point side to side: 15"  
 Mounting point front to back: 13"



Hardware

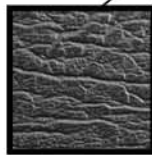

Vinyl



Fabric

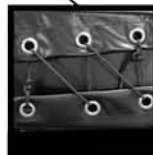

Grommets away from frame eliminates contact wear

Yamaha Rhino and ArcticCat Prowler are registered trademarks of Yamaha and ArcticCat  
 Race-Trim seats and products are for off-road vehicles only, not intended for street or highway use

## RHINO ACCESSORIES & PARTS

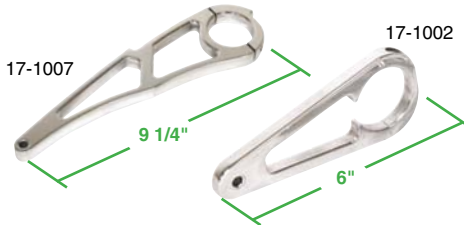

### ALUMINUM MIRROR BRACKET

The perfect compliment to our P/N 16-8580 3-Panel Mirror.

**17-1002**  
**17-1007**

Polished Aluminum Mirror Bracket, For Stock Cage, Pr.  
Polished Aluminum Mirror Bracket, For 1 1/2" Cage, Pr.



### ALUMINUM SHIFT KNOB

Accent your Rhino interior with this billet shift knob.

**17-1005**

Polished Aluminum Shift Knob for Rhino, Each



### ALUMINUM RADIO PLATE

Replace the stock dash insert in your Rhino with this trick aluminum piece.

**17-1006**

Polished Aluminum Radio Plate for Rhino, Each



### RACE-TRIM MOUNT FOR RHINO 42" BENCH SEAT

This mount is specifically designed to mount our 42" Rear Bench Seats in Rhino vehicles. The side rails secure to the bed and have an extra mounting hole at the rear to prevent the seat from tilting forward. Four seatbelt tabs are welded to the mount for using two seat belts. Mounting hardware included. [For seats, see page 403.](#)

**62-2822**

Mount for Rhino 42" Bench Seat, Ea.

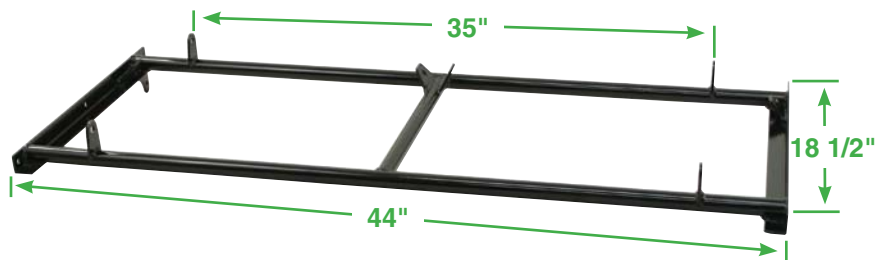
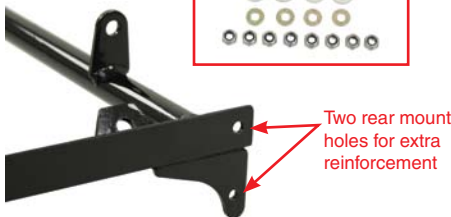

### RHINO HARNESS BAR

Our new Rhino Harness Bar is designed to use with or without the standard headrest. Features include loops to facilitate the use of a 4-Point harness and convenient tab for mounting a buggy-whip antenna.

**17-1010**

Harness Bar for Rhino, 04-06 +

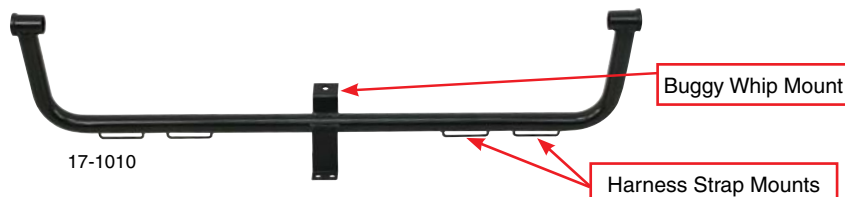



## POLY BUCKET SEATS AND COVERS

EMPI's super strong double walled polyethylene High and Low Back Seats just got better. The seat and back areas have been re-contoured for added comfort and lumbar support. The finish has been upgraded for a great show car look. EMPI seats feature a strong double wall shell, contemporary design, permanent-mounting inserts molded into the base, slots for seat belts and shoulder straps. Use without seat covers for low maintenance or add our thickly padded high grade vinyl covers in black or assorted colors with (2) snap fasteners for that one-off custom look and added comfort. Seat covers now come with two harness slots making them usable on many manufacturers' poly seats. New tooling with EMPI molded into the plastic. Now uses 6 - 10mm x 1.5 threaded inserts.



62-2310

62-2353

62-2350

62-2351

62-2352



## POLY HIGH BACK SEATS

- 62-2300 High Back Poly Comfort Seat
- 62-2310 Seat Cover, Black w/Square Pattern, Each
- 62-2350 Seat Cover, Black/Yellow w/Square Pattern, Each
- 62-2351 Seat Cover, Black/Red w/Square Pattern, Each
- 62-2352 Seat Cover, Black/Blue w/Square Pattern, Each
- 62-2353 Seat Cover, Black/Grey w/Square Pattern, Each



2 Harness Slots in High Covers



Snap Fasteners

## POLY LOW BACK SEATS

- 62-2400 Low Back Poly Comfort Seat
- 62-2408 Seat Cover, Black w/Square Pattern, Each
- 62-2409 **NEW!** Seat Cover, Black/Yellow w/Square Pattern, Each
- 62-2410 **NEW!** Seat Cover, Black/Red w/Square Pattern, Each
- 62-2411 **NEW!** Seat Cover, Black/Blue w/Square Pattern, Each
- 62-2412 **NEW!** Seat Cover, Black/Grey w/Square Pattern, Each



62-2408



62-2409

62-2410

62-2411

62-2412

**NEW!**

**NEW!**

**NEW!**

**NEW!**

Race-Trim seats and products are for off-road vehicles only, not intended for street or highway use

## PLASTIC BUCKET SEATS AND COVERS

Far superior to fiberglass versions, these plastic seats are made from high impact plastic. For additional comfort use our custom pre-made diamond or square pattern seat covers. Covers are also available in colored square pattern, and have a draw string for easy removal. (Note: Seat covers will also fit fiberglass seats.)



### PLASTIC LOW BACK SEAT & COVERS

- 62-2600** Plastic Low Back Seat
- 3880** Seat Cover, Black Diamond Pattern, Each
- 3882** Seat Cover, Black Square Pattern, Each
- 62-2610** Seat Cover, Black/Yellow Square Pattern, Each
- 62-2611** Seat Cover, Black/Red Square Pattern, Each
- 62-2612** Seat Cover, Black/Blue Square Pattern, Each
- 62-2613** Seat Cover, Black/Grey Square Pattern, Each
- 62-2603** Seat Foam Kit for P/N: 62-2600 Style Seat, Each

## FIBERGLASS SEATS & COVERS

Our Fiberglass seats are made from heavy mat and finished with a durable gel coat. They are adaptable to a wide range of applications. For comfort and safety we strongly recommend that our custom pre-made covers be used. Covers are available in black vinyl with a diamond or square pattern and have a draw string for easy removal.



### HIGH BACK SEAT COVERS

- 3859** Seat Cover, Black Square Pattern

### LAY-BACK SEAT COVERS

- 3861** Seat Cover, Black Square Pattern

### BUGGY REAR FIBERGLASS BENCH SEAT

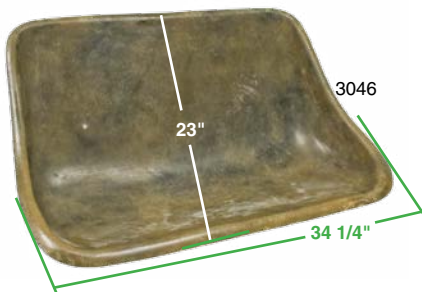

- 3046** Rear Bench Seat, 34 1/4" Widest Point, 23" Top to Bottom (End to End Lengths)
- 3047** Rear Bench Seat, 37 3/4" Widest Point, 23" Top to Bottom (End to End Lengths)
- 3059** Seat Cover, Black Diamond, 34 1/4" (Base @ Seam 27 1/2")
- 3061** Seat Cover, Black Diamond, 37 3/4" (Base @ Seam 31")



3046 with 3059 Cover



### REAR WELL & CARGO AREA CARPET KITS

Matching carpet to cover the rear wheel well and cargo area behind the rear seat - or, with the Baja Bug Kit - carpet the rear area having taken the seat out.

- 3075** 54-77 Baja Bug Sedan Rear Well Carpet Kit, 4-Piece, Black Covers back seat and cargo area including wheel wells when rear seat has been removed.

Race-Trim seats and products are for off-road vehicles only, not intended for street or highway use



**CROW DRIVER RESTRAINT SYSTEMS**

Crow Enterprise Driver Restraint Systems are SFI Approved (SFI-16.1) and feature Latch & Link with built-in Latch Guard, Lap Belt Pull Down adjustment and are offered in different styles and colors. (Not for Competition Use)



**CROW 3x3 SYSTEM WITH Y-TYPE HARNESS**

System with 50" Floor Mount Seat Belt (Bolt-In), Y-Type Floor Mount Harness and Anti-Sub Belt (Bolt-In). (Not for Competition Use)

- 3964 3" Lap Belt, 3" Y Harness, Anti-Sub, Blue
- 3965 3" Lap Belt, 3" Y Harness, Anti-Sub, Red
- 3966 3" Lap Belt, 3" Y Harness, Anti-Sub, Black
- 3967 3" Lap Belt, 3" Y Harness, Anti-Sub, Grey

**CROW 3x3 SYSTEM WITH V-TYPE HARNESS**

System with 50" Floor Mount Seat Belt (Bolt-In), V-Type Bolt-In Mount Harness and Anti-Sub Belt (Bolt-In). (Not for Competition Use)

- 3968 3" Lap Belt, 3" V Harness, Anti-Sub, Blue
- 3969 3" Lap Belt, 3" V Harness, Anti-Sub, Red
- 3970 3" Lap Belt, 3" V Harness, Anti-Sub, Black
- 3971 3" Lap Belt, 3" V Harness, Anti-Sub, Grey

**CROW 3x3 SYSTEM WITH TWIN HARNESS**

System with 50" Floor Mount Seat Belt (Bolt-In), Individual Twin Bolt-In Harness and Anti-Sub Belt (Bolt-In). (Not for Competition Use)

- 3972 3" Lap Belt, 3" Twin Harness, Anti-Sub, Blue
- 3973 3" Lap Belt, 3" Twin Harness, Anti-Sub, Red
- 3974 3" Lap Belt, 3" Twin Harness, Anti-Sub, Black
- 3975 3" Lap Belt, 3" Twin Harness, Anti-Sub, Grey

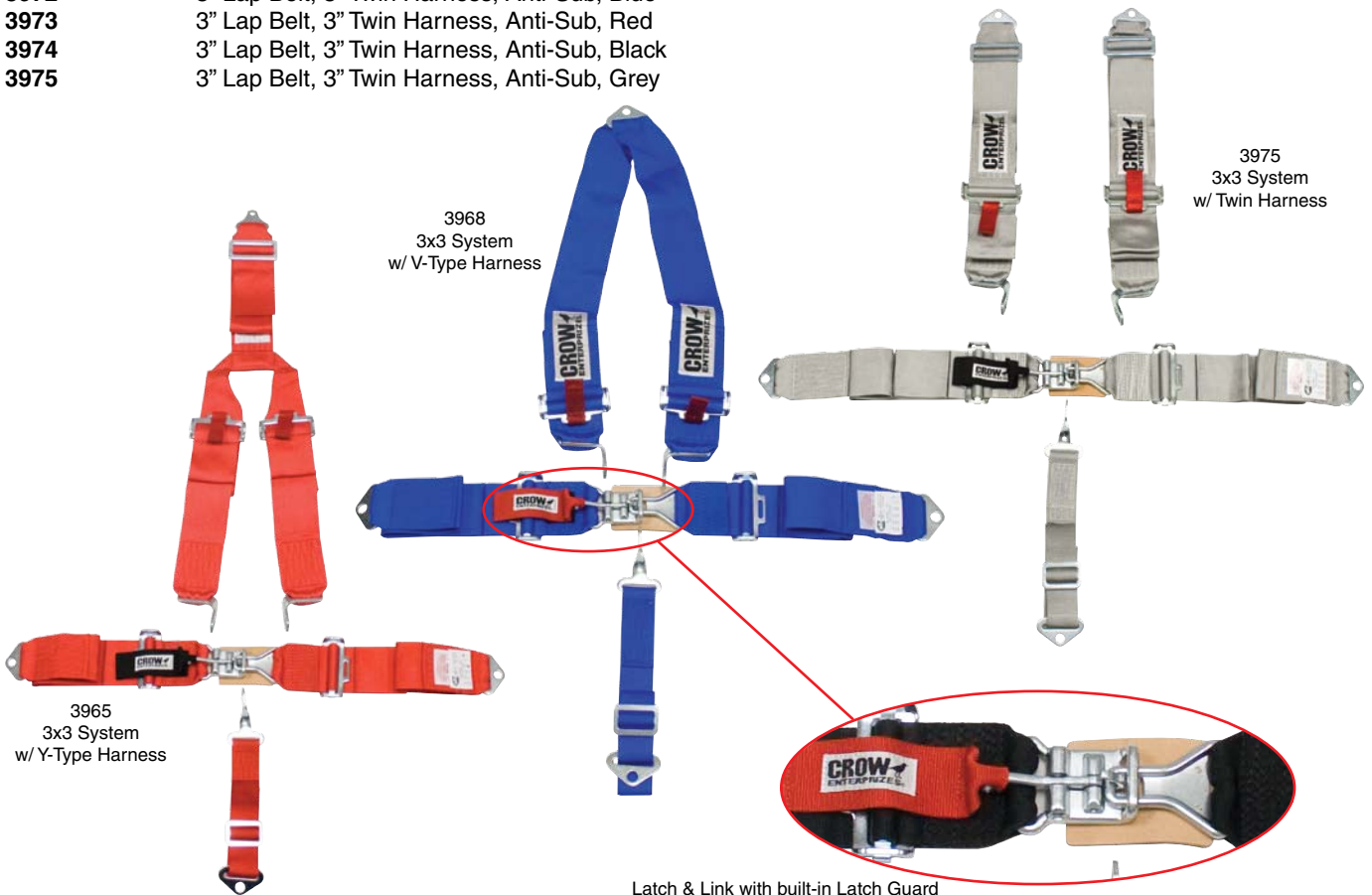

Latch & Link with built-in Latch Guard



3979



### CROW 3x2 SYSTEM WITH Y WRAP-AROUND HARNESS

3" 50" Floor Mount Seat Belt (Bolt-In) and Y-Type Wrap Around Harness. Not SFI Approved. (Not for Competition Use)

- 3976** 3" Lap Belt, 2" Y Wrap-Around Harness, Blue (Not for Competition Use)
- 3977** 3" Lap Belt, 2" Y Wrap-Around Harness, Red (Not for Competition Use)
- 3978** 3" Lap Belt, 2" Y Wrap-Around Harness, Black (Not for Competition Use)
- 3979** 3" Lap Belt, 2" Y Wrap-Around Harness, Grey (Not for Competition Use)

**NEW!**

3900



### CROW 3x2 4-POINT SYSTEMS

3" 50" Floor Mount Seat Belt (Bolt-In) with either a Y-Type Bolt-In Harness or Individual Twin Bolt-In Harness. (Not for Competition Use)

- 3900** **NEW!** 3" x 2" 4-Point System with 2" Y-Type Bolt-In Harness  
50" Floor Mount (Bolt-In), Black, Each (Not for Competition Use)
- 3901** **NEW!** 3" x 2" 4-Point System with Individual 2" Twin Bolt-In Harness  
50" Floor Mount (Bolt-In), Black, Each (Not for Competition Use)

**NEW!**

3901



3989



### CROW 2" SEAT BELT & HARNESS ASSEMBLY

Combination Standard-Style Seat Belt with Buckle and a sewn-in Shoulder Harness made of OEM type material. Great for fun buggies and other slow-mph applications. Not SFI Approved. (Not for Competition Use)

- 3989** 2" x 2" Lap Belt W/Standard Seat Buckle w/Y Harness (Wrap Around), Black Only (Not for Competition Use)



Sewn-in Shoulder Harness  
3989



## CROW SAFETY GEAR

### CROW 3" LAP BELTS

Snap-In Belt or Bolt-In Belt. (Not for Competition Use)

**3902** **NEW!** 3" Lap Belt Only, Snap-In, 50" Foot Mount, Black, Each  
(Not for Competition Use)



**3903** **NEW!** 3" Lap Belt Only, Bolt-In, 50" Floor Mount, Black, Each  
(Not for Competition Use)



### CROW 2" SHOULDER HARNESS

V-Type Bolt-In Harness, Y-Type Wrap-Around Harness or Individual Twin Bolt-In Harness  
(Not for Competition Use)

**3904** **NEW!** 2" Shoulder Harness only, V-Type Bolt-In Mount, Black Each  
(Not for Competition Use)

**3905** **NEW!** 2" Shoulder Harness only, Y-Type Wrap-Around Mount, Black, Each  
(Not for Competition Use)

**3906** **NEW!** 2" Shoulder Harness only, Individual Twin Bolt-In Mount, Black, Each  
(Not for Competition Use)



### CROW ANTI-SUBMARINE BELT

Helps prevent lap belts from moving, changing position or becoming loose. Used with Latch & Link systems. (Not for Competition Use)

**3985** 2" Anti-Sub Belt Only, Blue

**3986** 2" Anti-Sub Belt Only, Red

**3987** 2" Anti-Sub Belt Only, Black

**3988** 2" Anti-Sub Belt Only, Grey

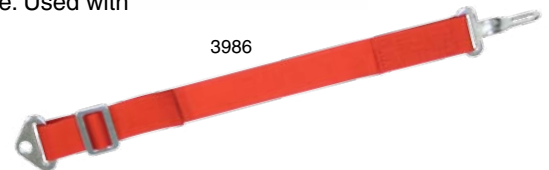

### CROW BELT & HARNESS HARDWARE

**3920** **NEW!** Snap (Flat) & Eye Bolt Kit

**3921** **NEW!** Eye Bolt Kit (2 Sets)

**3922** **NEW!** Flat 2" Snap, Pair

**3923** **NEW!** 3-Bar Slide, 2", Pair

**3924** **NEW!** 3-Bar Slide, 3", Pair



# CROW SAFETY GEAR

## MOUNTING BRACKETS

Mounting brackets should be installed at an angle that is compatible with the direction of pull on the webbing under full load.

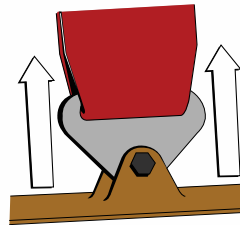
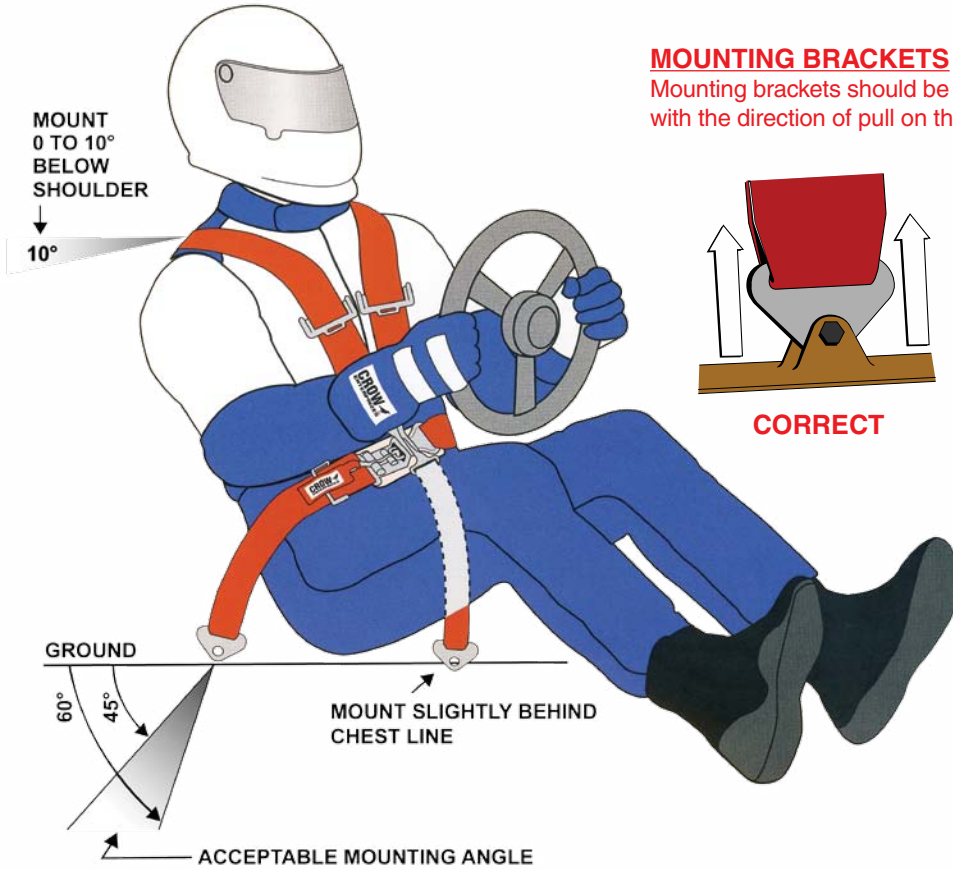

**CORRECT**

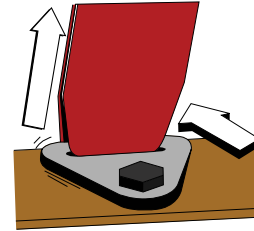

**INCORRECT**



**FOLD BOTH CORNERS**



**INSERT FOLDED END INTO HARDWARE**



**PULL THRU AND CONTINUE**



**SHOULD LOOK LIKE THIS**

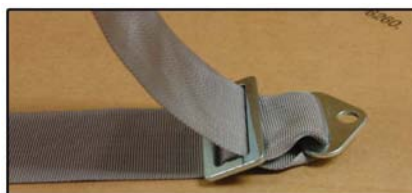

**PULL THRU 3 BAR SLIDE**



**SHOULD LOOK LIKE THIS**



**BILLET SIDE & REAR VIEW BUGGY MIRRORS**

Let EMPI help you hit the dunes in style with these Polished Billet Aluminum Side and Rear View Mirrors. Available with quick clamp on mount or radiused base screw on mount.

**SIDE VIEW MIRRORS**

- 16-8571** Side View, Rectangular, End Pin Clamp On Mirror for 1 1/2" Tubing, 2" x 3 1/2" Mirror
- 16-8573** Side View, Rectangular, End Pin Radius/Screw Mount Mirror for 1 1/2" Tubing, 2" x 3 1/2" Mirror



**REAR VIEW MIRRORS**

- 16-2047** Rear View, Rectangular, Center Pin Clamp On Mirror for 1 1/2" Tubing, 2" x 5" Mirror
- 16-8572** Rear View, Rectangular, Center Pin Radius/Screw Mount Mirror for 1 1/2" Tubing, 2" x 5" Mirror

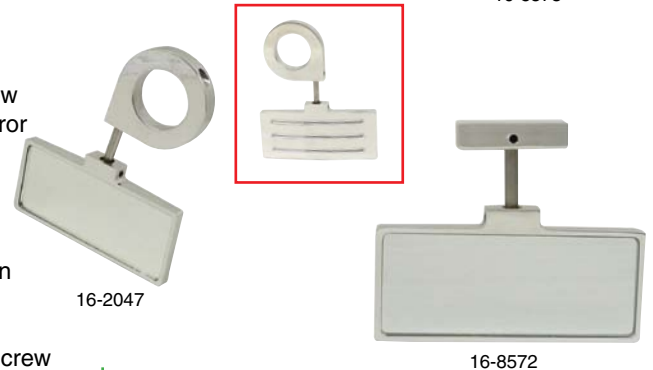

**5-PANEL REAR VIEW MIRROR**

- 4580** 5-Panel Mirror, Complete with Hardware

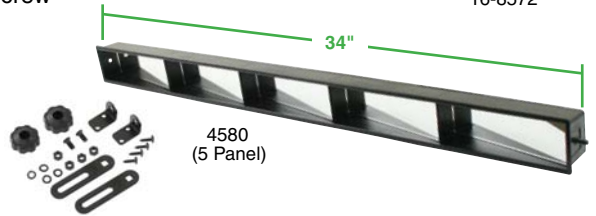

**3, 4 & 5 PANEL BILLET ALUMINUM REAR VIEW MIRRORS**

- 16-8580** Aluminum 3-Panel R/V Mirror, 18" Wide
- 16-8581** Aluminum 4-Panel R/V Mirror, 24" Wide
- 16-8582** Aluminum 5-Panel R/V Mirror, 30" Wide

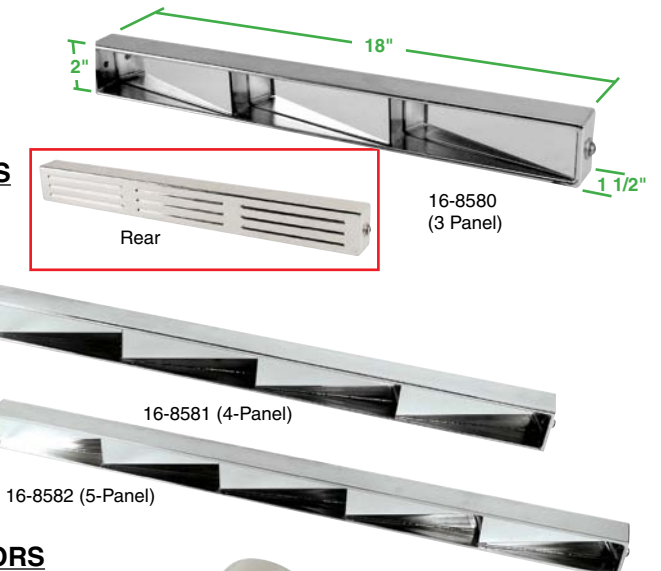

**BILLET MOUNTS FOR 3, 4 & 5 PANEL REAR VIEW MIRRORS**

- 16-8585** Aluminum Mirror Mount, 1 1/2" Radius, Pair
- 16-8587** Aluminum Mirror Mount, Flat, Pair
- 16-8586** Aluminum Mirror Mount, Clamp on for 1 1/2" Tubing, Pair





9310



9309



16-9150



## EMPI CHROME OFF-ROAD LIGHTS

Great looks and added night vision make these lights a must on any Baja or Buggy. Your choice of 5" or 6", complete with H3 12-Volt 100 Watt bulb or a 4" mini-version with H3 12-Volt 55 Watt bulb. All lights come complete with mounting hardware and attractive EMPI display packaging. **(Off-Road Use Only)**

- 16-9150
- 9309
- 9310

- Chrome Off-Road Light 4", Each (Boxed)
- Chrome Off-Road Light 5", Each (Boxed)
- Chrome Off-Road Light 6", Each (Boxed)



16-9148

## EMPI LIGHT COVERS FOR CHROME OFF-ROAD LIGHTS

Using these black vinyl covers for both 5" & 6" EmPI off-road lights helps you keep from breaking the glass lenses during your daytime fun runs. Choose from solid black vinyl, or EMPI "Eyes" and give your vehicle some serious attitude! All covers are sold in sets of 2, "Eyes" are sold as left & right = 1 pair.

- 16-9145 5" Light Covers, Plain, Pair
- 16-9146 5" Light Covers, "Eyes", Pair
- 16-9148 6" Light Covers, "Eyes", Pair



9497

## HEAVY DUTY OFF-ROAD TAIL LIGHTS

Great for all Sandrails, Buggies and Baja Bugs. Chromed heavy duty cast aluminum bodies for good looks and durability. Lights are 4 inch O.D. with a 1/2 inch bolt. Comes with dual filament 12-Volt Bulbs, 2 wires.

- 9497 H.D. Off-Road Tail Light w/Red Lens, Pair



16-9552

## L.E.D. OFF-ROAD TAIL LIGHTS

State of the Art L.E.D. circuitry. heavy duty chrome housing. Has both Tail and Stop light circuits. Lights are 4 inch O.D. with a 1/2 inch bolt, 3 wires.

- 16-9552 L.E.D. Off-Road Tail Light, Pair



9498

## OFF-ROAD TAIL LIGHT COVERS

Now you can even give your tail lights the "billet" look! Chrome steel bolt-on covers go right over the existing lense on our P/N: 9497 and 16-9552 tail lights and provide a great new look for a minimal amount of work.

- 9498 Off-Road Tail Light Covers, Pair

## 7" CHROME HEADLIGHT HOUSINGS

The original Dune Buggy Headlights are great for Buggies, Sandrails and Baja Bugs. Uses standard 7", 6 or 12-Volt sealed beam. (Bulbs not included). We now offer this housing with a 12-volt H4 55/60 watt bulb. Pigtail included. 3-Wire Hi / Low Beam. Wires: Green = Low Beam, Red = High Beam, Black = Ground.

- 9307-7                    7" Chrome Headlight Housing Only, Each (Boxed)
- 9305                    7" Chrome Headlight w/12-Volt H4 55/60W Bulb, Each (Boxed)
- 9311                    7" H4 Halogen Headlight Bulb Only, Round, Each (Boxed)
- 9304                    7" Sealed Beam Hi/Low Bulb Only, Each (Boxed)



## HEADLIGHT HOUSING

Designed for use with Baja Kits. Easy installation and adjustment. Features heavy duty plastic housing and chrome trim rings. Uses standard 7" 6 or 12-Volt sealed beam. Pigtail included. 3-Wire Hi / Low Beam. (Bulbs not included) Wires: Yellow = Low Beam, White = High Beam, Brown = Ground.

- 3019-7                    Headlight Housing w/ Chrome Ring, Each (Boxed)
- 16-3019                    Bulk Replacement Headlight Ring Only
- 9304                    7" Sealed Beam Hi/Low Bulb Only, Each (Boxed)
- 9311                    7" H4 Halogen Headlight Bulb Only, Round, Each (Boxed)



## H.D. HEADLIGHT WIRE PIGTAIL

Dim lights? Worn out wires or just old eyes, sometimes it's hard to tell. Start by replacing those existing headlight bulb pigtails with new ones and say good-bye to corrosion, erosion, etc. H.D. plastic plug with color coded 10ga. wires makes these about the best quality there is for this item and that should brighten up your day! 3-Wire Hi / Low Beam. Wires: Yellow = Low Beam, White = High Beam, Brown = Ground.

- 16-2102                    H.D. 3-Prong Headlight Pigtail / Connector



## BAJA LIGHT BAR

Steel tube light bar installs 4 lights on any Bug. Bolt-On installation - requires NO welding! Includes hardware.

- 9312                    Baja Light Bar, (Black Painted), Each



## MINI & MICRO MINI CHROME LIGHTS

These single and dual filament lights are ideal for clearance, parking, turn signal or tail lights. They feature diecast construction, and the prism lenses diffuse the light beam. Available with red or amber lenses. Comes with 12-Volt Bulbs.

### MINI LIGHTS, 2 1/2" X 1 3/4" X 2" (DUAL FILAMENT)



- 9334 Mini Light w/Red Lens, Each
- 9335 Mini Light w/Amber Lens, Each
- 9327 Replacement Dual Filament 12-Volt Bulb, 2 pcs.

### MINI LED TAIL LIGHT, 2 1/2" X 1 3/4" X 2"

Has a clear lens. Shows red stoplight and tail light, but goes amber in turn signal mode.



- 16-9836 Mini LED Tail Light Red/Red/Amber, Each

### MICRO MINI LIGHTS, 1 3/4" X 1" X 1 1/2" (SINGLE FILAMENT)



- 9330 Micro Mini Light w/Red Lens, Each
- 9331 Micro Mini Light w/Amber Lens, Each
- 9326 Replacement Single Filament 12-Volt Bulb, 2 pcs.

## TEARDROP TAIL LIGHTS

Add that Custom 50's Look to your Bug or Bus. Each assembly comes with a dual filament 12-Volt bulb. Requires cutting, fitting and wiring modifications.

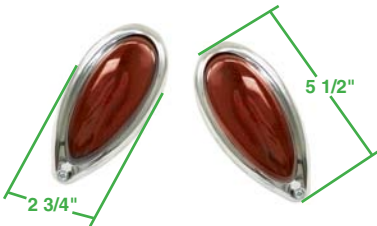

- 9490 Red Teardrop Tail Lights, Pair

## BLUE DOTS

The Ultimate 50's accessory! Fits all tail light lenses. Requires careful drilling of lens.



- 9491 Blue Dot w/Chrome Ring, Pair



**UNIVERSAL WIRE HARNESS W/FUSE BOX**

Complete wiring kit includes 6 Panel fuse box, fuses, wire, ends, fittings, electrical tape and instructions. Great for Buggies, Kit Cars and other special applications.

9466 Universal Wire Harness w/Fuse Box  
16-9466 6 Panel Fuse Box Only



16-9466



9466

**WEATHER-PROOF G.M. STYLE FUSE BOX**

Weather-Proof 10-position Fuse Box features G.M. Style Fuse receptacles, Spade Connectors. A sealed body and a clear top that also seals to the body with an O Ring. G.M. Style fuses are available in a number of amp sizes, easy to see if they are blown and are available practically everywhere. Update your Buggy or kit car with a modern fuse box.

9470 Weather-Proof G.M. Style Fuse Box



Style of Fuse

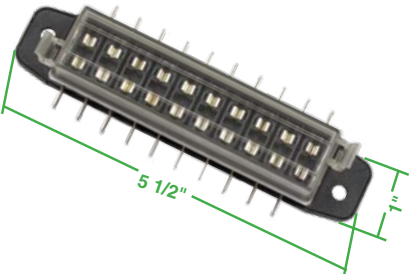

**REPLACEMENT HALOGEN BULBS - H1, H2 & H3**

EMPI offers a complete line of halogen headlight bulbs to fit most any application. Pick the style that fits your light and then choose the wattage best suited for your driving conditions. Be sure to check the vehicle's charging capacity to avoid overloading the system (watts ÷ volts = amps). [See page 349 for H4 Bulbs.](#)

16-9160 H1 12V 55W Bulb, Each  
16-9161 H1 12V 100W Bulb, Each  
16-9162 H1 12V 130W Bulb, Each

16-9163 H2 12V 55W Bulb, Each  
16-9164 H2 12V 100W Bulb, Each

16-9165 H3 12V 55W Bulb, Each  
16-9167 H3 12V 130W Bulb, Clear, Each



16-9160



16-9161

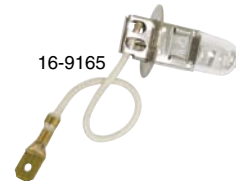

16-9165

**CHROME LICENSE PLATE LIGHT**

Chrome plated heavy gauge steel with built-in license light. Great for Baja Bugs and Buggies. Comes with 12-Volt Bulb. **(Note: When installed on Fiberglass be sure to ground to chassis)**

9457 Chrome License Plate Light w/Bracket



9457

**EMPI LICENSE PLATE FRAME**

License plate frame with EMPI logo.

6461 EMPI USA License Plate Frame, Front, Each  
6460 EMPI USA License Plate Frame, Rear, Each



6460



6461



## **BILLET ALUMINUM BUGGY DASH PANEL**

If you want a horizontal mounting dash panel instead of, or in addition to a center console, then this beauty is the one for you! Made from aluminum, it is CNC machined to exact tolerances including a 1 1/2" radius countersink so it nests onto the steering column cross tubes of most off-road cars. The front panel insert bolts in so it can be reversed if you want to change the gauge/switch position layout. A plain non-drilled insert is also available separately so you can do a custom layout of your choice.

- 16-3055**      Aluminum Dash Panel-2 gauge holes,  
6-switch/light holes
- 16-3056**      Insert Only, No Holes, for P/N: 16-3055 Dash Panel



## **POLISHED ALUMINUM BUGGY CENTER CONSOLES**

EMPI's universal Buggy Consoles are manufactured from heavy duty aluminum, precision welded and fully polished.

- 16-2052**      Center Console w/o Gauge Holes
- 16-3052**      High Rise Console w/o Gauge Holes
- 16-3053**      Aluminum Tall Center Console, No Holes

## **ALUMINUM SWITCH BOXES**

A great way to mount gauges, switches and warning lights in cars, trucks, buggies, carts or boats. Protects sensitive electronic gauges and switches from the elements. Rugged brushed aluminum construction and compact design makes them truly universal.

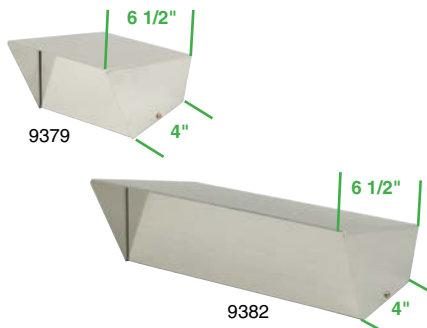

- 9379**      4" Box, w/o Holes  
4 1/4" x 3" Face I.D.
- 9382**      9" Box w/o Holes  
9 3/16" x 3" Face I.D.

\*See Electrical Pages 358 for Switches and Controls





## POLISHED STAINLESS STEEL GAS TANK KITS

Highly Polished Stainless Steel...Great looks and No Rust...ever! Stronger with a more durable finish - that won't dull - like polished Aluminum. Available in 5 lengths, 8" and 10" Diameter and include Polished Stainless Steel Straps (2), Stainless Steel Hardware and a Black Plastic Gas Cap. Gallons are estimated. **(Off-Road Use Only)**



### STAINLESS STEEL GAS TANKS 10" DIAMETER

- 3895 S/S Gas Tank, 10" X 16", Center Fill, 5 Gallon
- 3896 S/S Gas Tank, 10" X 24", End Fill, 7.7 Gallon
- 3885 **NEW!** S/S Gas Tank, 10" X 24", Center Fill, 7.7 Gallon
- 3897 S/S Gas Tank, 10" X 30", End Fill, 9.5 Gallon
- 3886 **NEW!** S/S Gas Tank, 10" X 30", Center Fill, 9.5 Gallon
- 3898 S/S Gas Tank, 10" X 33", End Fill, 10.7 Gallon
- 3887 **NEW!** S/S Gas Tank, 10" X 33", Center Fill, 10.7 Gallon
- 3899 S/S Gas Tank, 10" X 40", End Fill, 13 Gallon
- 3888 **NEW!** S/S Gas Tank, 10" X 40", Center Fill, 13 Gallon

## 10" Diameter



### STAINLESS STEEL GAS TANKS 8" DIAMETER

- 3789 **NEW!** S/S Gas Tank, 8" X 16", Center Fill, 3.1 Gallon
- 3796 **NEW!** S/S Gas Tank, 8" X 24", End Fill, 5 Gallon
- 3795 **NEW!** S/S Gas Tank, 8" X 24", Center Fill, 5 Gallon
- 3798 **NEW!** S/S Gas Tank, 8" X 30", End Fill, 6.1 Gallon
- 3797 **NEW!** S/S Gas Tank, 8" X 30", Center Fill, 6.1 Gallon
- 3800 **NEW!** S/S Gas Tank, 8" X 33", End Fill, 6.8 Gallon
- 3799 **NEW!** S/S Gas Tank, 8" X 33", Center Fill, 6.8 Gallon

## 8" Diameter



Center Fill / 3885 **NEW!**



End Fill / 3896



Center Fill / 3895



End Fill / 3897



When installing a fitting or shut-off valve, caution must be taken not to over-torque and crack or break the fuel outlet.



17-2761



17-2760

### GAS CAPS

17-2760  
17-2761

Replacement Black Plastic Gas Cap, Each  
Billet Aluminum Gas Cap for S/S Tanks, Each



## STAINLESS STEEL FUEL TANK BRACKETS

- 17-2929** Replacement Polished [Stainless Steel](#) 10" Dia. Fuel Tank Bracket w/ S/S Hardware, 3/4" Wide, Each
- 17-2936** **NEW!** Replacement Polished [Stainless Steel](#) 8" Dia. Fuel Tank Bracket w/ S/S Hardware, 3/4" Wide, Each

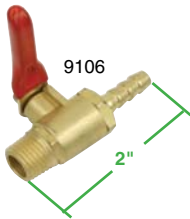

## FUEL SHUT-OFF VALVE

Fits both stainless steel and aluminum gas tanks.

- 9106** Fuel Shut-Off Valve, 1/4" Hose x 1/4" NPT



## FLIP-TOP FUEL FILLER CAP

This polished aluminum Fuel Filler Cap features a spring action top with a spring-loaded latch. Quick action for fast fueling...and never worry about losing your gas cap. Perfect for buggies or bajas, it is vented and features a convenient mounting flange. Fits any 2" opening.

- 16-6033** Flip Top Fuel Filler Cap



## FUEL TANK FILLER BUNG AND CAP

Aluminum bung, cap, and o-ring for custom fuel tanks.

- 17-2529** Bung, Fuel Tank, 3 pc. Set



## REMOTE FILLER NECK AND CAP

This aluminum filler neck and cap are supplied with a weld-on bracket. Great for mounting the filler cap outside of the vehicle and running a hose to your fuel tank or fuel cell. Two inch filler hose required.

- 17-2530** Remote Filler Neck, 3 pc. Set



## BILLET ALUMINUM TANK GAS CAP ACCESSORIES

Billet aluminum gas cap is made from fully polished 6061 T-6 aluminum.

- 16-3538** [Billet Gas Cap](#), All [Aluminum Tanks](#)

## REPLACEMENT PARTS & ACCESSORIES

- 3536** Replacement Mounting Bracket, 8" Dia., Black Mount Holes 4" Apart, 3/4" Wide, Each
- 3537** Replacement Mounting Bracket, 10" Dia., Black Mount Holes 5" Apart, 3/4" Wide, Each
- 3538** Replacement Gas Cap, All [Aluminum Tanks](#)



## BILLET LIGHT POLE MOUNTS

No more welding or drilling to mount your whip light pole, just clamp on one of these great Aluminum Billet Mounts and you are off to the races. Better yet, the Lay Down Mount with stainless steel "Pit-Pin" allows you to fold down the pole without removal. (Use with P/N: 16-1010 Base Mount)

- 16-7501 Billet Aluminum Fold Down Pole Mount for 1 1/2" Tubing
- 16-9571 Billet Aluminum Fold Down Pole Mount for 1 3/4" Tubing
- 16-7500 Billet Aluminum Pole Mount for 1 1/2" Tubing



## BAJA & BUGGY LIGHT POLES

Make sure they see you coming before you crest that dune! Kit includes strong fiberglass pole, built-in mount, safety flag and hardware. Add a Light, either Standard Bulb, Super Brite L.E.D. or Flashing L.E.D., to either pole by using P/N: 16-1010...even personalize with your choice of color with our optional lamp shields. Battery pack can also be used to make the L.E.D. lights operational.

- 16-1001 Buggy Light Pole, w/Flag, 5'
- 16-1002 Buggy Light Pole, w/Flag, 8'
- 16-1010 Base Mount for Light Pole
- 16-1009 Standard Bulb for Light Pole
- 16-1013 Chrome Cap for Lamp Shield
- 16-1004 Lamp Shield, Red, Each
- 16-1005 Lamp Shield, Amber/Yellow, Each
- 16-1007 Lamp Shield, Blue, Each
- 16-1008 Lamp Shield, Clear, Each
- 16-9505 Battery Pack, w/o Batteries (Requires 3 batteries)
- 16-9506 Battery Only for Pack, Each
- 16-9523 Billet Slide Over Cover for Mount 16-1010

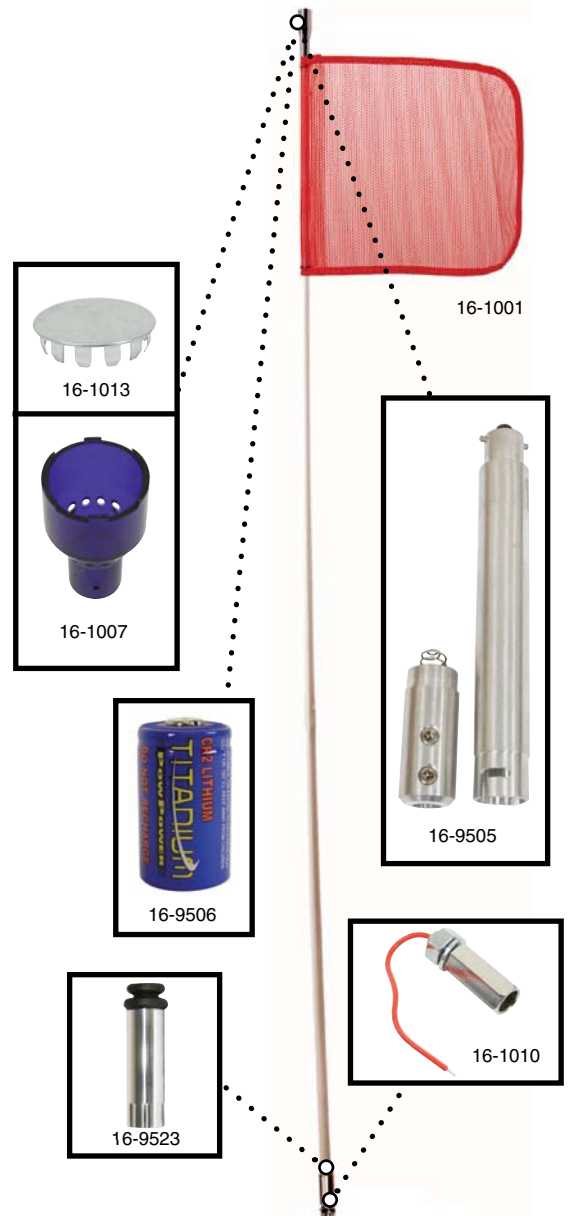

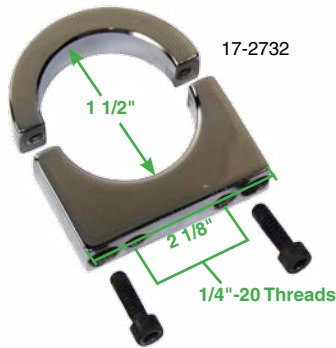

## **BILLET BRACKET, NARROW**

Fits 1 1/2" tube, 2 1/8" wide.

17-2732 Billet Bracket, Narrow, Each



## **SHAPED BILLET BRACKET**

Shaped with a single post. Use to mount mirrors, lights, etc. Available for 1 1/2" and 1 3/4" tubing.

17-2730 Shaped Bracket, Billet, 1 1/2", 3/8-16 Threads, Each  
 17-2882 Shaped Bracket, Billet, 1 1/2", 8mm x 1.25 Threads, Each  
 17-2731 Shaped Bracket, Billet, 1 3/4", 3/8-16 Threads Each



## **BILLET LIGHT MOUNT BRACKET**

Designed with the billet "bullet" style headlights in mind. Right and Left hand brackets for 1 1/2" tubing.

17-2742 Light Mount Bracket, Billet, Pair

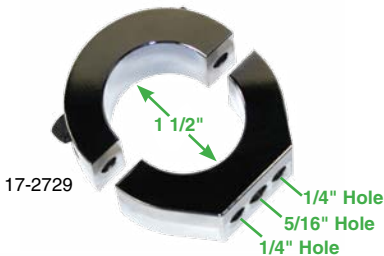

## **BILLET BRACKET, EXTRA WIDE**

A 1" wide single hole bracket. Fits 1 1/2" tubing. Great for a tachometer mount.

17-2729 Billet Bracket, Extra Wide, Each



## **BILLET SHOCK RESERVOIR CLAMPS**

Available for 2.0" and 2.5" reservoirs. Fits 1 1/2" tubing.

17-2710 Reservoir Clamp, Billet, 2.0", Each  
 17-2711 Reservoir Clamp, Billet, 2.5", Each





## BILLET ALUMINUM BRAKE LINE BRACKET

EMPI's billet aluminum brake line brackets provide the high tech solution to brake line mounting. Split clamping design allows for quick, easy placement plus the ability to relocate without leaving a mounting hole. Fits 3/16" brake line.

- 17-2831 Polished Aluminum Brake Line Bracket, 3/4"
- 17-2832 Polished Aluminum Brake Line Bracket, 1"
- 16-9569 Polished Aluminum Brake Line Bracket, 1 1/2"

- 16-7021 Polished Aluminum Brake Line Bracket, 1 1/4" Front Brake Line, Long-Travel A-Arm Suspension
- 17-2830 Billet Brake Line Bracket, Swing Axle Rear Brake Line - Clamps to Swing Arm



## BILLET ALUM. UNIV. TACH MOUNT BRACKET

EMPI's Billet Aluminum Bracket makes mounting your monster style tach quick and easy. Polished mount clamps onto 1 1/2" tubing and has 1" wide pivoting mount block for the tach band to bolt to. Check your tach mounting point for width. Spacers and longer bolts may be required.

- 16-7023 Polished Alum. Univ. Tach Mount Bracket for 1 1/2" tubing



## SIDE DRILLED BILLET BRACKETS 3 1/2" WIDE

Available for 1 1/2" and 1 3/4" tubing.

- 17-2737 Side Drilled Bracket, Billet, 1 1/2", Each
- 17-2738 Side Drilled Bracket, Billet, 1 3/4", Each

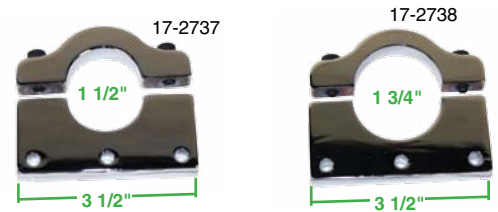

## SIDE DRILLED BILLET BRACKETS 2 3/4" WIDE

Available for 1 3/4" tubing.

- 17-2736 Side Drilled Bracket, Billet, 1 3/4", Each

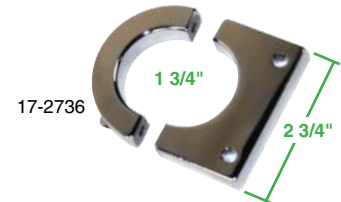

## BILLET FOOT REST

Fits 1" tubing. The foot pad position is adjustable.

- 17-2741 Foot Rest, Billet, Each



## BILLET BRACKET, UNDRILLED

Available for 1 1/2" and 1 3/4" tubing. The 1 1/2" bracket is a thru-bolt design and the 1 3/4" bracket has threaded bolts and is 3 3/4" wide.

- 17-2733 Billet Bracket, Undrilled, 1 1/2", Each
- 17-2734 Billet Bracket, Undrilled, 1 3/4", Each

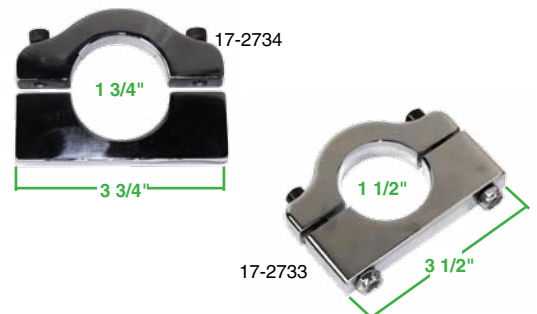

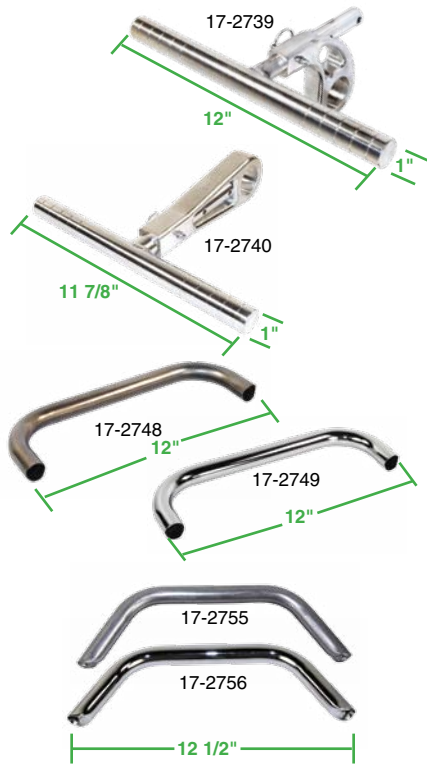

## BILLET GRAB HANDLES

Clamp on billet grab handles. Available in 2 styles: straight and angled. Fits 1 1/2" tubing.

- 17-2739 Billet Grab Handle, Angled, Each
- 17-2740 Billet Grab Handle, Straight, Each

## 90 DEGREE GRAB HANDLES / FOOT REST

Weld-in, pre-bent grab handles are radiused on the ends for a clean fit. Available raw or chrome.

- 17-2748 90 Degree Grab Handle, Raw, Each
- 17-2749 90 Degree Grab Handle, Chrome, Each

## 45 DEGREE GRAB HANDLE / FOOT REST

A slightly different look. These weld-in tubes are bent at a 45 degree angle. The ends are radiused for a clean fit. Available raw or chrome.

- 17-2755 45 Degree Grab Handle, Raw, Each
- 17-2756 45 Degree Grab Handle, Chrome, Each

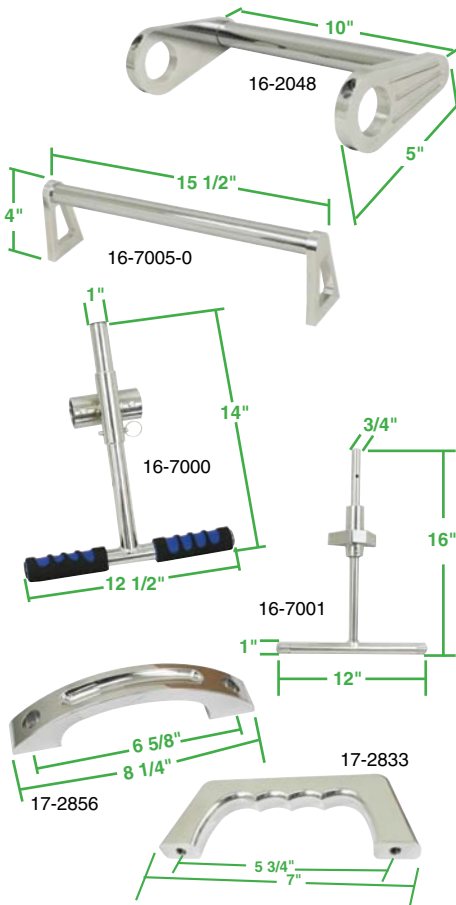

## BILLET ALUMINUM BUGGY GRAB BAR & FOOT REST

Hold on tight and keep your feet firmly planted with our Billet Aluminum Grab Bar and Foot Rest.

- 16-2048 Billet Grab Bar, For 1 1/2" Tubing
- 16-7005 Billet Foot Rest, Direct Mount

## ADJUSTABLE GRAB HANDLES

Something to hold on to. Give your riders the extra safety of a firm handhold. Both have a telescoping length adjustment to suit tall or short passengers and soft rubber grips (P/N: 16-7000) for a secure hold. Choose from the heavy walled steel tube type with dual half cap clamp design that is chrome plated or the fully polished Billet Aluminum Adjustable type with radius mount and sleeved housing. Both are designed to fit 1 1/2" frame tubing.

- 16-7000 Adjustable Steel/Chrome Grab Handle
- 16-7001 Adjustable Billet Aluminum Grab Handle

## BILLET GRAB HANDLE

Get a Grip! Bolt-on billet grab handles with grip or smooth design.

- 17-2833 Billet Grab Handle, 5/16" Hole, Each
- 17-2856 Billet Grab Handle, 5/16" x 18, Each



## BILLET MOUNTS AND BRACKETS

Combine function and beauty with these custom machined and fully polished aluminum Billet mounts and brackets. All 4 universal mounts have the same 1/4"-20 x 1" mounting screw spacing to make them interchangeable for various accessories.

- 16-7007 Billet Universal Mount for 1" Tubing
- 16-7008 Billet Universal Mount for 1 1/4" Tubing
- 16-7009 Billet Universal Mount for 1 1/2" Tubing
- 16-9570 Billet Universal Mount for 1 3/4" Tubing

- 
- 16-7015 Billet Coil Clamp Only  
*Shown with Coil Installed*

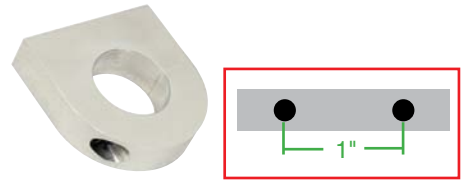

16-7007



16-7015

## BILLET GPS MOUNT

Welcome to the 21st century, it's time you take that little bobbing dash compass and throw it as far as you can. GPS is here and can be a real lifesaver when exploring unknown territory. EMPI's polished aluminum GPS mount securely holds your hand held unit in clear view for quick reference. Features polished aluminum construction with adjustable thumb screws to fit most hand held GPS units.

- 
- 16-7011 Polished Aluminum Billet GPS Mount for 1 1/2" Tubing

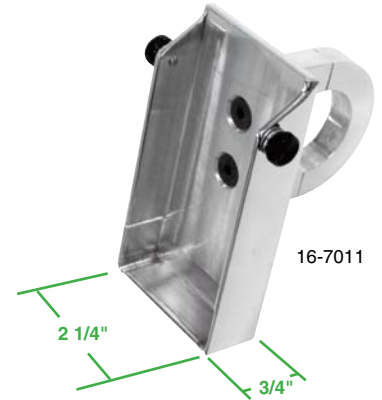

16-7011

## BILLET OFF-ROAD REGISTRATION STICKER BRACKET

Many states require the registration of off-road vehicles and issue a sticker that must be displayed on the vehicle. EMPI's polished aluminum sticker bracket provides a clean conspicuous way to display your sticker. 4 1/4" x 2 3/4" plate accommodates most stickers. Use any universal mount from above to accommodate mounting for your application.

- 
- 16-7020 Off-Road Registration Sticker Bracket



16-7020

## EMPI BILLET ALUMINUM STEP

As featured on EMPI's own "Sand Pincher" Sand Rail, these Polished Billet Steps add flare to your tall, long travel sand rail foot pegs. 3/8" x 24 threaded hole.

- 
- 16-9560 EMPI Billet Aluminum Step, Pr.

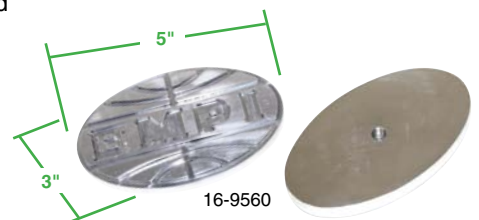

16-9560

## BILLET FOOT PEGS

Bolt-on billet foot pegs. Knurled design, tapped for 1/2" x 20 mounting.

17-2834

Billet Foot Pegs, Pair

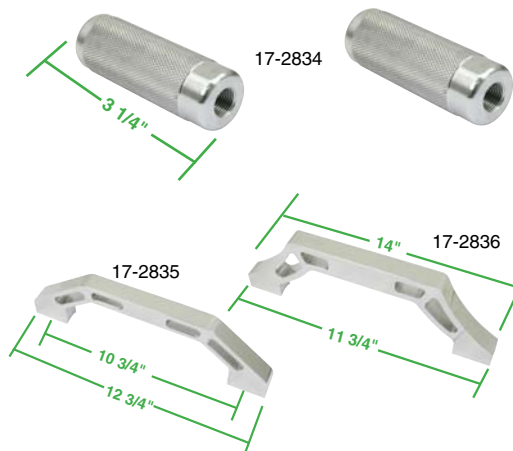

## BILLET SIDE STEPS

Bolt-on billet side steps in two cool styles.

17-2835

Billet Side Step, Short, 1/2 x 13 Coarse, Each

17-2836

Billet Side Step, Long, 1/2 x 13 Coarse, Each

## BILLET HEADSET HANGERS

Bolt-on a billet place to hang your headsets when not in use.

17-2837

Billet Headset Hanger, 1 1/2", Each



## BILLET DELUXE WHIP ANTENNA MOUNTS

Bolt-on billet deluxe whip antenna mount, adjustable for sweep angle.

17-2839

Deluxe Billet Whip Antenna Mount, 1 1/2", Each

17-2840

Deluxe Billet Whip Antenna Mount, 1 3/4", Each

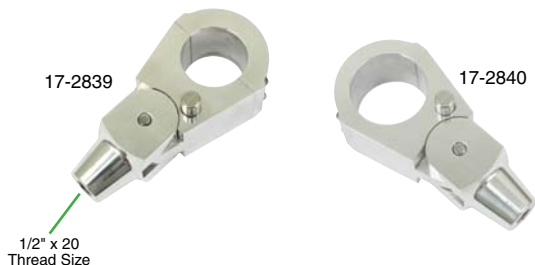

## BILLET 'J-HOOK' SUPPORT BRACKETS

Hooks around your frame - then easily bolt your solid or mesh floor panels to the J-Hooks. No welding tabs. Simple - and great looking. 5/16" x 18 threads.

17-2915

Billet Support Bracket, 1 1/2", Set of 5

17-2916

Billet Support Bracket, 1 3/4", Set of 5



## BILLET UNIVERSAL SUPPORT BRACKETS

Bolt-On most any accessory - GPS, Coil...anything that you can bolt-on to the flat Billet Bracket. Available for mounting on 3 tube sizes.

17-2912

Universal Billet Support Bracket, 1", Each  
Length = 4 7/16", Height = 2 3/8", Width = 2 1/2"

17-2913

Universal Billet Support Bracket, 1 1/4", Each  
Length = 4 7/16", Height = 2 3/8", Width = 2 1/2"

17-2914

Universal Billet Support Bracket, 1 1/2", Each  
Length = 4 7/16", Height = 3", Width = 2 1/2"

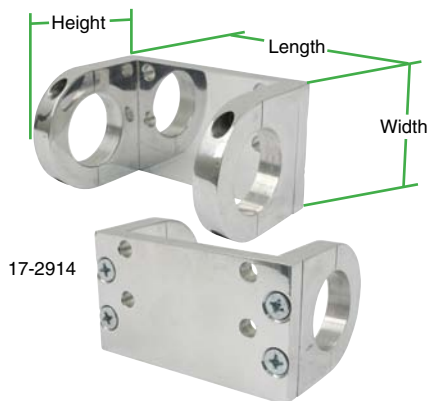





**EMPI BILLET BREATHER**

Function and form. Finish off your sand rail with these Polished Billet Breather Tubes. Available with colored EMPI covers or with chrome shielded covers.

- 16-2049 Billet Breather Tube w/Blue Filter Covers
- 16-2050 Billet Breather Tube w/Red Filter Covers
- 16-5153 Billet Breather Tube w/Shielded Filter Covers

- 16-5151 Replacement Filter w/Shielded Cover for P/N: 16-5153, Each
- 16-5152 Replacement Filter for P/N: 16-2049 & 16-2050, Each

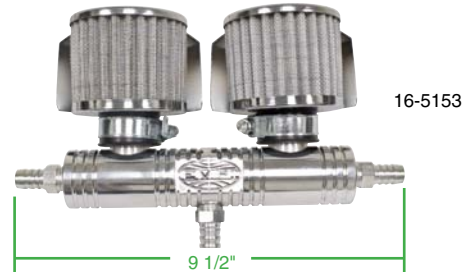

**BILLET VERTICAL BREATHER**

EMPI's Billet polished canister type breather box features high quality all aluminum construction with removable lid for easy servicing of the foam element, provisions for up to four breather lines and a split type mounting clamp that makes installation as easy as tightening two screws. Washable foam insert separates oil from vapors while keeping out dust and dirt. Vapors are released from vents under the cap. (See page 423 for mounting clamps in additional sizes)

- 16-7030 Polished Alum. Vented Breather Box, 1 1/2" Tube Mount



**CRANK CASE BREATHER**

Gauze element breather with chrome top and bottom plates and 1/2" centered hole. Available shielded and unshielded. Also offset hole version for extra clearance.

- 9052 Gauze Breather Filter, Shielded (1/2" centered hole)
- 9053 Gauze Oil Filler Breather, (1/2" offset hole) Hole location is very close to the edge.





8544

## **EMPI CAST ALUMINUM OIL BREATHER KIT**

Reduce crankcase pressure, eliminate blow-by and oil loss. High revving modified engines require more crankcase ventilation than the stock breather can supply. With the EMPI Aluminum Oil Breather Kit the blow-by oil is collected in the foam filter and the air vapors are vented to the atmosphere. New features include the EMPI logo cast in the top, improved heavy duty breather hose, plus internal changes that includes a screen mesh shelf to elevate the foam filter element.

- 8544** Complete Engine Oil Breather Kit
- 9242** Replacement Hose, Black (8 Feet)



17-2941

## **EMPI OIL FILLER & BREATHER BOX**

The EMPI dual-purpose Oil Filler & Breather Box includes a system of internal baffles that separate the oil from the air then returns the oil back to the engine. It mounts upright on the alternator stand making for easy oil filling and was designed to look like part of the engine. The Billet Aluminum filler cap seals with an O'ring. Aluminum construction offers great looks and leak-free operation featuring an O'ring seal and Button-head Allen top screws. Vent your valve covers, crankcase, air cleaners...whatever your requirements. Comes with attaching nut, O'rings, gasket and instructions. There are 4 threaded ports and all are 1/4" NPT.

- 17-2941** Oil Filler & Breather Box Kit



8540

## **OFF-ROAD BREATHER**

Designed for maximum breathing filtration. The chrome steel tower design returns the blow-by oil to the engine while the high capacity gauze filter with spun aluminum top cover keeps dirt out during deceleration.

- 8540** Off-Road Breather Kit
- 8541** Replacement Gauze Element, Each



16-8240

16-8241

## **BILLET UNIVERSAL OIL FILTER MOUNT**

EMPI's Bolt-On Full Flow Oil Filter Mounts make filter mounting easy. Inward and outward polished aluminum exhaust flange mounts accommodate most off-road and drag race applications.

- 16-8240** Billet Inward Facing Exhaust Flange Oil Filter Mount
- 16-8241** Billet Outward Facing Exhaust Flange Oil Filter Mount





## STAINLESS STEEL RADIATOR OVERFLOW TANKS

A compact design constructed of polished stainless steel. 13 3/4" overall length and 2" diameter. Available with or without welded mount tabs.

- 17-2534 Overflow Tank, **Stainless Steel**, with Bracket, Each (Boxed)
- 17-2535 Overflow Tank, **Stainless Steel**, w/o Bracket, Each (Boxed)



## ALUMINUM AIR FILTERS

This design is used by almost every off road race car racing today. Available with 4" inlets and 4" outlets in either 12" or 15" length housings. This aluminum air filter uses a 2 phase inner filtering system. Choose from right or left side in the 4" X 4" models in both 12" and 15" bodies.

- 17-2516 Air Filter, Polished **Aluminum**, 12" Body, 4" Inlet, 4" Outlet Left Side, Each (Boxed)
- 17-2517 Air Filter, Polished **Aluminum**, 12" Body, 4" Inlet, 4" Outlet Right Side, Each (Boxed)
- 17-2519 Air Filter, Polished **Aluminum**, 15" Body, 4" Inlet, 4" Outlet Left Side, Each (Boxed)
- 17-2520 Air Filter, Polished **Aluminum**, 15" Body, 4" Inlet, 4" Outlet Right Side, Each (Boxed)

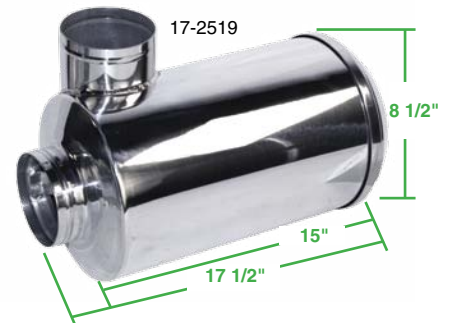

## SLOTTED AIR FILTER

The same concept as our other Air Filters, but with a slotted non-directional inlet. Available in 12" and 15" bodies. 4" outlet only. **Supplied without filter element.**

- 17-2521 Slotted Air Filter, Polished **Aluminum**, 12" Body Each (Boxed)
- 17-2522 Slotted Air Filter, Polished **Aluminum**, 15" Body Each (Boxed)

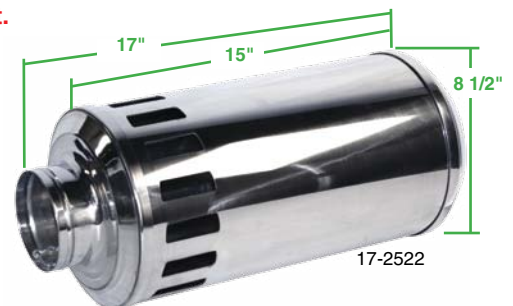



17-2689

## AXLE STRAPS

Save your paint. Loop these straps around your chassis or trailing arms and hook your tie down to these. Sold in pairs.

**17-2689** Axle Strap, 2" Wide x 24" Long, Pair

**17-2969** Axle Strap, 2" Wide x 16" Long, Pair



17-2690

## TOW STRAPS

Sold with hooks on each end or with loops on each end. Available in 1 1/2" widths rated at 3300 lbs., 2" width rated at 8,000 lbs, 2 1/2" widths rated at 5500 lbs., and 3 1/2" widths rated at 10,000 lbs. Always use caution when using tow straps.

**3849** Tow Strap with Hooks, 2" x 15', 8,000 lbs, Yellow, Boxed, Each

**17-2690** Tow Strap with Hooks, 1 1/2" x 13', 3300 lbs, Black, Each

**17-2691** Tow Strap with Hooks, 2 1/2" x 13', 5500 lbs, Black, Each

**17-2692** Tow Strap with Hooks, 3 1/2" x 13', 10,000 lbs, Black, Each

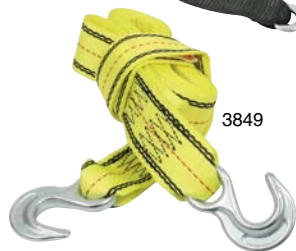

3849



17-2693

**17-2693** Tow Strap with Loops, 1 1/2" x 13', 3300 lbs, Black, Each

**17-2694** Tow Strap with Loops, 2 1/2" x 13', 5500 lbs, Black, Each

**17-2695** Tow Strap with Loops, 3 1/2" x 17', 10,000 lbs, Black, Each



17-2860

## TIE DOWNS - CAMLOCK STYLE

Quickly and easily secure your gear, ATV or pit bike with these 1" wide tie downs. Vinyl coating protects from scratches and spring-loaded hook quickly and securely attaches to truck or trailer. Pull to tighten. Release by depressing cam lock lever. Vinyl hook can also hook into sewn-in strap to create a soft-tie axle strap.

**17-2860** Tie Downs, 1" Camlock, 5' Long, Each



17-2861

17-2862

## RATCHET TIE DOWNS

Easily ratchet-down to secure your gear, ATV or pit bike with these 1" wide tie downs. Vinyl coating protects from scratches and spring-loaded hook quickly and securely attaches to truck or trailer. Ratchet to tighten, pull release bar to loosen. Locks when ratchet is closed. 2" model features vinyl grips. Attach end clips to sewn-in hook to create built-in axle strap.

**17-2861** Tie Downs, 1" Ratchet, 5' Long, Each

**17-2862** Tie Downs, 2" Ratchet, 5' 5" Long, Each



# TOOLS & TOW BARS

## TOW BARS

All heavy duty steel construction, easy to install and available with 2" ball receiver. Includes pins & clips. The Super Beetle Tow Bar includes mounting plate. Narrowed Tow Bar fits 2" Narrow Beams. Never back up when using a tow bar.

- 3127 Tow Bar, Sedan/Buggy, 2" Ball
- 3128 Tow Bar, Sedan/Buggy, w/ 2" Narrow Beam, 2" Ball

- 3131 Tow Bar, Super Beetle, 2" Ball, w/Mounting Plate
- 3131-7 Tow Bar Only, Super Beetle, 2"
- 3190 Mounting Plate Only, for P/N: 3131

- 3137 Replacement Pins & Clips, Long, for P/N: 3127, Pair
- 3138 Replacement Pins & Clips, Short, for P/N: 3131, 3131-7, Pair

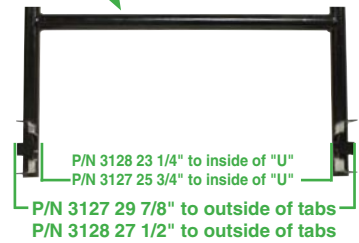

Center to Center of the tabs



## UNIVERSAL TOW BAR

Easy to adapt to most cars. Complete with mounting plate and hardware. May require drilling and fitting. Never back up when using a tow bar. (Intended for light duty use only).

- 3133 Universal Tow Bar 2", w/Mounting Plate
- 3131-7 Tow Bar Only, 2"
- 3192 Mounting Plate Only, for P/N: 3133



## EMPI SPARE TIRE TOOL BOX

EMPI brings back another old favorite with our reproduction of the ever popular and useful spare tire tool box. The EMPI globe logo embossed lid folds down to reveal a true to original assortment of tools to help with roadside repairs. Fits all stock and chrome rims that utilize hub cap clips. Supplied with tools. Tools supplied should be considered for show only and not for actual use.



15-2016 EMPI Spare Tire Tool Box



5002

## **OIL PUMP PULLER**

Protects pump from damage and is easy to use. For 6 or 8mm pump bodies.

5002 Oil Pump Puller

---



5003

## **UNIVERSAL FLYWHEEL LOCK**

Can be used on 6 or 12-Volt flywheels.

5003 Universal Flywheel Lock

---



5763

## **VALVE GUIDE INSTALLER**

5763 Valve Guide Installer

---



5750

## **AXLE & GLAND NUT REMOVAL TOOL**

Dubbed the "Helping Hand" tool, helps loosen stubborn hi-torqued axle and gland nuts by holding the drum or flywheel steady.

5750 Axle & Gland Nut Removal Tool

---



5004

## **FLYWHEEL DOWEL PIN FIXTURE**

Provides perfect positioning for drilling extra dowel pin holes in crank & flywheel for 8-dowel pin installation.

5004 Dowel Pin Fixture

---



5714

## **CRANKSHAFT GEAR PULLER**

Easily and correctly removes VW and Porsche crank timing gear. Also removes 3rd and 4th transmission gear set.

5714 Crankshaft Gear Puller

---



5717

## **DISTRIBUTOR DRIVE PULLER**

Easily removes distributor drive gear.

5717 Distributor Drive Puller

---



## VW CLUTCH PILOT TOOLS

Made from high impact, wear and abrasion resistant plastic. Aligns clutch disc with pilot bearing. Comes on attractive EMPI Display Card. [See page 458 for complete detailed specifications and listings.](#)

5302-K	Type 1, Ghia & Thing, 49-79
5367-K	Type 1, Ghia Autostick, 68-74
5302-K	Type 2, 50-71, 1200-1600
5335-K	Type 2, 72-79, 1700-2000
5302-K	Type 3, 63-73, 1500-1600
5335-K	Type 4, 411-412, 71-74, 1700-1800
5335-K	Vanagon, Gas, 80-92
5302-K	Vanagon, Diesel, 82-84
5311-K	33 Spline, G50
5302-K	Dasher, 75-81
5302-K	Fox, 87-93
5378-K	Rab/Scir, Golf, Jetta, 74-97 (Exc. 16V)
5378-K	Cabriolet, Cabrio, 85-98
5378-K	Quantum, Gas, 82-85
5335-K	Quantum, Diesel, 83-85
5403-K	All 16 Valve VW
5415-K	Corrado, Passat, 89-95
5403-K	Beetle (New), Gas, 98-99



## BENCH ENGINE STAND

Mounts to work bench. Features swivel head. Use for holding engines or transmissions. 1 5/8" male tube that slides into mount.

5001	Bench Engine Stand
------	--------------------



## H.D. ENGINE STAND

Holds engine or transmission. Features swivel head, H.D. steel construction with metal casters for mobility. Knock-down style allows for UPS shipments.

5007	H.D. Engine Stand, Knock-down
------	-------------------------------



## PROFESSIONAL VW ENGINE STAND

For the Pro Engine Builder, or for safely displaying engines in your showroom. This Pro VW Engine Stand features 2 long, diagonal forward legs for stability and strength. Urethane-clad Wheels each with brake and a 4-arm, gusseted Head to firmly hold the engine case. Painted brilliant Red for durability and good looks. Built to work hard, last long and look good! Unit is supplied knock-down in a box.

5015	Professional VW Engine Stand
------	------------------------------





## **HEAVY DUTY ENGINE FLOOR DOLLY**

EMPI's Heavy Duty Engine Floor Dolly features heavy gauge steel for strength and 4 industrial swivel caster wheels for stability. Use for all VW Air Cooled Engines. Outside dimensions are 11.5" wide by 12.75" long by 6.5" high.

5005 Heavy Duty Engine Floor Dolly

---



## **UNIVERSAL VALVE ADJUSTMENT TOOL**

Allows for easier valve adjustment.

5888 Valve Adjustment Tool, 13mm

---



## **PISTON RING COMPRESSOR**

Compress piston rings for easy piston installation. Use with common pliers.

5764 Ring Compressor, 83-87mm  
5765 Ring Compressor, 88-94mm

---



## **FLYWHEEL SEAL INSTALLATION TOOL**

Easily installs rear main seal using stock gland nut.

5775 Flywheel Seal Installation Tool

---



## **DELUXE FLYWHEEL SEAL INSTALLATION TOOL**

Installs rear main seal without removing dowel pins.

5774 Deluxe Flywheel Seal Installation Tool

---



## **CRANK PULLEY PULLING AID TOOL**

Helps to remove crankshaft pulley.

5784 Crank Pulley Aid

---



## **VW CLUTCH ADJUSTING WRENCH**

Makes clutch adjustment a cinch.

5810 Clutch Adjustment Tool, Air-cooled





# TOOLS & TOW BARS

## SCISSOR JACK

Originally made for Type 2's, but will work on Sedans, & Ghias offering extra jacking height. Great for use on lowered cars.

98-0109-B Scissor Jack Type 2 & Type 1, Each  
(Ref P/N: 237 011 031)



## PUSH ROD MEASURING TOOL

Adjust out, lock down, measure, and cut push rods.

16-9600 Push Rod Measuring Tool, Each



## BENCH MOUNT HEAD ASSEMBLY TOOL

Bench model for easy removal of valve springs.

5742 Bench Mount Head Assembly Tool, Boxed



## CONDENSER INSTALLATION TOOL

Eliminate broken wires and plugs while reducing installation time when installing the condenser in a press-in type distributor. Tool provides clearance for the wires while making square contact with the plug.

5772 Condenser Installation Tool



## TRANSAXLE DRAIN PLUG TOOLS

5773 Trans Drain Plug Tool, 17mm, 3/8" Drive  
5788 Trans Drain Plug Wrench, 17mm

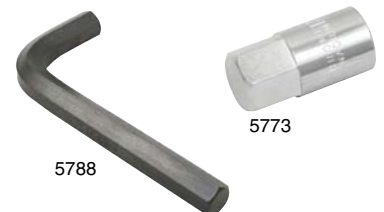

## C.V. JOINT BOLT SOCKET

Available for 6-Point and 12-Point 8mm Hex C.V. joint bolts.

5796 C.V. Joint 12-Point Hex Socket, 8mm, 3/8" Drive  
5797 C.V. Joint 6-Point Hex Socket, 8mm, 3/8" Drive



## TOOL CARRIERS

An attractive and compact method of carrying your emergency tools in your off road vehicle, street rod, or boat. Made from 3 1/2" polished aluminum tube, the lid snaps into place and is secured with a screw-in knob. This is a bolt on application.

17-2746 Tool Carrier, Bolt on, Each (Boxed)

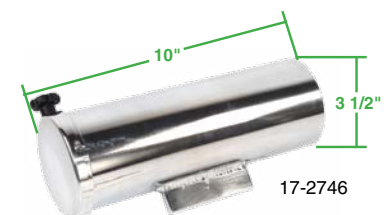



## GLAND / AXLE NUT SOCKETS

Remove gland or axle nuts with this socket and your breaker bar.

- 5770** Gland/Axle Nut Socket, 36mm, 1/2" Drive  
**5769** Axle Nut Socket, 46mm, 3/4" Drive



## AXLE NUT TOOLS

Remove rear axle nuts with this tool and your 1/2" breaker bar.

- 5748** Axle Nut Removal Tool, 36mm  
 For all Type 1, 3 & 4 and Type 2, 62 & Prior  
**5749** Axle Nut Removal Tool, 46mm  
 For Type 2, 63 & Later



## DECK HEIGHT MEASURING TOOL

Accurately check critical deck height for appropriate valve clearance and compression.

- 5756** Deck Height Measuring Tool

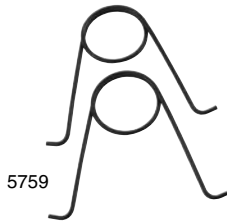

## VALVE LIFTER RETAINING CLIPS

Holds lifters in place during engine assembly.

- 5759** Valve Lifter Retaining Clips, Pair



## END-PLAY MEASURING TOOL

Accurately measure crankshaft end play.

- 5760** End-Play Measuring Tool



## OIL FILLER NUT TOOLS

Easily install or remove oil filler. For the really tough to remove nut, use the internal nut removal tool.

- 5761** Oil Filler Nut Removal Tool, 1/2" Drive  
**5102** Oil Filler Nut Removal Tool w/Internal grip



## VW & AUDI TENSION SPANNER

For adjusting camshaft belt tension.

- 5811** VW/Audi Tension Spanner



# TOOLS & TOW BARS

## TORQUE MULTIPLIER

Helps multiply torque when tightening gland nuts and axle nuts.  
 Fits 12v and 6v flywheel, and 4x130 and 5x205 wheels.  
 24 FT. LBS = 216 (Rear Axle Nut)  
 30 FT. LBS = 270 (Gland Nut)

16-9602 Torque Multiplier, Kit



## CASE SPLITTER

Insert in the oil pump hole and expand the case halves.

16-9601 Case Splitter, Kit



## HEAD CC MEASURING KIT

Comes with discs for 85.5, 90.5 / 92 and 94mm Cylinders.

16-9603 Head CC Measuring Kit

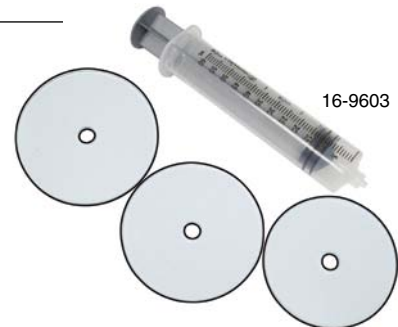

## GASGACINCH GASKET SEALER

The best for sealing engine cases and gaskets.

**Sold in case quantity only. (If you order Quantity 1, you will get a case of 24 cans) 1 = 24.**

5124 GASGACINCH, 4 oz. Cans, 24 Per Case  
**(CANNOT be shipped via AIR)**



## MOLY ASSEMBLY LUBE

Applied to all bearing surfaces, cam and cam followers during assembly, this high grade moly lube insures proper lubrication upon initial engine start up and run in.

27-0160 **NEW!** Moly Assembly Lube, 1/4 oz. Tube

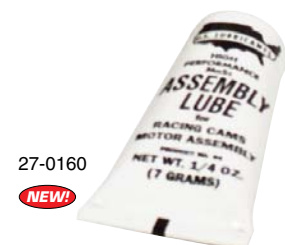



## **CARBURETOR SYNCHRONIZERS**

Proper synchronization of dual carburetor set-ups is essential for peak performance. Accurately dial in your carbs. with one of these Carburetor Synchronizers. Our P/N: 5746 is the original, SU type, bubble gauge with pivoting gauge tube for down-draft or side-draft applications. P/N: 43-5712 includes two Adapters which allows for 1-tool usage on a wide spectrum of applications. The Pro-Synchronizer will not restrict airflow and features an easy to read 1-30 kg/h numbered scale for precise synchronization.

- 5746 SU Type Carburetor Synchronizer
- 43-5712 EMPI Universal Pro-Sync, w/2 Adapters (Boxed)



## **CARBURETOR TOOLS**

These precision tools allow you to fine-tune your carburetors. The Jet Reamer Set features precision tapered reamers that cut to close tolerances. A selection of tapered reamers is packed in a protective plastic case. Know exactly what size you have cut your jets to with our Jet Size Gauges. Two size range gauges are available to fit all applications.

- 43-5715 Jet Reamer Kit
- 43-5716 Jet Gauge, .45mm - 1.50mm Range
- 43-5717 Jet Gauge, 1.50mm - 3.00mm Range



## **CIS FUEL INJECTOR PULLER**

Easily removes CIS fuel injectors.

- 5787 CIS Fuel Injector Puller



## **INJECTION PUMP LOCKING PIN**

Locks diesel injection pump in place when changing the camshaft belt.

- 5780 Injection Pump Locking Pin



## **VW & AUDI STRUT NUT SOCKET**

Removes/installs top shock retaining nut.

- 5825 Strut Nut Socket



## **COIL SPRING COMPRESSOR**

Safely remove coil springs from struts. Tightens and compresses springs together.

- 5728 Coil Spring Compressor, Pair

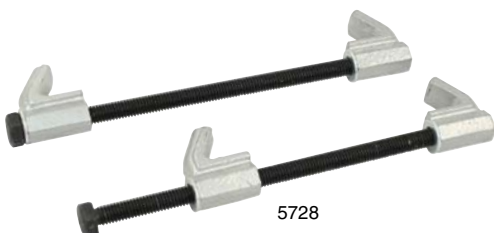



## **TIE ROD PULLER**

The design of this tool makes removal of the tie rod ends quick and easy without tearing the boots. Compact size allows you to carry the tool along on off-road outings for fast repairs in the field.

**B708000** **NEW!** Tie Rod End Puller 18mm to 25mm Rods



B708000

## **TIMING LIGHT**

Here's a tool nobody can do without. This static timing light is just what every tool box needs. Utilizes alligator clips for ease of timing and insuring good contact.

**B700900** **NEW!** Static Timing Light



B700900

## **OIL PISTON PULLER**

This quality tool has been designed to remove the oil pressure relief piston in VW engines. A piston which many times becomes stuck due to corrosion and gunk build-up and which should be cleaned for proper piston operation. With the tool's tip expanded, it grabs hold of the piston, pulling it out along with the tool. This precision made tool is a necessity when overhauling a VW engine, checking out oil pressure problems, or installing our oil piston and H.D. Spring kit.

**B700200** **NEW!** Oil Piston Puller



B700200

## **STARTER BUSHING TOOL**

Here's the answer when changing or repairing starter bushings. This tool is made to a high quality professional grade to give you years of trouble free service. The remover is designed to be used with only the starter removed.

**B706211** **NEW!** Starter Bushing Puller, 12V



B706211

## **PINION NUT SOCKET**

This quality tool solves the problem of removing and replacing the round nut that retains the pinion bearing in the 61-79 T-1 and 61-67 T-2 VWs. Believe us, this tool can be a life saver or stubborn pinion nuts.

**B706525** **NEW!** Pinion Nut Socket



B706525



## EMPI Universal Clamps - 7mm Wide



- 86-5831** Universal Stainless Steel Clamp, Small, 7mm Wide, 7" Long (100 pcs. in Poly Bag)
- 86-5833** Universal Stainless Steel Clamp, Small, 7mm Wide, 7" Long (10 pcs. in Poly Bag)

---

- 86-5832** Universal Stainless Steel Clamp, Large, 7mm Wide, 14.5" Long (100 pcs. in Poly Bag)
- 86-5834** Universal Stainless Steel Clamp, Large, 7mm Wide, 14.5" Long (10 pcs. in Poly Bag)

---

- 86-5837** Universal Stainless Steel Clamp, Extra Large, 7mm Wide, 16.5" Long (100 pcs. in Poly Bag)
- 86-5838** Universal Stainless Steel Clamp, Extra Large, 7mm Wide, 16.5" Long (10 pcs. in Poly Bag)

**Uses standard crimp pliers. Clamps are shipped wrapped (Round).**

## EMPI Universal Clamps - 7mm Wide



EMPI's Stainless Steel Universal Clamps are 7mm wide and are supplied in lengths of 365mm and 750mm, which will fit all C.V. Boots currently in use. These are the same type of clamp as used in all EMPI C.V. Joint Kits. Easy installation. **No special tools required. Use common pliers to pull tight and close Buckle. Clamps are shipped wrapped (Round).**

- 86-5795** Universal Clamp Kit, Pair (1-365mm and 1-750mm Clamp, Skinpacked)

---

- 86-5365** Universal Clamp 7mm Wide, 365mm Long (100 pcs. in Poly Bag)
- 86-5366** Universal Clamp 7mm Wide, 365mm Long (10 pcs. in Poly Bag)
- 86-5750** Universal Clamp 7mm Wide, 750mm Long (100 pcs. in Poly Bag)
- 86-5751** Universal Clamp 7mm Wide, 750mm Long (10 pcs. in Poly Bag)

## EMPI Band and Buckle Clamps - 7mm Wide

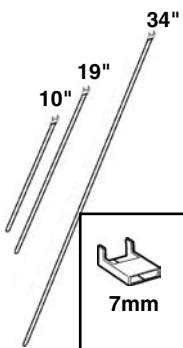

EMPI's Stainless Steel Band Clamps with retaining buckles are 7mm wide and are supplied in lengths of 10", 19" and 34" for 7mm width. **Installation tool 86-5792 is required. Clamps are shipped flat.**

- 86-5780** Band Clamp 7mm Wide, 10" Long (100 pcs. in Poly Bag)
- 86-5781** Band Clamp 7mm Wide, 19" Long (100 pcs. in Poly Bag)
- 86-5794** Band Clamp 7mm Wide, 34" Long (100 pcs. in Poly Bag)
- 86-5793** **7mm Buckles** for 86-5780, 86-5781, 86-5794, 86-5798 (100 pcs. in Poly Bag)

## Deluxe Installation Tool with Cutter



- 86-5792** Deluxe Tool with Ratchet and Cutter  
Used with the following Clamps:  
86-5780, 86-5781, 86-5794



# TOOLS & TOW BARS

## STANDARD DUTY TIE WRAPS

Keep wires, lines and hoses neatly in place and away from exhaust and other problem areas. Great for emergency use too. Made from UV resistant black nylon.

- 9320 Tie Wrap Kit, 25 Assorted, Skin Packed
- 9321 Tie Wraps, Short, 3.9" x .098", 100 pcs., Skinpacked
- 86-5786 Tie Wraps, Short, 3.9" x .098", Pack of 100, Poly Bagged
- 9323 Tie Wraps, Long, 11.5" x .190", 100 pcs., Skinpacked
- 86-5787 Tie Wraps, Long, 11.5" x .190", Pack of 100, Poly Bagged
- 86-5830-C Tie Wraps, Long, 17.5" x .190", 100 pcs., Skinpacked
- 86-5830 Tie Wraps, Long, 17.5" x .190", 100 pcs., Poly Bagged



## HEAVY DUTY TIE WRAPS WITH STAINLESS STEEL TABS

Our Heavy Duty Tie Wraps have stainless steel lock tabs for added strength. Use to hold valuable items and expensive parts secure. Great for use on C.V. Boots, Rack and Pinion Boots, etc. Made from UV resistant black nylon.

- 86-5796-C H.D. Tie Wraps, 4.0" x .095", 100 pcs., Skinpacked
- 86-5796 H.D. Tie Wraps, 4.0" x .095", 100 pcs., Poly Bagged
- 86-5778-C H.D. Tie Wraps, 7.9" x .095", 100 pcs., Skinpacked
- 86-5778 H.D. Tie Wraps, 7.9" x .095", 100 pcs., Poly Bagged
- 86-5797-C H.D. Tie Wraps, 12" x .185", 100 pcs., Skinpacked
- 86-5797 H.D. Tie Wraps, 12" x .185", 100 pcs., Poly Bagged
- 86-5779-C H.D. Tie Wraps, 14.2" x .095", 100 pcs., Skinpacked
- 86-5779 H.D. Tie Wraps, 14.2" x .095", 100 pcs., Poly Bagged
- 86-5770 H.D. Tie Wraps, 21.2" x .275", 100 pcs., Poly Bagged



**Metal Tang for Positive Locking**

## RACERS TAPE

Tough racers tape is great for repairs or rollbar padding, etc. Most racers can't finish without it.

- 5008 Racers Tape, Grey
- 5009 Racers Tape, Black



## THREAD SEALING TAPE

A must to seal all threaded fittings and joints. Use on oil and fuel line fittings.

- 9231 PTFE Thread Sealing Tape, Roll



## CAST IRON PAINT

- 86-3148 EMPI Cast Iron Paint
- Sold by the case only (12 Cans)
- CANNOT be shipped via AIR**



86-3148

## BOOKS & MANUALS

A collection of the best Tech Manuals available. Learn everything from engine, body, electrical and paint repair to Hot Rodding your engine. Invaluable reference that will save you time and money for as long as you own your VW.

### VW TECH BOOKS

Bentley technical manuals. Detailed reference for particular years and models as only VW could offer.

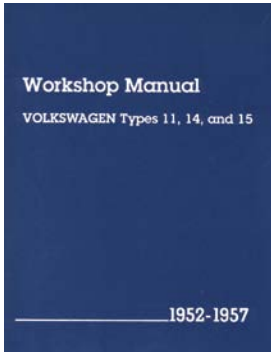

11-1011

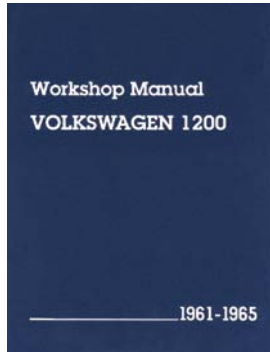

11-0601

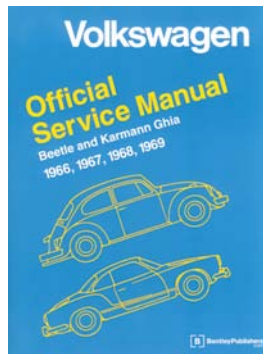

11-0701

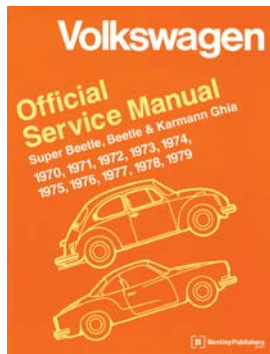

11-0800

11-1011  
11-1012  
11-0601  
11-0701  
11-0800

Type 1, 52-57  
Type 1, 58-60  
Type 1, 61-65  
Type 1, 66-69  
Type 1, 70-79

11-0988  
11-0987  
11-0909  
11-0975

Type 2, 50-62  
Type 2, 63-67  
Type 2, 68-79  
Vanagon, 80-91



11-0987

11-1006

Type 3, 68-73

11-0950

Rab/Scir, 75-79

11-0983

Dasher, 74-81

11-0976

Passat, 95-97, 2 Vol.

11-1008

'Portrait of a Legend' Type 1 Photo Book, Each

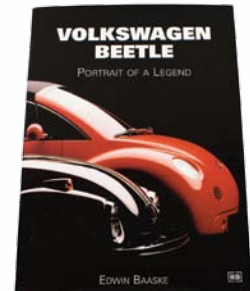

11-1008

11-1012

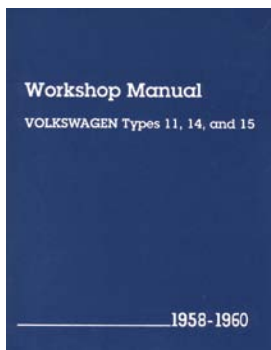

11-1012

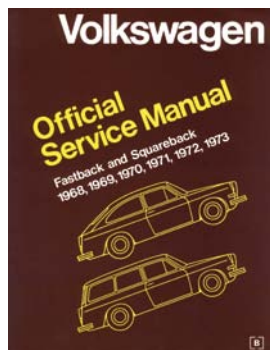

11-1006

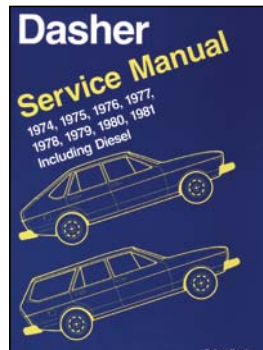

11-0983



## BOOKS & MANUALS (Continued)

### "IDIOT BOOK"

"How to Keep Your VW Alive" in plain English.  
Great for the beginner or the pro!

11-0990 "Idiot Book" - English

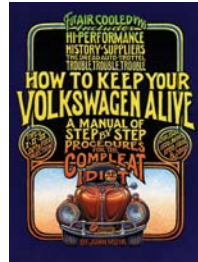

11-0990

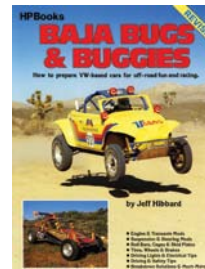

11-0205

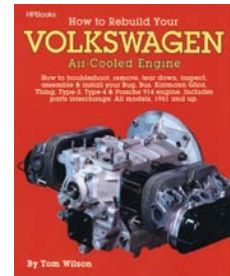

**NEW!** 11-1033

### BAJA BUGS & BUGGIES

How to prepare VW based cars for off-road and racing.

11-0205 Baja Bugs & Buggies

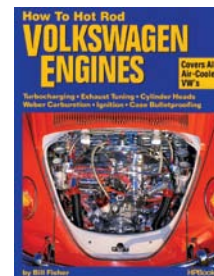

11-1032

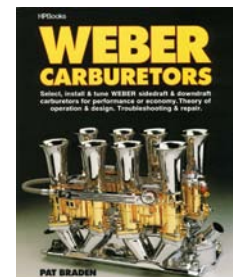

11-1050

### H.P. BOOKS

Specialty books.

11-1033 **NEW!** HP Rebuild VW Engines  
11-1032 HP Hot Rod VW Engines  
11-1031 HP Welders Handbook  
11-1050 HP Weber Carburetors

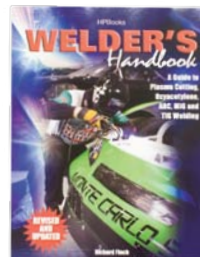

11-1031

### BOSCH AUTOMOTIVE MANUALS

Bosch technical expertise is shared in these manuals.

11-1063 Bosch, Brake Systems  
11-1064 Bosch, Diesel Fuel Injection  
11-1065 Bosch, VW Emission

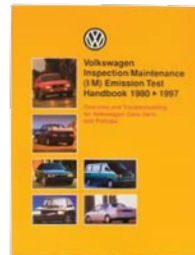

11-1065

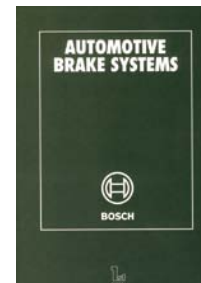

11-1063

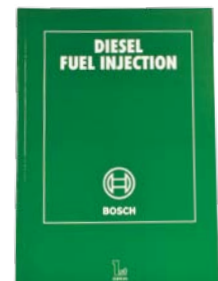

11-1064

### HAYNES REPAIR MANUALS

Every Haynes Manual is based on a complete tear-down and rebuild of the subject vehicle.

11-1070 Haynes, Bug/Ghia, 54-79  
11-1071 Haynes, Vanagon, 80-83  
11-1078 Haynes, Bus, 68-79  
11-1079 Haynes, Type, 3 63-73



11-1070

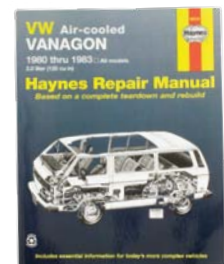

11-1071

11-1077 Weber Tuning Manual



11-1077

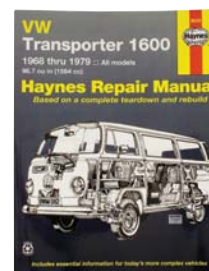

11-1078

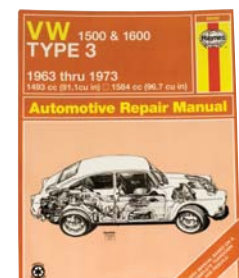

11-1079

# PROMO ITEMS



## EMPI T-SHIRTS

Quality preshrunk 100% cotton with colorful EMPI designs. All shirts supplied in individual poly bags. (Pictures shown are back of shirts). All shirts are white unless specified.

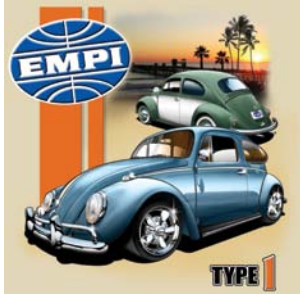

15-4052 - 15-4056

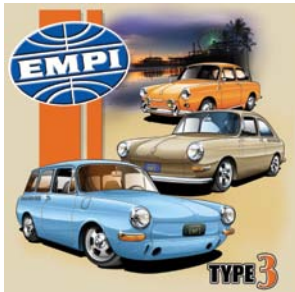

15-4074 - 15-4078

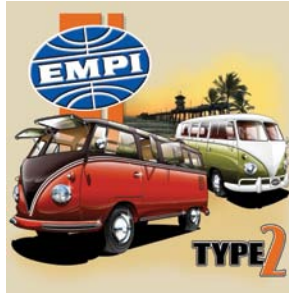

15-4069 - 15-4073



Front Design for Type 1, Type 2, Type 3, and Ghia shirts



15-4079 - 15-4083



9860-9864  
(Back)



9855-9859  
(Front & Back)

### EMPI TYPE 1

- 15-4052-0 EMPI Type 1, Small (Tan shirt)
- 15-4053-0 EMPI Type 1, Medium (Tan shirt)
- 15-4054-0 EMPI Type 1, Large (Tan shirt)
- 15-4055-0 EMPI Type 1, X Large (Tan shirt)
- 15-4056-0 EMPI Type 1, XX Large (Tan shirt)

### EMPI TYPE 2

- 15-4069-0 EMPI Type 2, Small (Tan shirt)
- 15-4070-0 EMPI Type 2, Medium (Tan shirt)
- 15-4071-0 EMPI Type 2, Large (Tan shirt)
- 15-4072-0 EMPI Type 2, X Large (Tan shirt)
- 15-4073-0 EMPI Type 2, XX Large (Tan shirt)

### EMPI TYPE 3

- 15-4074-0 EMPI Type 3, Small (Tan shirt)
- 15-4075-0 EMPI Type 3, Medium (Tan shirt)
- 15-4076-0 EMPI Type 3, Large (Tan shirt)
- 15-4077-0 EMPI Type 3, X Large (Tan shirt)
- 15-4078-0 EMPI Type 3, XX Large (Tan shirt)

### EMPI GHIA

- 15-4079-0 EMPI Ghia, Small (Tan shirt)
- 15-4080-0 EMPI Ghia, Medium (Tan shirt)
- 15-4081-0 EMPI Ghia, Large (Tan shirt)
- 15-4082-0 EMPI Ghia, X Large (Tan shirt)
- 15-4083-0 EMPI Ghia, XX Large (Tan shirt)

### EMPI 3 CAR (Front: EMPI Logo Only)

- 9860 EMPI, Small
- 9861 EMPI, Medium
- 9862 EMPI, Large
- 9863 EMPI, X Large
- 9864 EMPI, XX Large

### EMPI RACING TEAM

- 9855 EMPI Racing Team, Small
- 9856 EMPI Racing Team, Medium
- 9857 EMPI Racing Team, Large
- 9858 EMPI Racing Team, X Large
- 9859 EMPI Racing Team, XX Large



# PROMO ITEMS

## EMPI T-SHIRTS (Continued)

### EMPI NEW BEETLE INCH PINCHER

- 9804 EMPI NB Inch Pincher, Childs 10-12
- 9805 EMPI NB Inch Pincher, Small
- 9806 EMPI NB Inch Pincher, Medium
- 9807 EMPI NB Inch Pincher, Large
- 9808 EMPI NB Inch Pincher, X Large
- 9809 EMPI NB Inch Pincher, XX Large



9804-9809 (Front and Rear Lg.)

### EMPI 3-CAR INCH PINCHER

- 15-4047 EMPI 3-Car Inch Pincher, Small
- 15-4048 EMPI 3-Car Inch Pincher, Medium
- 15-4049 EMPI 3-Car Inch Pincher, Large
- 15-4050 EMPI 3-Car Inch Pincher, X Large
- 15-4051 EMPI 3-Car Inch Pincher, XX Large



15-4047-15-4051

### EMPI AMERICAN CLASSIC

- 15-4023 EMPI American Classic, Orange, Small
- 15-4024 EMPI American Classic, Orange, Medium
- 15-4025 EMPI American Classic, Orange, Large
- 15-4026 EMPI American Classic, Orange, X-Large
- 15-4027 EMPI American Classic, Orange, XX-Large



15-4023 - 15-4027

### EMPI EPC 51/SIZE DOES MATTER

- 15-4029 EMPI EPC 51/Size Does Matter, Small
- 15-4030 EMPI EPC 51/Size Does Matter, Medium
- 15-4031 EMPI EPC 51/Size Does Matter, Large
- 15-4032 EMPI EPC 51/Size Does Matter, X-Large
- 15-4033 EMPI EPC 51/Size Does Matter, XX-Large

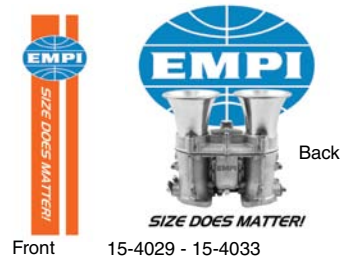

15-4029 - 15-4033

### EMPI JACKET

Colorful blue Cotton blend with orange and white racing stripe for the retro look!

- 15-4062 EMPI Jacket, Medium
- 15-4063 EMPI Jacket, Large
- 15-4064 EMPI Jacket, X-Large
- 15-4065 EMPI Jacket, XX-Large
- 15-4066 EMPI Logo Patch, 7 3/4" x 5 3/8", Each
- 15-4067 EMPI Logo Patch, 3 11/16" x 2 9/16", Each
- 15-4068 EMPI Logo Patch, 2 3/4" x 2", Each
- 15-4084 **NEW!** EMPI Power Rules Patch, 2 3/4" x 4 1/8", Each



15-4067

**NEW!** 15-4084

# PROMO ITEMS



Front



Back

15-4034-15-4038

## AUTO HAUS

- 15-4034 Auto Haus, Small
- 15-4035 Auto Haus, Medium
- 15-4036 Auto Haus, Large
- 15-4037 Auto Haus, X Large
- 15-4038 Auto Haus, XX Large



Front



Back

B950912 - B950914

## BUGPACK LOGO

- B950912 **NEW!** Bugpack Logo, Large (White)
- B950913 **NEW!** Bugpack Logo, X Large (White)
- B950914 **NEW!** Bugpack Logo, XX Large (White)



Front



Back

B950922 - B950924

## BUGPACK LOGO

- B950922 **NEW!** Bugpack Logo, Large (Black)
- B950923 **NEW!** Bugpack Logo, X Large (Black)
- B950924 **NEW!** Bugpack Logo, XX Large (Black)



9891

9892

9893

## EMPI CAPS

EMPI baseball caps. High or low profile featuring registered EMPI Logo.

- 9891 EMPI Deluxe Cap, White w/Blue Visor, w/Embroidered Logo
- 9892 EMPI Deluxe Cap, Low Profile, Black, w/Embroidered Logo
- 9893 EMPI Cap, White w/Blue Visor, w/Screened Logo



# PROMO ITEMS

## EMPI STICKERS

- 9810 EMPI Oval, 1 3/4" x 1 1/4", Pack of 100
- 9811 EMPI Oval, 7 3/4" x 5 1/2", Pack of 10
- 9815 EMPI Oval, 3 1/4" x 2 1/4", Pack of 100
- 9820 EMPI Oval Extra Large 14" x 11", Each
  
- 9816 EMPI Power Rules, 4" x 2 3/4", Pack of 100
- 9817 EMPI Equipped, 3" x 3", Pack of 100
  
- 9802 CAUTION 200 M.P.H., 3 3/4" x 1 1/2", Pack of 100
- 15-4041 EMPI WEBER Decal, Pack of 100
  
- 15-4046 Auto-Haus Logo, 4" x 3", Pack of 100



9816



9810/9811/9815/9820



9802



9817



15-4046

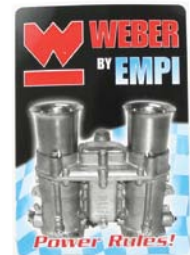

15-4041

## EMPI COFFEE MUGS

- 9897 EMPI Mug, New Beetle Inch Pincher
- 9898 EMPI Mug, Axle Man



9898



9897

## EMPI DEALER ITEMS

- 9843 EMPI Inventory Tags, Pack of 25
- 9812 EMPI Cardboard Sign 22" x 14"
- 9819 EMPI Authorized Distributor (two sided) 16" x 9", Store Window Decal, Each
- 9870 EMPI Banner 36" x 24", Each Orange Vinyl w/ eyelets, Printed Blue & White Oval
- 9899 **NEW!** EMPI Large Banner, 36" x 120", Each Orange Vinyl w/ eyelets, Printed Blue & White Oval



9843



9812



**NEW!** 9899



9870

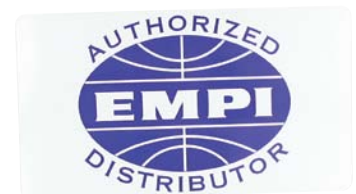

9819

# ALL NEW COMPLETE DRIVE AXLES



90-6900



- New EMPI C.V. Joints - Inner and Outer
- New EMPI Boots and Stainless Steel Clamps
- New EMPI Clips and Hardware
- New EMPI Center Shaft
- New EMPI Parts
- Loaded with EMPI Black Moly Grease and individually boxed

YEAR SPECIFICATIONS DRIVER PSGR.

## Volkswagen

### Volkswagen Axle Mounting Hardware (Outboard)

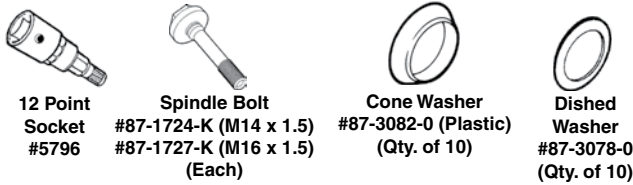

<b>12 Point Socket</b> #5796	<b>Spindle Bolt</b> #87-1724-K (M14 x 1.5) #87-1727-K (M16 x 1.5) (Each)	<b>Cone Washer</b> #87-3082-0 (Plastic) (Qty. of 10)	<b>Dished Washer</b> #87-3078-0 (Qty. of 10)
---------------------------------	---	--	--

### Volkswagen Axle Mounting Hardware (Inboard)

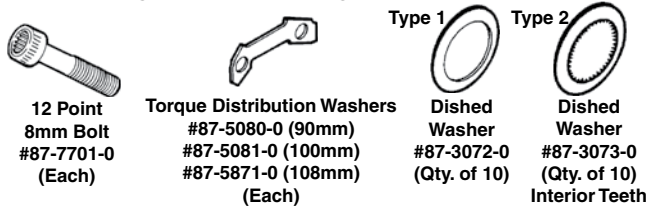

<b>12 Point 8mm Bolt</b> #87-7701-0 (Each)	<b>Torque Distribution Washers</b> #87-5080-0 (90mm) #87-5081-0 (100mm) #87-5871-0 (108mm) (Each)	<b>Dished Washer</b> #87-3072-0 (Qty. of 10)	<b>Dished Washer</b> #87-3073-0 (Qty. of 10) Interior Teeth
--	---	--	--

**Additional hardware available for all axle assemblies - Inquire with your salesperson.**

### #23 Volkswagen Inboard Joints O.D.

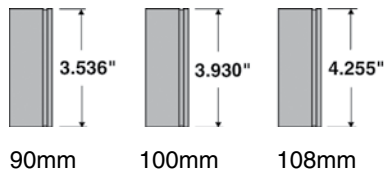

<b>Beetle, Karmann Ghia, Type 1 (Rear Axles)</b>	
68-79	w/ IRS ..... 90-6900 ...90-6900
<b>Thing (Rear Axles)</b>	
73-75	w/ IRS ..... 90-6905 ...90-6905
<b>Type III, Fastback, Squareback (Rear Axles)</b>	
69-73	A/T, w/ IRS ..... 90-6907 ...90-6906
	M/T, w/ IRS ..... 90-6900 ...90-6900
<b>Type IV, 411, 412 (Rear Axles)</b>	
71-74	w/ IRS ..... 90-6800 ...90-6800

## Volkswagen SUV/Truck/Van

<b>Type II, Transporter (Rear Axles)</b>	
68-79	A/T, w/ IRS ..... 90-6901 ...90-6902
	M/T, w/ IRS ..... 90-6903 ...90-6903

YEAR SPECIFICATIONS DRIVER PSGR.

## Volkswagen (Continued)

<b>Vanagon (Rear Axles)</b>	
83-92	A/T ..... 90-6804 ...90-6803
	M/T ..... 90-6805 ...90-6805
80-82	A/T ..... 90-6800 ...90-6801
	M/T ..... 90-6802 ...90-6802

<b>Vanagon Syncro AWD (Rear Axles)</b>	
86-92	..... 90-6805 ...90-6805





# C.V. JOINT KITS & COMPONENTS

EMPI Constant Velocity Joint Kits come packaged in our distinctive 3-Color Tri-Lingual Box. All Constant Velocity Joints are sold each (1) per part number. Kits Include the following:

- New C.V. Joint
- New Spindle Nut (if applicable)
- New C.V. Boot and Stainless Steel Clamps
- New Retaining Clip and Hardware (if applicable)
- New Moly Grease Packed in Outboards
- 4 oz. Packet supplied with Inboards
- C.V. Joint Only (Bulk) is also Available



## Reference Info. Inboard Joint O.D.

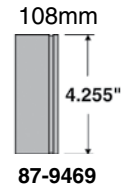
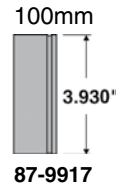
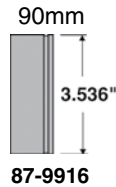

MODEL	POSITION	YEARS	SPECIFICATION / SIDE	JOINT KIT	BULK JOINT	NUT ONLY
<b>Volkswagen</b>						
Beetle (Ghia)	Both	67-79	Rear, IRS, (90mm)	87-9916-K	87-9916-0	N/R
Dasher	Inboard	74-81	(90mm)	87-9916-K	87-9916-0	N/R
Fox	Inboard	87-93	(90mm)	87-9916-K	87-9916-0	N/R
Golf	Inboard	85-92	GL & GT, (90mm)	87-9916-K	87-9916-0	N/R
Jetta	Inboard	80-92	GL & GT, (90mm)	87-9916-K	87-9916-0	N/R
Quantum (2WD)	Inboard	82-85	4 Cyl., (90mm)	87-9916-K	87-9916-0	N/R
		82-83	5 Cyl., To Ch. # 32-D-092 500, (90mm)	87-9916-K	87-9916-0	N/R
Quantum Syncro	Inboard	85-87	Rear, To Ch. # 33-H-086 636, (90mm)	87-9916-K	87-9916-0	N/R
Rabbit (Incl. Pickup)	Inboard	74-84	(90mm)	87-9916-K	87-9916-0	N/R
Scirocco	Inboard	75-83		87-9916-K	87-9916-0	N/R
		1984	A/T	87-9916-K	87-9916-0	N/R
		1984	M/T, To Ch. #53-E-040 254	87-9916-K	87-9916-0	N/R
		1985	A/T, To Ch. # 53-F-000 191	87-9916-K	87-9916-0	N/R
Type III	Both	68-73	Rear, IRS, (90mm)	87-9916-K	87-9916-0	N/R
<b>Volkswagen SUV/Truck/Van</b>						
Transporter, Type II	Both	68-79	Rear, IRS, (100mm)	87-9917-K	87-9917-0	N/R
Vanagon (2WD)	Both	80-92	Rear, (100mm)	87-9917-K	87-9917-0	N/R
Vanagon Syncro (4WD)	Inboard	86-92	Front, (100mm)	87-9917-K	87-9917-0	N/R
		86-92	Rear, (100mm)	87-9917-K	87-9917-0	N/R

# C.V. JOINT KITS & COMPONENTS



MODEL	POSITION	YEARS	SPECIFICATION / SIDE	JOINT KIT	BULK JOINT	NUT ONLY
<b>Volkswagen (Mexico Produced)</b>						
Atlantic	Inboard	77-87	(90mm)	87-9916-K	87-9916-0	N/R
Caribe	Inboard	77-87	(90mm)	87-9916-K	87-9916-0	N/R
Combi	Both	70-97	Rear, IRS, (100mm)	87-9917-K	87-9917-0	N/R
Corsar	Inboard	85-87	(90mm)	87-9916-K	87-9916-0	N/R
Golf	Inboard	87-91	(90mm)	87-9916-K	87-9916-0	N/R
Jetta	Inboard	87-91	(90mm)	87-9916-K	87-9916-0	N/R

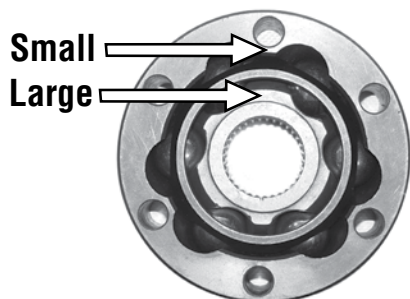

**Tip:** When assembling a cross groove style C.V. joint, be sure that the narrow points of the outer housing are aligned with the wide areas of the race. Improper indexing of C.V. joint will limit it's ability to plunge causing immediate failure.





# C.V. BOOT KITS

Complete with Boot, Stainless Steel Clamps, Grease and Installation Instructions. EMPI Constant Velocity Boot Kits come packaged in our distinctive 3-Color Trilingual Box. If no side designation is made then the boot fits both left and right side.



YEARS	SPECIFICATIONS	SIDE	INNER	OUTER
<b>Volkswagen</b>				
<b>Beetle (New)</b>				
1998.....	1.9L, M/T, .....	Left.....	N/A .....	86-2375-D
		Right ...	86-1185-D...	86-2375-D
	2.0L, A/T .....		86-2188-D...	86-2375-D
99-01 .....	1.8L, A/T .....		86-2359-D...	86-2375-D
	1.8L, M/T, .....	Left.....	86-1184-D...	86-2375-D
		Right ...	86-1185-D...	86-2375-D
	1.9L, A/T .....		86-2359-D...	86-2375-D
	1.9L, M/T, .....	Left.....	N/A .....	86-2375-D
		Right ...	86-1185-D...	86-2375-D
	2.0L, A/T .....		86-2359-D...	86-2375-D
	2.0L, M/T, .....	Left.....	86-1184-D...	86-2375-D
		Right ...	86-1185-D...	86-2375-D
2002.....	1.8L, A/T .....		86-2254-D...	86-2375-D
	1.8L, M/T (5 Spd.).....		86-2254-D...	86-2375-D
	1.8L, M/T (6 Spd.).....		86-1100-D...	86-2319-D
	1.9L, A/T .....		86-2254-D...	86-2375-D
	1.9L, M/T .....	Left.....	N/A .....	86-2375-D
		Right ...	86-1185-D...	86-2375-D
	2.0L, A/T .....		86-2254-D...	86-2375-D
	2.0L, M/T .....		86-2413-D...	86-2375-D
03-04 .....	1.8L, A/T (4 Spd.).....		86-2254-D...	86-2375-D
	1.8L, A/T (6 Spd.).....		86-2422-D...	86-2337-D
	1.8L, M/T (5 Spd.).....		86-2254-D...	86-2375-D
	1.8L, M/T (6 Spd.).....		86-1100-D...	86-2319-D
	1.9L, A/T .....		86-2254-D...	86-2375-D
	1.9L, M/T .....	Left.....	N/A .....	86-2375-D
		Right ...	86-1185-D...	86-2375-D
	2.0L, A/T (4 Spd.).....		86-2254-D...	86-2375-D
	2.0L, A/T (6 Spd.).....		86-2422-D...	86-2337-D
	2.0L, M/T .....		86-2413-D...	86-2375-D
2005.....	1.8L, A/T .....		86-2422-D...	86-2337-D
	1.8L, M/T .....		86-2254-D...	86-2375-D
	1.9L, A/T .....		86-2254-D...	86-2375-D
	1.9L, M/T .....	Left.....	N/A .....	86-2375-D
		Right ...	86-1185-D...	86-2375-D
	2.0L, A/T .....		86-2422-D...	86-2337-D
	2.0L, M/T .....		86-2413-D...	86-2375-D
2006.....	1.9L, M/T .....	Left.....	N/A .....	86-2375-D
		Right ...	86-1185-D...	86-2375-D

YEARS	SPECIFICATIONS	SIDE	INNER	OUTER
<b>Volkswagen</b>				
<b>Beetle (New) (cont.)</b>				
06-10 .....	2.5L, A/T .....		86-2432-D...	86-2338-D
	2.5L, M/T .....		N/A .....	86-2375-D
2011.....	Not Produced This Year			
2012.....	2.0L, A/T .....		86-2452-D...	86-2338-D
	2.0L, M/T .....		N/A .....	86-2375-D
	2.5L, A/T .....		86-2432-D...	86-2375-D
	2.5L, M/T .....		N/A .....	86-2375-D
<b>Beetle, Ghia</b>				
thru 68 ...	Swing Axle .....		86-1091-D.....	N/R
68-79 .....	IRS .....		86-1084-D...	86-1084-D
<b>Cabriolet, Cabrio</b>				
85-93 .....		Left.....	86-1184-D...	86-1101-D
		Right ...	86-1185-D...	86-1101-D
95-96 .....		Left.....	86-1184-D...	86-2375-D
		Right ...	86-1185-D...	86-2375-D
97-02 .....	A/T .....		86-2188-D...	86-2375-D
	M/T.....	Left.....	86-1184-D...	86-2375-D
		Right ...	86-1185-D...	86-2375-D
<b>CC</b>				
2009.....	2.0, A/T, To 12/31/08 .....		86-2424-D...	86-2338-D
	2.0, A/T, From 1/1/09.....		86-2421-D...	86-2338-D
	2.0L, M/T .....		86-2452-D...	86-2338-D
	Front, 3.6L.....		86-2421-D...	86-2338-D
	<b>Rear</b> , 3.6L .....		86-2413-D...	86-2375-D
10-13 .....	2.0L, A/T .....		86-2452-D...	86-2338-D
	2.0L, M/T .....		86-2452-D...	86-2338-D
	Front, 3.6L.....		86-2421-D...	86-2338-D
	<b>Rear</b> , 3.6L .....		86-2413-D.....	N/A
<b>Corrado</b>				
90-91 .....	1.8L.....	Left.....	86-2413-D...	86-1101-D
		Right ...	86-1185-D...	86-1101-D
1992.....	1.8L.....	Left.....	86-2413-D...	86-2375-D
		Right ...	86-1185-D...	86-2375-D
92-95 .....	2.8L.....	Left.....	86-2413-D...	86-2375-D
		Right ...	86-1185-D...	86-2375-D
<b>Dasher</b>				
74-81 .....			86-1084-D...	86-1085-D

YEARS SPECIFICATIONS SIDE INNER OUTER

## Volkswagen (Continued)

YEARS	SPECIFICATIONS	SIDE	INNER	OUTER
<b>Eos</b>				
07-08	2.0L		86-2452-D	86-2338-D
	3.2L		86-2424-D	86-2338-D
09-12	2.0L		86-2452-D	86-2338-D
<b>Fox</b>				
87-93			86-1084-D	86-1085-D
<b>Golf (Old Body)</b>				
85-92	Exc. GT, GTi		86-1084-D	86-1085-D
	GT, GTi, (Exc. 90-92 2.0L GTi)			
		Left	86-1184-D	86-1101-D
		Right	86-1185-D	86-1101-D
90-92	2.0L GTi		86-2413-D	86-1101-D
93-96	1.8L, Gas	Left	86-1184-D	86-2375-D
		Right	86-1185-D	86-2375-D
93-95	1.9L, Diesel	Left	86-1184-D	86-2375-D
		Right	86-1185-D	86-2375-D
95-96	2.8L	Left	86-2413-D	86-2375-D
		Right	86-1185-D	86-2375-D
96-99	1.9L, Diesel	Left	N/A	86-2375-D
		Right	86-1185-D	86-2375-D
97-99	1.8L, A/T		86-2188-D	86-2375-D
	1.8L, M/T	Left	86-1184-D	86-2375-D
		Right	86-1185-D	86-2375-D
	2.8L, A/T		86-2188-D	86-2375-D
	2.8L, M/T	Left	86-1184-D	86-2375-D
		Right	86-1185-D	86-2375-D
<b>Golf (New Body)</b>				
99-01	1.8L, Gas		86-2359-D	86-2375-D
	1.9L, Diesel, A/T		86-2359-D	86-2375-D
	1.9L, Diesel, M/T	Left	N/A	86-2375-D
		Right	86-1185-D	86-2375-D
	2.0L, A/T		86-2359-D	86-2375-D
	2.0L, M/T	Left	86-1184-D	86-2375-D
		Right	86-1185-D	86-2375-D
	2.8L, A/T		86-2359-D	86-2375-D
	2.8L, M/T	Left	86-1184-D	86-2375-D
		Right	86-1185-D	86-2375-D
2002	1.8L, A/T		86-2365-D	86-2319-D
	1.8L, M/T		86-1100-D	86-2375-D
	1.9L, A/T		86-2359-D	86-2375-D
	1.9L, M/T	Left	N/A	86-2375-D
		Right	86-1185-D	86-2375-D
	2.0L, M/T	Left	86-2413-D	86-2375-D
		Right	86-1185-D	86-2375-D
	2.8L		86-2359-D	86-2375-D
2003	1.8L, A/T		86-2365-D	86-2319-D
	1.8L, M/T		86-1100-D	86-2375-D
	1.9L, A/T		86-2254-D	86-2375-D
	1.9L, M/T	Left	N/A	86-2375-D
		Right	86-1185-D	86-2375-D
	2.0L, A/T		86-2254-D	86-2375-D

YEARS SPECIFICATIONS SIDE INNER OUTER

## Volkswagen (Continued)

YEARS	SPECIFICATIONS	SIDE	INNER	OUTER
<b>Golf (New Body)</b>				
2003	2.0L, M/T	Left	86-2413-D	86-2375-D
		Right	86-1185-D	86-2375-D
	2.8L		N/A	86-2319-D
2004	1.8L, A/T		86-2365-D	86-2319-D
	1.8L, M/T		86-2254-D	86-2375-D
	1.9L, A/T		86-2254-D	86-2319-D
	1.9L, M/T	Left	86-2413-D	86-2375-D
		Right	86-1185-D	86-2375-D
	2.8L		N/A	86-2319-D
	Front, 3.2L		86-2452-D	86-2319-D
2005	1.8L, A/T		86-2365-D	86-2319-D
	1.8L, M/T		86-2254-D	86-2375-D
	1.9L, A/T		86-2365-D	86-2319-D
	1.9L, M/T	Left	86-2413-D	86-2375-D
		Right	86-1185-D	86-2375-D
	2.0L, A/T		86-2254-D	86-2375-D
	2.0L, M/T	Left	86-2413-D	86-2375-D
		Right	86-1185-D	86-2375-D
	2.8L		N/A	86-2319-D
2006	1.8L, A/T		86-2365-D	86-2319-D
	1.8L, M/T		86-2254-D	86-2375-D
	1.9L, A/T		86-2365-D	86-2319-D
	1.9L, M/T	Left	86-2413-D	86-2375-D
		Right	86-1185-D	86-2375-D
	2.0L, A/T		86-2254-D	86-2375-D
	2.0L, M/T	Left	86-2413-D	86-2375-D
		Right	86-1185-D	86-2375-D
07-09	Not produced these years			
10-13	2.0L, 6 Spd. A/T (Dual Clutch)		86-2421-D	86-2338-D
			86-2452-D	86-2338-D
	2.5L, 6 Spd. A/T (Dual Clutch)		86-2426-D	86-2375-D
			86-2413-D	86-2375-D
2004	<b>Rear</b> , 3.2L		86-2413-D	86-2389-D
<b>GLi</b>				
08-09			86-2452-D	86-2338-D
12-13	A/T		86-2452-D	86-2338-D
	M/T		86-2452-D	86-2338-D
<b>GTI</b>				
06-13			86-2452-D	86-2338-D
<b>Jetta (Old Body)</b>				
81-92	Exc. GL, GLi		86-1084-D	86-1085-D
1985	GL, GLi, I6V	Left	86-1184-D	86-1085-D
		Right	86-1185-D	86-1085-D
86-87	GL, GLi, I6V	Left	86-1184-D	86-1101-D
		Right	86-1185-D	86-1101-D
1988	GLi, To 16-J-097-865			
		Left	86-2137-D	86-1101-D
		Right	86-1185-D	86-1101-D



# C.V. BOOT KITS

YEARS SPECIFICATIONS SIDE INNER OUTER

## Volkswagen (Continued)

### Jetta (Old Body) (cont.)

88-92	..... GLi, From 16-J-097-866, (Exc. GLi 2.0L)	Left.....	86-2413-D	.....	86-1085-D
		Right ...	86-1185-D	.....	86-1085-D
90-92	..... GLi 2.0L	Left.....	86-2413-D	.....	86-1085-D
		Right ...	86-1185-D	.....	86-1085-D
93-96	..... 1.8L, Gas	Left.....	86-1184-D	.....	86-2375-D
		Right ...	86-1185-D	.....	86-2375-D
93-95	..... 1.9L, Diesel	Left.....	86-1184-D	.....	86-2375-D
		Right ...	86-1185-D	.....	86-2375-D
95-96	..... 2.8L	Left.....	86-2413-D	.....	86-2375-D
		Right ...	86-1185-D	.....	86-2375-D
96-99	..... 1.9L, Diesel	Left.....	N/A	.....	86-2375-D
		Right ...	86-1185-D	.....	86-2375-D
97-99	..... 1.8L, A/T		86-2188-D	.....	86-2375-D
	1.8L, M/T	Left.....	86-1184-D	.....	86-2375-D
		Right ...	86-1185-D	.....	86-2375-D
97-99	..... 2.8L, A/T		86-2188-D	.....	86-2375-D
	2.8L, M/T	Left.....	86-1184-D	.....	86-2375-D
		Right ...	86-1185-D	.....	86-2375-D

### Jetta (New Body)

99-03	..... 1.8L, Gas		86-2359-D	.....	86-2375-D
	1.9L, Diesel, A/T		86-2359-D	.....	86-2375-D
	1.9L, Diesel, M/T	Left.....	N/A	.....	86-2375-D
		Right ...	86-1185-D	.....	86-2375-D
99-01	..... 2.0L, A/T		86-2359-D	.....	86-2375-D
	2.0L, M/T	Left.....	86-1184-D	.....	86-2375-D
		Right ...	86-1185-D	.....	86-2375-D
	2.8L, A/T		86-2359-D	.....	86-2375-D
	2.8L, M/T	Left.....	86-1184-D	.....	86-2375-D
		Right ...	86-1185-D	.....	86-2375-D
2002	..... 1.8L, A/T (Exc. GLS)		86-2359-D	.....	86-2375-D
	1.8L, A/T, GLS		86-2365-D	.....	86-2319-D
	1.8L, M/T (Exc. GLS)		86-2359-D	.....	86-2375-D
	1.8L, M/T, GLS		86-2359-D	.....	86-2319-D
	1.9L, A/T		86-2359-D	.....	86-2375-D
	1.9L, M/T		N/A	.....	86-2375-D
	2.0L, A/T		86-2359-D	.....	86-2375-D
	2.0L, M/T	Left.....	86-1184-D	.....	86-2375-D
		Right ...	86-1185-D	.....	86-2375-D
	2.8L, GSL, GSX (Engine Code AFD)		86-2359-D	.....	86-2375-D
	2.8L, (Engine Code BDF)		86-2365-D	.....	86-2319-D
2003	..... 1.8L, A/T		86-2365-D	.....	86-2319-D
	1.8L, M/T (To Ch #9M-3-163-228)		86-2359-D	.....	86-2375-D
	1.8L, M/T (From Ch #9M-3-163-229)		86-2359-D	.....	86-2375-D
	1.9L, A/T		86-2254-D	.....	86-2375-D
	1.9L, M/T (To Ch #9M-3-163-228)	Left.....	N/A	.....	86-2375-D
		Right ...	86-1185-D	.....	86-2375-D

YEARS SPECIFICATIONS SIDE INNER OUTER

## Volkswagen (Continued)

### Jetta (New Body) (cont.)

2003	..... 1.9L, M/T (Fr. Ch #9M-3-163-229)	Left.....	N/A	.....	86-2375-D
		Right ...	86-1185-D	.....	86-2375-D
	2.0L, A/T		86-2254-D	.....	86-2375-D
	2.0L, M/T (To Ch #9M-3-163-228)	Left.....	86-2413-D	.....	86-2375-D
		Right ...	86-1185-D	.....	86-2375-D
	2.0L, M/T (Fr. Ch #9M-3-163-229)	Left.....	86-2413-D	.....	86-2375-D
		Right ...	86-1185-D	.....	86-2375-D
	2.8L		86-2365-D	.....	86-2319-D
2004	..... 1.8L		86-2365-D	.....	86-2319-D
	1.8L, M/T (exc. GLS)		86-2359-D	.....	86-2375-D
	1.8L, M/T, GLS		86-2254-D	.....	86-2375-D
	1.9L, A/T (Engine Code ALH)		86-2254-D	.....	86-2375-D
	1.9L, A/T (Engine Code BEW)		86-2365-D	.....	86-2319-D
	1.9L, M/T (Engine Code ALH)	Left.....	N/A	.....	86-2375-D
		Right ...	86-1185-D	.....	86-2375-D
	1.9L, M/T (Engine Code BEW)	Left.....	N/A	.....	86-2375-D
		Right ...	86-1185-D	.....	86-2375-D
	2.0L, A/T		86-2254-D	.....	86-2375-D
	2.0L, M/T	Left.....	86-2413-D	.....	86-2375-D
		Right ...	86-1185-D	.....	86-2375-D
	2.8L (Engine Code BDF)		86-2365-D	.....	86-2319-D
	2.8L (Engine Code AFP)		86-2254-D	.....	86-2319-D
2005	..... 1.8L, A/T		86-2365-D	.....	86-2319-D
	1.8L, M/T	Left.....	86-2359-D	.....	86-2375-D
		Right ...	86-2254-D	.....	86-2365-D
	1.9L, A/T (Engine Code BEW)		86-2365-D	.....	86-2319-D
	1.9L, A/T (Engine Code BRM)		86-2424-D	.....	86-2319-D
	1.9L, M/T (Engine Code BEW)		N/A	.....	86-2375-D
	2.0L, A/T		86-2359-D	.....	86-2375-D
	2.0L, M/T		N/A	.....	86-2375-D
	2.5L, A/T		86-2426-D	.....	86-2375-D
2006	..... 1.9L		86-2413-D	.....	86-2375-D
06-09	..... 2.0L		86-2452-D	.....	86-2338-D
	2.5L, A/T		86-2432-D	.....	86-2338-D
	2.5L, M/T		86-2413-D	.....	86-2375-D
2010	..... 2.0L, Diesel, A/T		86-2424-D	.....	86-2338-D
	2.0L, Diesel, M/T		86-2452-D	.....	86-2338-D
	2.0L, Gas		86-2452-D	.....	86-2338-D
	2.5L, A/T		86-2432-D	.....	86-2338-D
	2.5L, M/T		86-2413-D	.....	86-2375-D



YEARS SPECIFICATIONS SIDE INNER OUTER

## Volkswagen (Continued)

### Jetta (New Body) (cont.)

2011	2.0L, Diesel, A/T	86-2424-D	86-2338-D
	2.0L, Diesel, M/T	86-2452-D	86-2338-D
	2.0L, Gas, A/T	86-2426-D	86-2375-D
	2.0L, Gas, M/T	86-2413-D	86-2375-D
	2.5L, A/T	86-2432-D	86-2338-D
	2.5L, M/T	86-2413-D	86-2375-D
12-13	2.0L, Diesel, A/T	86-2424-D	86-2338-D
	2.0L, Diesel, M/T	86-2452-D	86-2338-D
	2.0L, Gas, A/T, (Exc Gli)	86-2426-D	86-2375-D
	2.0L, Gas, A/T, (GLi)	86-2452-D	86-2338-D
	2.0L, Gas, M/T, (Exc. GLi)	86-2413-D	86-2375-D
	2.0L, Gas, M/T, (GLi)	86-2452-D	86-2338-D
	2.5L, A/T	86-2432-D	86-2338-D
	2.5L, M/T	86-2413-D	86-2375-D

### Passat (2WD)

90-94	Left	86-1184-D	86-2232-D
	Right	86-1185-D	86-2232-D
95-97	4 Cyl	N/A	86-2375-D
	Right	86-1185-D	86-2375-D
	6 Cyl	Left	86-1184-D
		Right	86-1185-D
98-01	4 Cyl, A/T	86-2188-D	86-2324-D
	4 Cyl, M/T	86-1100-D	86-2324-D
	6 Cyl	86-2188-D	86-2281-D
02-03	1.8L	86-2188-D	86-2281-D
	2.8L	86-2188-D	86-2281-D
	4.0L	86-2188-D	86-2281-D
2004	1.8L	86-2188-D	86-2281-D
	2.0L	86-2188-D	86-2281-D
	2.8L	86-2188-D	86-2281-D
	4.0L	86-2188-D	86-2281-D
2005	1.8L	86-2188-D	86-2281-D
	2.0L	86-2188-D	86-2281-D
	2.8L	86-2188-D	86-2281-D
06-08	2.0L, A/T	86-2424-D	86-2338-D
	2.0L, M/T	86-2452-D	86-2338-D
	3.6L	86-2421-D	86-2338-D
2009		86-2424-D	86-2338-D
2010		86-2452-D	86-2338-D
12-13	2.0L, A/T	86-2421-D	86-2338-D
	2.0L, M/T	86-2452-D	86-2338-D
	2.5L, A/T	86-2432-D	86-2375-D
	2.5L, M/T	N/A	86-2375-D
	3.6L	86-2452-D	86-2338-D

### Passat 4 Motion

99-01	Front	86-2188-D	86-2281-D
2002	Front, 2.8L, A/T	86-2188-D	86-2324-D
	Front, 2.8L, M/T	86-2188-D	86-2281-D
	Front, 4.0L	86-2188-D	86-2281-D
2003	Front, 2.8L	86-2188-D	86-2324-D
	Front, 4.0L	86-2188-D	86-2281-D

YEARS SPECIFICATIONS SIDE INNER OUTER

## Volkswagen (Continued)

### Passat 4 Motion (cont.)

2004	Front, 1.8L	86-2188-D	86-2281-D
	Front, 2.8L	86-2188-D	86-2324-D
	4.0L	86-2188-D	86-2281-D
2005	1.8L	86-2188-D	86-2281-D
	2.8L	86-2188-D	86-2324-D
06-08	Front, 3.6L	86-2421-D	86-2338-D
99-05	Rear	86-1100-D	N/A
06-08	Rear	86-2413-D	86-2375-D

### Passat Syncro

91-92	Front	Left	86-2137-D	86-2232-D
		Right	86-1185-D	86-2232-D
		Rear	86-1084-D	86-1085-D

### Phaeton

04-06	Front, 4.2L	86-2385-D	86-2319-D
	Front, 6.0L	86-2365-D	86-2319-D
05-06	Rear, 4.2L	N/A	86-2362-D

### Quantum (2WD)

82-85	4 Cyl	86-1084-D	86-1085-D
1983	5 Cyl, A/T (To 12/82)	86-1084-D	86-1085-D
83-88	5 Cyl, A/T (From 12/82)		
	Left	86-2137-D	86-1101-D
	Right	86-1184-D	86-1101-D
84-88	5 Cyl, M/T	86-2137-D	86-1101-D

### Quantum Syncro

86-88	Front	86-2137-D	86-1101-D
	Rear	86-1084-D	86-1085-D

### R32 (AWD)

2008	Front	86-2452-D	86-2338-D
	Rear	86-2413-D	N/A

### Rabbit (Incl. Pickup)

75-80		86-1084-D	86-1085-D
81-84		86-1084-D	86-1085-D
2006	A/T	86-2432-D	86-2338-D
	M/T	86-2413-D	86-2375-D
2007	A/T, (To 1K-7-140 000)	86-2432-D	86-2338-D
	A/T, (From 1K-7-140-001)	86-2426-D	86-2338-D
	M/T	86-2413-D	86-2375-D
08-09	A/T	86-2426-D	86-2338-D
	M/T	86-2413-D	86-2338-D

### Scirocco

75-84	A/T, (To 53-F-000-191)	86-1084-D	86-1085-D
	M/T, (To 53-E-040-254)	86-1084-D	86-1085-D
84-87	8V, A/T, (From 53-F-000-192)		
	Left	86-1184-D	86-1101-D
	Right	86-1185-D	86-1101-D
	8V, M/T, (From 53-E-040-255)		
	Left	86-1184-D	86-1101-D
	Right	86-1185-D	86-1101-D
86-88	16V	Left	86-1184-D
		Right	86-1185-D



# C.V. BOOT KITS

YEARS SPECIFICATIONS SIDE INNER OUTER

## Volkswagen (Continued)

### Type III, Fastback, Squareback

thru 68 ... Swing Axle	86-1091-D	N/R
69-on ... IRS	86-1084-D	86-1084-D

### Type IV, 411, 412

71-74 ... Rear	86-1086-D	86-1086-D
----------------	-----------	-----------

### Thing

73-74 ... Rear	86-1086-D	86-1086-D
----------------	-----------	-----------

*Note: The following boot numbers are neoprene boots with three convolutions which replaces thermoplastic boots with five or more convolutions: 86-1085 & 86-1101.*

## Volkswagen SUV/Truck/Van

### Eurovan

93-94	86-1100-D	86-2281-D
95-04	86-1100-D	86-2342-D

### Routan

2009	86-2443-D	N/A
10-12	86-2479-D	N/A

### Tiguan (FWD)

09-13 ... A/T	86-2421-D	86-2338-D
M/T	86-2452-D	86-2338-D

### Tiguan (AWD)

09-13 ... Front	86-2421-D	86-2375-D
Rear	86-2413-D	N/A

### Touareg

04-05	Front, 3.2L	86-2452-D	86-2319-D
	Front, 4.2L	86-2456-D	86-2338-D
	Front, 4.9L	86-2456-D	86-2338-D
2006	Front, 3.2L	86-2452-D	86-2338-D
	Front, 3.6L	86-2452-D	86-2338-D
	Front, 4.2L (To 7L-6-090 000)	86-2456-D	86-2338-D
	Front, 4.2L (From 7L-6-090 001)	86-2452-D	86-2338-D
07-08	Front, 5.0L	86-2456-D	86-2338-D
	Front, 3.6L	86-2452-D	86-2338-D
	Front, 4.2L	86-2456-D	86-2338-D
2009	Front, 5.0L	86-2456-D	86-2338-D
	Front, 3.6L	86-2452-D	86-2338-D
	Front, 4.2L	86-2452-D	86-2338-D
2010	Front 3.0L	86-2452-D	86-2338-D
	Front, 3.6L	86-2452-D	86-2338-D
11-13	Front, 3.0L	86-2452-D	86-2319-D
	Front, 3.6L	86-2452-D	86-2319-D

YEARS SPECIFICATIONS SIDE INNER OUTER

## Volkswagen SUV/Truck/Van

(Continued)

### Transporter, Type II

thru 67 ... Swing Axle	86-1091-D	N/R
68-79 ... IRS	86-1086-D	86-1086-D

### Vanagon

80-91 ... Rear	86-1086-D	86-1086-D
----------------	-----------	-----------

### Vanagon Syncro

86-91 ... Front	86-1086-D	86-2268-D
Rear	86-1086-D	86-1086-D

## Volkswagen (International Model)

### Atlantic

77-87	86-1084-D	86-1085-D
-------	-----------	-----------

### New Beetle

1998 ... 2.0L, A/T	86-2188-D	86-1101-D
98-01 ... 1.8L, 2.0L, M/T	Left	86-2137-D
	Right	86-1185-D
99-01 ... 1.8L, 2.0L, A/T	86-2359-D	86-1101-D

### Caribe

77-87	86-1084-D	86-1085-D
-------	-----------	-----------

### Combi

70-97 ... M/T	86-1086-D	86-1086-D
---------------	-----------	-----------

### Corsair

85-87	86-1084-D	86-1085-D
-------	-----------	-----------

### Derby

95-98 ... M/T	Left	86-2137-D
	Right	86-1185-D
		86-1101-D

### Eurovan

00-04 ... M/T	86-2257-D	86-2337-D
---------------	-----------	-----------

### Golf

87-91	86-1084-D	86-1085-D
92-98 ... 1.8L, 2.0L, A/T	86-2188-D	86-1101-D
92-01 ... 1.8L, 2.0L, M/T	Left	86-2137-D
	Right	86-1185-D
99-01 ... 1.8L, 2.0L, A/T	86-2359-D	86-1101-D

### Jetta

87-91	86-1084-D	86-1085-D
92-98 ... 1.8L, 2.0L, A/T	86-2188-D	86-1101-D
92-01 ... 1.8L, 2.0L, M/T	Left	86-2137-D
	Right	86-1185-D
94-01 ... 2.8L	Left	86-2137-D
	Right	86-1185-D
99-01 ... 1.8L, 2.0L, A/T	86-2359-D	86-1101-D

For racing C.V. related products, Volkswagen, Sand Rail, Off-Road, see pages 213-221.

# C.V. BOOT ILLUSTRATIONS



<p><b>86-1084-D</b></p>	<p><b>86-1085-D</b></p>	<p><b>86-1086-D</b></p>	<p><b>86-1091-D</b></p>	<p><b>86-1100-D</b></p>
<p><b>86-1101-D</b></p>	<p><b>86-1184-D</b></p>	<p><b>86-1185-D</b></p>	<p><b>86-2137-D</b></p>	<p><b>86-2188-D</b></p>
<p><b>86-2232-D</b></p>	<p><b>86-2254-D</b></p>	<p><b>86-2257-D</b></p>	<p><b>86-2268-D</b></p>	<p><b>86-2281-D</b></p>
<p><b>86-2319-D</b></p>	<p><b>86-2324-D</b></p>	<p><b>86-2337-D</b></p>	<p><b>86-2338-D</b></p>	<p><b>86-2342-D</b></p>
<p><b>86-2359-D</b></p>	<p><b>86-2362-D</b></p>	<p><b>86-2365-D</b></p>	<p><b>86-2375-D</b></p>	<p><b>86-2385-D</b></p>
<p><b>86-2389-D</b></p>	<p><b>86-2413-D</b></p>	<p><b>86-2421-D</b></p>	<p><b>86-2422-D</b></p>	<p><b>86-2424-D</b></p>



# C.V. BOOT ILLUSTRATIONS

<b>86-2426-D</b> 	<b>86-2432-D</b> 	<b>86-2443-D</b> 	<b>86-2452-D</b> 	<b>86-2456-D</b> 
<b>86-2479-D</b> 				

## INNER TIE ROD KITS



Inner Tie Rod Kits include one (1) Inner Tie Rod, Nut and Hardware (If applicable). All Inner Tie Rod Kits are packaged in our distinctive EMPI 3-Color Trilingual Box.

MODEL	YEARS	SPECIFICATIONS	LEFT	RIGHT
<b>Volkswagen</b>				
New Beetle	98-01 .....	From Ch. #1C-W-047 125.....	88-4249-K .....	88-4249-K
Golf	85-92 .....	Power, TRW Design.....	88-4087-K .....	88-4087-K
	99-03 .....	(New Body).....	88-4249-K .....	88-4249-K
Jetta	85-92 .....	Power, TRW Design.....	88-4087-K .....	88-4087-K
	99-03 .....	(New Body).....	88-4249-K .....	88-4249-K

## UNIVERSAL RACK & PINION BELLOW KITS



### 88-1000-K (Non-Vented)

This Universal Rack Bellows can be cut to enlarge both the tie rod end and the housing end to fit a wide variety of applications.



### 88-1001-K (Vented)

This Universal Rack Bellows can be cut to enlarge both the tie rod end and the housing end to fit a wide variety of applications.



# RACK & PINION BELLOW KITS



EMPI Rack & Pinion Bellow Kits include Bellow, Plastic Tie Straps and Instructions. All Rack & Pinion Bellow Kits are packaged in our distinctive EMPI 3-Color Trilingual Box.



YEARS SPECIFICATIONS LEFT RIGHT

## Volkswagen

<b>New Beetle</b>			
98-10		88-1590-K	88-1590-K
<b>Cabrio</b>			
95-96		88-1555-K	88-1555-K
97-02		88-1500-K	88-1500-K
<b>Cabriolet</b>			
85-93	Manual	88-1545-K	N/A
	Power	88-1500-K	88-1500-K
<b>CC</b>			
09-10		88-1613-K	88-1613-K
<b>Corrado</b>			
90-95	TRW Design	88-1500-K	88-1500-K
92-95	ZF Design	88-1555-K	88-1555-K
<b>EOS</b>			
07-10		88-1613-K	88-1613-K
<b>Golf (Old Body Style)</b>			
85-92	Manual	88-1545-K	88-1545-K
	Power	88-1500-K	88-1500-K
93-99	TRW Design	88-1500-K	88-1500-K
	ZF Design	88-1555-K	88-1555-K
<b>Golf (New Body Style)</b>			
99-06		88-1590-K	88-1590-K
2010		88-1613-K	88-1613-K
<b>GTi</b>			
2006		88-1590-K	88-1590-K
07-10		88-1613-K	88-1613-K
<b>Jetta (Old Body Style)</b>			
82-84	Manual	88-1545-K	N/A
	Power	88-1500-K	88-1500-K
85-89	Manual	88-1545-K	88-1545-K
	Power	88-1500-K	88-1500-K
90-92	Manual	88-1545-K	88-1545-K
	Power TRW Design	88-1500-K	88-1500-K
	Power ZF Design	88-1555-K	88-1555-K
93-99	TRW Design	88-1500-K	88-1500-K
	ZF Design	88-1555-K	88-1555-K
<b>Jetta (New Body Style)</b>			
99-04		88-1590-K	88-1590-K
2005	To Ch. # 9M-5-149 999	88-1590-K	88-1590-K
	From Ch. # 1K-5-600 001	88-1613-K	88-1613-K
06-10		88-1613-K	88-1613-K

YEARS SPECIFICATIONS LEFT RIGHT

## Volkswagen

<b>Jetta (New Body Style) (cont.)</b>			
90-95	TRW Design	88-1500-K	88-1500-K
	ZF Design	88-1555-K	88-1555-K
96-97		88-1555-K	88-1555-K
98-99	4 Cyl. (To 1/31/99)	88-1574-K	88-1588-K
	6 Cyl. (To 1/31/99, Outer Bellows only)	88-1574-K	88-1574-K
1999	4 Cyl. (From 2/1/99)	88-1610-K	88-1588-K
	6 Cyl. (From 2/1/99)	88-1610-K	88-1610-K
00-05	4 Cyl.	88-1610-K	88-1588-K
	6 Cyl.	88-1610-K	88-1588-K
02-04	8 Cyl.	88-1610-K	88-1588-K
06-10		88-1613-K	88-1613-K
<b>Phaeton</b>			
04-06		88-1635-K	88-1635-K
<b>R32</b>			
2008		88-1613-K	88-1613-K
<b>Rabbit (Includes Convertible and Pickup)</b>			
75-81		88-1545-K	N/A
1982	Manual	88-1545-K	N/A
	Power	88-1500-K	88-1500-K
83-84	Manual	88-1545-K	88-1545-K
	Power	88-1500-K	88-1500-K
06-09		88-1613-K	88-1613-K
<b>Scirocco</b>			
75-81		88-1545-K	N/A
82-88	Manual	88-1545-K	N/A
	Power	88-1500-K	88-1500-K
<b>Volkswagen SUV/Truck/Van</b>			
<b>Eurovan</b>			
93-01		88-1545-K	88-1545-K
<b>Routan</b>			
09-10		88-1640-K	88-1640-K
<b>Tiguan</b>			
09-11		88-1613-K	88-1613-K
<b>Vanagon (Incl. Syncro)</b>			
80-91		88-1545-K	88-1545-K





# TOOLS, GREASE, PAINT

## CV Joint Grease



86-3000/86-3005



86-3009



86-3039 / 86-3027

EMPI Moly C.V. Joint Grease meets the rigid factory fill requirements set by all major C.V. Joint manufacturers. Ask your current supplier if their grease is true moly based! EP-2 (Extreme Pressure) Additive provides superior protection against seizure under extreme pressure loads. Use EMPI Moly Grease for all long travel play car or racing applications.

- 86-3000** Moly Grease for C.V. Joints, 4 oz. packet
- 86-3005** Moly Grease for C.V. Joints, 3 oz. packet
- 86-3009** Red CV Grease, 14oz tube
- 86-3039\*** 400 lb. Plastic Lined Drum of Grease
- 86-3027** 35 lb. Drum of Grease

**\*Shipped via Truck Only**

**Grease CANNOT be shipped via AIR**

## C.V. Bolts



### C.V. BOLTS

- 87-7701** Bolt for Type 1 C.V., M8 x 1 15/16", 12 Pt. Internal, Each (Bulk) (Ref. P/N: 113 501 229D)
- 16-2409** Bolt for Type 1 C.V., M8 x 1 15/16", 12 Pt. Internal, Set of 6
- 16-2410** Bolt for Type 1 & 2 C.V., 3/8" - 24 x 1 3/4", Allen Head, Set of 6
- 16-2412** Bolt for Type 1 & 2 C.V., 3/8" - 24 x 1 3/4", 12 Pt., External, Set of 6
- 16-2413** Bolt for 930 C.V., 3/8" - 24 x 2 1/4", 12 Pt., External, Set of 6
- 16-2415** Bolt for 930 C.V., 3/8" - 24 x 2 5/16", 12 Pt., External, Set of 6 (For P/N: 86-9312 Flange)
- 16-2414** Bolt for 934 C.V., 7/16" - 20 x 2 7/16", 12 Pt., External, Set of 6

### C.V. JOINT BOLT SOCKET

Available for 6-Point and 12-Point 8mm Hex C.V. joint bolts.

- 5796** C.V. Joint 12-Point Hex Socket, 8mm, 3/8" Drive
- 5797** C.V. Joint 6-Point Hex Socket, 8mm, 3/8" Drive

### TORQUE DISTRIBUTION WASHER

- 87-5080** Torque Distribution Washer for 90mm, T-1 Joint, Each
- 87-5081** Torque Distribution Washer for 100mm, T-2 Joint, Each
- 87-5871**  Torque Distribution Washer for 108mm, 930 Joint, Each

# CLUTCH ALIGNMENT TOOLS



This tool makes a complicated job a cinch. When installing the pressure plate, this tool quickly and easily aligns the Pressure Plate and the Clutch Disc, centering on the Pilot Bearing, for quick and error-free installation. Made of High-Impact Plastic with Molded-in Splines and Peg Board Ring, these tools are made to be used again and again. All Clutch Tools are packaged in our distinctive EMPI 3-Color Display Cards. Once out of the package, each tool is easy to identify with molded-in part number and EMPI Blue color.



5302-K

5415-K

5403-K

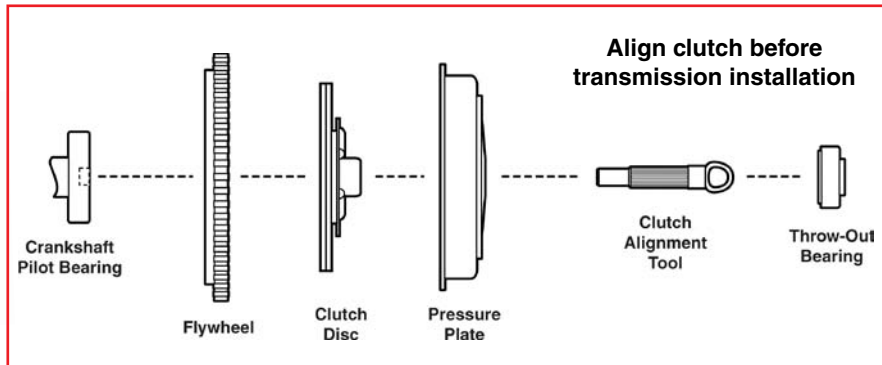

MAKE & MODEL	YEARS	DESCRIPTION	CLUTCH DISC DIA & SPLINE	PILOT BEARING/BUSHING DIAMETER	LENGTH	EMPI #
<b>Volkswagen</b>						
Beetle (New)	98-99	Gas	13/16 x 24	.782	1.070	5403-K+
Beetle, Ghia	49-79	Standard Trans	13/16 x 24	.591	1.085	5302-K
	68-79	Auto Stick Trans	13/16 x 21	.466	.894	5367-K
Cabriolet, Cabrio	85-98	All	13/16 x 24	.669	.705	5378-K+
Corrado, Passat	89-95	All	7/8 x 28	No Pilot	No Pilot	5415-K
Dasher	73-81	Incl. Diesel	13/16 x 24	.591	1.085	5302-K
Fox	87-93	All	13/16 x 24	.591	1.085	5302-K
Golf	85-95	8 Valve, (Incl. Diesel)	7/8 x 28	.669	.705	5378-K+
	86-99	16 Valve, 6 Cyl.	13/16 x 24	.782	1.070	5403-K+
Jetta	80-97	8 Valve	7/8 x 28	.669	.705	5378-K+
	87-99	16 Valve, 6 Cyl.	13/16 x 24	.782	1.070	5403-K+
Quantum, Quantum Synchro	82-85	4 Cyl.	13/16 x 24	.591	1.085	5302-K
Rabbit (Incl. Pickup)	74-84	All	7/8 x 28	.669	.705	5378-K+
Scirocco	74-89	8 Valve	7/8 x 28	.669	.705	5378-K+
	86-89	16 Valve	13/16 x 24	.782	1.070	5403-K+
Type III, Fastback, Squareback	62-73	1.5L, 1.6L	13/16 x 24	.591	1.085	5302-K
	71-74	1.8L	13/16 x 24	.587	1.800	5335-K
Type IV, 411, 412	71-74	All	13/16 x 24	.587	1.800	5335-K

+ Note: Round plate type clutch tool.

## Volkswagen SUV/Truck/Van

Transporter, Type II	50-71	All	13/16 x 24	0.591	1.085	5302-K
	72-79	All	13/16 x 24	0.587	1.800	5335-K
Vanagon	80-92	Exc. Diesel	13/16 x 24	0.587	1.800	5335-K
	82-84	Diesel	13/16 x 24	0.591	1.085	5302-K



# ATV C.V. BOOT KITS

Complete with Boot, Stainless Steel Clamps, Grease and Basic Installation Instructions. EMPI Constant Velocity Boot Kits come packaged in our distinctive 3-Color Trilingual Box.



<b>86-1032-D</b> 	<b>86-1033-D</b> 	<b>86-1038-D</b> 	<b>86-1051-D</b> 	<b>86-1052-D</b> 
<b>86-1188-D</b> 	<b>86-2151-D</b> 	<b>86-2254-D</b> 	<b>86-2284-D</b> 	<b>86-2343-D</b> 
<b>86-2371-D</b> 	<b>86-2411-D</b> 	<b>86-2453-D</b> 	<b>86-2461-D</b> 	<b>86-2464-D</b> 

YEAR SPECIFICATIONS INNER OUTER YEAR SPECIFICATIONS INNER OUTER

## ARCTIC CAT

250							
99-05	Front & <i>Rear</i> .....	86-1188-D....	86-1188-D				
300							
98-05	Front & <i>Rear</i> .....	86-1188-D....	86-1188-D				
375							
2002	Front .....	86-1188-D....	86-1188-D				
400							
98-08	Front .....	86-1188-D....	86-1188-D				
03-08	<i>Rear</i> .....	86-1188-D....	86-1188-D				
<b>Bearcat 454</b>							
96-98	Front, (To Serial # 13000)						
		86-1188-D....	86-2284-D				
1998	Front, (From Serial # 13001)						
		86-1188-D....	86-1188-D				
500							
98-08	Front .....	86-1188-D....	86-1188-D				
03-06	<i>Rear</i> .....	86-1188-D....	86-1188-D				

## ARCTIC CAT (Continued)

650							
04-06	Front & <i>Rear</i> .....	86-1188-D....	86-1188-D				
700							
07-08	Front & <i>Rear</i> .....	86-1188-D....	86-1188-D				

## BOB-CAT

2200							
04-10	4x4.....	86-2411-D....	86-2411-D				
2300							
06-10	4x4.....	86-2411-D....	86-2411-D				

## BOMBARDIER

<b>Outlander 330</b>							
04-05	Front .....	86-2371-D.....	N/A				
	<i>Rear</i> .....	N/A .....	86-2343-D				
<b>Outlander 400</b>							
03-05	Front .....	86-2371-D.....	N/A				
	<i>Rear</i> .....	N/A .....	86-2343-D				

# ATV C.V. BOOT KITS



YEAR SPECIFICATIONS INNER OUTER

## BOMBARDIER (Continued)

**Outlander 650**  
2006 Front ..... N/A ..... 86-2453-D

**Outlander 800**  
2006 Front ..... N/A ..... 86-2453-D

**Quest 500**  
02-04 Front ..... 86-2371-D ..... N/A

**Quest 650**  
02-04 Front ..... 86-2371-D ..... N/A

**Traxter 500**  
99-05 Front ..... 86-2371-D ..... N/A

**Traxter 650**  
2005 Front ..... 86-2371-D ..... N/A

## CAN-AM

**Commander 800**  
11-12 Front ..... N/A ..... 86-2453-D

13-14 Front ..... 86-2453-D ..... TBA

2015 Front ..... N/A ..... 86-2453-D

**Maverick 1000**  
2013 Front ..... N/A ..... 86-2453-D

14-15 Front (Exc. X MR) ..... N/A ..... 86-2453-D

Front, X MR ..... 86-2453-D ..... 86-2453-D

**Outlander 400**  
07-12 Front ..... N/A ..... 86-2453-D

Rear ..... N/A ..... 86-2343-D

13-15 Front ..... N/A ..... 86-2453-D

**Outlander L 450**  
2015 Front ..... N/A ..... 86-2453-D

**Outlander 500**  
07-15 Front ..... N/A ..... 86-2453-D

**Outlander 650**  
07-12 Front ..... N/A ..... 86-2453-D

13-15 Front (Exc. X MR) ..... N/A ..... 86-2453-D

**Outlander 800**  
07-15 Front ..... N/A ..... 86-2453-D

**Renegade 500**  
08-14 Front ..... N/A ..... 86-2453-D

**Renegade 800**  
07-15 Front ..... N/A ..... 86-2453-D

**Renegade 1000**  
12-15 Front ..... N/A ..... 86-2453-D

## CARTER BROTHERS

**GTR 250**  
06-07 Rear ..... N/A ..... 86-1188-D

09-10 Rear ..... N/A ..... 86-1188-D

**GTR 250 Interceptor**  
2008 Rear ..... N/A ..... 86-1188-D

YEAR SPECIFICATIONS INNER OUTER

## CARTER BROTHERS (Continued)

**GTR 300 Interceptor**  
2008 Rear ..... N/A ..... 86-1188-D

## CUB CADET

**Volunteer**  
06-13 Front ..... 86-2411-D ..... 86-2343-D

Rear ..... 86-2411-D ..... 86-2343-D

## HONDA

**TRX 300**  
88-00 4x4 ..... 86-2284-D ..... 86-2284-D

**TRX 350 Rancher**  
00-06 4x4 ..... 86-2371-D ..... 86-2284-D

**TRX 350**  
86-87 4x4 ..... N/A ..... 86-2284-D

**TRX 350D**  
87-89 4x4 ..... N/A ..... 86-2284-D

**FL400R Pilot**  
89-90 Rear ..... 86-1038-D ..... 86-1033-D

**TRX 400 Foreman**  
95-01 4x4 ..... 86-2284-D ..... 86-2284-D

2003 4x4 ..... 86-2371-D ..... 86-2284-D

**TRX 420 Rancher**  
07-11 4x4 ..... 86-2464-D ..... 86-2284-D

**TRX 450 Foreman**  
98-04 4x4 ..... 86-2371-D ..... 86-2284-D

**TRX 500 Foreman**  
05-06 4x4 ..... 86-2461-D ..... 86-1188-D

2007 4x4 Exc. ES w/Power Steering  
86-2461-D ..... 86-1188-D

4x4 ES w/Power Steering  
86-2461-D ..... 86-2284-D

08-13 4x4 ..... 86-2461-D ..... 86-2284-D

**TRX 500 Rubicon**  
01-04 4x4 ..... 86-2371-D ..... 86-1188-D

05-07 4x4 ..... 86-2461-D ..... 86-1188-D

08-13 4x4 ..... 86-2461-D ..... 86-2284-D

**TRX 650 Rincon**  
03-04 Front ..... 86-2371-D ..... 86-1188-D

2005 Front ..... 86-2461-D ..... 86-1188-D

## KAWASAKI

**Bayou 300**  
89-04 4x4 ..... 86-2371-D ..... 86-2284-D

**Bayou 400**  
93-99 4x4 ..... 86-2371-D ..... 86-2284-D



# ATV C.V. BOOT KITS

YEAR	SPECIFICATIONS	INNER	OUTER
<b>KAWASAKI (Continued)</b>			
<b>Brute Force 650</b>			
05-09	4x4.....	86-2461-D....	86-2284-D
06-08	Front, 4x4i.....	86-2461-D....	86-1188-D
	Rear, 4x4i.....	N/A.....	86-1188-D
09-13	Front, 4x4i.....	86-2461-D....	86-2453-D
	Rear, 4x4i.....	86-2461-D....	86-2254-D
<b>Brute Force 750</b>			
05-07	Front.....	86-2461-D....	86-1188-D
	Rear.....	N/A.....	86-1188-D
08-11	Front.....	N/A.....	86-2453-D
	Rear.....	86-2461-D....	86-2254-D
12-13	Front.....	86-2461-D....	86-2453-D
	Rear.....	86-2461-D....	86-2254-D
<b>Mule 610</b>			
05-08	4x4.....	86-2284-D....	86-1188-D
2009	4x4 (To VIN # 1JK1AFE1 9B547191)	86-2284-D....	86-1188-D
	4x4 (From VIN # 1JK1AFE1 9B547192)	86-2461-D....	86-2453-D
10-11	4x4.....	86-2461-D....	86-2453-D
<b>Mule 2010</b>			
1990	4x4.....	N/R.....	86-2284-D
<b>Mule 2510</b>			
93-95	4x4 620cc.....	N/A.....	86-2284-D
97-99	4x4 620cc.....	N/A.....	86-2284-D
2000	4x4 620cc and 950cc Diesel	86-2371-D....	86-2284-D
<b>Mule 3010</b>			
01-08	4x4 620cc and 950cc Diesel	86-2371-D....	86-2284-D
<b>Prairie 300</b>			
99-02	4x4.....	86-2284-D....	86-2284-D
<b>Prairie 360</b>			
03-05	4x4.....	86-2284-D....	86-2284-D
06-08	4x4.....	86-2461-D....	86-2284-D
09-13	4x4.....	86-2461-D....	N/A
<b>Prairie 400</b>			
97-02	4x4.....	86-2284-D....	86-2284-D
<b>Prairie 650</b>			
02-03	4x4.....	86-2284-D....	86-2284-D
<b>Prairie 700</b>			
04-06	.....	86-2461-D....	86-2284-D

## KUBOTA

<b>RTV900</b>			
03-08	Front.....	86-2371-D....	86-2284-D

YEAR	SPECIFICATIONS	INNER	OUTER
<b>KYMCO</b>			
<b>MXU500</b>			
06-07	Front.....	86-2284-D....	86-2284-D

## POLARIS

<b>300</b>			
1995	4x4.....	N/R.....	86-2343-D
<b>350L</b>			
1990	4x4.....	N/R.....	86-2343-D
<b>500</b>			
2002	4x4 PPS.....	86-2461-D....	86-2343-D
<b>Big Boss 250</b>			
1991	6x6.....	N/R.....	86-2343-D
1992	6x6 (BTB).....	N/R.....	86-2343-D
<b>Big Boss 400L</b>			
95-96	6x6 (BTB).....	N/R.....	86-2343-D
1997	6x6.....	N/R.....	86-2343-D
<b>Big Boss 500</b>			
1998	6x6.....	N/R.....	86-2343-D
<b>Diesel 500</b>			
99-02	Front, 4x4.....	N/R.....	86-2343-D
	Rear, 4x4.....	86-2151-D....	86-1052-D
<b>Hawkeye</b>			
06-07	4x4 Front.....	86-2284-D....	86-2284-D
06-09	Rear.....	86-2284-D....	86-2284-D
<b>Magnum 325</b>			
2000	4x4.....	N/A.....	86-2343-D
01-02	4x4 (Exc HDS).....	N/A.....	86-2343-D
	4x4 HDS.....	86-2461-D....	86-2343-D
<b>Magnum 330</b>			
03-04	4x4 HDS.....	86-2461-D....	86-2343-D
<b>Magnum 425</b>			
95-96	4x4 (BTB).....	N/R.....	86-2343-D
	6x6 (BTB).....	N/R.....	86-2343-D
1997	4x4.....	N/R.....	86-2343-D
	6x6.....	N/R.....	86-2343-D
1998	4x4.....	N/R.....	86-2343-D
<b>Magnum 500</b>			
99-00	4x4.....	N/R.....	86-2343-D
2001	4x4 (Exc. HDS).....	N/R.....	86-2343-D
2002	4x4 HDS.....	86-2461-D....	86-2343-D
2003	4x4.....	86-2461-D....	86-2343-D
<b>PTV</b>			
2002	4x4.....	86-2461-D....	86-2343-D
<b>Ranger 500</b>			
04-05	Front, 4x4.....	N/A.....	86-2343-D
<b>Scrambler 400</b>			
95-96	4x4 (BTB).....	N/R.....	86-2343-D
97-98	4x4.....	N/R.....	86-2343-D
1999	4x4 (BTB).....	N/R.....	86-2343-D

# ATV C.V. BOOT KITS



YEAR	SPECIFICATIONS	INNER	OUTER
<b>POLARIS (Continued)</b>			
<b>Scrambler 500</b>			
97-98	4x4.....	N/R.....	86-2343-D
<b>Sportsman 300</b>			
08-10	Front, 4x4.....	86-2284-D....	86-2284-D
	Rear, 4x4.....	86-2284-D....	86-2284-D
<b>Sportsman 335</b>			
99-00	Front, 4x4.....	N/R.....	86-2343-D
2000	Rear, 4x4 (CV Design) ....	86-1051-D....	86-1052-D
<b>Sportsman 400</b>			
95-96	Front, 4x4 (BTB).....	N/R.....	86-2343-D
1997	Front 4x4.....	N/R.....	86-2343-D
2001	Front, 4x4.....	N/R.....	86-2343-D
	Rear, 4x4.....	86-2151-D....	86-1052-D
02-05	Rear, 4x4.....	86-2151-D....	86-1052-D
08-10	Front, 4x4.....	86-2284-D....	86-2284-D
	Rear, 4x4.....	86-2284-D....	86-2284-D
<b>Sportsman 450</b>			
06-07	Front, 4x4 (Before 7/25/06)....	N/A.....	86-2343-D
<b>Sportsman 500</b>			
1996	4x4 (BTB).....	N/R.....	86-2343-D
98-99	Front, 4x4.....	N/R.....	86-2343-D
1999	Rear, 4x4.....	86-2151-D....	86-1052-D
00-01	Front, 4x4.....	N/R.....	86-2343-D
	Front, 6x6.....	N/R.....	86-2343-D
	Rear, 4x4.....	86-2151-D....	86-1052-D
02-05	Rear, 4x4.....	86-2151-D....	86-1052-D
2006	Front, 4x4.....	N/R.....	86-2343-D
2007	Front, 4x4 (Before 7/25/06)....	N/A.....	86-2343-D
<b>Sportsman 600</b>			
03-05	Rear, 4x4.....	86-2151-D....	86-1032-D
<b>Sportsman 700</b>			
02-05	Rear, 4x4.....	86-2151-D....	86-1032-D
06-07	Front, 4x4 (Before 7/25/06)....	N/A.....	86-2343-D
<b>Sportsman 800</b>			
2005	Rear, 4x4.....	N/A.....	86-1032-D
2006	Front, 4x4 (Housing Stamped GKN)	N/A.....	86-2343-D
2007	Front, 4x4 (Before 7/25/06)....	N/A.....	86-2343-D
<b>Trail Boss 250</b>			
1991	Front, 4x4.....	N/R.....	86-2343-D
1992	Front, 4x4 (BTB).....	N/R.....	86-2343-D
<b>Trail Boss 350L</b>			
1991	Front, 4x4.....	N/R.....	86-2343-D
1992	Front, 4x4 (BTB).....	N/R.....	86-2343-D
<b>Worker 335</b>			
1999	Front, 4x4.....	N/R.....	86-2343-D

YEAR	SPECIFICATIONS	INNER	OUTER
<b>POLARIS (Continued)</b>			
<b>Worker 500</b>			
1999	Front, 4x4.....	N/R.....	86-2343-D
	Rear, 4x4.....	86-2151-D....	86-1052-D
<b>Xpedition 325</b>			
00-02	Front, 4x4.....	N/R.....	86-2343-D
<b>Xpedition 425</b>			
00-01	Front, 4x4.....	N/R.....	86-2343-D
<b>Xplorer 300</b>			
96-99	Front, 4x4.....	N/R.....	86-2343-D
<b>Xplorer 400</b>			
95-96	4x4 (BTB).....	N/R.....	86-2343-D
97-98	4x4.....	N/R.....	86-2343-D
<b>SUZUKI</b>			
<b>Eiger 400</b>			
2002	Front, 4x4.....	86-2284-D....	86-2284-D
03-04	Front, 4x4, W/ 68LAC O.B. Housing	86-2284-D....	86-2284-D
	Front, 4x4, W/ UJ68 O.B. Housing	86-2461-D....	86-2461-D
05-07	Front, 4x4.....	86-2461-D....	86-2284-D
<b>King Quad 300</b>			
91-93	4x4.....	N/A.....	86-2284-D
96-98	4x4, W/ 68LAC I.B. Housing	86-2284-D....	86-2284-D
	4x4, W/ 71LAC I.B. Housing ..	N/A.....	86-2284-D
99-02	4x4.....	86-2284-D....	86-2284-D
<b>King Quad 400</b>			
08-11	4x4.....	86-2461-D....	86-2284-D
<b>King Quad 450</b>			
07-10	Front, 4x4.....	86-2284-D....	86-2284-D
	Rear, 4x4.....	86-2284-D....	86-2284-D
<b>Quad Master 500</b>			
00-01	4x4.....	86-2284-D....	86-2284-D
<b>Quad Runner 250</b>			
1987	4x4.....	N/R.....	86-2284-D
88-96	4x4.....	N/A.....	86-2284-D
97-98	4x4, W/ 68LAC I.B. Housing	86-2284-D....	86-2284-D
	4x4, W/ 71LAC I.B. Housing ..	N/A.....	86-2284-D
99-02	4x4.....	86-2284-D....	86-2284-D
<b>Quad Runner 500</b>			
98-01	4x4.....	86-2284-D....	86-2284-D
<b>Q.U.V. 620</b>			
2005	4x4.....	86-2371-D....	86-2284-D
<b>Twin Peaks 700</b>			
04-05	4x4.....	86-2461-D....	86-2284-D



# ATV C.V. BOOT KITS

YEAR SPECIFICATIONS INNER OUTER

## SUZUKI (Continued)

### Vinson 500

2002	4x4, A/T	86-2284-D	86-2284-D
03-05	4x4	86-2461-D	86-2461-D
2006	4x4	86-2461-D	86-2284-D

## YAMAHA

### Big Bear 350

87-96	4x4	86-2371-D	86-2284-D
1997	4x4, W/ 68 AC I.B. Housing	86-2371-D	86-2284-D
	4x4, W/68 LAC I.B. Housing	86-2284-D	86-2284-D
98-99	4x4	86-2284-D	86-2284-D

### Big Bear 400

00-01	4x4	86-2284-D	86-2284-D
02-06	4x4	86-2371-D	86-2284-D
07-12	4x4 (Front)	86-2461-D	86-2284-D
	4x4 (Rear, IRS)	86-2284-D	86-2284-D

### Bruin 350

04-06	4x4	86-2371-D	86-2284-D
-------	-----	-----------	-----------

### Grizzly 350

2007	4x4	86-2371-D	86-2284-D
07-11	Front, 4x4 (Exc. IRS)	86-2371-D	86-2284-D
	Front, 4x4, (IRS)	86-2461-D	86-2284-D
	Rear, 4x4, (IRS)	86-2284-D	86-2284-D
12-14	Front, 4x4	86-2461-D	86-2284-D

### Grizzly 400

2007	Front, 4x4	86-2371-D	86-2284-D
	Rear, 4x4	86-2284-D	86-2284-D

### Grizzly 450

07-14	Front, 4x4	86-2461-D	86-2284-D
	Rear, 4x4	86-2284-D	86-2284-D

### Grizzly 600

98-01	4x4	86-2284-D	86-2284-D
-------	-----	-----------	-----------

YEAR SPECIFICATIONS INNER OUTER

## YAMAHA (Continued)

### Grizzly 660

2002	Front, 4x4	86-2284-D	86-2284-D
	Rear, 4x4	86-2284-D	86-2284-D
2003	Front, 4x4, W/ 68 LAC O.B. Housing	86-2461-D	86-2284-D
	Front, 4x4, W/ UJ 68 O.B. Housing	86-2461-D	86-2461-D
	Rear, 4x4	86-2284-D	86-2461-D
04-08	Front, 4x4	86-2461-D	86-2284-D
	Rear, 4x4	86-2284-D	86-2284-D

### Kodiak 400

93-06	Front, 4x4	86-2371-D	86-2284-D
05-06	Rear, 4x4	86-2371-D	86-2284-D

### Kodiak 450

03-06	Front, 4x4	86-2284-D	86-2284-D
05-06	Rear, 4x4	86-2284-D	86-2284-D

### Rhino 450

06-09	Front, 4x4	86-2461-D	86-1188-D
	Rear, 4x4	86-2284-D	86-1188-D

### Rhino 660

2004	Front, 4x4	86-2284-D	86-2284-D
	Rear, 4x4	86-2284-D	86-2284-D
05-07	Front, 4x4	86-2461-D	86-1188-D
	Rear, 4x4	86-2284-D	86-1188-D

### Rhino 700

08-13	Front, 4x4	86-2284-D	TBA
	Rear, 4x4	86-2284-D	TBA

### Timberwolf 250

94-00	4x4	86-2371-D	86-2284-D
-------	-----	-----------	-----------

### Wolverine 350

95-05	4x4	86-2284-D	86-2284-D
-------	-----	-----------	-----------

### Wolverine 450

06-10	4x4	86-2371-D	86-2284-D
-------	-----	-----------	-----------



## CHROMOLY COMPLETE AXLES FOR RHINO

Be it mountain trails, sand, or off road, these axles and joints are for the owner who likes to have serious fun with his equipment. These units have 4340 chromoly outer housing (outboard end only), cages, inner races, and axle bars. They will take the punishment and not leave you stranded. All Axles are supplied with the spindle nut.

**CHROMOLY**

### Rhino Extended Length Axles

Note: Must be used with aftermarket long travel 6" extended trailing arms. **EXCLUDES EXTENDED WHEELBASE SETUPS.**

- 80-9124-0 Chromoly Axle Assembly, Rhino 04-07, Left Front, Extended Length, Each
- 80-9125-0 Chromoly Axle Assembly, Rhino 04-07, Right Front, Extended Length, Each
- 80-9127-0 Chromoly Axle Assembly, Rhino 04-07, Right Rear, Extended Length, Each

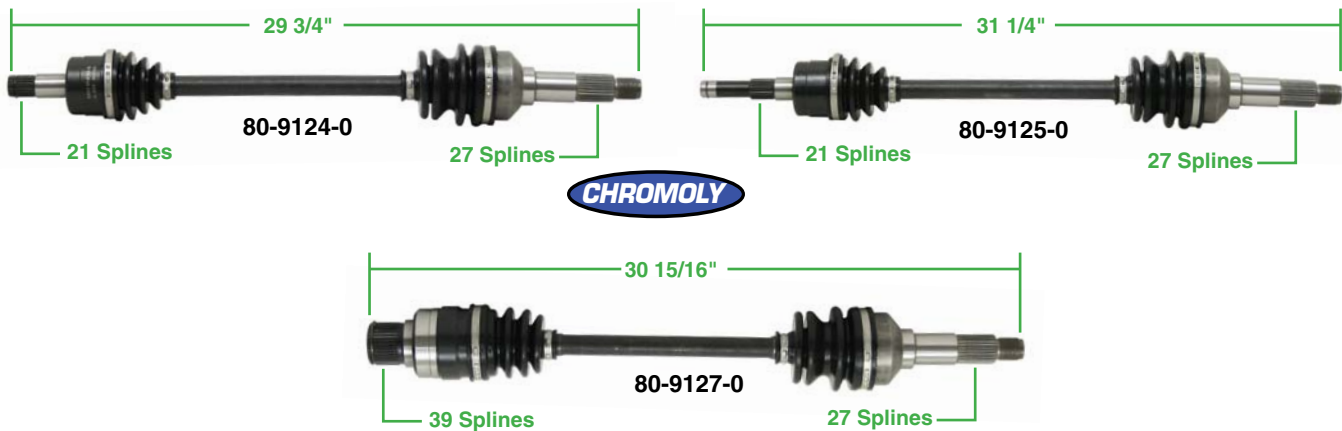

**CHROMOLY**

\*All axle lengths are measured collapsed

**CHROMOLY**

### Rhino OEM Length Axles

- 80-9130-0 Chromoly Axle Assembly, Rhino 04-07, Left Front, OEM Length, Each
- 80-9131-0 Chromoly Axle Assembly, Rhino 04-07, Right Front, OEM Length, Each
- 80-9133-0 Chromoly Axle Assembly, Rhino 04-07, Right Rear, OEM Length, Each

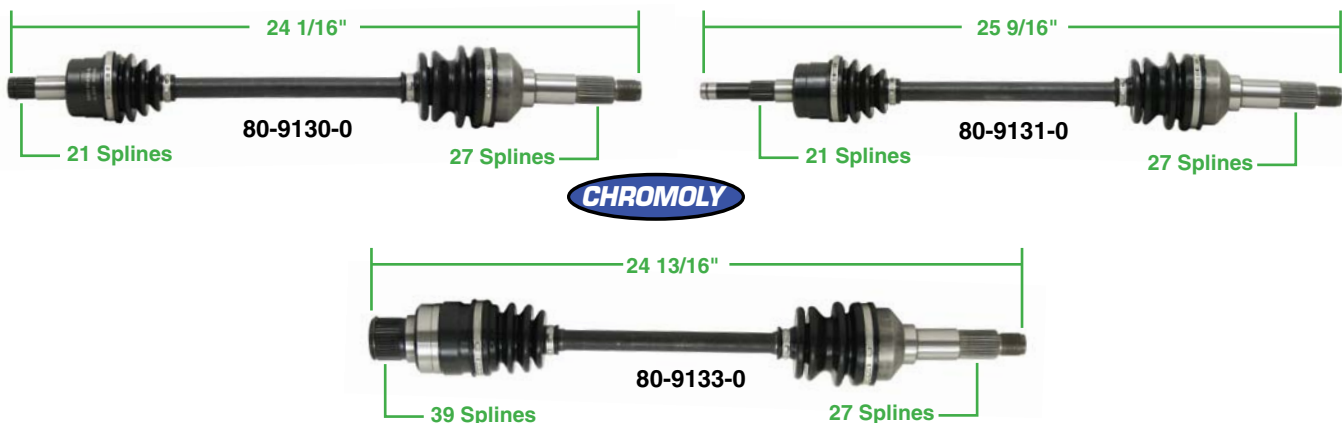

**CHROMOLY**

\*All axle lengths are measured collapsed





## REPLACEMENT CV JOINTS FOR RHINO

These CV Joints are engineered for replacement on either OEM or EMPI produced axles. O.B. Joint (87-6793-R) is 100% chromoly. I.B. Joints have chromoly inner races and cages, making these CV Joints much stronger than OEM. As an added feature these CV Joints are 100% compatible with OEM center bars.

- 87-6789-R HP CV Joint, Rhino \*04-07, Front Axle, Inboard End, Driver Side
- 87-6790-R HP CV Joint, Rhino \*04-07, Front Axle, Inboard End, Passenger Side
- 87-6792-R HP CV Joint, Rhino \*04-07, Rear Axle, Inboard End, Passenger Side
- 87-6793-R HP CV Joint, Rhino \*04-07, Outboard End, All (Supplied with Nut)

*\*Late 04 (2nd Design)*



## REPLACEMENT CV BOOT KITS FOR RHINO

Complete with Boot, Stainless Steel Clamps, Grease, and Installation Instructions. EMPI Replacement CV Boot Kits for Rhino come packaged in our distinctive 3-Color Trilingual Box.

- 86-2461-D Inner Front, Left & Right
- 86-2284-D Inner Rear, Left & Right
- 86-1188-D Outer Front & Rear, Left & Right



## SUZUKI SAMURAI CHROMOLY CV JOINTS AND AXLE BARS

The Suzuki Samurai has quite an off road following and deserves quality components. Our 4340 Chromoly CV Joints and Axles will get the job done. An improved design over OE, these axles and joints must be used together.

- 87-9923-R**                      Chromoly CV Joint, Samurai, Suzuki, 86-95, Each  
25 Splines on Bar End (Inner Race)
- 87-3168-0**                      **Clip** to hold O.B. CV Joint to Bar (10 pcs.)
- 81-1065-R**                      Chromoly Axle Bar, Samurai, Suzuki, 86-95, Short, Left, Each  
25 Splines on Joint End, 26 Splines on Transmission End,  
14.875" Long
- 81-1066-R**                      Chromoly Axle Bar, Samurai, Suzuki, 86-95, Long, Right, Each  
25 Splines on Joint End, 26 Splines on Transmission End,  
27.687" Long



## TOYOTA TRUCK AND LAND CRUISER CHROMOLY CV JOINTS AND AXLE BARS (STOCK 27 SPLINE)

4340 Chromoly CV Joints and Axles. Manufactured for OE 27 spline. An improved design over OE. 87-9314-R Joint can be used with OE axle bars or EMPI axle bars. See specifications listed below.

- 87-9314-R**                      Toyota 27 Spline Chromoly CV Joint, Land Cruiser (FJ40) 75-84,  
Land Cruiser (FJ60) 8/80-1/90, Truck 79-85, Each
- 87-3043-0**                      **Clip** to hold O.B. CV Joint to Bar (10 pcs.)
- 87-8604-R**                      27 Spline H/P Chromoly Axle Bar, Land Cruiser (FJ60) 8/80-1/90,  
Truck 79-85, 31.5" Long, Driver Side, Each
- 87-8605-R**                      27 Spline H/P Chromoly Axle Bar, Truck 79-85, 15.25" Long,  
Pass. Side, Each
- 87-1264-R**                      27 Spline H/P Chromoly Axle Bar, Land Cruiser (FJ40) 75-84,  
28.937" Long, Driver Side, Each
- 87-1265-R**                      27 Spline H/P Chromoly Axle Bar, Land Cruiser (FJ40) 75-84,  
Land Cruiser (FJ60) 8/80-1/90, 17.312" Long, Pass. Side, Each



## TOYOTA TRUCK AND LAND CRUISER CHROMOLY CV JOINTS AND AXLE BARS (30 SPLINE)

























4340 Chromoly CV Joints and Axles. Manufactured for 30 spline aftermarket applications. An improved design over OE. 30 spline Joint **must use EMPI axle bars**. See specifications listed below.

- 87-6766-R**                      30 Spline Chromoly CV Joint, Land Cruiser (FJ40) 75-84,  
Land Cruiser (FJ60) 8/80-1/90, Truck 79-85, Each
- 87-3043-0**                      **Clip** to hold O.B. CV Joint to Bar (10 pcs.)
- 87-1266-R**                      30 Spline H/P Chromoly Axle Bar, Land Cruiser (FJ60) 8/80-1/90,  
Truck 79-85, 31.5" Long, Driver Side, Each
- 87-1267-R**                      30 Spline H/P Chromoly Axle Bar, Truck 79-85, 15.25" Long,  
Pass. Side, Each
- 81-1071-R**                      30 Spline H/P Chromoly Axle Bar, Land Cruiser (FJ40) 75-84,  
28.937" Long, Driver Side, Each
- 81-1072-R**                      30 Spline H/P Chromoly Axle Bar, Land Cruiser (FJ40) 75-84,  
Land Cruiser (FJ60) 8/80-1/90, 17.312" Long, Pass. Side, Each





# REPLACEMENT PARTS

<p><b>237 011 031</b> <b>98-0109-B</b> Scissor Jack Type 2 &amp; Type 1, Each</p> 	<p><b>113 101 221B</b> <b>98-0142-B</b> Deflector Plate, Gasket Generator Support, Type 1 60-79, Ghia 60-74, Type 2 63-71, Type 3 64-73, Each</p> 	<p><b>043 101 457</b> <b>98-0144-B</b> Hex Nut, Cylinder Head (8mm), Type 1 All, Ghia All, Type 3 All, Each</p> 
<p><b>251 012 243</b> <b>98-0113-B •</b> O.E.M. Type Hub Cap Tool, Type 1 50-79, Ghia 56-74, Type 2 50-79, Type 3 64-73, Each</p> 	<p><b>042 101 355CH</b> <b>98-1345-B</b> High Performance, <b>Bare</b> Cylinder Head for 85.5mm <b>See Page 27 for All Variations</b></p> 	<p><b>111 101 461</b> <b>98-0145-B</b> Washer, Cylinder Head (10mm), Type 1 All, Ghia All, Type 2 All, Type 3 All, Each</p> 
<p><b>043 101 025</b> <b>043 101 033</b> <b>043 101 102A</b> <b>98-0431-B</b> Engine Case, 1500-1600cc, Type 1 67-79, Ghia 67-74, Type 2 66-71, Type 3 66-73 AS41 Version</p> <p><b>Magnesium Alloy</b></p> 	<p><b>043 101 355C</b> <b>98-1355-B</b> Stock Dual Port Cyl. Head, <b>Bare</b>, 1500-1600cc, Type 1 71-79, Ghia 71-74, Type 2 71, Type 3 71-73 Cast 040.101.375.13</p> 	<p><b>043 101 465</b> <b>98-0146-B</b> Washer, Cylinder Head (8mm), Type 1 All, Ghia All, Type 3 All, Each</p> 
<p><b>111 101 123</b> <b>98-0133-B •</b> Dowel Pin, Main Bearing, Type 1 All, Ghia All, Type 2 50-71, Type 3 All, Each</p> 	<p><b>043 101 355CK</b> <b>98-1356-B</b> Stock Dual Port Cyl. Head, Complete, Type 1 71-79, Ghia 71-74, Type 2 71, Type 3 71-73 Cast 040.101.375.13</p> 	<p><b>021 101 481</b> <b>98-0148-B •</b> Valve Cover Gasket, 1700-2000cc, Each, Type 2 72-79, Vanagon 80-83, Each</p> 
<p><b>040 101 157</b> <b>98-0157-B •</b> Cam Plug, Rubber, for O.E.M. Case w/o Groove, Type 1 66-79, Ghia 66-74, Type 2 63-71, Type 3 64-73, Each</p>  <p><b>(New Tooling)</b></p>	<p><b>98-1324-B</b> Dual Port <b>Bare</b> Cylinder Head for 85.5mm. 12mm 3/4" Reach Plug</p> 	<p><b>113 101 481F</b> <b>00-9907-B •</b> Valve Cover Gasket, 1200-1600cc, Each, Type 1 61-79, Ghia 61-74, Type 2 61-71, Type 3 64-73, Each</p> 
<p><b>113 101 157C</b> <b>98-0156-B •</b> Cam Plug, Metal, for Case w/ Groove, 1300-1600cc, Type 1 66-79, Ghia 66-74, Type 2 63-71, Type 3 64-73, Each</p> 	<p><b>98-1325-B</b> Dual Port Complete Cylinder Head for 85.5mm. 12mm 3/4" Reach Plug</p> 	<p><b>043 105 101</b> <b>98-1510-B</b> Crank Shaft, 69mm, 1500-1600cc, Type 1 67-79, Ghia 67-74, Type 2 63-71, Type 3 64-73</p> 
<p><b>113 101 211G</b> <b>00-9194-B •</b> Gen./Alt. Stand, 12-Volt Type 1 67-74, Ghia 67-74, Type 2 67-71, Each</p> 	<p><b>113 101 401BR</b> <b>00-4002-0</b> Valve Guide, Int/Exh., Type 1 61-74, Ghia 61-74, Type 2 61-71, Type 3 64-73, Each</p> 	<p><b>113 105 209</b> <b>98-1520-B</b> Timing Gear, 1200-1600cc, Type 1 61-79, Ghia 61-74, Type 2 61-71, Type 3 64-73, Each</p> 
<p><b>113 101 219</b> <b>98-0141-B</b> Gasket, Generator Stand Type 1 60-79, Ghia 60-74, Type 2 61-71, Type 3 64-73, Each</p> 	<p><b>021 101 457</b> <b>98-0143-B</b> Hex Nut, Cylinder Head (10mm), Type 1 All, Ghia All, Type 2 All, Type 3 All, Each</p> 	<p><b>111 105 213</b> <b>98-1521-B</b> Woodruff Key, Timing Gear, Type 1 61-79, Ghia 61-74, Type 2 61-71, Type 3 64-73, Each</p> 

(•) Also available in skinpack **467**

# REPLACEMENT PARTS

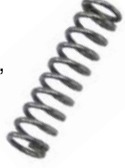

<p><b>113 105 219</b> <b>98-1522-B</b> Spacer Ring for Crankshaft, 1200-1600cc, Type 1 50-79, Ghia 56-74, Type 2 50-71, Type 3 64-73, Each</p> 	<p><b>113 105 245FG</b> <b>32-1546-B •</b> Flywheel Seal, 1200-1600cc, Red Silicone, Type 1 61-79, Ghia 61-74, Type 2 61-71, Type 3 67-73, Each <b>(Elring)</b></p> 	<p><b>113 105 289A</b> <b>98-1281-B</b> Flywheel Shim (.36mm), Type 1 66-79, Ghia 67-74, Type 2 64-71, Type 3 64-73, Each</p> 
<p><b>111 105 223</b> <b>98-1523-B</b> Distributor Drive Gear, Type 1 61-79, Ghia 61-74, Type 2 61-71, Type 3 64-73, Each</p> 	<p><b>113 105 245FS</b> <b>32-1545-B •</b> Flywheel Seal, 1200-1600cc, Red Silicone, Type 1 61-79, Ghia 61-74, Type 2 61-71, Type 3 67-73, Each</p> 	<p><b>113 105 291A</b> <b>98-1282-B</b> Flywheel Shim (.38mm), Type 1 66-79, Ghia 67-74, Type 2 64-71, Type 3 64-73, Each</p> 
<p><b>111 105 227</b> <b>98-1527-B</b> Retaining Clip, Type 1 61-79, Ghia 61-74, Type 2 61-71, Type 3 64-73, Each</p> 	<p><b>113 105 249</b> <b>98-1549-B</b> Woodruff Key, Crank Pulley, Type 1 61-79, Ghia 61-74, Type 2 61-71, Type 3 64-73, Each</p> 	<p><b>311 105 295A</b> <b>98-1283-B</b> O-Ring, Flywheel, Type 1 66-79, Ghia 67-74, Type 2 64-71, Type 3 64-73, Each</p> 
<p><b>113 105 231B</b> <b>98-1531-B</b> Distributor Drive Pinion, Type 1 61-79, Ghia 61-74, Type 2 61-71, Type 3 64-73, Each</p> 	<p><b>311 105 273A</b> <b>98-1273-B</b> Flywheel, w/4 Dowel, 200mm/12-Volt/130 Teeth 1300-1600cc, Type 1 66-79, Ghia 67-74, Type 2 64-71, Type 3 64-73</p> 	<p><b>111 105 297</b> <b>00-4030-B •</b> H.D. Gland Nut Washer, All 40HP 1200-1600cc</p> 
<p><b>111 105 233</b> <b>98-0115-B</b> Distributor Drive Pinion Spring, Type 1 61-79, Ghia 61-74, Type 2 61-71, Type 3 64-73, Each</p> 	<p><b>311 105 273HP</b> <b>98-1275-B</b> Flywheel w/8 Dowel &amp; Lightened, 200mm/130 Teeth, Type 1 66-79, Ghia 67-74, Type 2 64-71, Type 3 64-73</p> 	<p><b>111 105 305E</b> <b>00-4029-B •</b> Flywheel Gland Nut, 1200-1600cc w/4 Speed Trans., Type 1 61-79, Ghia 61-74, Type 2 61-71, Type 3 64-73</p> 
<p><b>111 105 235A</b> <b>98-1532-B</b> Washer, Distributor Drive Pinion (.60mm), Type 1 50-79, Ghia 56-74, Type 2 50-71, Type 3 64-73, Each</p> 	<p><b>113 105 281A</b> <b>98-1277-B</b> Flywheel Shim (.24mm), Type 1 66-79, Ghia 67-74, Type 2 64-71, Type 3 64-73, Each</p> 	<p><b>311 105 401B</b> <b>98-0153-B</b> Connecting Rod Set, New, Set of 4, Type 1 66-79, Ghia 66-74, Type 2 63-71, Type 3 64-73</p>  <p><b>NEW! NOT REBUILT</b></p>
<p><b>113 105 241A</b> <b>98-1541-B</b> Oil Slinger, Type 1 61-79, Ghia 61-74, Type 2 61-71, Type 3 64-73, Each</p> 	<p><b>113 105 283A</b> <b>98-1278-B</b> Flywheel Shim (.30mm), Type 1 66-79, Ghia 67-74, Type 2 64-71, Type 3 64-73, Each</p> 	<p><b>311 105 431A</b> <b>98-1570-B</b> Connecting Rod Bushing Set, Split Type, 1300-1600cc, Type 1 66-79, Ghia 66-74, Type 2 63-71, Type 3 64-73</p>  <p><b>MAHLE</b></p>
<p><b>029 105 245B</b> <b>98-0150-B</b> Flywheel Seal, 1700-2000cc, Type 2 72-79, Vanagon 80-83, Each</p> 	<p><b>113 105 287A</b> <b>98-1280-B</b> Flywheel Shim (.34mm), Type 1 66-79, Ghia 67-74, Type 2 64-71, Type 3 64-73, Each</p> 	<p><b>039 105 701MX</b> <b>98-1582-S</b> Rod Bearing Set, Standard, 2000cc, Type 4</p>  <p><b>Silverline</b> ENGINE BEARINGS</p>



# REPLACEMENT PARTS

<p><b>113 105 701</b> <b>98-1575-B</b> Rod Bearing Set, Std., 1200-1600cc, Type 1 61-79, Ghia 61-74, Type 2 61-71, Type 3 64-73</p>  <p><b>MAHLE</b></p>	<p><b>113 109 021G</b> <b>98-1921-B</b> Camshaft, Stock Grind, w/Dish Gear, Type 1 71-79, Ghia 71-74, Type 2 71, Type 3 71-73</p> 	<p><b>311 109 601</b> <b>98-1935-B •</b> S/S Intake Valve, 35.5mm, w/ 8mm Stem 1500-1600cc, Type 1 67-74, Ghia 67-74, Type 2 65-71, Type 3 64-73, Each</p> 
<p><b>039 105 707MX</b> <b>98-1584-S</b> Rod Bearing Set, .25mm, 2000cc, Type 4</p>  <p><b>Silverline</b> ENGINE BEARINGS</p>	<p><b>311 109 301A</b> <b>00-4033-7 •</b> Push Rod, 1300-1600cc, Type 1 66-79, Ghia 66-74, Type 2 63-71, Type 3 64-73, Each</p> 	<p><b>113 109 612A</b> <b>98-1932-B •</b> S/S Exhaust Valve, 32mm, w/ 8mm Stem 1500-1600cc, Type 1 67-74, Ghia 67-74, Type 2 65-71, Type 3 64-73, Each</p> 
<p><b>113 105 707</b> <b>98-1577-B</b> Rod Bearing Set, .25mm, 1200-1600cc, Type 1 61-79, Ghia 61-74, Type 2 61-71, Type 3 64-73</p>  <p><b>MAHLE</b></p>	<p><b>113 109 309C</b> <b>21-4300-B •</b> Cam Follower, Solid, 1200-1600cc (Box of 8), Type 1 61-79, Ghia 61-74, Type 2 61-71, Type 3 64-73</p> 	<p><b>113 109 623C</b> <b>98-1923-B</b> Valve Spring, 1200-1600cc, Type 1 61-79, Ghia 61-74, Type 2 61-71, Type 3 64-73, Each 80lbs. at 1.550" installed height, Free Length 2.065"</p> 
<p><b>039 105 713MX</b> <b>98-1585-S</b> Rod Bearing Set, .50mm, 2000cc, Type 4</p>  <p><b>Silverline</b> ENGINE BEARINGS</p>	<p><b>311 109 335</b> <b>00-8522-1</b> Push Rod Tube, 1300-1600cc, Type 1 66-79, Ghia 66-74, Type 2 63-71, Type 3 64-73, Each</p> 	<p><b>113 109 641B</b> <b>98-1964-B</b> Valve Spring Retainer, Type 1 61-79, Ghia 61-74, Type 2 61-71, Type 3 64-73, Each</p> 
<p><b>113 105 713</b> <b>98-1571-B</b> Rod Bearing Set, .50mm, 1200-1600cc, Type 1 61-79, Ghia 61-74, Type 2 61-71, Type 3 64-73</p>  <p><b>MAHLE</b></p>	<p><b>311 109 335ADJ</b> <b>00-9160-B •</b> Adjustable Push Rod Tube, Nylon, Type 1 61-79, Ghia 61-74, Type 2 61-71, Type 3 64-73, Each</p> 	<p><b>113 109 651A</b> <b>00-4044-B •</b> Valve Spring Seat Keeper, Type 1 61-79, Ghia 61-74, Type 2 61-71, Type 3 64-73, Each</p> 
<p><b>039 105 719MX</b> <b>98-1586-S</b> Rod Bearing Set, .75mm, 2000cc, Type 4</p>  <p><b>Silverline</b> ENGINE BEARINGS</p>	<p><b>113 109 345A</b> <b>00-9150-B •</b> Push Rod Tube Seal (Bag of 100), Type 1 61-79, Ghia 61-74, Type 2 61-71, Type 3 64-73</p> 	<p><b>111 115 107AHP</b> <b>98-1158-B</b> Oil Pump, 8mm Bolt Holes, 30mm Gears, 1500-1600cc, Type 1 67-70, Ghia 67-70, Type 2 67-70, Type 3 67-70</p> 
<p><b>113 105 719</b> <b>98-1579-B</b> Rod Bearing Set, .75mm, 1200-1600cc, Type 1 61-79, Ghia 61-74, Type 2 61-71, Type 3 64-73</p>  <p><b>MAHLE</b></p>	<p><b>113 109 345AS</b> <b>00-9153-B •</b> Push Rod Tube Seal, High Temp. <b>Silicone</b> (Bag of 100), Type 1 61-79, Ghia 61-74, Type 2 61-71, Type 3 64-73</p> 	<p><b>111 115 107BHD</b> <b>98-1159-B</b> Oil Pump, 8mm Bolt Holes, 30mm Gears, 1600-2100cc, Type 1 71-79, Ghia 71-74, Type 2 71-80, Vanagon 81-92, Type 3 71-73</p> 
<p><b>113 109 021D</b> <b>98-1920-B</b> Camshaft, Stock Grind, w/Flat Gear, Type 1 66-70, Ghia 66-70, Type 2 63-70, Type 3 64-70</p> 	<p><b>043 109 451</b> <b>98-0114-B •</b> M8 x 1.0 Valve Adjustment Screw, Type 1 50-79, Ghia 56-74, Type 2 50-71, Type 3 64-73, Each</p> 	<p><b>111 115 111B</b> <b>98-1164-B</b> Gasket, Oil Pump Body (8mm), Type 1 67-79, Ghia 67-74, Type 2 67-71, Type 3 67-73, Each</p> 

(•) Also available in skinpack **469**

# REPLACEMENT PARTS























<p><b>111 115 131B</b> <b>98-1166-B</b> Gasket, Oil Pump Cover (8mm), Type 1 67-79, Ghia 67-74, Type 2 67-71, Type 3 67-73, Each</p> 	<p><b>113 115 349T</b> <b>98-1171-B •</b> Block-Off Plate, Dipstick Hole with 1/8" NPT Hole</p> 	<p><b>111 117 151</b> <b>98-1179-B</b> Seal, Oil Cooler (For Cooler w/8mm Ports), Each, Type 1 50-70, Ghia 56-70, Type 2 50-70, Each</p> 
<p><b>311 115 141C</b> <b>00-9148-5 •</b> Oil Pump Cover Only, Stock Style</p> 	<p><b>113 115 475</b> <b>98-1173-B</b> Sealing Washer, Oil Filler to Gen / Alt Pedestal, Type 1 61-74, Ghia 61-74, Type 2 61-71, Type 3 64-73, Each</p> 	<p><b>021 117 151A</b> <b>00-9256-B •</b> Oil Cooler Seal, 10mm (Bag of 100), Type 1 71-79, Ghia 71-74, Type 2 71-79, Vanagon 80-83</p> 
<p><b>113 115 175</b> <b>00-9923-B •</b> Oil Strainer, 1200cc (40HP), 61-65</p> <p><i>14mm Dia.*</i></p>  <p><small>*Measurement is at the base of the collar where it joins the oil pick-up tube.</small></p>	<p><b>111 115 485</b> <b>00-8968-7 •</b> Chrome Stock Style Oil Filler Cap</p> 	<p><b>111 117 151B</b> <b>00-9255-B •</b> Oil Cooler Seal, 8mm/10mm (Bag of 100), Type 1 50-70, Ghia 56-70, Type 2 50-70</p> 
<p><b>311 115 175A</b> <b>98-1160-B •</b> Oil Strainer, 1300-1600cc, 62-69 Single Relief Case</p> <p><i>16mm Dia.*</i></p>  <p><small>*Measurement is at the base of the collar where it joins the oil pick-up tube.</small></p>	<p><b>111 115 491</b> <b>98-1175-B</b> Seal, Oil Filler Tube, Type 1 50-74, Ghia 56-74, Type 2 50-71, Each</p> 	<p><b>113 117 303</b> <b>00-8894-0 •</b> Doghouse Oil Cooler to Case Adapter, for 98-1161-B only, Skin Packed</p> 
<p><b>111 115 175B</b> <b>00-9924-B •</b> Oil Strainer, 1600cc, 70-79 Dual Relief Case</p> <p><i>19mm Dia.*</i></p>  <p><small>*Measurement is at the base of the collar where it joins the oil pick-up tube.</small></p>	<p><b>113 115 611</b> <b>98-1162-B</b> Oil Dipstick, Each, Type 1 61-79, Ghia 61-74, Type 2 61-71</p> 	<p><b>7X0 119 031</b> <b>98-2004-B •</b> Cooling Fan, 34.7mm Inner Fan Dia, 36.9mm Outer Fan Dia, Type 1 71-79, Ghia 71-74, Type 2 71, Each</p> 
<p><b>113 115 181ACR</b> <b>00-8911-B •</b> Chrome Oil Strainer Cover 1200-1600cc, Type 1 61-79, Ghia 61-74, Type 2 61-71, Type 3 64-73</p> 	<p><b>113 117 021</b> <b>98-1161-B</b> <u>Aluminum</u> Oil Cooler, Type 1 71-79, Ghia 71-74, Type 2 71</p> 	<p><b>021 119 245</b> <b>98-9610-B •</b> Dip Stick Boot, Universal, Each</p> 
<p><b>113 115 193</b> <b>00-8856-B •</b> Magnetic Oil Drain Plug w/ Washer, Chrome, Type 1 61-79, Ghia 61-74, Type 2 61-71, Type 3 64-73</p> 	<p><b>021 117 021B</b> <b>17-2806-0</b> <u>Aluminum</u> Oil Cooler, Type 2/4, 1700-2000cc / 914, 7 Plate</p> 	<p><b>113 119 303B/4G</b> <b>00-8867-9 (5 Pair)</b> Single Port Cylinder Covers (Pair), Type 1 66-70, Ghia 66-70, Type 2 63-70, Type 3 64-70, Pair</p> 
<p><b>113 115 349</b> <b>98-1170-B •</b> Block-Off Plate, Dipstick Hole, Type 3</p> 	<p><b>111 117 021E</b> <b>98-1178-B</b> <u>Aluminum</u> Oil Cooler, Type 1 50-70, Ghia 56-70, Type 2 50-70</p> 	<p><b>113 119 303J/4H</b> <b>00-8990-9 (5 Pair)</b> Dual Port Cylinder Covers (Pair), Type 1 71-79, Ghia 71-74, Type 2 71, Type 3 71-73, Pair</p> 

**470** (•) Also available in skinpack

**EMPI • BUGPACK • MR. BUG • TREUHAFT • AUTO HAUS**



# REPLACEMENT PARTS

<p><b>043-119-317A</b> <b>98-9984-B</b> Cylinder Deflector Tin, For 8mm Studs, Cad Plated 1500-1600cc</p> 	<p><b>113 127 025BCH</b> <b>98-1270-B •</b> <b>Chrome</b> Fuel Pump, 1200-1600cc, w/Generator</p> 	<p><b>113 129 027E</b> <b>98-1288-B</b> EMPI Carburetor, 30 PICT-1, w/12-Volt Choke <b>SCORE APPROVED</b> Gasket &amp; Studs Included</p> 
<p><b>311-119-317A</b> <b>98-9983-B</b> Cylinder Deflector Tin, For 10mm Studs, Cad Plated 1500-1600cc</p> 	<p><b>113 127 025G</b> <b>98-2079-B •</b> Fuel Pump, 1600cc w/ Alternator, Type 1 74-75, Ghia 74</p> 	<p><b>113 129 027H</b> <b>98-1225-B</b> 30/31 PICT-3 Carburetor with Adapter and Hardware</p> 
<p><b>113 119 451D</b> <b>00-8877-B •</b> Black Cool Tin Cylinder Cover, For 8mm studs Type 1 66-79, Ghia 66-74, Type 2 63-71, Type 3 64-73, Each</p> 	<p><b>113 127 303</b> <b>98-2080-B •</b> Fuel Pump Spacer, 1200-1600cc, Type 1 61-74, Ghia 61-74, Type 2 61-71, Type 3 64-67</p> 	<p><b>113 129 029A</b> <b>98-1292-B</b> Carburetor, 31 PICT-3, 12-Volt, 1300-1500cc, Brosol, Type 1 68-70, Ghia 68-70, Type 2 68-70</p> 
<p><b>113 119 517R</b> <b>00-8951-0</b> Front Engine Tin, Type 1 66-70, Ghia 66-70, Type 2 63-70</p> 	<p><b>113 127 307</b> <b>98-1180-B</b> Push Rod, Fuel Pump, (108mm), Type 1 61-73, Type 2 61-71, Type 3 62-67, Ghia 61-73</p> 	<p><b>113 129 031KE</b> <b>98-1289-B</b> EMPI Carburetor, 34 PICT-3, 12-Volt, 1600cc, Type 1 71-74, Ghia 71-74, Type 2 71 (Will clear alternator on late model applications) Gasket &amp; Studs Included</p> 
<p><b>113 119 517S</b> <b>00-8952-0</b> Front Engine Tin, Type 1 71-74, Ghia 71-74, Type 2 71</p> 	<p><b>113 127 307A</b> <b>98-1181-B</b> Push Rod, Fuel Pump w/Alt, (100mm), Type 1 73-74, Ghia 73-74, Each</p> 	<p><b>113 129 034 Kit</b> <b>98-1293-B •</b> Adapter Kit, 30/31 PICT to 34 PICT Intake Manifold, Type 1 61-74, Ghia 61-74, Type 2 61-71 <b>SCORE APPROVED</b></p> 
<p><b>043 119 527</b> <b>00-8938-0</b> Rear Engine Tin, Type 1 66-79, Ghia 66-74, Type 2 63-71</p> 	<p><b>113 127 311</b> <b>98-1182-B</b> Gasket, Fuel Pump Flange Mounting, Type 1 61-74, Ghia 61-74, Type 2 61-71, Type 3 64-67, Each</p> 	<p><b>028 129 087A</b> <b>00-3705-0</b> Fresh Air Hose, <b>Aluminum</b>, 50 x 1000mm, Black, Type 1 61-79, Ghia 61-74, Type 2 61-71, Each</p> 
<p><b>113 119 533L</b> <b>00-8935-B •</b> Rear Engine Tin, Under Pulley, Type 1 61-79, Ghia 61-74, Type 2 61-71</p> 	<p><b>113 127 313</b> <b>98-1183-B</b> Gasket, Fuel Pump Mounting, Type 1 61-74, Ghia 61-74, Type 2, 61-71, Type 3 64-67, Each</p> 	<p><b>028 129 087AL</b> <b>00-3378-0</b> Fresh Air Hose, <b>Aluminum</b>, 50 x 1000mm, Type 1 61-79, Ghia 61-74, Type 2 61-71, Each</p> 
<p><b>113 127 025BCD</b> <b>98-1271-B •</b> Fuel Pump, 1200-1600cc w/Generator, Type 1 61-73, Ghia 61-73, Type 2 61-71, Type 3 64-67</p> 	<p><b>113 127 521A</b> <b>98-1184-B</b> Fuel Line, 26" Type 1, Ghia 66-74, Type 2 66-74, Type 3 63-71</p> 	<p><b>113 129 191G</b> <b>98-1305-B</b> Choke Unit (12-Volt), Type 1 67-73, Ghia 67-73, Type 2 67-71 Fits 30/31/34 EMPI, Brosol, Bocar and Solex Carbs.</p> 

(•) Also available in skinpack **471**

# REPLACEMENT PARTS







<p><b>049 129 412C</b> <b>98-1297-B</b> Air Cut-off By-pass Valve, w/Plunger for 031k Carb., Type 1 71-74, Ghia 71-74, Type 2 71 Fits 34-3, 34-4 and 34 PDSIT 2/3 Carbs.</p> 	<p><b>113 129 729BB</b> <b>00-9960-B</b> Intake Manifold Boot, Split Type, Type 1 71-74, Ghia 71-74, Type 2 71, Each</p> 	<p><b>311 141 025ECH</b> <b>32-1242-B</b> Replacement Pressure Plate, 200mm, thru 70</p> 
<p><b>175 129 650</b> <b>00-9525-B •</b> 8mm Copper Nut (Bag of 100), Type 1 All, Ghia All, Type 2 All, Vanagon All, Type 3 All</p> 	<p><b>113 129 729BS</b> <b>00-3404-B</b> Red Intake Manifold Boot, Type 1 71-74, Ghia 71-74, Type 2 71, Each</p> 	<p><b>311 141 025CK</b> <b>32-1257-B</b> Clutch Kit, 200mm, Type 1 71-79, Ghia 71-74, Type 3 71-73 <b>Sachs Pressure Plate</b></p> 
<p><b>113 129 701AQ</b> <b>17-2805-0 •</b> Intake Manifold, 30 Pict-1, 31 Pict-3, or 34 Pict-3</p> 	<p><b>311 129 777</b> <b>00-3171-7</b> Barrel Nut, Carburetor, Type 1 65-74, Ghia 65-74, Type 2 65-71, Each</p> 	<p><b>211 141 025DBR</b> <b>32-1234-B</b> Clutch Cover, 180mm 9 Spring H.D., Type 1 thru 66, Ghia 56-66, Type 2 thru 63 <b>SACHS</b></p> 
<p><b>113 129 701K</b> <b>98-1311-B</b> Intake Manifold, Single Port, 1500-1600cc, 30mm Base, Type 1 66-70, Ghia 66-70, Type 2 64-70</p> 	<p><b>113 129 881A</b> <b>98-1313-B</b> Spring, Throttle Return, Type 1 65-74, Ghia 65-74, Type 2 65-71, Each</p> 	<p><b>211 141 025DK</b> <b>32-1256-B</b> Clutch Kit, 180mm, Type 1 thru 66, Ghia 56-66, Type 2 thru 63 <b>Sachs Pressure Plate</b></p> 
<p><b>113 129 707A</b> <b>00-3253-7 •</b> 34 PICT 3 Base Gasket, Each</p> 	<p><b>043 129 893</b> <b>98-1002-B •</b> Throttle Tube, Type 1 61-79, Ghia 61-74, Type 2 61-71, Each</p> 	<p><b>311 141 025EBR</b> <b>32-1235-B</b> Clutch Cover, 200mm, 1500-1600cc, Type 1 67-70, Ghia 67-70, Type 2 64-70, Type 3 64-70 <b>SACHS</b></p> 
<p><b>113 129 710D/9G Pair</b> <b>00-3238-0 •</b> Stock Style Dual Port End Kit, Type 1, 2 &amp; 3, Skin Packed <b>NEW! NOT REBUILT</b></p> 	<p><b>311 141 025CBR</b> <b>32-1236-B</b> Clutch Cover, 200mm, 1600cc, Type 1 71-79, Ghia 71-74, Type 2 71, Type 3 71-73 <b>SACHS</b></p> 	<p><b>311 141 025EK</b> <b>32-1258-B</b> Clutch Kit, 200mm, Type 1 67-70, Ghia 67-70, Type 2 61-70 <b>Sachs Pressure Plate</b></p> 
<p><b>113 129 717A</b> <b>98-9987-B</b> Dual Port Metal Gasket, Stock Style, Each</p> 	<p><b>311 141 025CCH</b> <b>32-1243-B</b> Replacement Pressure Plate, 200mm, 71 &amp; Later</p> 	<p><b>311 141 031BK</b> <b>32-1245-B •</b> Clutch Disc, 200mm Rigid Hub, 1500-1600cc, Type 1 67-79, Ghia 67-74, Type 2 64-71, Type 3 64-73</p> 
<p><b>113 129 729B</b> <b>00-3231-B</b> Intake Manifold Boot, 1600cc, Type 1 71-74, Ghia 71-74, Type 2 71, Each</p> 	<p><b>211 141 025DCH</b> <b>32-1241-B</b> Replacement Pressure Plate, 180mm</p> 	<p><b>311 141 031DK</b> <b>32-1250-B •</b> Clutch Disc, 200mm w/ Spring Hub, 1500-1600cc, Type 1 67-79, Ghia 67-74, Type 2 64-71, Type 3 64-73</p> 



















































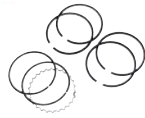



# REPLACEMENT PARTS

<p><b>111 141 031EK</b> <b>32-1240-B •</b> Clutch Disc, 180mm, 1200cc, Type 1 thru 66, Ghia 56-66, Type 2 thru 63</p> 	<p><b>113 141 701CHD</b> <b>98-2011-B •</b> H.D. Release Bearing Operating Shaft, Type 1 &amp; 3 61-70, Type 2 thru 67</p>  <p><b>See page 185 for all shafts</b></p>	<p><b>111 198 007AF</b> <b>00-9900-B •</b> Engine Gasket Set, 1300-1600cc, Type 1 66-79, Ghia 66-74, Type 2 63-71, Type 3 thru 73</p> 
<p><b>111 141 165A</b> <b>32-1205-B •</b> Clutch Release Bearing, 1200-1600cc, Type 1 thru 70, Ghia 56-70, Type 2 thru 70, Type 3 64-70</p> 	<p><b>113 141 701E</b> <b>98-1417-B •</b> H.D. Release Bearing Operating Shaft, Type 1 71-72, Ghia 71-72, Type 3 71-72</p>  <p><b>See page 185 for all shafts</b></p>	<p><b>111 198 007AFG</b> <b>00-9901-B •</b> Engine Gasket Set, 1300-1600cc, Type 1 66-79, Ghia 66-74, Type 2 63-71, Type 3 thru 73 (Elring)</p> 
<p><b>113 141 165B</b> <b>32-1210-B •</b> Clutch Release Bearing, 1600cc, Type 1 71-79, Ghia 71-74, Type 2 71-79, Vanagon 80-91, Type 3 71-73</p> 	<p><b>113 141 701F</b> <b>98-1410-B •</b> Release Bearing Operating Shaft, Type 1 73 &amp; Later</p>  <p><b>See page 185 for all shafts</b></p>	<p><b>029 198 009</b> <b>98-1977-B •</b> Engine Gasket Set, 2.0L, Type 4 72-79 (Elring)</p> 
<p><b>111 141 177AS</b> <b>32-1208-B •</b> Release Bearing Ret. Clip, H.D., Type 1 thru 70, Ghia 56-70, Type 2 thru 70, Type 3 64-70, Each</p> 	<p><b>131 141 719HD</b> <b>16-9908-7 •</b> Clutch Cable Arm, Type I 61-71 and all 002 Type II Transmission, Each</p> 	<p><b>113 198 026</b> <b>98-1088-B •</b> Operating Shaft Bushing Kit, Type 1 61-72, Ghia 61-72, Type 2 61-67, Type 3 thru 72</p> 
<p><b>113 141 181B</b> <b>98-1420-B</b> Guide Sleeve, Clutch Release Bearing, Type 1 71-79, Ghia 71-74, Type 2 71-79, Type 3 71-73</p> 	<p><b>361 141 719HD</b> <b>16-9909-7 •</b> Clutch Cable Arm, Type I 76-79 and all 091 Type II Transmission, Each</p> 	<p><b>113 198 031</b> <b>00-9909-B •</b> Oil Change Gasket Set, Each, Type 1 61-79, Type 1 Ghia 61-74, Type 2 61-71, Type 3 64-73, Each</p> 
<p><b>002 141 701</b> <b>98-1411-B •</b> H.D. Release Bearing Operating Shaft, Type 2 68-70</p>  <p><b>See page 185 for all shafts</b></p>	<p><b>113 141 723</b> <b>98-1421-B</b> Spring, Clutch Operating Lever, Type 1 61-71, Ghia 61-71, Type 2 61-75, Type 3 64-73, Each (35mm Spring I.D.)</p> 	<p><b>043 198 035DP Chromoly</b> <b>00-4020-0 •</b> Chromoly, 8mm Case Stud Kit, Dual Port, Type 1 71-79, Ghia 71-74, Type 2 71, Type 3 71-73, Set</p> 
<p><b>002 141 701A</b> <b>98-1412-B •</b> Release Bearing Operating Shaft, Type 2 71-75</p>  <p><b>See page 185 for all shafts</b></p>	<p><b>113 141 723C</b> <b>98-1422-B</b> Spring, Clutch Operating Lever, Type 1 71-74, Ghia 71-74, Each (40mm Spring I.D.)</p> 	<p><b>043 198 035SP</b> <b>00-4005-0 •</b> Stock Length 8mm Chromoly Case Stud Kit, for Single Port Heads, Skin Packed</p> 
<p><b>091 141 701C</b> <b>98-1414-B •</b> Release Bearing Operating Shaft, Type 2 76 &amp; Later</p>  <p><b>See page 185 for all shafts</b></p>	<p><b>113 141 723D</b> <b>98-1423-B</b> Spring, Clutch Operating Lever, Type 1 74-79, Each (1.470" Spring I.D.)</p> 	<p><b>111 198 123A</b> <b>00-8898-0 •</b> Fan Hardware Kit (Zinc Plated), Skin Packed</p> 

(•) Also available in skinpack **473**

































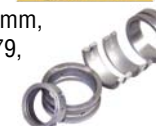













# REPLACEMENT PARTS



<p><b>311 198 069F</b> <b>98-1969-B</b> Piston &amp; Cyl. Set, 85.5mm, 1500-1600cc w/ Cast Piston, Type 1 67-79, Ghia 67-74, Type 2 63-71, Type 3 64-73</p>  	<p><b>198940</b> <b>98-1994-B</b> Piston &amp; Cyl. Set, 94mm x 69mm Stroke, Forged, Type 1 67-79, Ghia 67-74, Type 2 63-71, Type 3 64-73</p>  	<p><b>311 198 16990</b> <b>98-1190-B</b> Piston Ring Set, 90.5mm 1.5 x 2.0 x 4.0mm</p>  
<p><b>198860</b> <b>98-1985-B</b> Piston &amp; Cyl. Set, 85.5mm, 1500-1600cc, Forged, Type 1 67-79, Ghia 67-74, Type 2 63-71, Type 3 64-73</p>  	<p><b>198950</b> <b>98-1995-B</b> Piston &amp; Cyl. Set, 94mm x 82mm Stroke, Forged, Type 1 67-79, Ghia 67-74, Type 2 63-71, Type 3 64-73</p>  	<p><b>311 198 16991</b> <b>98-1191-B</b> Piston Ring Set, 90.5mm 2 x 2 x 4.8mm</p>  
<p><b>198861</b> <b>98-1986-B</b> Piston &amp; Cyl. Set, 87mm x 69mm, Cast, Type 1 67-79, Ghia 67-74, Type 2 63-71, Type 3 64-73</p>  	<p><b>111 198 157A</b> <b>98-1148-B</b> Piston Ring Set, 77mm 2.5 x 2.5 x 4.0mm</p>   	<p><b>311 198 16992</b> <b>98-1192-B</b> Piston Ring Set, 92mm 1.5 x 2.0 x 4.0mm</p>  
<p><b>198870</b> <b>98-1987-B</b> Piston &amp; Cyl. Set, 87mm, 1500-1600cc, Forged, Type 1 67-79, Ghia 67-74, Type 2 63-71, Type 3 64-73</p>  	<p><b>111 198 157B</b> <b>98-1147-B</b> Piston Ring Set, 77mm 2 x 2 x 4.0mm</p>   	<p><b>311 198 16994</b> <b>98-1194-B</b> Piston Ring Set, 94mm 1.2 x 2.0 x 4.0mm</p>  
<p><b>198900</b> <b>98-1990-B</b> Piston &amp; Cyl. Set, 90.5mm x 69mm Stroke, Forged, Type 1 67-79, Ghia 67-74, Type 2 63-71, Type 3 64-73</p>  	<p><b>315 198 163</b> <b>98-1149-B</b> Piston Ring Set, 83mm 2 x 2 x 4.0mm</p>   	<p><b>311 198 16995</b> <b>98-1195-B</b> Piston Ring Set, 94mm 2 x 2 x 4.0mm</p>  
<p><b>198910</b> <b>98-1991-B</b> Piston &amp; Cyl. Set, 90.5mm x 82mm Stroke, Forged, Type 1 67-79, Ghia 67-74, Type 2 63-71, Type 3 64-73</p>  	<p><b>311 198 169A</b> <b>98-1169-B</b> Piston Ring Set, 85.5mm, 2.0 x 2.0 x 5.0mm, 1600cc, Type 1 70-79, Ghia 70-74, Type 2 70-71, Type 3 66-73</p>  	<p><b>025 198 461</b> <b>98-1459-A</b> Main Bearing Set, Std./Std., Vanagon 83-85</p>  
<p><b>198920</b> <b>98-1992-B</b> Piston &amp; Cyl. Set, 92mm x 69mm Stroke, Forged, Type 1 67-79, Ghia 67-74, Type 2 63-71, Type 3 64-73</p>  	<p><b>311 198 16987</b> <b>98-1187-B</b> Piston Ring Set, 87mm 2.0 x 2.0 x 5.0mm</p>  	<p><b>111 198 461</b> <b>98-1461-A</b> Main Brg. Set, Std./Std., 1200-1600cc, Type 1 61-79, Ghia 61-74, Type 2 61-71, Type 3 thru 73</p>  
<p><b>198930</b> <b>98-1993-B</b> Piston &amp; Cyl. Set, 92mm x 82mm Stroke, Forged, Type 1 67-79, Ghia 67-74, Type 2 63-71, Type 3 64-73</p>  	<p><b>311 198 16988</b> <b>98-1188-B</b> Piston Ring Set, 88mm 1.5 x 1.5 x 5.0mm</p>  	<p><b>111 198 461MX</b> <b>98-1461-S</b> Main Brg. Set, Std./Std., 1200-1600cc, Type 1 61-79, Ghia 61-74, Type 2 61-71, Type 3 thru 73</p>  



# REPLACEMENT PARTS

<p><b>111 198 463</b> <b>98-1463-A</b> Main Brg. Set, Std./25mm, 1200-1600cc, Type 1 61-79, Ghia 61-74, Type 2 61-71, Type 3 thru 73</p>  	<p><b>111 198 4710SMX</b> <b>98-1710-S</b> Main Brg. Set, .50mm/Std/ 1.00mm, 1200-1600cc, Type 1 61-79, Ghia 61-74, Type 2 61-71, Type 3 thru 73</p>  	<p><b>111 198 4750SMX</b> <b>98-1750-S</b> Main Brg. Set, .50mm/.50mm/ 1.00mm, 1200-1600cc, Type 1 61-79, Ghia 61-74, Type 2 61-71, Type 3 thru 73</p>  
<p><b>111 198 463MX</b> <b>98-1463-S</b> Main Brg. Set, Std./25mm, 1200-1600cc, Type 1 61-79, Ghia 61-74, Type 2 61-71, Type 3 thru 73</p>  	<p><b>111 198 471 02</b> <b>98-1712-A</b> Main Brg. Set, .50mm/Std./ 2.00mm, 1200-1600cc, Type 1 61-79, Ghia 61-74, Type 2 61-71, Type 3 thru 73</p>  	<p><b>111 198 475 02MX</b> <b>98-1590-S</b> Main Brg. Set, .50mm/.50mm/2.00mm, 1200-1600cc</p>  
<p><b>111 198 465</b> <b>98-1465-A</b> Main Brg. Set, Std./50mm, 1200-1600cc, Type 1 61-79, Ghia 61-74 Type 2 61-71, Type 3 thru 73</p>  	<p><b>111 198 471 02MX</b> <b>98-1712-S</b> Main Brg. Set, .50mm/Std./ 2.00mm, 1200-1600cc, Type 1 61-79, Ghia 61-74, Type 2 61-71, Type 3 thru 73</p>  	<p><b>111 198 477</b> <b>98-1477-A</b> Main Brg. Set, .50mm/.75mm, 1200-1600cc, Type 1 61-79, Ghia 61-74, Type 2 61-71, Type 3 thru 73</p>  
<p><b>111 198 465MX</b> <b>98-1465-S</b> Main Brg. Set, Std./50mm, 1200-1600cc, Type 1 61-79, Ghia 61-74 Type 2 61-71, Type 3 thru 73</p>  	<p><b>111 198 473MX</b> <b>98-1473-S</b> Main Brg. Set, .50mm/.25mm, 1200-1600cc, Type 1 61-79, Ghia 61-74, Type 2 61-71, Type 3 thru 73</p>  	<p><b>111 198 477MX</b> <b>98-1477-S</b> Main Brg. Set, .50mm/.75mm, 1200-1600cc, Type 1 61-79, Ghia 61-74, Type 2 61-71, Type 3 thru 73</p>  
<p><b>111 198 467</b> <b>98-1467-A</b> Main Brg. Set, Std./75mm, 1200-1600cc, Type 1 61-79, Ghia 61-74, Type 2 61-71, Type 3 thru 73</p>  	<p><b>111 198 4730SMX</b> <b>98-1740-S</b> Main Brg. Set, .50mm/.25mm/1.00mm, 1200-1600cc</p>  	<p><b>111 198 4770S</b> <b>98-1770-A</b> Main Brg. Set, .50mm/.75mm/ 1.00mm, 1200-1600cc, Type 1 61-79, Ghia 61-74, Type 2 61-71, Type 3 thru 73</p>  
<p><b>111 198 467MX</b> <b>98-1467-S</b> Main Brg. Set, Std./75mm, 1200-1600cc, Type 1 61-79, Ghia 61-74, Type 2 61-71, Type 3 thru 73</p>  	<p><b>111 198 473 02MX</b> <b>98-1589-S</b> Main Brg. Set, .50mm/.25mm/2.00mm, 1200-1600cc</p>  	<p><b>111 198 4770SMX</b> <b>98-1770-S</b> Main Brg. Set, .50mm/.75mm/ 1.00mm, 1200-1600cc, Type 1 61-79, Ghia 61-74, Type 2 61-71, Type 3 thru 73</p>  
<p><b>111 198 471MX</b> <b>98-1471-S</b> Main Brg. Set, .50mm/Std., 1200-1600cc</p>  	<p><b>111 198 475</b> <b>98-1475-A</b> Main Brg. Set, .50mm/.50mm, 1200-1600cc, Type 1 61-79, Ghia 61-74, Type 2 61-71, Type 3 thru 73</p>  	<p><b>111 198 477 02MX</b> <b>98-1591-S</b> Main Brg. Set, .50mm/.75mm/2.00mm, 1200-1600cc</p>  
<p><b>111 198 4710S</b> <b>98-1710-A</b> Main Brg. Set, .50mm/Std/ 1.00mm, 1200-1600cc, Type 1 61-79, Ghia 61-74, Type 2 61-71, Type 3 thru 73</p>  	<p><b>111 198 475MX</b> <b>98-1475-S</b> Main Brg. Set, .50mm/.50mm, 1200-1600cc, Type 1 61-79, Ghia 61-74, Type 2 61-71, Type 3 thru 73</p>  	<p><b>111 198 479</b> <b>98-1479-A</b> Main Brg. Set, .50mm/1.00mm, 1200-1600cc, Type 1 61-79, Ghia 61-74, Type 2 61-71, Type 3 thru 73</p>  

(•) Also available in skinpack **475**







# REPLACEMENT PARTS



<p><b>111 198 479MX</b> <b>98-1479-S</b> Main Brg. Set, .50mm/1.00mm, 1200-1600cc, Type 1 61-79, Ghia 61-74, Type 2 61-71, Type 3 thru 73</p>  	<p><b>021 198 483AMX</b> <b>98-1452-S</b> Main Brg. Set, Std./25mm, 1.7-2.0L Type 4</p>  	<p><b>111 198 485 02MX</b> <b>98-1852-S</b> Main Brg. Set, 1.00mm/.50mm/2.00mm, 1200-1600cc</p>  
<p><b>021 198 481AMX</b> <b>98-1451-S</b> Main Brg. Set, Std./Std., 1.7-2.0L Type 4</p>  	<p><b>111 198 483MX</b> <b>98-1483-S</b> Main Brg. Set, 1.00mm/.25mm, 1200-1600cc, Type 1 61-79, Ghia 61-74, Type 2 61-71, Type 3 thru 73</p>  	<p><b>111 198 487MX</b> <b>98-1587-S</b> Main Brg. Set, 1.00mm/.75mm, 1200-1600cc</p>  
<p><b>111 198 481MX</b> <b>98-1481-S</b> Main Brg. Set, 1.00mm/Std., 1200-1600cc, Type 1 61-79, Ghia 61-74, Type 2 61-71, Type 3 thru 73</p>  	<p><b>111 198 4830SMX</b> <b>98-1830-S</b> Main Brg. Set, 1.00mm/.25mm/1.00mm, 1200-1600cc</p>  	<p><b>111 198 4870SMX</b> <b>98-1588-S</b> Main Brg. Set, 1.00mm/.75mm/1.00mm, 1200-1600cc</p>  
<p><b>111 198 4810S</b> <b>98-1810-A</b> Main Brg. Set, 1.00mm/ Std/1.00mm, 1200-1600cc, Type 1 61-79, Ghia 61-74, Type 2 61-71, Type 3 thru 73</p>  	<p><b>111 198 483 02MX</b> <b>98-1832-S</b> Main Brg. Set, 1.00mm/.25mm/2.00mm, 1200-1600cc</p>  	<p><b>111 198 487 02MX</b> <b>98-1592-S</b> Main Brg. Set, 1.00mm/.75mm/2.00mm, 1200-1600cc</p>  
<p><b>111 198 4810SMX</b> <b>98-1810-S</b> Main Brg. Set, 1.00mm/ Std/1.00mm, 1200-1600cc, Type 1 61-79, Ghia 61-74, Type 2 61-71, Type 3 thru 73</p>  	<p><b>111 198 485</b> <b>98-1485-A</b> Main Brg. Set, 1.00mm/.50mm, 1200-1600cc, Type 1 61-79, Ghia 61-74, Type 2 61-71, Type 3 thru 73</p>  	<p><b>111 198 491 60</b> <b>98-1496-A</b> Main Brg. Set, 1.50mm/ Std./2.00mm, 1200-1600cc, Type 1 61-79, Ghia 61-74, Type 2 61-71, Type 3 thru 73</p>  
<p><b>111 198 481 02</b> <b>98-1812-A</b> Main Brg. Set, 1.00mm/ Std./2.00mm, 1200-1600cc, Type 1 61-79, Ghia 61-74, Type 2 61-71, Type 3 thru 73</p>  	<p><b>021 198 485AMX</b> <b>98-1593-S</b> Main Brg. Set, Std./25mm, 1.7-2.0L Type 4</p>  	<p><b>111 198 491 60MX</b> <b>98-1496-S</b> Main Brg. Set, 1.50mm/ Std./2.00mm, 1200-1600cc, Type 1 61-79, Ghia 61-74, Type 2 61-71, Type 3 thru 73</p>  
<p><b>111 198 481 02MX</b> <b>98-1812-S</b> Main Brg. Set, 1.00mm/ Std./2.00mm, 1200-1600cc, Type 1 61-79, Ghia 61-74, Type 2 61-71, Type 3 thru 73</p>  	<p><b>111 198 485MX</b> <b>98-1485-S</b> Main Brg. Set, 1.00mm/.50mm, 1200-1600cc, Type 1 61-79, Ghia 61-74, Type 2 61-71, Type 3 thru 73</p>  	<p><b>111 198 491 80MX</b> <b>98-1480-S</b> Main Brg. Set, 2.00mm/ Std./2.00mm, 1200-1600cc, Type 1 61-79, Ghia 61-74, Type 2 61-71, Type 3 thru 73</p>  
<p><b>111 198 483</b> <b>98-1483-A</b> Main Brg. Set, 1.00mm/.25mm, 1200-1600cc, Type 1 61-79, Ghia 61-74, Type 2 61-71, Type 3 thru 73</p>  	<p><b>111 198 4850SMX</b> <b>98-1850-S</b> Main Brg. Set, 1.00mm/.50mm/1.00mm, 1200-1600cc</p>  	<p><b>111 198 493 60MX</b> <b>98-1493-S</b> Main Brg. Set, 1.5mm/.25mm/2.00mm, 1200-1600cc, Type 1 61-79, Ghia 61-74, Type 2 61-71, Type 3 thru 73</p>  



# REPLACEMENT PARTS

<p><b>111 198 493 80MX</b> <b>98-1498-S</b> Main Brg. Set, 2.00mm/.25mm/2.00mm, 1200-1600cc</p> 	<p><b>111 198 541MC</b> <b>98-1544-C</b> Cam Bearing Set, Std. 1300-1600cc Mahle / Clevite - Mexico</p>  <p><b>MAHLE</b></p>	<p><b>95-2005-B •</b> Gas Cap (Fits Replacement Tanks 95-2001-B &amp; 95-2004-B Only)</p> 
<p><b>111 198 495 60</b> <b>98-1495-A</b> Main Brg. Set, 1.50mm/.50mm/2.00mm, 1200-1600cc, Type 1 61-79, Ghia 61-74, Type 2 61-71, Type 3 thru 73</p>  <p><b>MAHLE</b></p>	<p><b>111 198 541HDMX</b> <b>98-1543-S</b> Cam Bearing Set, Std. 1300-1600cc, Double Thrust, Type 1 66-79, Ghia 66-74, Type 2 63-71, Vanagon 83-85, Type 3 64-73</p> 	<p><b>113 201 075AD</b> <b>95-2000-B</b> Fuel Tank, Type 1 68-77, Ghia 68-74 See page 134 for all tanks</p>  
<p><b>111 198 495 60MX</b> <b>98-1495-S</b> Main Brg. Set, 1.50mm/.50mm/2.00mm, 1200-1600cc, Type 1 61-79, Ghia 61-74, Type 2 61-71, Type 3 thru 73</p> 	<p><b>111 198 569C</b> <b>00-2355-0 •</b> Carburetor Tune-Up Kit, VW Type 1, 40HP</p> 	<p><b>133 201 075F</b> <b>95-2002-B</b> Fuel Tank, All Super Beetle (71-74) See page 134 for all tanks</p>  
<p><b>111 198 495 80MX</b> <b>98-1594-S</b> Main Brg. Set, 2.00mm/.50mm/2.00mm, 1200-1600cc</p> 	<p><b>113 198 575URK</b> <b>00-2500-0 •</b> Carburetor Rebuild Kit, 1200-1600cc, Type 1 61-74, Ghia 61-74, Type 2 61-71</p> 	<p><b>133 201 075G</b> <b>95-2003-B</b> Fuel Tank, Super Beetle, Type 1 75-79 See page 134 for all tanks</p>  
<p><b>111 198 497 60MX</b> <b>98-1596-S</b> Main Brg. Set, 1.50mm/.75mm/2.00mm, 1200-1600cc</p> 	<p><b>111 199 101</b> <b>98-1003-B •</b> Starter Bolt, Type 1 67-79, Ghia 67-74, Type 2 63-71, Type 3 64-73, Each</p> 	<p><b>311 201 219A</b> <b>98-2106-B</b> Hose, Fuel Filler Neck, 213mm Length, 48mm I.D. Type 1 68-79, Ghia 68-74, Type 3 68-73</p> 
<p><b>111 198 497 80MX</b> <b>98-1595-S</b> Main Brg. Set, 2.00mm/.75mm/2.00mm, 1200-1600cc</p> 	<p><b>211 201 055B</b> <b>95-2008-B</b> Gas Tank, Type 2, 55-67 See page 134 for all tanks</p>  	<p><b>803 201 511C</b> <b>00-9100-0</b> Fuel Filter, (Sold 10 to a box), Type 1 thru 74, Ghia thru 74, Type 2 thru 71, Type 3 64-67</p> 
<p><b>021 198 541</b> <b>98-1453-B</b> Cam Bearing Set, Type 2 72-79, Vanagon 80-83</p>  <p><b>MAHLE</b></p>	<p><b>113 201 075/16</b> <b>95-2004-B</b> Fuel Tank, Extra Capacity, 12 1/2 Gallon, Type 1 61-67 *Must use Gas Cap 95-2005-B</p>  	<p><b>113 201 551A</b> <b>98-2104-B •</b> Gas Cap, Type 1 68-71, Ghia 68-71, Type 3 67-8/72</p> 
<p><b>111 198 541MX</b> <b>98-1544-S</b> Cam Bearing Set, Std. 1300-1600cc</p> 	<p><b>113 201 075AB</b> <b>95-2001-B</b> Fuel Tank, Type 1 61-67 *Must use Gas Cap 95-2005-B</p>  	<p><b>113 201 551AL</b> <b>98-2114-B •</b> Gas Cap, Type 1 68-71, Ghia 68-71, Type 3 67-8/72</p>  

(•) Also available in skinpack **477**







# REPLACEMENT PARTS



<p><b>321 201 551H</b> <b>98-2105-B •</b> Locking Gas Cap, Type 1 72-79, Ghia 72-74, Type 3 72-73</p> 	<p><b>111 251 261B</b> <b>98-2516-B</b> Exhaust Flange Gasket Metal Clad, Type 1 50-79, Ghia 56-74, Type 2 50-71, Type 3 64-73, Each</p> 	<p><b>111 255 355B</b> <b>98-2524-B</b> Warm Air Hose, 65 &amp; Prior, 14" Long, 50/50mm, Each</p> 
<p><b>111 209 147A</b> <b>98-2109-B •</b> Fuel Tank Screen, All 50-74, Each</p> 	<p><b>043 255 107HD</b> <b>95-3012-B</b> Left Heater Box, Type 1 63-74, Ghia 63-74, Type 2 63-71</p> 	<p><b>113 255 355C</b> <b>98-2518-B</b> Air Hose, Heater Box/ Body, Pass. Side, 60/50mm, 14 1/2" long, 1600 in 64 &amp; Earlier, Each</p> 
<p><b>616 211 295 01</b> <b>00-3379-0</b> Fresh Air Hose, <b>Aluminum</b>, 63 x 1000mm, Type 3 64-73, Each</p> 	<p><b>043 255 108HD</b> <b>95-3013-B</b> Right Heater Box, Type 1 63-74, Ghia 63-74, Type 2 63-71</p> 	<p><b>113 255 355D</b> <b>98-2519-B</b> Air Hose, Heater Box to Body, Driver Side, 60/64mm, 15" long, Type 1 65-67, Each</p> 
<p><b>211 251 051E</b> <b>95-3004-B</b> Euro-Made Stock Replacement Muffler Type 2, 1500-1600cc</p> 	<p><b>113 255 107X</b> <b>00-9914-B •</b> Heater Box Repair Pipe, Type 1 63-74, Ghia 63-74, Type 2 63-71, Each</p> 	<p><b>113 255 355M</b> <b>98-2520-B</b> Air Hose, Heater Box to Body, Pass. Side, 60/60mm, 14" long, Type 1 68-72, Each</p> 
<p><b>111 251 051H</b> <b>95-3002-B</b> Euro-Made Stock Replacement Muffler Type 1, 40HP/1200cc</p> 	<p><b>113 255 165</b> <b>98-1004-B •</b> Fresh Air Hose Connector, Type 1 63-74, Ghia 63-74, Type 2 63-71, Each</p> 	<p><b>111 298 009F</b> <b>98-2989-B •</b> Muffler Installation Kit, Type 1 63-74, Ghia 63-74</p> 
<p><b>113 251 053AKEU</b> <b>95-3003-B</b> Muffler, 1300-1600cc, Type 1 66-71, Ghia 66-71 Euro-Made</p> 	<p><b>113 255 292P</b> <b>98-2088-B •</b> Fresh Air Hose, Plastic, 10 1/4" long, Type 1 63-74, Ghia 63-74, Type 2 63-71, Each</p> 	<p><b>111 298 051</b> <b>00-3394-B •</b> Tail Pipe Clamp, Type 1 56-74, Ghia 56-74, Each</p> 
<p><b>113 251 163C</b> <b>00-9915-B •</b> Tail Pipe Tip, (250mm) Type 1 61-74, Ghia 61-74, Each</p> 	<p><b>113 255 341A</b> <b>98-2517-B</b> Clamp, Heat Exchanger (25mm Wide), Type 1 63-74, Each</p> 	<p><b>043 298 147A</b> <b>95-3014-B •</b> Left Heater Box Lever Kit, Type 1 63-74, Ghia 63-74, Type 2 63-71</p> 
<p><b>113 251 163TT</b> <b>00-3693-B •</b> Tapered Baffled Tail Pipe Tip, Type 1 61-74, Ghia 61-74, Each</p> 	<p><b>043 255 355A</b> <b>98-2521-B</b> Air Hose, Heater Box to Body, Driver Side, 60/60mm, 17" long, Type 1 73-79, Each</p> 	<p><b>043 298 148A</b> <b>95-3015-B •</b> Right Heater Box Lever Kit, Type 1 63-74, Ghia 63-74, Type 2 63-71</p> 



# REPLACEMENT PARTS

<p><b>113 298 221</b> <b>95-2006-B •</b> Fuel Tank Outlet Pipe Kit, Type 1 thru 74, Ghia thru 74</p> 	<p><b>311 301 265A</b> <b>98-2075-B •</b> Transmission Mount, Front, Type 1 62-65, Ghia 62-65, Type 3 64-65, Each</p> 	<p><b>111 405 129</b> <b>98-4042-B</b> Seal, Torsion Arm, Upper/ Lower, Type 1 50-65, Ghia 56-65, Each</p> 
<p><b>113 301 205G</b> <b>98-3006-B</b> Gearshift Housing w/ Gasket, Type 1 62-72 (Mexico)</p> 	<p><b>311 301 265B</b> <b>98-2076-B •</b> Transmission Mount, Front, Type 1 66-72, Ghia 66-72, Type 3 66-67, Each</p> 	<p><b>131 405 129</b> <b>98-4043-B</b> Seal, Trailing Arm, Lower, Type 1 66-77, Ghia 66-74, Each</p> 
<p><b>211 301 215</b> <b>98-3008-B</b> Replacement Gasket Only, Shift Housing, Type 1 62-72, Ghia 62-72, Type 3 64-73, Each</p> 	<p><b>113 301 265E</b> <b>98-9972-B •</b> Transmission Mount, Front, Type 1 73 &amp; Later, Each</p> 	<p><b>131 405 131</b> <b>98-4045-B</b> Seal, Trailing Arm, Upper, Type 1 66-77, Ghia 66-74, Each</p> 
<p><b>001 301 227</b> <b>98-3009-B</b> Oil Seal, Transmission, Type 1 69-79, Each</p> 	<p><b>111 301 289B</b> <b>98-2072-B</b> Boot, Nosecone to Chassis, Type 1 61-79, Ghia 61-74, Type 3 64-73, Each</p> 	<p><b>113 405 311D/2D</b> <b>22-2952-0</b> New Spindles, Stock Ball Joint, Pair</p>  <p><b>NEW! NOT REBUILT</b></p>
<p><b>113 301 263</b> <b>98-2074-B •</b> Transmission Mount, Cradle, Type 1 52-72, Ghia 56-72, Type 2 52-67, Type 3 64-73, Each</p> 	<p><b>113 311 113A</b> <b>98-3014-B</b> Seal, Transmission Main Shaft (22 x 40 x 13/16), Type 1 50-79, Ghia 56-74, Type 2 50-71, Type 3 64-73, Each</p> 	<p><b>131 405 361F</b> <b>98-4522-B</b> Upper Ball Joint, Type 1 66-77, Ghia 66-74, Each</p> 
<p><b>113 301 263C</b> <b>98-2070-B</b> Transmission Mount Left Rear Type 1, 73-79, Each</p> 	<p><b>113 311 541C</b> <b>98-3015-B</b> Shift Lever, Transmission, Type 1 61-79, Ghia 61-74, Each</p> 	<p><b>211 405 371A</b> <b>98-4524-B</b> Ball Joint, Type 2 68-79 Each</p>  <p><b>NEW!</b></p>
<p><b>113 301 264</b> <b>98-2071-B</b> Transmission Mount, Right Rear, Type 1 73-79, Each</p> 	<p><b>111 398 005A</b> <b>98-2077-B •</b> Transmission Rebuilding Gasket Kit, Type 1 61-76, Ghia 61-74, Type 2 61-67, Type 3 64-73</p> 	<p><b>131 405 371G</b> <b>98-4523-B</b> Lower Ball Joint, Type 1 66-77, Ghia 66-74, Each</p> 
<p><b>211 301 265A</b> <b>98-2073-B</b> Transmission Mount, Front, Type 2 63-67, Each</p> 	<p><b>111 401 273</b> <b>98-4041-B</b> Rubber Stop, Suspension Travel, Type 1 50-65, Ghia 56-65, Each</p> 	<p><b>211 405 579</b> <b>18-1019-0</b> Front Hub Assembly, Type 2, 71-79, Each</p>  <p><b>NEW!</b></p>

(•) Also available in skinpack **479**

# REPLACEMENT PARTS











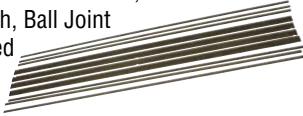



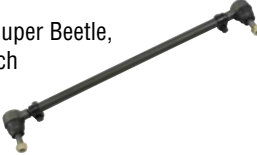









<p><b>102 405 593</b> <b>22-2849-B</b> Front Disc Brake Backing Plate, Each</p> 	<p><b>311 405 625B</b> <b>98-1154-B</b> Inner Front Wheel Roller Bearing, Type 1 69-79, Ghia 69-74, Type 3 69-73, Each</p> 	<p><b>211 405 641D</b> <b>18-1035-0</b> <span style="color:red">NEW!</span> Front Grease Seal, Front, Type 2, 68-79, Each</p> 
<p><b>113 405 615A</b> <b>98-4002-B</b> Front Brake Drum, Type 1 58-65, Ghia 58-65, Each</p> 	<p><b>111 405 627</b> <b>98-4626-B</b> Inner Front Wheel Roller Bearing, Type 1 50-65, Ghia 56-65, Each</p> 	<p><b>311 405 645</b> <b>98-1155-B</b> Outer Front Wheel Roller Bearing, Type 1 66-79, Ghia 66-74, Type 3 66-73, Each</p> 
<p><b>131 405 615A</b> <b>98-4600-B</b> Front Brake Drum, Type 1 66-67, Each</p> 	<p><b>111 405 631B</b> <b>98-4046-B</b> Spacer, Front Wheel Bearing, Type 1 50-65, Ghia 56-65, Each</p> 	<p><b>211 405 645D</b> <b>98-4623-B</b> Outer Front Wheel Roller Bearing, Type 2 64-79, Vanagon 80-83, Each</p> 
<p><b>111 405 615B</b> <b>98-4001-B</b> Front Brake Drum (Exc. Super Beetle), Type 1 68-77, Each</p> 	<p><b>111 405 641A</b> <b>98-4618-B</b> Front Wheel Seal, Type 1 50-65, Ghia 56-65, Each</p> 	<p><b>111 405 647</b> <b>98-4625-B</b> Outer Front Wheel Roller Bearing, Type 1 50-65, Ghia 56-65, Each</p> 
<p><b>211 405 615C</b> <span style="color:red">NEW!</span> <b>98-4602-B</b> Front Brake Drum, Type 2 64-70 For 64-67 Type 2 Applications, use Seal P/N: 211 405 641B</p> 	<p><b>131 405 641A</b> <b>98-4627-B</b> Front Wheel Seal, Type 1 66-6/68, Ghia 66-6/68, Each</p> 	<p><b>111 405 661</b> <b>98-4047-B</b> Thrust Washer, Wheel Bearing, Type 1 50-65, Type 1 56-65, Each</p> 
<p><b>113 405 615H</b> <b>98-4601-B</b> Front Brake Drum, Super Beetle, Type 1 71-79, Each</p> 	<p><b>211 405 641A</b> <b>98-4617-B</b> Front Wheel Seal, Type 2 55-63, Each</p> 	<p><b>311 405 661</b> <b>98-4048-B</b> Thrust Washer, Wheel Bearing, Type 1 66-79, Ghia 66-74, Type 3 64-73, Each</p> 
<p><b>211 405 625</b> <b>98-4620-B</b> Inner Front Wheel Roller Bearing, Type 2 64-79, Each</p> 	<p><b>111 405 641B</b> <b>98-4621-B</b> Front Wheel Seal, Type 1 7/68-79, Ghia 7/68-74, Each</p> 	<p><b>131 405 669</b> <b>98-4049-B</b> Spindle Clamp Nut w/ screw, 16mmx1.5 Left, Type 1 66 &amp; Later, Type 3 64 &amp; Later, Each</p> 
<p><b>311 405 625</b> <b>98-4622-B</b> Inner Front Wheel Roller Bearing, Type 1 66-68, Ghia 66-68, Type 3 66-68, Each</p> 	<p><b>211 405 641B</b> <b>98-4624-B</b> Front Wheel Seal, Type 2 64-67, Each</p> 	<p><b>131 405 670</b> <b>98-4050-B</b> Spindle Clamp Nut w/ screw, 16mmx1.5 Right, Type 1 66 &amp; Later, Type 3 64 &amp; Later, Each</p> 



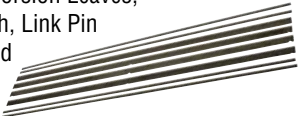

# REPLACEMENT PARTS

<p><b>111 405 671</b> <b>98-4051-B</b> Hex Nut, Spindle, Left, Type 1 50-65, Ghia 56-65, Each</p> 	<p><b>131 411 107A</b> <b>98-4541-B</b> Replacement Torsion Leaves, Standard Width, Ball Joint 2 Sets Required Per Beam</p> 	<p><b>113 415 801</b> <b>98-4591-B</b> Tie Rod, Left, Type 1 thru 65, Ghia 56-65, Each</p> 
<p><b>111 405 672</b> <b>98-4052-B</b> Hex Nut, Spindle, Right, Type 1 50-65, Ghia 56-65, Each</p> 	<p><b>111 411 151</b> <b>98-4166-B</b> Grub Screw for Torsion Bar, Type 1 50-77, Ghia 56-74, Type 2 50-79, Type 3 64-73, Each</p> 	<p><b>133 415 801</b> <b>98-4584-B</b> Tie Rod, L &amp; R, Super Beetle, Type 1 71-74, Each</p> 
<p><b>111 405 681</b> <b>98-4057-B</b> Lock Plate, Spindle Nut, Type 1 50-65, Ghia 56-65, Each</p> 	<p><b>111 411 155</b> <b>98-4165-B</b> Nut for Grub Screw, Type 1 50-77, Ghia 56-74, Type 2 50-79, Type 3 64-73, Each</p> 	<p><b>131 415 801F</b> <b>98-4587-B</b> Tie Rod, Left, Type 1 5/68-77, Ghia 5/68-74, Each</p> 
<p><b>211 405 681</b> <b>98-4058-B</b> Lock Plate, Spindle Nut, Type 2 50-63, Each</p> 	<p><b>113 413 031E</b> <b>00-9651-0</b> EMPI Shock, Front, Ball Joint, Stock Height, 16", Type 1, Ghia 66 on, Each</p> 	<p><b>211 415 801F</b> <b>98-4583-B</b> Tie Rod, Left, Type 2 68-79, Each</p> 
<p><b>113 407 075</b> <b>98-1153-B</b> Front Brake Disc, Type 1 66-79, Ghia 66-74, Type 3 66-71, Each</p> 	<p><b>113 415 061C</b> <b>98-4155-B</b> <b>TRW / Varga</b> Steering Box, All Type 1 &amp; 3 (Exc. Super Beetle), New outright, (No Core)</p>  <p><b>NEW! NOT REBUILT</b></p>	<p><b>113 415 802B</b> <b>98-4590-B</b> Tie Rod, Right, Type 1 thru 65, Ghia 56-65, Each</p> 
<p><b>113 407 361E</b> <b>98-4525-B</b> Ball Joint, Super Beetle. Type 1 71-5/73, Each</p> 	<p><b>113 415 061CBR</b> <b>98-4156-B</b> Steering Box, All Type 1 &amp; 3 (Exc. Super Beetle), New outright, (No Core)</p>  <p><b>NEW! NOT REBUILT</b></p>	<p><b>131 415 802E</b> <b>98-4586-B</b> Tie Rod, Right, Type 1 5/68-77, Ghia 5/68-74, Each</p> 
<p><b>014 409 135A</b> <b>98-5144-B</b> Special Bolt for Ring Gear (9mm), Each</p> 	<p><b>111 415 417</b> <b>98-4168-B</b> Coupling Disc, Steering Shaft, Type 1 50-78, Ghia 56-74, Type 3 64-73, Each</p> 	<p><b>131 415 811</b> <b>98-4511-B</b> Tie Rod End, Left Outer, Type 1 thru 5/68, Ghia 56-5/68, Type 2 55-67, Each</p> 
<p><b>111 411 027</b> <b>98-4540-B</b> Replacement Torsion Leaves, Standard Width, Link Pin 2 Sets Required Per Beam</p> 	<p><b>211 415 417</b> <b>98-4169-B</b> Coupling Disc, Steering Shaft, Type 2 68-79</p>  <p><b>NEW!</b></p>	<p><b>311 415 811C</b> <b>98-4513-B</b> Tie Rod End, Left Outer, Type 1 5/68-79, Ghia 5/68-74, Type 2 68-73, Each</p> 

(•) Also available in skinpack **481**

# REPLACEMENT PARTS



<p><b>131 415 812</b> <b>98-4512-B</b> Tie Rod End, Right Outer, Type 1 thru 5/68, Ghia 56-5/68, Type 2 55-67, Each</p> 	<p><b>113 425 021</b> <b>98-4251-B</b> Steering Damper, Exc. Super Beetle, Type 1 61-79, Ghia 61-74, Each</p> 	<p><b>113 501 149</b> <b>86-1084-V •</b> C.V. Joint Boot w/Flange, Type 1 68-79, Ghia 68-74, Type 3 68-73, Each</p> 
<p><b>311 415 812C</b> <b>98-4514-B</b> Tie Rod End, Right Outer, Type 1 5/68-79, Ghia 5/68-74, Type 2 68-73, Each</p> 	<p><b>211 425 021A</b> <b>98-4253-B</b> Steering Damper, Type 2 55-79, Each</p> 	<p><b>211 501 149</b> <b>86-1086-V •</b> C.V. Joint Boot w/Flange, Type 2 68-79, Vanagon 80-92, Each</p> 
<p><b>113 415 813</b> <b>98-4515-B</b> Tie Rod End, Right Inner, Type 1 thru 65, Ghia 56-65, Each</p> 	<p><b>111 498 021</b> <b>98-2065-B •</b> King Pin Rebuilding Kit, Type 1 thru 65, Ghia 56-65</p> 	<p><b>211 501 191</b> <b>98-5011-B •</b> Rubber Stop, Rear Axle, Type 2 65-79, Each</p> 
<p><b>113 415 813D</b> <b>98-4516-B</b> Tie Rod End, Right Inner, Type 1 66-5/68, Ghia 66-5/68, Each</p> 	<p><b>111 498 051A</b> <b>98-2066-B •</b> Link Pin Rebuilding Kit, Type 1 thru 65, Ghia 56-65</p> 	<p><b>311 501 191</b> <b>98-5012-B</b> Rubber Stop, Rear Axle, Type 1 60-79, Ghia 60-74, Type 3 64-73, Each</p> 
<p><b>131 415 813E</b> <b>98-4517-B</b> Tie Rod End, Right Inner, Type 1 5/68-77, Ghia 5/68-74, Each</p> 	<p><b>111 498 101A</b> <b>98-4172-B</b> Mounting Kit, Stabilizer Bar (Both Sides), Type 1 66-77, Ghia 66-74</p> 	<p><b>113 501 201D</b> <b>90-6900-C</b> New Drive Axle Assembly, Type 1 &amp; Ghia 68-79, w/ I.R.S., Each</p> 
<p><b>113 415 821</b> <b>98-4518-B</b> Tie Rod End, Left Inner, Type 1 thru 5/68, Ghia 56-5/68, Each</p> 	<p><b>211 498 171A</b> <b>98-4174-B</b> Swing Lever Rebuild Kit, Type 2 68-79</p> 	<p><b>211 501 203</b> <b>90-6903-C</b> New Drive Axle Assembly, Type 2 68-79, M/T w/ I.R.S., Each</p> 
<p><b>131 415 821A</b> <b>98-4519-B</b> Tie Rod End, Left Inner, Type 1 5/68-77, Ghia 5/68-74, Each</p> 	<p><b>131 498 441</b> <b>98-4175-B</b> Mount Kit, Front Shock Absorber, Type 1 66-77, Ghia 66-74</p> 	<p><b>251 501 203</b> <b>90-6802-0</b> New Drive Axle Assembly, Vanagon 80-82, M/T, Each</p> 
<p><b>113 415 951B</b> <b>98-4151-B</b> Steering Shaft w/Joints, Super Beetle, Type 1 71-74, Each</p> 	<p><b>447 501 113</b> <b>90-6905-0</b> New Drive Axle Assembly, Thing 73-75, w/ I.R.S., Each</p> 	<p><b>251 501 203A</b> <b>90-6800-0</b> New Drive Axle Assembly, Vanagon 80-82, A/T, Left, Each</p> 



# REPLACEMENT PARTS

<p><b>251 501 203E</b> <b>90-6804-C</b> New Drive Axle Assembly, Vanagon 83-92, A/T, Left, Each</p> 	<p><b>311 501 283</b> <b>98-5016-B</b> Ball Bearing, Rear Axle &amp; Reduction Box, Swing Axle, Type 1 50-68, Ghia 56-68, Type 2 50-67, Type 3 64-67, Each</p> 	<p><b>930 332 034 00E</b> <b>87-9469-B</b> C.V. Joint, 930, <b>EMPI</b> Brand, Each</p> 
<p><b>251 501 203G</b> <b>90-6805-0</b> New Drive Axle Assembly, Vanagon Syncro 86-92, Rear Both Sides, Each</p> 	<p><b>111 501 303B</b> <b>22-5281-7</b> Replacement Spacer for I.R.S. Rotor, Each</p> 	<p><b>181 501 615A</b> <b>98-5019-B</b> <b>NEW!</b> Rear Brake Drum, Thing, All Years, Each</p> 
<p><b>251 501 204B</b> <b>90-6803-C</b> New Drive Axle Assembly, Vanagon 83-92, A/T, Right, Each</p> 	<p><b>113 501 315H</b> <b>98-5021-B</b> Oil Seal, Rear Axle, Type 1 50-68, Ghia 56-68, Type 2 50-67, Type 3 64-67, Each</p> 	<p><b>113 501 615D</b> <b>98-5001-B</b> Rear Brake Drum, Type 1 58-67, Ghia 58-65, Each</p> 
<p><b>311 501 221</b> <b>16-2421-7 •</b> Axle Spindle Nut, 36mm, Type 1 67-79, Ghia 67-74, Type 3 64-73, Each</p> 	<p><b>113 501 329</b> <b>87-5080-0</b> Torque Distribution T-1 Washer for 90mm Joint, Each</p> 	<p><b>311 501 615E</b> <b>98-5007-B</b> Rear Brake Drum, Type 3 63-65, Each</p> 
<p><b>113 501 229D</b> <b>87-7701-0 •</b> Bolt for Type 1 C.V., M8 x 1 15/16", 12 Pt. Internal, Each (Bulk)</p> 	<p><b>113 501 331</b> <b>87-9916-0</b> C.V. Joint, Type 1 68-79, Ghia 68-74, Type 3 68-73, Each</p> 	<p><b>211 501 615E</b> <b>98-5003-B</b> Rear Brake Drum, Type 2 64-67</p> 
<p><b>113 501 231</b> <b>16-2308-0</b> Standard Size Stub Axle for Type 1, 8mm Threads, Each</p> 	<p><b>211 501 331B</b> <b>87-9917-0</b> C.V. Joint, Type 2 68-79, Vanagon 80-92, Each</p> 	<p><b>311 501 615F</b> <b>98-5008-B</b> Rear Brake Drum, Type 3 66-73, Each</p> 
<p><b>113 501 277A</b> <b>98-5014-B</b> Roller Bearing, Rear Axle, I.R.S., Outer, Type 1 68-79, Ghia 68-74, Type 3 68-73, Each</p> 	<p><b>211 501 357</b> <b>87-5081-0</b> Torque Distribution T-2 Washer for 100mm Joint, Each</p> 	<p><b>211 501 615G</b> <b>98-5005-B</b> Rear Brake Drum, Type 2 68-70</p> 
<p><b>113 501 283</b> <b>98-5015-B</b> Ball Bearing, Rear Axle, I.R.S., Inner, Type 1 68-79, Ghia 68-74, Type 3 68-73, Each</p> 	<p><b>930 332 034 00</b> <b>98-5093-B</b> C.V. Joint, 930, <b>Lobro</b> (EMPI Version Use P/N: 87-9469-B), Each</p> 	<p><b>113 501 615J</b> <b>98-5002-B</b> Rear Brake Drum, Type 1 68-79, Ghia 68-74, Each</p> 

# REPLACEMENT PARTS



<p><b>321 501 641</b> <b>98-1156-B</b> Front Wheel Seal w/Disc Brakes, Type 1 66-79, Ghia 66-74, Type 3 66-73, Each</p> 	<p><b>311 598 051B</b> <b>00-9910-B •</b> Rear Axle Seal Kit, Type 1 thru 79, Ghia 56-74, Type 2 thru 67, Type 3 64-73</p> 	<p><b>113 609 205A</b> <b>98-6115-B</b> Adjusting Star, Brake Shoe, Type 1 50-79, Ghia 56-74, Type 2 55-79, Type 3 64-73, Each</p> 
<p><b>311 511 245</b> <b>98-5102-B</b> Bushing, Spring Plate, Left/Outer, Right/Inner, Type 1 60-68, Ghia 60-68, Type 3 64-67, Each</p> 	<p><b>111 598 151</b> <b>00-9917-B •</b> Solid Axle Boot Kit, Each, Type 1 50-68, Ghia 56-68, Type 2 50-67, Type 3 64-68</p> 	<p><b>131 609 209</b> <b>98-6116-B</b> Adjusting Screw, Brake Shoe, Type 1 65-79, Ghia 65-74, Type 3 64-73, Each</p> 
<p><b>111 511 245E</b> <b>98-5101-B</b> Bushing, Spring Plate, Outer, Type 1 69-79, Ghia 69-74, Type 3 68-73, Each</p> 	<p><b>113 598 201</b> <b>86-1084-1</b> Deluxe CV Joint Boot Kit, Type 1</p> 	<p><b>211 609 209</b> <b>98-6117-B</b> Adjusting Screw, Brake Shoe, Type 1 58-64, Ghia 58-64, Type 2 50-55, Each</p> 
<p><b>311 511 246</b> <b>98-5103-B</b> Bushing, Spring Plate, Left/Inner, Right/Outer, Type 1 60-68, Ghia 60-68, Type 3 64-67, Each</p> 	<p><b>251 598 201</b> <b>86-1086-1</b> Deluxe CV Joint Boot Kit, Type 2</p> 	<p><b>113 609 237A</b> <b>98-6090-B</b> Brake Shoe Set, Front or Rear, Type 1 49-57 (162)</p> 
<p><b>113 513 031G</b> <b>00-9652-0</b> EMPI Shock, Front, Link Pin, Type 1, Ghia thru 65, Type 2 thru 67, Each</p> 	<p><b>111 601 139</b> <b>98-6111-B</b> Bolt, Road Wheel (12 x 1.5mm), Type 1 50-67, Ghia 56-67, Type 3 64-65, Each</p> 	<p><b>131 609 237C</b> <b>98-6093-B</b> Brake Shoe Set, Front, Type 1 65-77 Ghia 1965, Except Super Beetle, (269)</p> 
<p><b>113 513 031N</b> <b>00-9652-0</b> EMPI Shock, Rear, 11 3/4", All I.R.S. / Swing Axle, Type 1, Ghia, Type 2, Type 3, Each</p> 	<p><b>251 601 139</b> <b>98-6112-B</b> Bolt, Road Wheel (14 x 1.5mm), Type 1 68-79, Ghia 68-74, Type 2 thru-70, Type 3 66-73, Each</p> 	<p><b>113 609 237D</b> <b>98-6091-B</b> Brake Shoe Set, Front, Type 1 58-64, Ghia 58-64, (167)</p> 
<p><b>002 517 289A</b> <b>98-5140-B</b> Plug, Final Drive, Type 2 69-79, Each (New Tooling)</p> 	<p><b>111 601 173</b> <b>98-6113-B</b> Cap, (Black) Wheel Bolt, Type 1 73-79, Each</p> 	<p><b>211 609 237D</b> <b>98-6094-B</b> Brake Shoe Set, Front, Type 2 64-70, (297)</p> 
<p><b>111 598 021A</b> <b>00-9916-B •</b> Axle Boot Kit, Swing Axle, Type 1 thru 68, Ghia 56-68, Type 2 thru 67, Type 3 64-67</p> 	<p><b>113 609 163</b> <b>98-6114-B</b> Plug, Brake Adjuster Hole, Type 1 68-79, Each</p> 	<p><b>113 609 237H</b> <b>98-6092-B</b> Brake Shoe Set, Front, Super Beetle, Type 1 71-79, (392)</p> 



# REPLACEMENT PARTS

<p><b>113 609 537B</b> <b>98-6095-B</b> Brake Shoe Set, Rear, Type 1 58-64, Ghia 58-64, <b>(168)</b></p> 	<p><b>133 609 721</b> <b>98-6903-B</b> Emergency Brake Cable, Type 1 73-79, Ghia 73-74, Each</p> 	<p><b>113 611 015BDD</b> <b>16-9554-0</b> 20.6mm Dual Circuit Master Cylinder (All Beetles), Each</p> 
<p><b>113 609 537C</b> <b>98-6096-B</b> Brake Shoe Set, Rear, Type 1 68-79, Ghia 68-74, <b>(315)</b></p> 	<p><b>113 609 721F</b> <b>98-6900-B</b> Emergency Brake Cable, Type 1 58-64, Ghia 58-64, Each</p> 	<p><b>113 611 015BH</b> <b>98-6003-B</b> Master Cylinder, Super Beetle, Type 1 71-79</p> 
<p><b>131 609 537C</b> <b>98-6097-B</b> Brake Shoe Set, Rear, Type 1 65-67, Ghia 65-67, <b>(270)</b></p> 	<p><b>113 609 721J</b> <b>98-6902-B</b> Emergency Brake Cable, Type 1 68-72, Ghia 68-72, Each</p> 	<p><b>113 611 015BHCH</b> <b>98-6203-B</b> Master Cylinder, Super Beetle, 71-79</p> 
<p><b>211 609 537E</b> <b>98-6098-B</b> Brake Shoe Set, Rear, Type 2 64-70, <b>(298)</b></p> 	<p><b>113 609 721L</b> <b>98-6901-B</b> Emergency Brake Cable, Type 1 65-67, Ghia 65-67, Each</p> 	<p><b>133 611 015HDD</b> <b>17-2808-0</b> 20.6mm Dual Circuit Master Cylinder <b>(Super Beetle Only)</b>, Ea</p> 
<p><b>211 609 601B</b> <b>98-6118-B</b> Anchor Pin, Parking Brake Lever (use w/211 609 619), Type 1 50-79, Ghia 56-74, Type 2 55-79, Type 3 64-73, Each</p> 	<p><b>211 611 011J</b> <b>98-6001-B</b> Master Cylinder, Type 2 55-66</p> 	<p><b>211 611 021AA</b> <b>98-6005-B</b> Master Cylinder, Type 2 68-79</p> 
<p><b>113 609 614A</b> <b>98-6120-B</b> Lever, Parking Brake, Right, Type 1 58-79, Ghia 58-74, Each</p> 	<p><b>211 611 011JCH</b> <b>98-6021-B</b> Master Cylinder, Type 2, 55-66</p> 	<p><b>211 611 021AACH</b> <b>98-6205-B</b> Master Cylinder, Type 2, 68-79</p> 
<p><b>211 609 619</b> <b>98-6121-B</b> C Clip, Parking Brake Lever Pin, Type 1 50-79, Ghia 56-74, Type 2 55-79, Type 3 64-73, Each</p> 	<p><b>113 611 015BD</b> <b>98-6002-B</b> Master Cylinder, Type 1 67 on (Exc. SB)</p> 	<p><b>113 611 021C</b> <b>98-6004-B</b> Master Cylinder, 19mm, Type 1 50-64, Ghia 56-64</p> 
<p><b>311 609 631</b> <b>98-6122-B</b> Push Bar, Parking Brake, Type 1 58-79, Ghia 58-74, Each</p> 	<p><b>113 611 015BDCH</b> <b>98-6019-B</b> Master Cylinder, Type 1 67 on (Exc. SB)</p> 	<p><b>113 611 021CCH</b> <b>98-6204-B</b> Master Cylinder, 19mm, Type 1 50-64, Ghia 56-64</p> 

(•) Also available in skinpack **485**









# REPLACEMENT PARTS



<p><b>113 611 023B</b> <b>98-6006-B</b> Master Cylinder, 17mm, Type 1 65-66, Ghia 65-66</p>  	<p><b>131 611 055</b> <b>98-6013-B</b> Wheel Cylinder, Rear, Type 1 65-67, Ghia 65-67, Each</p>  	<p><b>311 611 067C</b> <b>98-6015-B</b> Wheel Cylinder, Rear, Type 3 65-73, Each</p>  
<p><b>113 611 023BCH</b> <b>98-6206-B</b> Master Cylinder, 17mm, Type 1 65-66, Ghia 65-66</p> 	<p><b>113 611 055C</b> <b>98-6010-B</b> Wheel Cylinder, Rear, Type 1 58-64, Ghia 58-64, Each</p>  	<p><b>311 611 067CCH</b> <b>98-6215-B</b> Wheel Cylinder, Rear, Type 3 65-73, Each</p> 
<p><b>211 611 047C</b> <b>98-6007-B</b> Wheel Cylinder, Rear, Type 2 55-71, Each</p>  	<p><b>113 611 055CCH</b> <b>98-6210-B</b> Wheel Cylinder, Rear, Type 1 58-64, Ghia 58-64, Each</p> 	<p><b>211 611 069C</b> <b>98-6017-B</b> Wheel Cylinder, Left Front, Type 2 64-70, Each</p>  
<p><b>211 611 047CCH</b> <b>98-6207-B</b> Wheel Cylinder, Rear, Type 2 55-71, Each</p> 	<p><b>131 611 055CH</b> <b>98-6213-B</b> Wheel Cylinder, Rear, Type 1 65-67, Ghia 65-67, Each</p> 	<p><b>211 611 069CCH</b> <b>98-6217-B</b> Wheel Cylinder, Left Front, Type 2 64-70, Each</p> 
<p><b>211 611 047F</b> <b>98-6008-B</b> Wheel Cylinder, Rear, Type 2 72-79, Vanagon 80-92, Each</p>  	<p><b>113 611 057B</b> <b>98-6014-B</b> Wheel Cylinder, Front, Type 1 58-77, Ghia 58-65, Each</p>  	<p><b>211 611 070C</b> <b>98-6018-B</b> Wheel Cylinder, Right Front, Type 2 64-70, Each</p>  
<p><b>211 611 047FCH</b> <b>211 611 047DCH</b> <b>98-6208-B</b> Wheel Cylinder, Rear, Type 2 72-79, Vanagon 80-92, Each</p> 	<p><b>113 611 057BCH</b> <b>98-6214-B</b> Wheel Cylinder, Front, Type 1 58-77, Ghia 58-65, Each</p> 	<p><b>211 611 070CCH</b> <b>98-6218-B</b> Wheel Cylinder, Right Front, Type 2 64-70, Each</p> 
<p><b>113 611 053B</b> <b>98-6009-B</b> Wheel Cylinder, Rear, Type 1 68-79, Ghia 68-74, Each</p>  	<p><b>361 611 067A</b> <b>98-6016-B</b> Wheel Cylinder, Front, Super Beetle, Type 1 71-79, Each</p>  	<p><b>211 611 301C</b> <b>98-6020-B</b> Brake Fluid Reservoir, Type 2 55-66</p> 
<p><b>113 611 053BCH</b> <b>98-6209-B</b> Wheel Cylinder, Rear, Type 1 68-79, Ghia 68-74, Each</p> 	<p><b>361 611 067ACH</b> <b>98-6216-B</b> Wheel Cylinder, Front, Super Beetle, Type 1 71-79, Each</p> 	<p><b>113 611 301G</b> <b>98-6671-B •</b> Reservoir, Brake Fluid, Incl. Cap, Type 1 61-66, Ghia 61-66</p> 



# REPLACEMENT PARTS

<p><b>113 611 301L</b> <b>98-6672-B •</b> Reservoir, Brake Fluid, w/Cap, Type 1 68-79, Type 3 66-73</p> 	<p><b>113 611 715A</b> <b>98-6680-B</b> Bracket, Brake Line, Type 1 50-79, Ghia 56-74, Type 2 50-79, Type 3 64-73, Each</p> 	<p><b>113 611 764C</b> <b>98-9617-B</b> Steel Brake Line, 22" Length, Type 1 All, Each</p> 
<p><b>211 611 477A</b> <b>98-6023-B</b> Brake Bleeder Valve, Type 1 58-79, Ghia 58-74, Type 3 66-73, Each</p> 	<p><b>113 611 723A</b> <b>98-9601-B</b> Metal Brake Line 7.50", Each</p> 	<p><b>803 611 755</b> <b>98-6682-B</b> T-Piece, Rear Brake Fluid Distributor, Thread Size 10mm x 1.00 Each End, Type 1 50-79, Ghia 56-74, Type 3 64-73, Each</p> 
<p><b>211 611 483</b> <b>98-6024-B</b> Brake Bleeder Valve Cap, Type 1 58-79, Ghia 58-74, Type 2 50-79, Vanagon 80-92, Type 3 66-73, Each</p> 	<p><b>211 611 723A</b> <b>98-9619-B</b> Steel Brake Line, 28" Length, Type 1 All, Each</p> 	<p><b>211 611 775B</b> <b>98-6706-B</b> Brake Hose, Rear, F/F 270mm, Type 1/2/3 w/ Swing Axle, S/B 71-73 Front Type 2 Right Rear 68-79, Each</p> 
<p><b>113 611 701</b> <b>98-6700-B</b> Brake Hose, Front, Type 1 thru 64, Ghia 56-64, Type 2 thru 54, Each</p> 	<p><b>113 611 723JA</b> <b>98-9613-B</b> Steel Brake Line, 12" Length, Type 1 All, Each</p> 	<p><b>211 611 775C</b> <b>98-6709-B</b> Brake Hose, Universal Applications, 292mm Long, Each Type 2 68-79 Left Rear</p> 
<p><b>113 611 701D</b> <b>98-6701-B</b> Brake Hose, Front, w/Drum Brakes, Type 1 67-77, Each</p> 	<p><b>113 611 724J</b> <b>98-9620-B</b> Steel Brake Line, 31" Length, Type 1 All, Each</p> 	<p><b>113 611 775E</b> <b>98-6705-B</b> Brake Hose, Rear, Type 1 68-79, I.R.S Ghia 68-74, Each</p> 
<p><b>113 611 701E</b> <b>98-6702-B</b> Brake Hose, Front, Super Beetle, Type 1 74-79, Type 2 71-79, Each</p> 	<p><b>113 611 735D</b> <b>98-9600-B</b> Metal Brake Line 10.25", Each</p> 	<p><b>113 611 781D</b> <b>98-9614-B</b> Steel Brake Line, 13" Length, Type 1 All, Each</p> 
<p><b>211 611 701</b> <b>98-6703-B</b> Brake Hose, Front, Type 1 65-66, Ghia 65-66, Type 2 56-67, Each</p> 	<p><b>113 611 763A</b> <b>98-9612-B</b> Steel Brake Line, 8" Length, Type 1 All, Each</p> 	<p><b>113 611 781E</b> <b>98-9615-B</b> Steel Brake Line, 17" Length, Type 1 All, Each</p> 
<p><b>311 611 701B</b> <b>98-6704-B</b> Brake Hose, Front, w/Disc Brakes, Type 1 67-77, Ghia 67-74, Type 3 67-73, Each</p> 	<p><b>113 611 764B</b> <b>98-9618-B</b> Steel Brake Line, 25" Length, Type 1 All, Each</p> 	<p><b>113 611 817</b> <b>98-6683-B</b> Grommet, Master Cylinder, Type 1 50-66, Each</p> 

# REPLACEMENT PARTS



<p><b>211 611 817A</b> <b>98-6684-B</b> Grommet, Master Cylinder, Type 1 67-79, Type 2 67-79, Each</p> 	<p><b>251 698 151A</b> <b>18-1013-0</b> Front Brake Pads, Type 2 73-79, Vanagon 80-85, Set</p> 	<p><b>131 698 700</b> <b>98-6993-B</b> Metal Brake Line Kit, Type 1 69-77</p> 
<p><b>211 615 107/108</b> <b>18-1011-0</b> Front Brake Caliper w/ Pads and Bolts, Type 2 73-79, Vanagon 80-85, Each Fits Left &amp; Right</p> 	<p><b>131 698 237C</b> <b>98-6987-B</b> Brake Hardware Kit, Front, Type 1 65-77</p> 	<p><b>111 701 059Q</b> <b>00-3550-0</b> Front Floor Panel, w/o Seat Rails, Left</p> 
<p><b>311 615 107/8</b> <b>98-1150-B</b> Universal Brake Caliper, L or R, Supplied with Pads, Each</p> 	<p><b>113 698 237D</b> <b>98-6986-B</b> Brake Hardware Kit, Front, Type 1 58-64</p> 	<p><b>111 701 060Q</b> <b>00-3551-0</b> Front Floor Panel, w/o Seat Rails, Right</p> 
<p><b>211 615 301B</b> <b>18-1014-0</b> Brake Rotor, Front, Type 2 73-79, Each</p> 	<p><b>113 698 237H</b> <b>98-6988-B •</b> Brake Hardware Kit, S/B, Front , Type 1 71-79</p> 	<p><b>112 701 063Q</b> <b>00-3552-0</b> Rear Floor Panel, Left</p> 
<p><b>113 615 601</b> <b>22-2841-B</b> Brake Rotor, 4/130, I.R.S., 68-on, Each</p> 	<p><b>113 698 537B</b> <b>98-6989-B •</b> Brake Hardware Kit, Rear, Type 1 58-66, Ghia 58-66</p> 	<p><b>112 701 064Q</b> <b>00-3553-0</b> Rear Floor Panel, w/ Battery Bracket, Right</p> 
<p><b>113 615 601S</b> <b>22-2842-B</b> Brake Rotor, 4/130, Swing Axle, thru 68, Each</p> 	<p><b>113 698 537C</b> <b>98-6990-B •</b> Brake Hardware Kit, Rear, Type 1 67-79, Ghia 67-74</p> 	<p><b>111 701 255B</b> <b>98-7011-B •</b> Shift Guide, Type 1 60-79, Ghia 60-74, Type 2 60-65, Each</p> 
<p><b>311 698 071</b> <b>98-6881-B</b> Brake Shoe Hardware Kit, (1 Wheel), Type 1 65-79, Ghia 65-74</p> 	<p><b>111 698 700</b> <b>98-6991-B</b> Metal Brake Line Kit, Type 1 thru 66</p> 	<p><b>111 701 259A</b> <b>98-2038-B •</b> Shift Guide Bushing, Type 1 60-79, Ghia 60-74, Type 2 60-65, Type 3 64-73, Each</p> 
<p><b>111 698 131</b> <b>98-6982-B</b> Repair Kit, Hubcap Spring w/Rivet, Type 1 50-65, Ghia 56-65, Type 2 50-67</p> 	<p><b>113 698 700</b> <b>98-6992-B</b> Metal Brake Line Kit, Type 1 67-68</p> 	<p><b>111 701 263</b> <b>98-7013-B •</b> Locking Ring for Shift Guide Bushing, Each</p> 





# REPLACEMENT PARTS

<p><b>113 701 605</b> <b>00-3157-B •</b> Floor Pan Seal, Type 1 thru 79, Ghia 56-74, Type 3 64-73</p> 	<p><b>111 707 155</b> <b>00-3173-B •</b> Bumper Guard, Euro Style, Type 1 52-67, Each</p> 	<p><b>113 707 311A</b> <b>98-1018-B</b> Bumper Blade, Rear, Euro-Style, Type 1 52-67, Each</p>  <p><b>Shipped by Truck Only</b></p>
<p><b>113 707 103D</b> <b>98-1006-B</b> Bumper, Front, Type 1 68-73, Each</p>  <p><b>Shipped by Truck Only</b></p>	<p><b>113 707 191B</b> <b>98-1013-B •</b> Bumper Bolt, Long (Bag of 12), Type 1 52-67</p> 	<p><b>113 707 333A</b> <b>98-1019-B •</b> Bumper Bracket, Left Rear, Type 1 68-73, Each</p> 
<p><b>113 707 103DM</b> <b>98-1007-B</b> Bumper, Front, w/Turn Signal Cut Outs, Type 1 68-73, Each</p>  <p><b>Shipped by Truck Only</b></p>	<p><b>113 707 191C</b> <b>98-1014-B •</b> Bumper Bolt, Short (Bag of 12), Type 1 68-73, Ghia 56-74, Type 3 71-74</p> 	<p><b>113 707 334A</b> <b>98-1020-B •</b> Bumper Bracket, Right Rear, Type 1 68-73, Each</p> 
<p><b>113 707 111A</b> <b>98-1008-B</b> Bumper Blade, Front, Euro Style, Type 1 52-67, Each</p>  <p><b>Shipped by Truck Only</b></p>	<p><b>111 707 197A</b> <b>00-3178-B •</b> Grommet, Bumper Bracket, Type 1 50-67, Each</p> 	<p><b>111 707 335B/6B</b> <b>98-1021-B •</b> Bumper Bracket, L &amp; R Rear, Black, Type 1 50-67, Each</p> 
<p><b>111 707 121</b> <b>98-1078-B •</b> Bumper Reinforcement, Type 1 52-67, Each</p> 	<p><b>111 707 197B</b> <b>00-3179-B •</b> Grommet, Bumper Bracket (Exc. 71-73 S/B Front), Type 1 68-73, Each</p> 	<p><b>113 707 391/2</b> <b>98-1022-B •</b> Bumper Support, L &amp; R Rear, Black, Type 1 55-67, Each</p> 
<p><b>113 707 133A</b> <b>98-1009-B •</b> Bumper Bracket, Left Front, Type 1 68-73, Each</p> 	<p><b>111 707 199A</b> <b>98-1015-B •</b> Grommet, Bumper Support, Type 1 55-67, Each</p> 	<p><b>113 711 115A</b> <b>98-9981-B •</b> Universal Gear Shifter Boot, Type 1 49-79, Type 2 60-71,</p> 
<p><b>113 707 134A</b> <b>98-1010-B •</b> Bumper Bracket, Right Front, Type 1 68-73, Each</p> 	<p><b>113 707 233/4</b> <b>98-1016-B •</b> Bumper Support, L &amp; R Front, Black, Type 1 55-67, Each</p> 	<p><b>211 711 149</b> <b>00-4456-B •</b> Reverse Lock Out Plate (Exc. Autostick), Type 1 50-72, Ghia 56-72, Type 2 55-71, Each</p> 
<p><b>111 707 135A/6A</b> <b>98-1011-B •</b> Bumper Bracket, Front L &amp; R, Black, Type 1 50-67, Each</p> 	<p><b>113 707 303C</b> <b>98-1017-B</b> Bumper,Rear,Type 1 68-73, Each</p>  <p><b>Shipped by Truck Only</b></p>	<p><b>111 711 175B</b> <b>98-1079-B •</b> Shift Rod Coupler, Type 1 50-64, Ghia 56-64, Type 2 55-67, Each</p> 

# REPLACEMENT PARTS



<p><b>211 711 189A</b> <b>98-1026-2 •</b> Grub Screw for Shift Rod Coupler, Type 1 50-64, Ghia 56-64, Type 2 55-67, Each</p> 	<p><b>211 721 163A</b> <b>98-7067-B</b> Return Spring, Brake Pedal, Type 2 55-67, Each</p> 	<p><b>211 721 335J</b> <b>98-7205-B</b> Clutch Cable, Type 2 72-79, Each</p> 
<p><b>311 711 461</b> <b>00-4483-B •</b> Emergency Brake Boot Type 1 65-79, Ghia 65-74, Type 3 66-73, Each</p> 	<p><b>311 721 173A</b> <b>00-9904-B •</b> Pedal Pad, Clutch &amp; Brake, Type 1 50-79, Ghia 56-74, Type 2 55-67, Vanagon 80-92, Type 3 66-73, Each</p> 	<p><b>131 721 349</b> <b>98-7012-B •</b> Clutch Adjustment Wing Nut, Type 1 50-79, Ghia 56-74, Type 2 50-79, Type 3 64-73, Each</p> 
<p><b>211 711 629B</b> <b>98-7033-B</b> Heater Cable, Type 2 50-67, Each</p> 	<p><b>113 721 231E</b> <b>98-7074-B</b> Brake Pedal Stop Plate, Type 1 50-79, Ghia 58-74, Type 3 64-73, Each</p> 	<p><b>211 721 351</b> <b>98-7081-B</b> Clevis Pin, Clutch Cable, Type 2 55-71, Each</p> 
<p><b>211 711 630L</b> <b>98-7038-B</b> Heater Cable, Right, Type 2 1972, Each</p> 	<p><b>111 721 305B</b> <b>98-7075-B</b> Clutch Pedal Shaft (Original German Style), Type 1 72-79, Each</p>  <p style="text-align: right;">Face</p>	<p><b>311 721 361</b> <b>98-7208-B</b> Bowden Tube, Type 1 52-79, Ghia 56-74, Type 2 52-67, Type 3 64-73, Each</p> 
<p><b>211 711 630N</b> <b>98-7039-B</b> Heater Cable, Right, Type 2 73-79, Each</p> 	<p><b>113 721 305B</b> <b>98-7077-B</b> Shaft, Clutch Pedal, Type 1 65-71, Ghia 65-71, Type 3 65-71, Each</p>  <p style="text-align: right;">Face</p>	<p><b>211 721 387</b> <b>98-7086-B</b> Dust Seal, Accel Rod/Pedal, Type 2 55-79, Each</p> 
<p><b>113 711 691</b> <b>98-7022-B</b> Dust Boot, Heater Cable, Type 1 50-79, Ghia 56-74, Type 3 64-73, Each</p> 	<p><b>111 721 335</b> <b>98-7200-B</b> Clutch Cable, Type 1 thru 60/62-63, Ghia thru 60/62-63, Each</p> 	<p><b>113 721 551</b> <b>98-7083-B</b> Protective Tube, Accelerator Cable (598mm), Type 1 56-79, Ghia 56-74, Each</p> 
<p><b>111 711 713A</b> <b>98-7056-B</b> Heater Cable, Rear Footwell, Type 1 73-79, Each</p> 	<p><b>113 721 335A</b> <b>98-7203-B</b> Clutch Cable, Type 1 64-71, Ghia 64-71, Each</p> 	<p><b>111 721 555C</b> <b>98-7500-B</b> Accelerator Cable, Type 1 58-65, Ghia 58-65, Each</p> 
<p><b>131 721 163</b> <b>98-7190-B</b> Return Spring, Brake Pedal, Type 1 67-79, Ghia 67-74, Type 3 65-73, Each</p> 	<p><b>111 721 335C</b> <b>98-7201-B</b> Clutch Cable, Type 1 72-74, Ghia 72-74, Each</p> 	<p><b>111 721 555E</b> <b>98-7501-B</b> Accelerator Cable, Type 1 66-71, Ghia 66-71, Each</p> 













# REPLACEMENT PARTS

<p><b>111 721 555J</b> <b>98-7502-B</b> Accelerator Cable, Type 1 72-74, Ghia 72-74, Each</p> 	<p><b>211 798 200</b> <b>98-7096-B</b> Shift Bushing Repair Kit, All Bushings Necessary, Type 2 54-79, Vanagon 80-93</p> 	<p><b>111 813 705D</b> <b>00-3592-B •</b> Engine Compartment Seal, Type 1 67-74, Ghia 67-74, Each</p> 
<p><b>113 721 647A</b> <b>98-1072-B •</b> Pedal Pad, Accelerator, Type 1 58-79, Ghia 58-74, Type 3 65-73, Each</p> 	<p><b>311 798 211</b> <b>16-5103-0 •</b> Shift Rod Coupling Assembly Kit, w/ Urethane Inserts, Type 1 65-79, Ghia 65-74, Type 2 68-79, Type 3 64-73</p> 	<p><b>111 813 741G</b> <b>98-8133-B</b> Seal, Bell Housing, Type 1 50-79, Ghia 56-74, Type 2 55-71</p> 
<p><b>113 798 053A</b> <b>98-1023-B</b> Bumper Assembly, Type 1 55-67, Each <b>Shipped by Truck Only</b></p> 	<p><b>113 798 305</b> <b>00-4548-B •</b> Emergency Brake Assembly Kit, Black, Type 1 56-79, Ghia 56-74</p> 	<p><b>113 819 447A/8A</b> <b>98-1028-B •</b> Quarter Grills, Black Plastic, Type 1 71-77, Pair</p> 
<p><b>113 798 073B</b> <b>98-1024-B</b> Bumper Assembly, Type 1 55-67, Each <b>Shipped by Truck Only</b></p> 	<p><b>113 798 305CH</b> <b>00-4549-B •</b> Emergency Brake Assembly Kit, Chrome, Type 1 56-79, Ghia 56-74</p> 	<p><b>113-819-447C/8C</b> <b>98-9982-B •</b> Chrome Quarter Vent Grilles, Type 1 71 &amp; Later, Pair</p> 
<p><b>113 798 074</b> <b>98-7090-B</b> Repair Kit, Accelerator Pedal, Type 1 67-79, Ghia 67-74, Type 3 64-73</p> 	<p><b>113 798 507B</b> <b>98-1027-B •</b> Accelerator Pedal Kit, Type 1 67-79, Ghia 66-74, Type 3 64-73</p> 	<p><b>113 821 509MHD</b> <b>00-6831-B</b> Running Board with 16mm Molding L &amp; R, Pair, Type 1 50-79 Sold in pairs only</p> 
<p><b>113 798 078</b> <b>98-7088-B</b> Repair Kit, Accelerator Pedal, Type 1 58-66, Ghia 58-66</p> 	<p><b>113 798 900</b> <b>00-4526-B</b> Pedal Assembly, Clutch &amp; Brake, Type 1 65-72, Ghia 65-72, Type 3 64-73 <b>Upgraded with Zerk Fitting</b> <b>See page 294</b></p> 	<p><b>111 821 715A</b> <b>00-3003-B •</b> Fender Beading, 2 pcs., Type 1 50-79</p> 
<p><b>113 798 121</b> <b>98-1025-B •</b> Gear Shift Assembly Kit, Type 1 56-67, Ghia 56-67</p> 	<p><b>111 807 115</b> <b>98-1005-B •</b> Bumper Bracket for 113 707 103DM, Type 1 68-73, Each</p> 	<p><b>113 823 355</b> <b>98-8211-B</b> Cover, Front Hood Spring, Each, Type 1 62-77</p> 
<p><b>113 798 121A</b> <b>98-7095-B •</b> Stock Shifter Assembly Kit, Straight, Type 1 68-on, Ghia 68-74, Each</p> 	<p><b>111 813 705A</b> <b>00-3591-B •</b> Engine Compartment, Seal, Type 1 50-66, Ghia 56-66, Type 2 55-71, Each</p> 	<p><b>111 823 461</b> <b>98-8214-B</b> Finger Pull, Fuel Door Release, Type 1 69-72, Ghia 69-74, Each</p> 

(•) Also available in skinpack **491**



















# REPLACEMENT PARTS



<p><b>171 823 499</b> <b>98-8212-B</b> Rubber Stop, Decklid, Type 1 67-79, Each</p> 	<p><b>133 823 731</b> <b>00-3588-B •</b> Front Hood Seal, Super Beetle, Type 1 73-79, Each</p> 	<p><b>111 831 421</b> <b>98-2101-B •</b> Door Hinge Pin for Mirror, Type 1 50-67, Each</p> 
<p><b>111 823 507A</b> <b>98-1080-B •</b> Hood Lock, Upper, Type 1 50-67, Each</p> 	<p><b>113 823 731B</b> <b>00-3590-B •</b> Front Hood Seal, Type 1 50-77, Each</p> 	<p><b>311 831 439A</b> <b>98-2043-B •</b> Cap, for Door Hinge, Type 1 68-79, Type 2 68-79, Each</p> 
<p><b>111 823 507F</b> <b>98-1081-B •</b> Hood Lock, Upper, Type 1 68-79, Each</p> 	<p><b>111 827 171</b> <b>16-9837-7 •</b> Decklid Hinge Bracket, M6-1.0 Threaded Type 1 50-79, Each</p> 	<p><b>111 831 449A</b> <b>98-2042-B •</b> Cap, for Door Hinge Screw, Type 1 50-79, Each</p> 
<p><b>111 823 509B</b> <b>98-1030-B •</b> Hood Lock, Lower, Type 1 50-67, Each</p> 	<p><b>113 827 503A</b> <b>98-1084-B •</b> Lock, Deck Lid, Type 1 65-66, Each</p>  <p><b>NEW!</b></p>	<p><b>111 831 721A/2A</b> <b>00-3593-B •</b> Weatherstrip, L &amp; R Door, Type 1 56-66, Pair</p> 
<p><b>152 823 509B</b> <b>98-1031-B •</b> Hood Lock, Lower, Type 1 69-79, Each</p> 	<p><b>113 827 503F</b> <b>98-1034-B •</b> Lock, Deck Lid, Type 1 67-71, Type 2 67, Each</p> 	<p><b>111 831 721D/2D</b> <b>00-3594-B •</b> Weatherstrip, L &amp; R Door, Type 1 67-77, Pair</p> 
<p><b>113 823 565A</b> <b>98-1032-B •</b> Hood Handle, Type 1 52-67, Each</p> 	<p><b>113 827 503H</b> <b>98-1035-B •</b> Lock, Deck Lid, Type 1 72-79, Each</p> 	<p><b>211 831 721D/2D</b> <b>00-3597-B •</b> Weatherstrip, L &amp; R Door, Type 2 68-79, Pair</p> 
<p><b>113 823 565F</b> <b>98-1033-B •</b> Hood Handle, Type 1 68-79, Each</p> 	<p><b>113 827 571D</b> <b>98-1090-B •</b> Lock, Deck Lid, "T" Handle, Type 1 52-64, Each</p> 	<p><b>111 837 021B</b> <b>98-8313-B</b> Door Release Mechanism, Left, Type 1 56-64, Each</p> 
<p><b>113 823 579A</b> <b>98-2044-B •</b> Seal Set, Hood Handle (1-Large, 1-Small), Type 1 68-79</p> 	<p><b>111 827 705</b> <b>00-3598-B •</b> Deck Lid Seal, Type 1 50-79, Each</p> 	<p><b>111 837 022B</b> <b>98-8314-B</b> Door Release Mechanism, Right, Type 1 56-64, Each</p> 





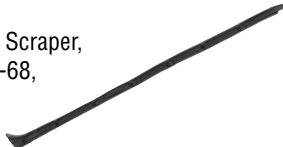









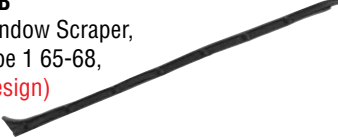











# REPLACEMENT PARTS

<p><b>111 837 035B</b> <b>98-8321-B</b> Striker Plate, Left, Type 1 60-64, Each</p> 	<p><b>111 837 211A</b> <b>98-2046-B •</b> Seal Set, Outside Door Handle (2-Large, 2-Small), Type 1 60-65</p> 	<p><b>111 837 267A</b> <b>98-2036-B •</b> Seal, Door Check Rod, Type 1 56-79, Each</p> 
<p><b>151 837 035C</b> <b>98-8322-B</b> Striker Plate, Left, Type 1 68-77, Type 3 67-73, Each</p> 	<p><b>211 837 211A</b> <b>98-8337-B</b> Seal Set, Outer Door Handle (2-Large, 2-Small), Type 2 69-79</p> 	<p><b>111 837 361</b> <b>98-8345-B</b> Felt Channel Clips, Type 1 50-79, Ghia 56-74, Type 2 50-79, Type 3 64-73, Each</p> 
<p><b>111 837 036B</b> <b>98-8323-B</b> Striker Plate, Right, Type 1 60-64, Each</p> 	<p><b>111 837 211C</b> <b>98-2048-B •</b> Seal Set, Outside Door Handle (2-Large, 2-Small), Type 1 68-79, Ghia 68-74, Type 3 68-73</p> 	<p><b>311 837 433</b> <b>98-2089-B</b> Felt Window Channel, (Back of Vent Post), Type 1 52-64, Each</p> 
<p><b>151 837 036C</b> <b>98-8324-B</b> Striker Plate, Right, Type 1 68-77, Type 3 67-73, Each</p> 	<p><b>113 837 225A</b> <b>98-1039-B •</b> Door Handle, Inner, Type 1 56-66, Ghia 56-63, Each</p> 	<p><b>311 837 433A</b> <b>98-2090-B</b> Felt Window Channel, (Back of Vent Post), Type 1 65-77, Type 2 68-79, Type 3 64-73, Each</p> 
<p><b>191 837 187</b> <b>98-2092-B •</b> Knob, Interior Door Lock, Most Water Cooled Models, Each</p> 	<p><b>111 837 229C</b> <b>98-8338-B •</b> Door/Window Handle Tension Spring, Type 1 All, Each</p> 	<p><b>111 837 439D</b> <b>00-9771-B</b> Felt Window Channel, Rear &amp; Top, Type 1 52-77, Type 2 68-79, Type 3 64-73, Pair</p> 
<p><b>111 837 187B</b> <b>98-2091-B •</b> Knob, Interior Door Lock, Type 1 67-79, Ghia 67-71, Type 2 68-79, Type 3 64-73, Each</p> 	<p><b>113 837 235A</b> <b>98-2040-B •</b> Buffer, Window Handle, Black, Type 1 56-67, Ghia 56-67, Each</p> 	<p><b>241 837 465</b> <b>98-3730-B</b> Vent Window Post Seal, Type 1 65-77, Type 2 68-79, Type 3 64-73, Each</p> 
<p><b>113 837 205M</b> <b>98-1038-B •</b> Door Handle, Outer, Type 1 68-79, Ghia 68-74, Each</p> 	<p><b>111 837 235AIV</b> <b>98-2041-B •</b> Buffer, Window Handle, Ivory, Type 1 56-67, Ghia 56-67, Each</p> 	<p><b>111 837 475</b> <b>98-1085-B</b> Inside Window Scraper, L or R, Type 1 52-64, Each</p> 
<p><b>211 837 205N</b> <b>98-8334-B</b> Door Handle, Left or Right, Type 2 69-79, Each</p> 	<p><b>113 837 239BC</b> <b>98-8340-B</b> Escutcheon, Chrome Plated Plastic, Door Pull, Type 1 67-79, Ghia 64-74, Type 2 68 79, Type 3 64-73, Each</p> 	<p><b>111 837 475A</b> <b>98-2061-B</b> Inside Window Scraper, Left, Type 1 65-68, (7 Clip Design) Each</p> 

(•) Also available in skinpack **493**

























# REPLACEMENT PARTS



<p><b>111 837 475B</b> <b>98-2063-B</b> Inside Window Scraper, Left, Type 1 69-77, (4 Clip Design) Each</p> 	<p><b>113 837 581EB</b> <b>98-1070-B •</b> Window Handle, Black, Type 1 56-67, Ghia 56-67, Each</p> 	<p><b>113 837 640A</b> <b>98-1044-B •</b> Vent Window Lock, Right, Type 1 52-64, Each</p> 
<p><b>111 837 476A</b> <b>98-2062-B</b> Inside Window Scraper, Right, Type 1 65-68, (7 Clip Design) Each</p> 	<p><b>111 837 581J</b> <b>98-1042-B •</b> Window Crank, H.D., Black, Type 1 68-74, Ghia 68-74, Type 2 68-79, Type 3 68-73, Each</p> 	<p><b>111 837 657A</b> <b>98-1045-B •</b> Vent Window Lock, Left (Exc. Convertible), Type 1 68-77, Each</p> 
<p><b>111 837 476B</b> <b>98-2064-B</b> Inside Window Scraper, Right, Type 1 69-77, (4 Clip Design) Each</p> 	<p><b>111 837 595A</b> <b>98-8364-B</b> Escutcheon, Window Crank, Type 1 68-79, Ghia 68-74, Type 2 68-79, Type 3 68-73, Each</p> 	<p><b>111 837 658A</b> <b>98-1046-B •</b> Vent Window Lock, Right (Exc. Convertible), Type 1 68-77, Each</p> 
<p><b>111 837 501F</b> <b>00-9757-B</b> Window Regulator, Left, Type 1 65-67, Each </p> 	<p><b>111 837 625</b> <b>98-1086-B •</b> Vent Window Seal, Left (Exc. Convertible), Type 1 52-64, Each</p> 	<p><b>211 841 641AC</b> <b>98-8376-B</b> Door Handle, Inner, Chrome, Type 2 50-67, Each</p> 
<p><b>111 837 502F</b> <b>00-9758-B</b> Window Regulator, Right, Type 1 65-67, Each </p> 	<p><b>111 837 625B</b> <b>98-2007-B •</b> Vent Window Seal, Left (Exc. Convertible), Type 1 65-77, Each</p> 	<p><b>113 845 121J</b> <b>98-4531-B</b> Windshield Seal (Exc. Super Beetle, 73-on), Type 1 65-77, Each</p> 
<p><b>111 837 571G</b> <b>98-8366-B</b> Lift Channel, Door Window, Type 1 68-77, Each</p> 	<p><b>111 837 626</b> <b>98-1087-B •</b> Vent Window Seal, Right (Exc. Convertible), Type 1 52-64, Each</p> 	<p><b>113 845 321D</b> <b>98-4535-B</b> Quarter Window Seal, Left or Right, Type 1 65-77, Each</p> 
<p><b>321 837 581</b> <b>98-1041-B •</b> Window Handle, Black, Type 1 75-79, Vanagon 80-91, Each</p> 	<p><b>111 837 626B</b> <b>98-2008-B •</b> Vent Window Seal, Right (Exc. Convertible), Type 1 65-77, Each</p> 	<p><b>113 845 521J</b> <b>98-4554-B</b> Rear Window Seal, Type 1 65-71, Each</p> 
<p><b>113 837 581E</b> <b>98-1069-B •</b> Window Handle, Ivory, Type 1 56-67, Ghia 56-67, Each</p> 	<p><b>113 837 639A</b> <b>98-1043-B •</b> Vent Window Lock, Left, Type 1 52-64, Each</p> 	<p><b>113 847 135A</b> <b>98-4714-B</b> Quarter Window Seal Outer for Pop-Out Windows, L &amp; R, Type 1 65-77, Each</p> 



# REPLACEMENT PARTS

<p><b>113 853 321A</b> <b>98-1047-B</b> Trim Frame w/Scraper, Left, Type 1 52-64, Each </p> 	<p><b>111 853 695</b> <b>98-8393-B •</b> Clip/Retainer, Decklid Script, Type 1 67-74, Each</p> 	<p><b>111 857 101K</b> <b>00-3583-B</b> Glove Box(Exc. 73 on Super Beetle), Type 1 68-77, Each</p> 
<p><b>113 853 321D</b> <b>98-1048-B</b> Trim Frame w/Scraper, Left, Type 1 65-77, Each </p> 	<p><b>113 857 051A</b> <b>00-4435-0</b> Replacement Dash, Bug, 68-70</p> 	<p><b>133 857 131</b> <b>98-1054-B •</b> Lock, Glove Box (Exc. 73-on Super Beetle), Type 1 68-77, Ghia 68-74, Type 2 68-71, Type 3 68-73, Each</p> 
<p><b>113 853 322A</b> <b>98-1049-B</b> Trim Frame w/Scraper, Right, Type 1 52-64, Each </p> 	<p><b>113 857 051DS</b> <b>00-4436-0</b> Replacement Dash, Bug, 71-76, 71-72 S/B</p> 	<p><b>113 857 219A</b> <b>00-4847-B •</b> Boot for 113 853 585B Molding Clip (Bag of 100), Type 1 52-66, Type 3 64-66</p> 
<p><b>113 853 322D</b> <b>98-1050-B</b> Trim Frame w/Scraper, Right, Type 1 65-77, Each </p> 	<p><b>211 857 101A</b> <b>00-3584-B</b> Glove Box, Type 2 68-79, Each</p> 	<p><b>141 857 501</b> <b>98-9974-B •</b> Mirror, Outside, Ghia 66 &amp; Later, Left, Ea</p> 
<p><b>113 853 585B</b> <b>98-1051-B •</b> Body Side Molding Clip, Metal (Bag of 100), Type 1 52-66, Type 3 64-66</p> 	<p><b>141 857 101C</b> <b>00-3564-B</b> Glove Box, Ghia 56-74, Each</p> 	<p><b>141 857 502</b> <b>98-9975-B •</b> Mirror, Outside, Ghia 66 &amp; Later, Right, Ea</p> 
<p><b>113 853 585C</b> <b>98-1052-B •</b> Body Side Molding Clip, Plastic (Bag of 100), Type 1 67-79, Type 3 67-73</p> 	<p><b>111 857 101D</b> <b>00-3580-B</b> Glove Box, Type 1 52-57, Each</p> 	<p><b>98-9976-B •</b> Mirror, Outside, Type 2 67 &amp; Earlier, Left, Each</p> 
<p><b>113 853 615</b> <b>98-8392-B</b> Seal/Retainer, Emblem, Type 1 60-77, Each</p> 	<p><b>111 857 101F</b> <b>00-3581-B</b> Glove Box, Type 1 58-64, Each</p> 	<p><b>98-9977-B •</b> Mirror, Outside, Type 2 67 &amp; Earlier, Right, Each</p> 
<p><b>113 853 641A</b> <b>98-1053-B •</b> Horn Grill, Type 1 52-67, Each</p> 	<p><b>111 857 101H</b> <b>00-3582-B</b> Glove Box, Type 1 65-67, Each</p> 	<p><b>151 857 501</b> <b>98-8571-B •</b> Mirror, Outside, Convertible, Type 1 68-79, Left, Each</p> 

(•) Also available in skinpack **495**

# REPLACEMENT PARTS



<p><b>151 857 502</b> <b>98-8572-B •</b> Mirror, Outside, Right, Convertible, Type 1 68-79, Each</p> 	<p><b>113 857 514A</b> <b>98-2014-B •</b> Mirror, Outside, Right, Type 1 50-67, Each</p> 	<p><b>133 857 561W</b> <b>00-4427-B •</b> Clip, Sunvisor, White, Pair, Type 1 68-79, Ghia 68-74, Type 3 68-73</p> 
<p><b>113 857 511</b> <b>98-8577-B •</b> Rear View Mirror, Type 1 Sedan, thru 57, Chrome Plated Metal, Each</p> 	<p><b>113 857 514ATD</b> <b>98-8582-B •</b> Mirror, Outside Right, Oval, Type 1 thru 67, Each</p>  <p><b>Use P/N: 98-2101 Threaded Door Hinge Pin</b></p>	<p><b>113 857 611B</b> <b>98-2093-B •</b> Assist Strap, Interior, Black, Type 1 58-67, Each</p> 
<p><b>113 857 511A</b> <b>98-8580-B •</b> Rear View Mirror, O.E. Style, Type 1 Sedan, 58-64, Chrome Plated Metal, Each</p> 	<p><b>113 857 514D</b> <b>98-2016-B •</b> Mirror, Outside Right, Sedan, Type 1 68-77, Each</p> 	<p><b>113 857 611BW</b> <b>98-2094-B •</b> Assist Strap, Interior, White, Type 1 58-67, Each</p> 
<p><b>111 857 511B</b> <b>98-8578-B •</b> Rear View Mirror, O.E. Style, Type 1 Sedan, 65-67, Chrome Plated Metal, Each</p> 	<p><b>211 857 514F</b> <b>98-2018-B •</b> Mirror, Outside, Right, Type 2 68-79, Each</p> 	<p><b>113 857 611E</b> <b>98-2095-B •</b> Assist Strap, Interior, Black, Type 1 68-77, Each</p> 
<p><b>113 857 513A</b> <b>98-2013-B •</b> Mirror, Outside, Left, Type 1 50-67, Each</p> 	<p><b>ZVW 151 201</b> <b>98-8573-B •</b> Mirror, Outside, L or R, Type 2 55-67, Each</p> 	<p><b>113 857 611EW</b> <b>98-2096-B •</b> Assist Strap, Interior, White, Type 1 68-77, Each</p> 
<p><b>113 857 513ATD</b> <b>98-8581-B •</b> Mirror, Outside Left, Oval, Type 1 thru 67, Each</p>  <p><b>Use P/N: 98-2101 Threaded Door Hinge Pin</b></p>	<p><b>111 857 561B</b> <b>00-4430-B •</b> Clip, Sunvisor, Black, Pair, Type 1 65-67, Ghia 65-67, Type 2 68-79</p> 	<p><b>113 857 637A</b> <b>98-2097-B •</b> Coat Hook, Black, Type 1 61-67, Each</p> 
<p><b>113 857 513D</b> <b>98-2015-B •</b> Mirror, Outside, Left, Sedan, Type 1 68-77, Each</p> 	<p><b>133 857 561B</b> <b>00-4428-B •</b> Clip, Sunvisor, Black, Pair, Type 1 68-79, Ghia 68-74, Type 3 68-73</p> 	<p><b>113 857 637AW</b> <b>98-2098-B •</b> Coat Hook, White, Type 1 61-67, Each</p> 
<p><b>211 857 513F</b> <b>98-2017-B •</b> Mirror, Outside, Left, Type 2 68-79, Each</p> 	<p><b>111 857 561W</b> <b>00-4429-B •</b> Clip, Sunvisor, White, Pair, Type 1 65-67, Ghia 65-67, Type 2 68-79</p> 	<p><b>113 857 637B</b> <b>98-2099-B •</b> Coat Hook, Black, Type 1 68-77, Type 3 68-73, Each</p> 





# REPLACEMENT PARTS

<p><b>113 857 637BW</b> <b>98-2100-B •</b> Coat Hook, White, Type 1 68-77, Type 3 68-73, Each</p> 	<p><b>113 863 515C</b> <b>00-3570-B</b> Wiring Cover, Type 1 56-67, Each</p> 	<p><b>111 898 213</b> <b>98-8972-B</b> Guide Piece Kit (6 pcs. Set), Seat Rails, Type 1 73-79</p> 
<p><b>113 857 723A</b> <b>98-8411-B</b> Hook, Safety Belt, Black, Type 1 68-72, Type 2 68-79, Type 3 67-73, Each</p> 	<p><b>141 863 515C</b> <b>00-3565-B</b> Wiring Cover, Ghia 56-74, Each</p> 	<p><b>151 898 235</b> <b>98-9973-B</b> Molding Clip, Type 1 50-64, Convertible (Bag of 100)</p> 
<p><b>211 863 341</b> <b>00-9958-B •</b> E-Brake Boot, Grey, Type 2 50-79</p> <p><b>NEW!</b></p> 	<p><b>113 863 515H</b> <b>00-3571-B</b> Wiring Cover (Exc. Super Beetle), Type 1 68-77, Each</p> 	<p><b>113 898 376A</b> <b>98-8973-B</b> Kick Panel Set, Left/Right, Black, Type 1 63-77, 2 Pcs.</p> 
<p><b>111 863 341A</b> <b>00-9954-B •</b> E-Brake Boot, Black, Type 1 55-57</p> 	<p><b>111 898 061</b> <b>00-3554-B •</b> Bolts and Pan Washers for one pan half, Set.</p> 	<p><b>371 898 607</b> <b>98-8975-B</b> Kit, Seat Back Release Knob (Set for 1 Seat), Type 1 68-79, Ghia 68-74, Type 3 68-73</p> 
<p><b>311 863 341A</b> <b>00-9952-B •</b> Emergency Brake Boot, Type 1 56-64, Ghia 56-64, Each</p> 	<p><b>113 898 111</b> <b>98-1059-B</b> Molding Kit (111 898 111C), Type 1 68-72, Boxed Kit</p> 	<p><b>151 898 641C</b> <b>98-1061-B •</b> Dash Grab Handle Kit, Black, Type 1 61-67, Each</p> 
<p><b>211 863 341B</b> <b>00-9959-B •</b> E-Brake Boot, Black, Type 2 50-79</p> <p><b>NEW!</b></p> 	<p><b>111 898 111A</b> <b>98-1060-B</b> Molding Kit, Type 1 63-66, Boxed Kit</p> 	<p><b>113 898 740</b> <b>98-2012-B</b> Floor Sound Absorber Kit, Tar Boards, Set of 4, Type 1 56-72</p> 
<p><b>113 863 509C</b> <b>98-1082-B</b> Trunk Liner, Type 1 61-67, Each</p>  <p><b>ups+</b></p>	<p><b>113 898 205C</b> <b>98-2032-B •</b> Door Handle Set, Keyed Alike, Type 1 60-64, Pair</p> 	<p><b>113 898 805HD</b> <b>98-1062-B</b> Engine Comp Firewall Insulation Kit, Type 1 53-79, 3 Pcs. 5.0mm Thick</p> 
<p><b>113 863 509F</b> <b>98-1083-B</b> Trunk Liner (Exc. Super Beetle), Type 1 68-77, Each</p>  <p><b>ups+</b></p>	<p><b>113 898 205M</b> <b>98-2034-B •</b> Door Handle Set, Keyed Alike, Type 1 68-79, Ghia 68-74, Pair</p> 	<p><b>211 898 825</b> <b>98-8976-B</b> Seat Clamp Kit, Middle Seat to Floor, Type 2 52-72</p> 

(•) Also available in skinpack **497**







# REPLACEMENT PARTS



<p><b>211 898 825A</b> <b>98-8977-B</b> Seat Clamp Kit, Rear Seat to Floor, Type 2 52-72</p> 	<p><b>111 903 137D</b> <b>00-9928-B •</b> Fan Belt, 9.5 x 905mm, 12-Volt, Type 1 67-79, Ghia 67-74, Type 2 67-71, Each</p> 	<p><b>113 905 853</b> <b>98-9023-B</b> Ignition Lock Cylinder, w/Keys, Type 1 68-70, Ghia 68-70, Type 3 68-70, Each</p> 
<p><b>111 899 115A</b> <b>98-8994-B</b> Rubber Pad, Body Mounting (17mm), Lower, Type 1 53-77, Each</p> 	<p><b>113 903 141B</b> <b>00-9058-B •</b> Generator/Alternator Strap, Type 1 67-79, Ghia 67-74, Type 2 67-71, Each</p> 	<p><b>311 905 865A</b> <b>98-2053-B •</b> Ignition Switch, Electrical, Type 1 68-70, Ghia 68-70, Type 2 68-70, Type 3 68-70, Each</p> 
<p><b>111 899 115A10</b> <b>98-8995-B</b> Rubber Pad, Body Mounting (10mm), Lower, Type 1 53-77, Each</p> 	<p><b>113 903 531</b> <b>00-8902-7 •</b> Generator Brush Cover, Fits BOSCH GR15/17 generators. Each</p> 	<p><b>111 905 865K</b> <span style="color:red">NEW!</span> <b>98-9052-B</b> Switch, Ignition, Type 1 72-74, Each</p> 
<p><b>111 899 123A</b> <b>98-8996-B •</b> Rubber Pad, Body Mounting, Upper, Type 1 53-77, Each</p> 	<p><b>113 905 250</b> <b>00-8909-B •</b> Clamp, Distributor Hold Down, Type 1 61-79, Ghia 61-74, Type 2 61-71, Type 3 64-73, Each</p> 	<p><b>111 905 865L</b> <b>98-9053-B</b> Switch, Ignition (6 Contact Terminals), Type 1 74-79, Ghia 73-74, Type 2 74-79, Vanagon 80-92, Each</p> 
<p><b>040 903 109</b> <b>98-9012-B •</b> Alternator Pulley w/ Air Fins, 12 Volt, for AL82N, Each</p> 	<p><b>111 905 261</b> <b>98-9021-B</b> Seal, Distributor Shaft, Type 1 50-79, Ghia 54-74, Type 2 50-79, Type 3 64-73, Each</p> 	<p><b>113 919 029</b> <b>98-2019-B •</b> Fuel Gauge, Type 1 62-67, Each</p> 
<p><b>043 903 109</b> <b>00-9166-B •</b> Generator/Alternator Pulley, 12-Volt, Zinc, Type 1 67-79, Ghia 67-74, Type 2 67-71, Each</p> 	<p><b>113 905 451A</b> <b>98-9022-B</b> Cable Holder, (3 Wire), Type 1 50-79, Ghia 54-74, Type 2 50-79, Vanagon 79-83, Type 3 64-73, Each</p> 	<p><b>113 919 049C</b> <b>98-2020-B •</b> Sender, Fuel Gauge, Type 1 62-67, Ghia 62-66, Each</p> 
<p><b>111 903 131A</b> <b>00-9197-B •</b> Shim Kit, Generator/Alternator Pulley (Bag of 100), Type 1 50-79, Ghia 56-74, Type 2 50-71, Type 3 64-73</p> 	<p><b>111 905 803D</b> <b>98-2050-B •</b> Ignition Switch w/ Keys, Type 1 58-67, Ghia 61-66, Each</p> 	<p><b>113 919 049D</b> <b>98-2021-B •</b> Sender, Fuel Gauge, Type 1 68-77, Ghia 68-74, Each</p> 
<p><b>111 903 137B</b> <b>98-0090-B</b> Stock Size Pulley Belt, 10.0 x 900mm</p> 	<p><b>211 905 811C</b> <span style="color:red">NEW!</span> <b>98-2051-B •</b> Ignition Switch w/ Keys, Type 2 55-67</p> 	<p><b>211 919 051A</b> <span style="color:red">NEW!</span> <b>98-9193-B</b> Fuel Tank Sending Unit, Stock Replacement, Type 2 73-79, Each</p> 

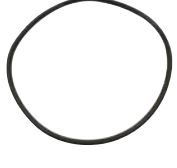

# REPLACEMENT PARTS

<p><b>271 919 051B</b> <b>98-9194-B</b> Sender, Fuel Gauge, Type 2 55-66, Each</p> 	<p><b>211 941 073</b> <b>98-9624-B</b> • Back-Up Light Assy., 57-71 Type 2, Each</p> 	<p><b>111 941 119</b> <b>98-9411-B</b> Gasket, Headlight Lens, Type 1 50-66, Type 2 50-67, Grey, Each</p> 
<p><b>113 919 051F</b> <b>98-2022-B</b> • Sender, Fuel Gauge, Super Beetle, Type 1 71-79, Each</p> 	<p><b>111 941 111</b> <b>98-2059-B</b> • Headlight Door (Screws at 5 and 7 O'clock), Type 1 50-66, Type 2 50-67, Each</p> 	<p><b>111 941 125C</b> <b>98-9412-B</b> Retainer Spring, Headlight Glass, Type 1 50-67, Type 2 50-67, Each</p> 
<p><b>021 919 081B</b> <b>98-9190-B</b> • Oil Pressure Switch, Type 1 All, Ghia All, Type 2 All, Vanagon All, Type 3 All, Each</p> 	<p><b>111 941 111B</b> <b>98-2060-B</b> • Headlight Door (Screws at 2 and 7 O'clock), Type 1 50-66, Type 2 50-67, Each</p> 	<p><b>311 941 177</b> <b>00-9479-B</b> • Headlight Door, Chrome, Type 1 67-79, Type 2 68-79, Type 3 64-73, Each</p> 
<p><b>113 919 133</b> <b>98-2037-B</b> • Gasket, Fuel Sender, Type 1 62-77, Ghia 62-74, Type 2 62-79, Type 3 64-73, Each</p> 	<p><b>111 941 115H</b> <b>98-9501-B</b> • Early Headlight Lens, Type 1 50-66, Type 2 50-67, Each</p> 	<p><b>111 941 191</b> <b>98-9414-B</b> Gasket, Headlight Assembly, Type 1 50-66, Type 2 50-67, Each</p> 
<p><b>111 941 037C</b> <b>98-1063-B</b> Headlight Assembly, Brazil, Type 1 50-66, Type 2 50-67, Each</p> 	<p><b>111 941 115HCB</b> <b>98-9502-B</b> • Early Headlight Lens, Cibie Style, Type 1 50-66, Each</p> 	<p><b>311 941 195A</b> <b>98-9415-B</b> Screw, Headlight Rim (Chrome), Type 1 67-79, Type 2 68-79, Type 3 64-73, Each</p> 
<p><b>141 941 041</b> <b>98-1064-B</b> • Headlight Retaining Assembly, Type 1 67-79, Ghia 64-74, Type 2 68-79, Type 3 64-73, Each</p> 	<p><b>111 941 115HT2</b> <b>98-9504-B</b> • Early Headlight Lens, Type 2 50-67, Each</p> 	<p><b>111 941 371</b> <b>98-9625-B</b> • Back-Up Light Lens Only, Type 1 64-67, Ghia 69-71, Type 3 67-69, 57-71 Type 2, Each</p> 
<p><b>181 941 071B</b> <b>98-9622-B</b> • Back-Up Light Assy., w/ Left Bracket &amp; Boot, Type 1 64-67, Ghia 69-71, Type 3 67-69, Each</p> 	<p><b>111 941 115HVN</b> <b>98-9503-B</b> • Early Headlight Lens, Vintage Style, Type 1 50-66, Each</p> 	<p><b>211 941 521</b> <b>98-9416-B</b> Switch, Back-up Light, Type 1 66-79, Ghia 66-74, Type 2 67-79, Type 3 66-73, Each</p> 
<p><b>181 941 072B</b> <b>98-9623-B</b> • Back-Up Light Assy., w/ Right Bracket &amp; Boot, Type 1 64-67, Ghia 69-71, Type 3 67-69, Each</p> 	<p><b>111 941 115POR</b> <b>98-9505-B</b> • Early Headlight Lens, Porsche Style, Type 1 50-66, Each</p> 	<p><b>311 941 531A</b> <b>98-9421-B</b> Switch, Headlight, Push/ Pull, Type 1 58-67, Ghia 58-67, Type 2 68-70, Type 3 64-67, Each</p> 

(•) Also available in skinpack **499**

# REPLACEMENT PARTS



<p><b>211 941 531E</b> <b>98-9980-B</b> Headlight Switch, Type 2 71-79</p> 	<p><b>111 945 095RE</b> <b>98-1091-B •</b> Tail Light Assy., Left w/Euro Lens, Type 1 68-70, Each (Painted Metal)</p> 	<p><b>113 945 110</b> <b>98-9507-B •</b> Tail Light Reflector, Right, Type 1 70-72, Each</p> 
<p><b>111 941 561B</b> <b>98-9436-B</b> Metal Housing Switch, Headlight Dimmer, Type 1 50-65, Ghia 54-65, Type 2 50-65, Each</p> 	<p><b>111 945 096NE</b> <b>98-2024-B •</b> Tail Light Assy., Right w/Euro Lens, Type 1 62-67, Each (Painted Metal)</p> 	<p><b>211 945 119A</b> <b>98-9508-B •</b> Side Marker Lens, Yellow/Silver, Type 2 70-74, Each</p> 
<p><b>111 941 583</b> <b>98-9437-B</b> Relay, headlight (12-Volt), Type 1 67-79, Ghia 67-74, Type 2 67-79, Type 3 67-73, Each</p> 	<p><b>111 945 096RE</b> <b>98-1092-B •</b> Tail Light Assy., Right w/Euro Lens, Type 1 68-70, Each (Painted Metal)</p> 	<p><b>211 945 119B</b> <b>98-9509-B •</b> Side Marker Lens, Yellow/Black, Type 2 75-79, Each</p> 
<p><b>111 943 191B</b> <b>00-6714-B •</b> Seal, License Light Housing, Type 1 52-57, Each</p> 	<p><b>133 945 097A</b> <b>98-9452-B •</b> Tail Light Assy., Left/Right, Universal, Type 1 73-79, Each (Black Plastic)</p> 	<p><b>211 945 161</b> <b>98-9512-B •</b> Front Side Reflector Base, Type 2 70-79, Each</p> 
<p><b>111 943 191C</b> <b>00-6713-B •</b> Seal, License Light Housing, Type 1 58-63, Each</p> 	<p><b>133 945 097AK</b> <b>98-9455-B •</b> Tail Light Assy., Left, Type 1 73-79, Each (Gray Plastic)</p> 	<p><b>111 945 191E</b> <b>00-6704-B •</b> Seal, Tail Light Assy., L &amp; R, Pair, Type 1 62-67</p> 
<p><b>111 943 191E</b> <b>00-6708-B •</b> Seal, License Light Housing, Type 1 67-79, Each</p> 	<p><b>133 945 097/8A</b> <b>98-9988-B</b> T/L Assembly, Left &amp; Right, 73-79, Each</p>  	<p><b>111 945 191G/2A</b> <b>00-6705-B •</b> Seal, Tail Light Assy., L &amp; R, Pair, Type 1 68-70</p> 
<p><b>113 943 191</b> <b>00-6707-B</b> Seal, License Light Housing, Type 1 64-66, Each</p> 	<p><b>133 945 098AK</b> <b>98-9456-B •</b> Tail Light Assy., Right, Type 1 73-79, Each (Gray Plastic)</p> 	<p><b>113 945 191/192</b> <b>00-6706-B •</b> Seal, Tail Light Assy., L &amp; R, Pair, Type 1 71-72</p> 
<p><b>111 945 095NE</b> <b>98-2023-B •</b> Tail Light Assy., Left w/Euro Lens, Type 1 62-67, Each (Painted Metal)</p> 	<p><b>113 945 109</b> <b>98-9506-B •</b> Tail Light Reflector, Left, Type 1 70-72, Each</p> 	<p><b>133 945 223A</b> <b>98-1065-B •</b> Lens, Tail Light, Left, Type 1 73-79, Each</p> 

**500** (•) Also available in skinpack

**EMPI • BUGPACK • MR. BUG • TREUHAFT • AUTO HAUS**

























# REPLACEMENT PARTS

<p><b>311 945 223B</b> <b>98-9626-B •</b> Tail Light lens, Type 3 64-69, Each</p> 	<p><b>211 945 241G</b> <b>98-9513-B •</b> Lens, Tail Light, Red, Type 2 62-71, Each</p> 	<p><b>211 945 245A</b> <b>98-9631-B •</b> Tail Light Seals, Type 2 62-71, Each</p> 
<p><b>311 945 223P</b> <b>98-9627-B •</b> Tail Light lens, Type 3 70-73, Ghia 72-74, Each</p> 	<p><b>111 945 241J</b> <b>98-1077-B •</b> Lens, Tail Light, Red/Red, Type 1 68-70, Each</p> 	<p><b>211 945 351A</b> <b>98-9516-B •</b> Bulb Holder, Type 2, Rear Side Marker, Type 2 70-79, Each</p> 
<p><b>133 945 224A</b> <b>98-1066-B •</b> Lens, Tail Light, Right, Type 1 73-79, Each</p> 	<p><b>111 945 241JE</b> <b>98-1076-B •</b> Lens, Tail Light, Red/Amber, Type 1 68-70, Each</p> 	<p><b>211 945 363A</b> <b>98-9510-B •</b> Side Marker Lens, Red/Silver, Type 2 70-74, Each</p> 
<p><b>211 945 237K</b> <b>98-9514-B •</b> Tail Light Assembly, Type 2 62-71, Each</p> 	<p><b>211 945 241R</b> <b>98-9454-B •</b> Lens, Tail Light, Red/Amber, Type 2 72-79, Each</p> 	<p><b>211 945 363B</b> <b>98-9511-B •</b> Side Marker Lens, Red/Black, Type 2 75-79, Each</p> 
<p><b>113 945 241A</b> <b>98-2025-B •</b> Lens, Tail Light, Red/Red, Left, Type 1 71-72, Each</p> 	<p><b>211 900 145GH</b> <b>98-9989-B</b> T/L Assy., Left &amp; Right, Amber/Red/White, 72-79, Each</p>  	<p><b>113 945 515G</b> <b>98-2057-B •</b> Switch, Brake Light, 3 Prong, Type 1 68-79, Ghia 68-74, Type 2 68-79, Vanagon 80-91, Type 3 68-73, Each</p> 
<p><b>113 945 241B</b> <b>98-9629-B •</b> Tail Light lens - Euro, Type 1 71-72, Left, Each</p> 	<p><b>211 945 241RA</b> <b>98-9453-B •</b> Tail Light Assy., Red, Type 2 72-79, Each</p> 	<p><b>113 945 515H</b> <b>98-2058-B •</b> Switch, Brake Light, 2 Prong, Type1 50-67, Ghia 56-67, Type 2 50-67, Type 3 64-67, Each</p> 
<p><b>111 945 241D</b> <b>98-1075-B •</b> Lens, Tail Light, Red/Red, Type 1 62-67, Each</p> 	<p><b>113 945 242A</b> <b>98-2026-B •</b> Lens, Tail Light, Red/Red, Right, Type 1 71-72, Each</p> 	<p><b>111 947 111E</b> <b>98-1089-B •</b> Push-on terminals, 1970-77 Type 1 (Exc. Convertible). Will fit 52-69 but will not have the OE look.</p> 
<p><b>111 945 241DE</b> <b>98-1074-B •</b> Lens, Tail Light, Red/Amber, Type 1 62-67, Each</p> 	<p><b>113 945 242B</b> <b>98-9630-B •</b> Light lens - Euro, Type 1 71-72, Right, Each</p> 	<p><b>113 947 565A</b> <b>98-2035-B •</b> Seal, Door Contact Switch, Type 1 61-79, Ghia 61-74, Type 2 68-79, Type 3 64-73, Each</p> 

(•) Also available in skinpack **501**

# REPLACEMENT PARTS

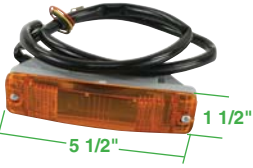

<p><b>111 951 111H</b> <b>98-2030-B •</b> Horn, 6-Volt, Type1 50-66, Ghia 56-66, Type 2 55-66, Type 3 64-66, Each</p> 	<p><b>211 953 141/142</b> <b>98-9635-B •</b> Turn Signal Lens - Amber, Type 2 73-79, Left/Right, Each</p> 	<p><b>113 953 161BCL</b> <b>98-9518-B •</b> Turn Signal Lens, Left, Clear, Type 1 70-79, Each</p> 
<p><b>111 951 113B</b> <b>98-2031-B •</b> Horn, 12-Volt, Type 1 67-79, Ghia 67-74, Type 2 62-79, Type 3 67-73, Vanagon 80-91, Each</p> 	<p><b>211 953 141J</b> <b>98-9525-B •</b> Turn Signal Lens, L or R, Type 2 68-71, Each</p> 	<p><b>211 953 161B</b> <b>98-9640-B •</b> Turn Signal Lens - Amber, Type 2 63-67, Left, Each</p> 
<p><b>113 953 041C</b> <b>98-9530-B •</b> Turn Signal Assy., L or R, Type 1 58-63, Each (Chrome Plated Steel)</p> 	<p><b>311 953 157J</b> <b>98-9637-B •</b> Turn Signal Lens - Amber, Type 3 70-73, Left/Right, Each</p> 	<p><b>315 953 161D</b> <b>98-9526-B •</b> Turn Signal Lens, Bullet, KG/T3, Amber, Ghia 64-69, Type 3 64-69, Each</p> 
<p><b>113 953 041CA</b> <b>98-9529-B •</b> Turn Signal Assy., Amber, Type 1 58-63, Each (Chrome Plated Steel)</p> 	<p><b>111 953 161</b> <b>98-9638-B •</b> Turn Signal Lens - Clear, Type 1 55-57, Type 2 56-62, Left/Right, Each</p> 	<p><b>315 953 161DCL</b> <b>98-9527-B •</b> Turn Signal Lens, Bullet, KG/T3, Clear, Ghia 64-69, Type 3 64-69, Each</p> 
<p><b>113 953 041J</b> <b>98-9531-B •</b> Turn Signal Assy., L or R, Type 1 64-66, Each (Chrome Plated Plastic)</p> 	<p><b>111 953 161A</b> <b>98-9639-B •</b> Turn Signal Lens - Amber, Type 1 68-69, Left/Right, Each</p> 	<p><b>111 953 161J</b> <b>98-9524-B •</b> Turn Signal Lens, Amber, Type 1 64-66, Each</p> 
<p><b>113 953 041N</b> <b>98-9533-B •</b> Turn Signal Assy., Left, Type 1 70-79, Each (Chrome Plated Plastic)</p> 	<p><b>113 953 161A</b> <b>98-9522-B •</b> Turn Signal Lens, Amber, Type 1 58-63, Each</p> 	<p><b>111 953 161JCL</b> <b>98-9523-B •</b> Turn Signal Lens, Clear, Type 1 64-66, Each</p> 
<p><b>113 953 042N</b> <b>98-9534-B •</b> Turn Signal Assy., Right, Type 1 70-79, Each (Chrome Plated Plastic)</p> 	<p><b>113 953 161ACL</b> <b>98-9521-B •</b> Turn Signal Lens, Clear, Type 1 58-63, Each</p> 	<p><b>113 953 162B</b> <b>98-9519-B •</b> Turn Signal Lens, Right, Amber, Type 1 70-79, Each</p> 
<p><b>113 953 049AK</b> <b>98-1071-B •</b> Turn Signal Assy., L or R for 113 707 103DM, Type 1 68-73, Each</p>  <p>5 1/2" x 1 1/2"</p>	<p><b>113 953 161B</b> <b>98-9517-B •</b> Turn Signal Lens, Left, Amber, Type 1 70-79, Each</p> 	<p><b>113 953 162BCL</b> <b>98-9520-B •</b> Turn Signal Lens, Right, Clear, Type 1 70-79, Each</p> 



# REPLACEMENT PARTS

<p><b>211 953 162B</b> <b>98-9641-B •</b> Turn Signal Lens - Amber, Type 2 63-67, Right, Each</p> 	<p><b>141 953 517F</b> <b>98-9576-B •</b> Switch, Turn Signal, Type 1 62-67, Ghia 62-67, Black, Each <b>(Do not connect dimmer switch wire on early cars)</b></p>  <p>OEM Type 1 62-65 is ivory in color. EMPI's is black.</p>	<p><b>111 955 407F</b> <b>98-9552-B •</b> Wiper Arm, Silver, Left, Type 1 70-72, Each</p> 
<p><b>111 953 193</b> <b>00-6701-B •</b> Seal, Turn Signal, Pair, Type 1 58-63</p> 	<p><b>113 955 113E</b> <b>17-2807-0</b> <b>039 024 6050 (Bosch Reference)</b> 12 Volt Wiper Motor, Type 1, 69-71, Boxed 2 Speed Motor Negative Ground</p> 	<p><b>111 955 407H</b> <b>98-9549-B •</b> Wiper Arm, Black, Left, Type 1 73-77 (Exc. S/B) Super Beetle Sedan 71-72</p> 
<p><b>113 953 193</b> <b>00-6703-B •</b> Seal, Turn Signal, Pair, Type 1 70-79</p> 	<p><b>311 955 261A</b> <b>98-9580-B</b> Ferrule, Windshield Wiper Shaft, S/B, 71-72, Type 1 70-77, Ghia 68-74, Type 2 69-79, Type 3 64-73, Each</p> 	<p><b>111 955 408</b> <b>98-9558-B •</b> Wiper Arm, Silver, Right, Type 1 68-69, Each</p> 
<p><b>111 953 193E</b> <b>00-6702-B •</b> Seal, Turn Signal, Pair, Type 1 64-69</p> 	<p><b>211 955 275A</b> <b>98-9581-B</b> Protective Cover, Windshield Wiper Shaft, Type 1 70-79, Ghia 70-74, Type 2 69-79, Type 3 70-73, Each</p> 	<p><b>111 955 408B</b> <b>98-9555-B •</b> Wiper Arm, Silver, Right, Type 1 70-72, Each</p> 
<p><b>211 953 235A</b> <b>98-9575-B</b> Switch, Emergency Flasher, S/B 71-72, Type 1 68-73, Ghia 68-73, Type 2 68-72, Type 3 68-72, Each</p> 	<p><b>221 955 407A</b> <b>98-9642-B</b> Wiper Arm, Silver, Type 2 to 67, Each</p> 	<p><b>111 955 408H</b> <b>98-9550-B •</b> Wiper Arm, Black, Right, Type 1 73-77 (Exc. S/B) Super Beetle Sedan 71-72</p> 
<p><b>311 953 513B</b> <b>98-9539-B •</b> Switch, Turn Signal, Type 1 68-70, Ghia 68-70, Type 3 68-69, Each</p> 	<p><b>113 955 407B</b> <b>98-9553-B •</b> Wiper Arm, Silver, Left or Right, Type 1 58-64, Each</p> 	<p><b>133 955 409</b> <b>98-9556-B •</b> Wiper Arm, Black, Left, Super Beetle, Type 1 73-79, Each</p> 
<p><b>111 953 513C</b> <b>98-9537-B •</b> Switch, Turn Signal, Type 1 71, Ghia 71, Each</p> 	<p><b>111 955 407D</b> <b>98-9551-B •</b> Wiper Arm, Silver, Left, Type 1 68-69, Each</p> 	<p><b>133 955 410</b> <b>98-9557-B •</b> Wiper Arm, Black, Right, Super Beetle, Type 1 73-79, Each</p> 
<p><b>111 953 513F</b> <b>98-9538-B •</b> Switch, Turn Signal, Type 1 72-79, Ghia 72-74, Type 3 72-73, Each</p> 	<p><b>113 955 407D</b> <b>98-9554-B •</b> Wiper Arm, Silver, Left or Right, Type 1 65-67, Each</p> 	<p><b>111 955 425B</b> <b>98-9644-B •</b> Wiper Blade, 10.5" / 268mm, Silver, Type 1 65-67, Each</p> 

# REPLACEMENT PARTS



















<p><b>113 955 425B</b> <b>98-9559-B</b> Wiper Blade, 10" / 255mm, Black, Type 1 58-64, Type 2 50-67, Each</p> 	<p><b>211 957 801E</b> <b>98-9804-B</b> Speedometer Cable, Type 2 55-67, Each</p> 	<p><b>N011 152 1</b> <b>98-0112-B</b> Nut for Valve Adjustment Screw, Type 1 50-79, Each</p> 
<p><b>221 955 425C</b> <b>98-9643-B</b> Wiper Blade, 10.75" / 274mm, Silver, Type 2 to 67, Each</p> 	<p><b>111 957 801J</b> <b>98-9801-B</b> Speedometer Cable, Type 1 58-65, Each</p> 	<p><b>N012 548 1</b> <b>98-0118-B</b> Cotter Pin, Rear Axle Nut (5 x 55mm), Type 1 50-79, Ghia 56-74, Type 2 50-79, Type 3 64-73, Each</p> 
<p><b>211 955 425CBL</b> <b>98-9645-B</b> Wiper Blade, 10.75" / 274mm, Black, Type 2 to 67, Each</p> 	<p><b>111 957 801K</b> <b>98-9802-B</b> Speedometer Cable, Type 1 66-74, Each</p> 	<p><b>N012 705 1</b> <b>98-0111-B •</b> Bulk Gen./Alt. Woodruff Key, Type 1 50-79, Ghia 56-74, Type 2 50-71, Type 3 64-73, Each</p> 
<p><b>111 955 425F</b> <b>98-9548-B</b> Wiper Blade, 11.3" / 288mm, Black, Type 1 68-77 (Exc. S/B), Super Beetle 71-72</p> 	<p><b>111 957 861</b> <b>98-9809-B</b> Dust Boot, Speedometer Cable, Type 1 61-77, Ghia 56-74, Each</p> 	<p><b>N013 776 1</b> <b>98-0119-B</b> Gasket, Carburetor Base, 28/30 PICT Carburetor, Type 1 50-70, Ghia 56-70, Type 2 50-70, Each</p> 
<p><b>113 955 425S</b> <b>98-9566-B</b> Wiper Blade, 10" / 255mm, Silver, Type 1 58-64, Type 2 50-67, Each</p> 	<p><b>111 998 031</b> <b>98-9986-B</b> Ignition Wire Set, Type 1 50-79, Ghia 56-74, Type 2 50-71, Each</p>  <p><b>BOSCH</b></p>	<p><b>N 014 779 1</b> <b>99-4372-0</b> Bolt – Rotor to Hub, 8.8 Grade Socket Head M8X20 Bolt, Type 2, 73-79, Each</p> 
<p><b>133 955 435</b> <b>98-9582-B</b> Cap, Windshield Wiper Shaft, Type 1 73-79, Ghia 70-74, Type 2 73-79, Type 3 70-73, Each</p> 	<p><b>111 998 031A</b> <b>00-9314-B •</b> Ignition Wire Set, Black, Type 1 52-79, Ghia 56-74, Type 2 thru 71, Each</p>  <p>(USA Made)</p>	<p><b>N020 029 1</b> <b>98-0120-B •</b> Rubber Stop, Fuel Filler Door/ Glove Box, Type 1 52-77, Ghia 56-74, Type 2 68-79, Type 3 64-73, Each</p> 
<p><b>111 955 993A</b> <b>98-9586-B</b> Nozzle, Windshield Washer, Type 1 60-79, Ghia 61-74, Type 3 64-73, Each</p> 	<p><b>N012 810 1</b> <b>98-0117-B •</b> Pin for Window Crank and Door Handle, Each, Type 1 50-67, Ghia 50-67, Each</p> 	<p><b>N020 112 1</b> <b>70-2860-7 •</b> Lug Nut (M14 x 1.5), Steel Wheel, Gold, Each</p> 
<p><b>113 957 801A</b> <b>98-9803-B</b> Speedometer Cable, Super Beetle, Type 1 71-74, Each</p> 	<p><b>N10 710 8</b> <b>00-9524-B •</b> Sheet Metal Screws (Bag of 100), Type 1 50-79, Ghia 56-74, Type 2 50-79, Type 3 64-73</p> 	<p><b>N 137 761</b> <b>00-3254-7 •</b> 30 PICT 1 Base Gasket, Each</p> 





# REPLACEMENT PARTS

<p><b>N14 389 1</b> <b>00-4846-B •</b> Door Panel Clip (Bag of 100), Type 1 50-79, Ghia 56-74, Type 2 68-79, Type 3 64-73</p> 	<p><b>GR15N</b> <b>BOSCH</b> <b>98-9031-B</b> Generator, 12-Volt, Type 1 67-74, Ghia 67-74, Type 2 67-68, Each <b>New, No Core</b></p> 	<p><b>WR8DP</b> <b>BOSCH</b> <b>98-9823-B</b> Spark Plug, Each, 4 per Box, Sold Each 14mm, 3/4" Reach <b>NEW!</b></p> 
<p><b>N171211</b> <b>00-9929-B</b> 8 Amp Fuses, White Box of 100</p> 	<p><b>SR11X</b> <b>BOSCH</b> <b>98-9112-B</b> Starter, 6-Volt, Type 1 50-66, Ghia 56-66, Type 2 50-66, Each <b>Remanufactured, No Core</b></p> 	<p><b>DP7EA9</b> <b>98-9937-B</b> Spark Plug, <b>NGK</b>, Sold Each 12mm, 3/4" Reach</p>  
<p><b>N171214</b> <b>00-9930-B</b> 16 Amp Fuses, Red Box of 100</p> 	<p><b>SR15N</b> <b>BOSCH</b> <b>98-9110-B</b> Starter, 12-Volt, Type 1 67-79, Ghia 67-74, Type 2 67-71, Each <b>New, No Core</b></p> 	<p><b>DP8EA9</b> <b>98-9938-B</b> Spark Plug, <b>NGK</b>, Sold Each 12mm, 3/4" Reach</p>  
<p><b>N171215</b> <b>00-9931-B</b> 25 Amp Fuses, Blue Box of 100</p> 	<p><b>SR15NCH</b> <b>98-9114-B</b> <b>EMPI</b> Starter, 12-Volt New, Type 1 67-79 Exc. AutoStick</p> 	<p><b>DP9EA9</b> <b>98-9939-B</b> Spark Plug, <b>NGK</b>, Sold Each 12mm, 3/4" Reach Tip Installed on Plug</p>  
<p><b>N20 353 1</b> <b>98-0122-B</b> OE Style Braided Fabric Fuel Hose, 3.5mm I.D., 10 Meter Roll</p> 	<p><b>WR7AC</b> <b>BOSCH</b> <b>98-9931-B</b> Spark Plug, Each, 4 per Box, Sold Each 14mm, 1/2" Reach Tip Installed on Plug</p> 	<p><b>B6HS</b> <b>98-9944-B</b> Spark Plug, <b>NGK</b>, Sold Each 14mm x 13/16" Hex</p>  
<p><b>N20 355 1</b> <b>98-0123-B</b> OE Style Braided Fabric Fuel Hose, 5mm I.D., 10 Meter Roll</p> 	<p><b>WR8AC</b> <b>BOSCH</b> <b>98-9932-B</b> Spark Plug, Each, 4 per Box, Sold Each 14mm, 1/2" Reach Tip Installed on Plug</p> 	<p><b>B8ES</b> <b>98-9945-B</b> <b>NEW!</b> Spark Plug, <b>NGK</b>, Sold Each 14mm, 3/4" Reach Tip Installed on Plug</p>  
<p><b>AL82N</b> <b>00-9444-1</b> (Bosch) Alternator, Each 55 Amp <b>New, No Core</b> <b>BOSCH</b></p> 	<p><b>W7CC</b> <b>BOSCH</b> <b>98-9933-B</b> Spark Plug, Each, 10 per Box, Sold Each 14mm, 3/4" Reach Tip Installed on Plug</p> 	<p><b>30 019</b> <b>BOSCH</b> <b>98-9068-B</b> Voltage Regulator, 12-Volt, Type 1 67-74, Ghia 67-74, Type 2 67-68, Each</p> 
<p><b>00-9445-7</b> <b>EMPI</b> Alternator, 55 Amp, Type 1 75-79, Each <b>New, No Core</b></p> 	<p><b>WR8CC</b> <b>BOSCH</b> <b>98-9934-B</b> Spark Plug, Each, 4 per Box, Sold Each 14mm, 3/4" Reach Tip Installed on Plug</p> 	<p><b>0 231 178 009EC</b> <b>00-9431-B</b> EMPI Street Model Centrifugal Advance Distributor, Standard Curve (Boxed)</p> 

(•) Also available in skinpack **505**

# REPLACEMENT PARTS



<p><b>00-9406-B</b> Coil, 12-Volt Non-Resistor w/bracket, Each(Blue in Color)</p> 	<p><b>02 054</b> <b>98-9946-B</b> Condenser, Each</p> 	<p><b>04 004</b> <b>98-9821-B •</b> Distributor Rotor, Each</p> 
<p><b>00 012</b> <b>00-9409-B</b> Blue Coil, 12-Volt, Works with Electronic Ignition, Each (Blue in Color)</p> 	<p><b>02 069</b> <b>98-9947-B</b> Condenser, Each</p> 	<p><b>04 006</b> <b>98-9955-B</b> Distributor Rotor, Each</p> 
<p><b>00 016</b> <b>00-9408-B</b> Blue Coil, 6-Volt, Non Resistor, Each (Silver in Color)</p> 	<p><b>02 074</b> <b>98-9948-B</b> Condenser, Each</p> 	<p><b>04 008</b> <b>98-9822-B •</b> Distributor Rotor, Each</p> 
<p><b>01 009</b> <b>98-9941-B</b> Ignition Points, Each</p> 	<p><b>02 086</b> <b>00-9434-B •</b> Condenser for 009, Each</p> 	<p><b>04 010</b> <b>98-9956-B</b> Distributor Rotor, Each</p> 
<p><b>01 011</b> <b>00-9433-B •</b> Points for 009, Each</p> 	<p><b>03 001</b> <b>98-9951-B</b> Distributor Cap, Each</p> 	<p><b>04 016</b> <b>98-9603-0 •</b> 5,400 RPM Rev Limiter, Each</p> 
<p><b>02 006</b> <b>98-9815-B</b> Condenser, Each</p> 	<p><b>03 010</b> <b>00-9435-B •</b> Distributor Cap, Each</p> 	<p><b>04 023</b> <b>98-9605-0 •</b> 6,500 RPM Rev Limiter, Each</p> 
<p><b>02 007</b> <b>98-9816-B</b> Condenser, Each</p> 	<p><b>03 019</b> <b>98-9819-B •</b> Distributor Cap, Each</p> 	<p><b>04 024</b> <b>98-9606-0 •</b> 6,800 RPM Rev Limiter, Each</p> 
<p><b>02 039</b> <b>98-9817-B</b> Condenser, Each</p> 	<p><b>03 172</b> <b>98-9820-B •</b> Distributor Cap, Each</p> 	<p><b>04 028</b> <b>98-9607-0 •</b> 7,100 RPM Rev Limiter, Each</p> 



# REPLACEMENT PARTS

<p><b>04 030</b> <b>98-9604-0 •</b> 5,800 RPM Rev Limiter, Each</p> <p><b>BOSCH</b></p> 	<p><b>09 003</b> <b>98-9923-B</b> Ignition Wire Set , Type 3 65-67, Each</p> <p><b>BOSCH</b></p> 	<p><b>40 716A</b> <b>98-9564-B</b> Wiper Blade, 16", Type 2 68-79, Each Includes Universal Adapters</p> <p><b>BOSCH</b></p> 
<p><b>04 110</b> <b>00-9436-B •</b> Rotor for 009, Each</p> <p><b>BOSCH</b></p> 	<p><b>09 004</b> <b>98-9924-B</b> Ignition Wire Set, Type 3 68-73, Each</p> <p><b>BOSCH</b></p> 	<p><b>40 718A</b> <b>98-9565-B</b> Wiper Blade, 18", Vanagon 80-91, Each Includes Universal Adapters</p> <p><b>BOSCH</b></p> 
<p><b>09 001</b> <b>98-9921-B</b> Ignition Wire Set, Type 1 50-79, Ghia 56-74, Type 2 50-71, Each</p> <p><b>BOSCH</b></p> 	<p><b>09 171</b> <b>98-9922-B</b> Ignition Wire Set, Type 2 72-79, Each</p> <p><b>BOSCH</b></p> 	

## HARD PARTS MADE EASY



 <p><b>DRUMS &amp; ROTORS</b></p>		<p><b>ENGINE BEARINGS</b></p> 	
	<p><b>IGNITION</b></p> 		<p><b>HEADS &amp; CASES</b></p> 
<p><b>CARBURETORS</b></p> 		<p><b>FUEL TANKS &amp; SENDERS</b></p> 	
			

(•) Also available in skinpack **507**

Learn more about driveline and axle parts we have.