

# Installation instructions

## For set # 19.3102

### 2013 Subaru WRX

### Front Control Arm Bushings



It is recommended that if you are unfamiliar with this type of work that you refer to a qualified service center specializing in this type of work. It is also recommended that if you choose to do this work yourself that a factory service manual be obtained for the proper procedures pertaining to removal, replacement and proper torque specifications for your vehicle. This instruction set is intended as a guideline for the safe installation of Energy Suspension's polyurethane bushings, once you have removed the factory components from your vehicle. Wheel alignment is almost always disturbed when suspension components are removed or replaced. It is recommended that you have the alignment checked on your vehicle at a qualified alignment shop. Energy Suspension recommends that you read over all the installation instructions and check all P/N's and quantities in the parts list before you start. Prior to installation, make sure that your vehicle is in excellent mechanical condition and that there are no suspension or steering related problems. This part has been designed to work only with a vehicle that is in good state of repair. No matter how carefully we design our parts, this is one area we have no control over and cannot be held responsible.

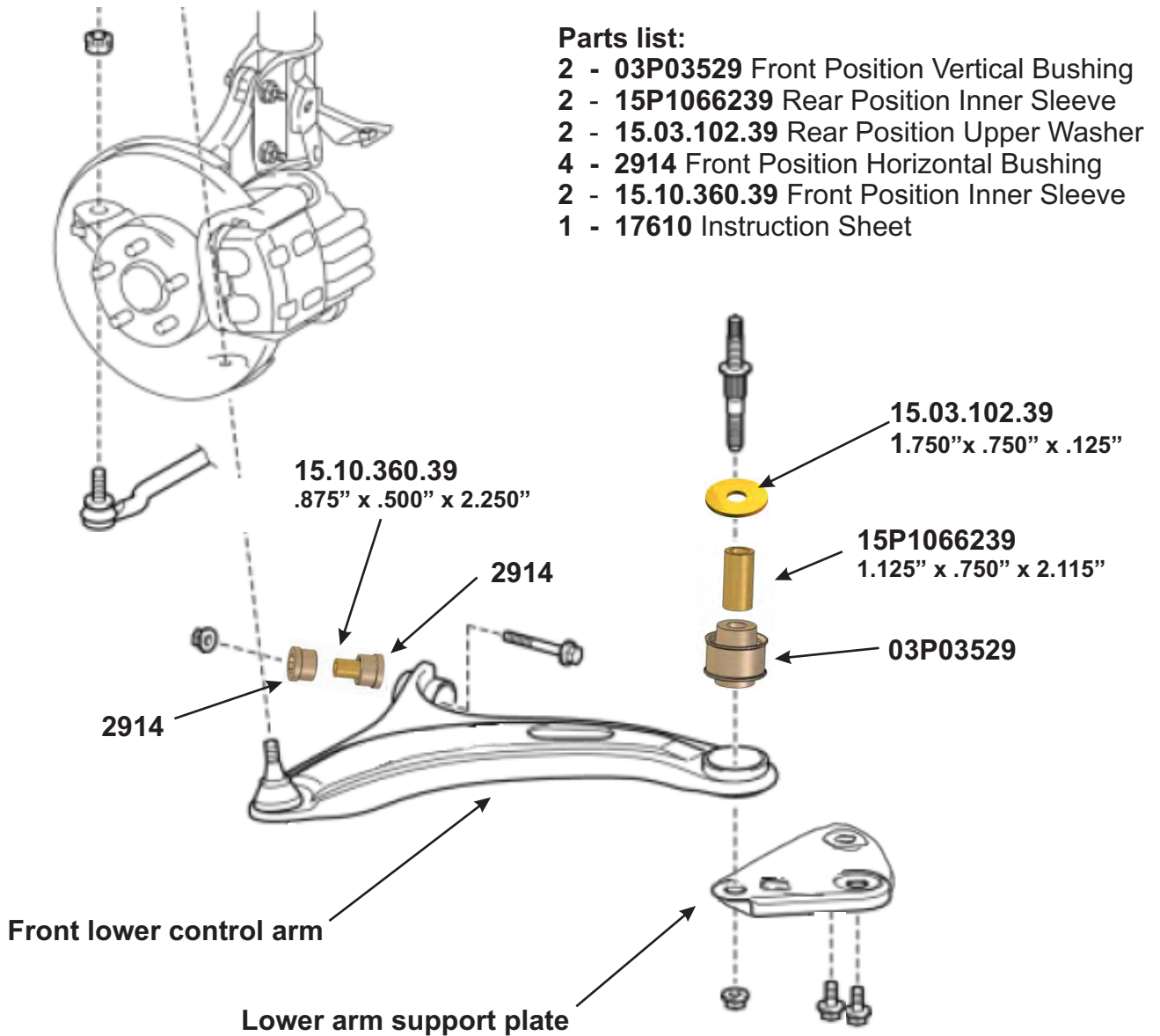

# Installation instructions

For set # 19.3102

2013 Subaru WRX

Front Control Arm Bushings

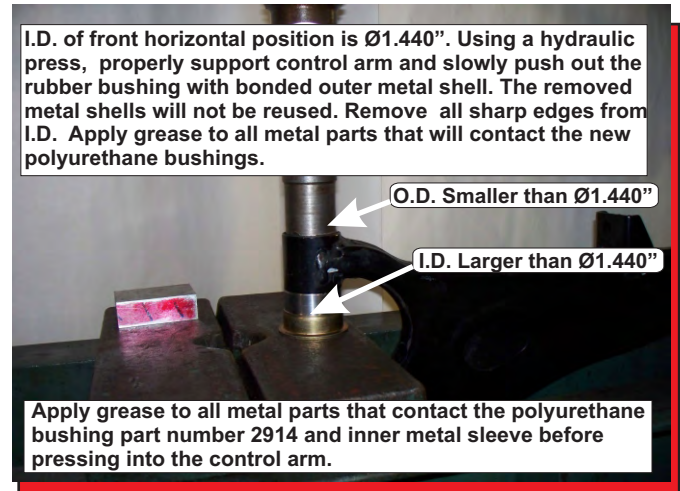
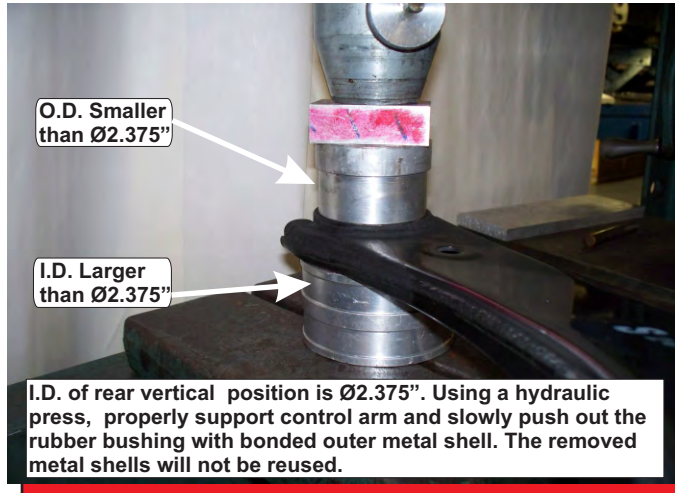

Install the bushing with p/n 03P03529 up. Only grease the leading edge to help get the bushing started. Do not grease the I.D. when installing the inner sleeve.