

Installation instructions

For Set # 3.1143

07-10 Chevy/GMC 2500/3500 2WD & 4WD
Torsion Bar Cross Member Frame Hanger Bushings



It is recommended that if you are unfamiliar with this type of work that you refer to a qualified service center specializing in this type of work. It is also recommended that if you choose to do this work yourself that a factory service manual be obtained for the proper procedures pertaining to removal, replacement and proper torque specifications for your vehicle. This instruction set is intended as a guideline for the safe installation of Energy Suspension's polyurethane bushings, once you have removed the factory components from your vehicle. Wheel alignment is almost always disturbed when suspension components are removed or replaced. It is recommended that you have the alignment checked on your vehicle at a qualified alignment shop. Energy Suspension recommends that you read over all the installation instructions and check all P/N's and quantities in the parts list before you start. Prior to installation, make sure that your vehicle is in top mechanical condition and that there are no suspension or steering related problems. This part has been designed to work only with a vehicle that is in good state of repair. No matter how carefully we design our parts, this is one area we have no control over and cannot be held responsible.

A torsion bar unloading/loading tool will be required (Fig.1). Before you start take some ride height measurements for reference to compare when the job is completed. Raise and support the vehicle. Before using the unloading/loading tool, measure from the top of the adjustment bolt to the adjuster nut. (Fig. 2). Using the unloading/loading tool increase the tension on the adjustment arm until the load is removed from the adjustment bolt and adjuster nut (Fig. 3). Remove the adjustment bolt and adjuster nut from the cross member. Remove the unloading/loading tool allowing the torsion bar to unload. Remove the adjustment arm by sliding the torsion bar forward (Fig. 4). Do the same for the other side. Remove the torsion bar cross member bolts and the cross member and set aside. Remove old factory rubber bushing bonded to outer metal shell (Fig. 5). Using large pliers, press the new polyurethane bushing into the eye of the mount (Fig. 6) and then the supplied metal sleeve (Fig. 7). Installation is reverse order of removal. Tighten the cross member bolts to 70 lb.ft. Install the adjuster bolt to the same measurement as noted before removal. Verify ride height after lowering the vehicle.

Parts list:

- 2 - 01P01347 (Hanger bushing)
- 2 - 15P1070539 (Sleeve 1.000 x .563 x 1.500)

Tools Required



TORSION BAR UNLOADING/LOADING TOOL

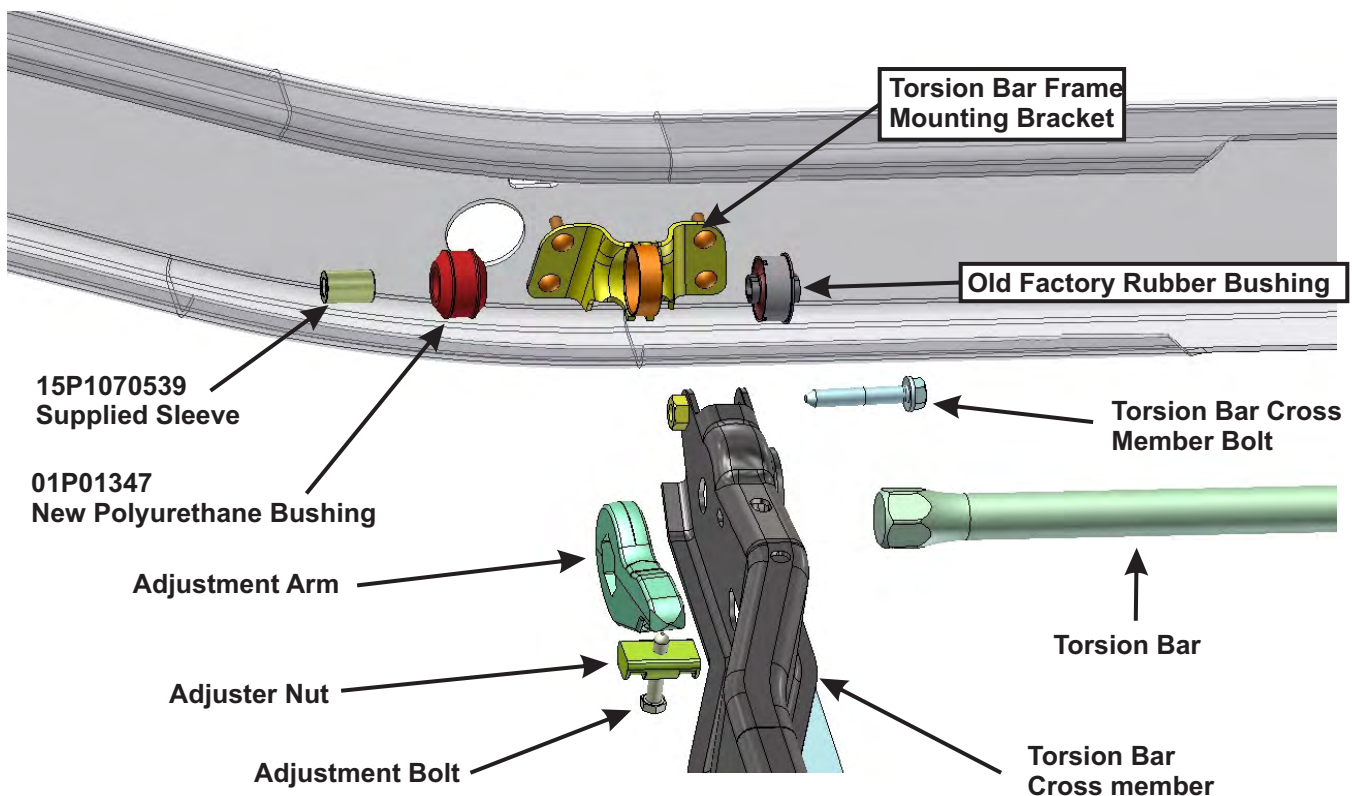

Installation instructions

For Set # 3.1143

07-10 Chevy/GMC 2500/3500 2WD & 4WD
Torsion Bar Cross Member Frame Hanger Bushings

ENERGY
SUSPENSION

