

# INSTRUCTION SHEET FOR SET #4.4123

Read this instruction sheet thoroughly before initiating any work!



It is recommended that if you are unfamiliar with this type of work that you refer to a qualified service center specializing in this type of work. It is also recommended that if you choose to do this work yourself that a factory service manual be obtained for the proper procedures pertaining to removal, replacement and proper torque specifications for your vehicle. This instruction set is intended as a guideline for the safe installation of Energy Suspension's polyurethane bushings, once you have removed the factory components from your vehicle. Wheel alignment is almost always disturbed when suspension components are removed or replaced. It is recommended that you have the alignment checked on your vehicle at a qualified alignment shop. Energy Suspension recommends that you read over all the installation instructions and check all P/N's and quantities in the parts list before you start. Prior to installation, make sure that your car is in excellent mechanical condition and that there are no suspension or steering related problems. This part has been designed to work only with a car that is in good state of repair. No matter how carefully we design our parts, this is one area we have no control over and cannot be held responsible.

## REMOVAL

**NOTE:** Be sure on disassembly to note the quantity and positions of any shims that may have been inserted for body alignment. These shims may or may not be reused. The new polyurethane body mounts will not settle like the old rubber body mounts. Use the shims where necessary to ensure proper body alignment. Install mounts one side at a time with bolts on other side loosened only. Use a wire brush to remove any rust from threads. Spray all nuts to be removed with your favorite rust buster. Remove bolts of mounts from inside of cab one side at a time, leave other side loose. When jacking up the body use a 2x4 or 4x4 for maximum support and weight distribution. Never place the jack directly on body panels. Watch that the fan, fan shroud, wires, brake lines, fuel lines, EVAP lines and fuel filler hoses are not stretched or hitting when lifted. The body mounts are pressed together by a flair fit from the factory. A simple puller assembly can be made with a tube that fits over the lower mount, some big flat washers and the O.E. bolt. (See pic). Using the O.E. bolt with the puller assembly and tightening it will separate the lower body mount from the upper body mount. Remove OEM bushings. Install the new bushings supplied and use the position diagram with the description in the parts list for placement of all hardware. **DO NOT** Tighten bolts until all the body mounts have been replaced on both sides. Tighten all bolts to factory specifications. recheck after 200 - 500 miles.

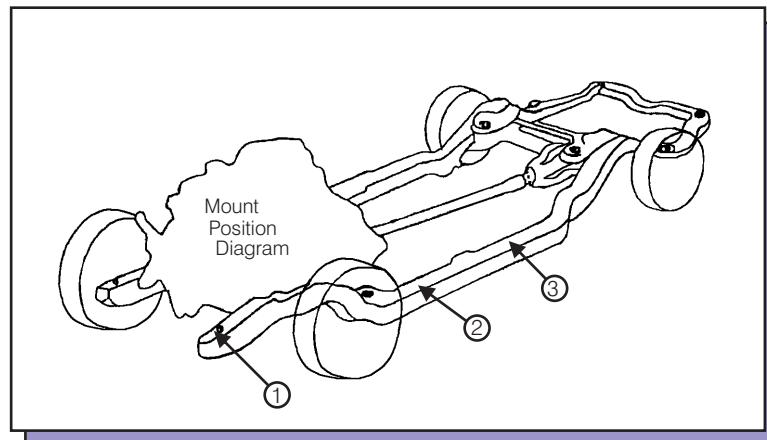

## Positions 1 & 2

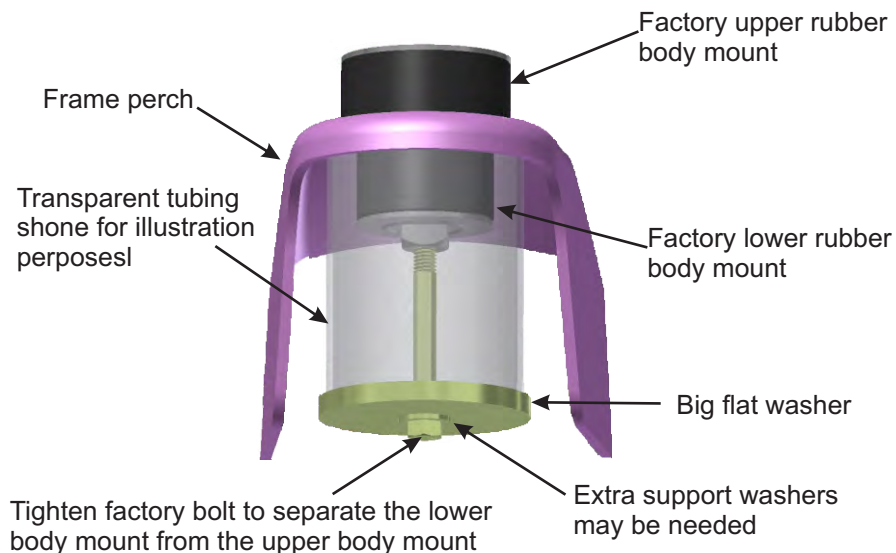

## Position 3

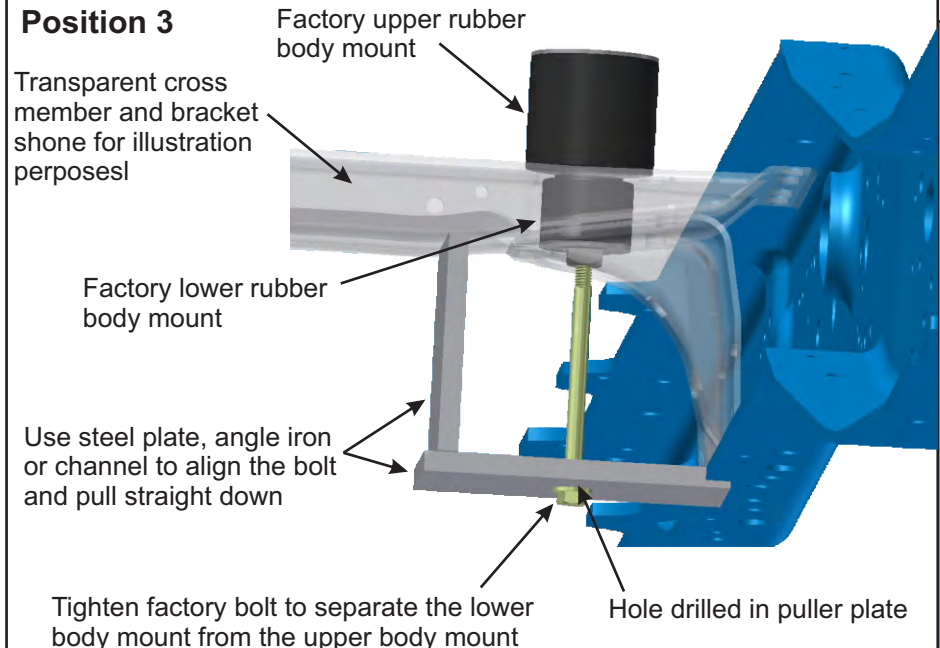

# INSTRUCTION SHEET FOR SET #4.4123

Read this instruction sheet thoroughly before initiating any work!



It is recommended that if you are unfamiliar with this type of work that you refer to a qualified service center specializing in this type of work. It is also recommended that if you choose to do this work yourself that a factory service manual be obtained for the proper procedures pertaining to removal, replacement and proper torque specifications for your vehicle. This instruction set is intended as a guideline for the safe installation of Energy Suspension's polyurethane bushings, once you have removed the factory components from your vehicle. Wheel alignment is almost always disturbed when suspension components are removed or replaced. It is recommended that you have the alignment checked on your vehicle at a qualified alignment shop. Energy Suspension recommends that you read over all the installation instructions and check all P/N's and quantities in the parts list before you start. Prior to installation, make sure that your car is in excellent mechanical condition and that there are no suspension or steering related problems. This part has been designed to work only with a car that is in good state of repair. No matter how carefully we design our parts, this is one area we have no control over and cannot be held responsible.

## Parts list:

- 2 - 04P04371 Core POS. 1 Upper
- 2 - 04P04372 Core POS. 1 Lower
- 2 - 04P04373 POS. 2 Upper
- 4 - 04P04374 POS. 2 & 3 Lower
- 2 - 04P04375 POS. 3 Lower
- 4 - 15.03.05.39 2" x 1/2" x 1/8"  
Washer
- 6 - 15.03.11.39 3" x 9/16" x 1/8"  
Washer
- 6 - 15.03.14.39 2-1/2" x 1/2" x 1/8"  
Washer
- 2 - 15.03.34.39 2-1/2" x 7/16" x 1/8"  
Washer Clipped
- 4 - 15.03.85.39 1-3/8" x .470" x 3/16"  
Washer
- 8 - 15P0314942 1" x .7/16" x 3/32"  
Washer
- 2 - 15.10.51.39 .875" x .625" x 2.125"  
Sleeve POS. 1
- 2 - 15.10.545.39 1.000" x .640" x  
2.300" Sleeve POS. 2
- 2 - 15.10.123.39 1.000" x .750" x  
3.335" Sleeve POS. 3
- 4 - 15.05.09.39 7/16-14 x 4" Bolt
- 2 - 15.05.10.39 7/16-14 x 6-1/2" Bolt
- 6 - 15.07.02.40 7/16-14 Lock Nut

## CORE POSITION #1

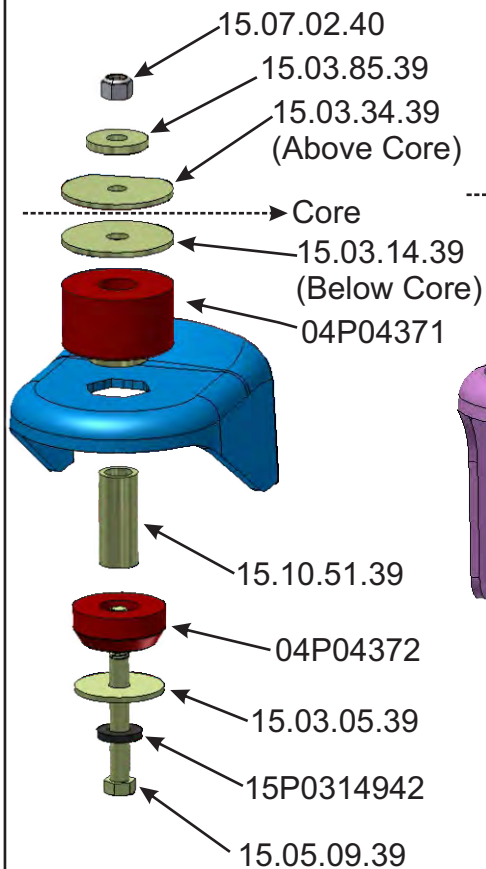

## POSITION #2

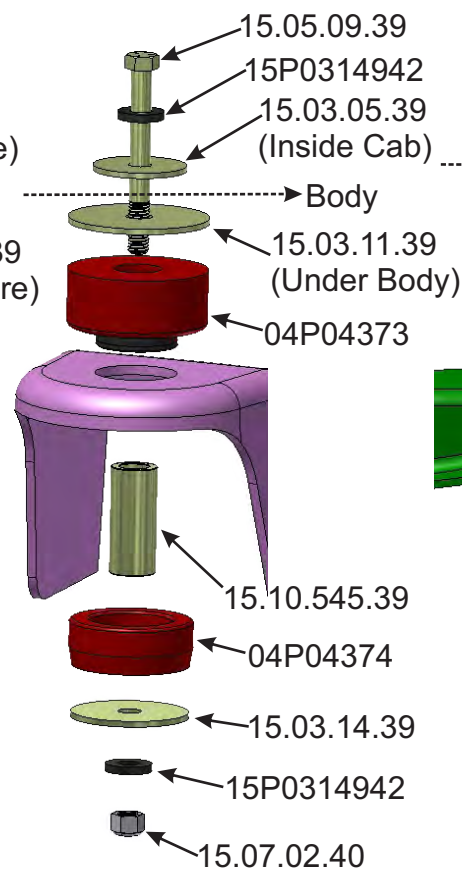

## POSITION #3

