

# Set # 5-4101 & # 5-4102



## Removal

It is recommended that a factory service manual be purchased prior to performing any work on your car or truck.

**Note:** When disassembling, note the quantity and positions of any shims that may have been inserted for body alignment. These shims will have to be reused to insure proper body alignment.

**Remember:** Only raise body high enough to remove & replace mounts. Always watch the fan shroud for sufficient clearance when raising the body. When jacking the body use a long enough 2X4 or 4X4 for maximum support. Never put jack directly on body panels.

Install mounts one side at a time with bolts on other side loosened only.

Retorque to factory specs.

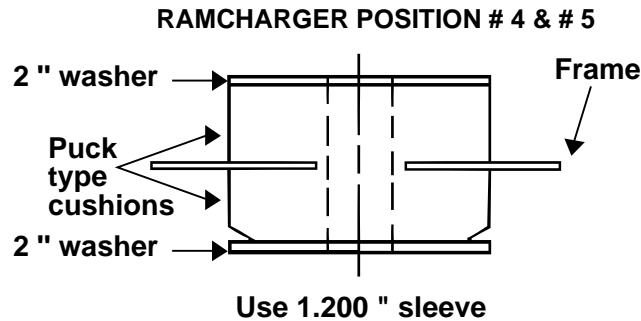
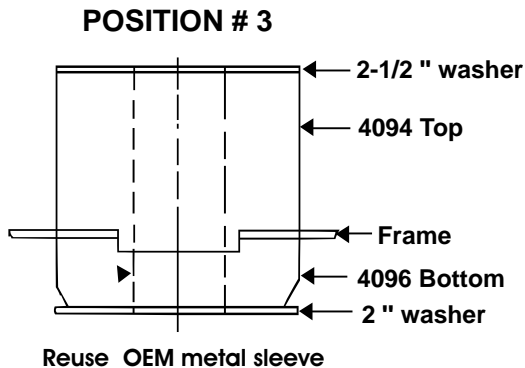
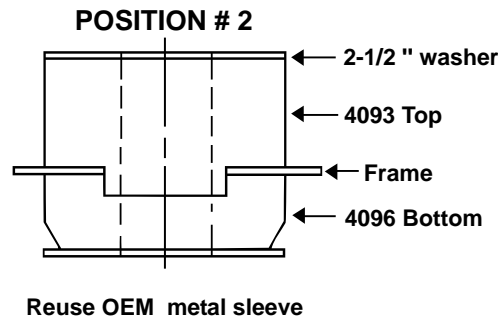
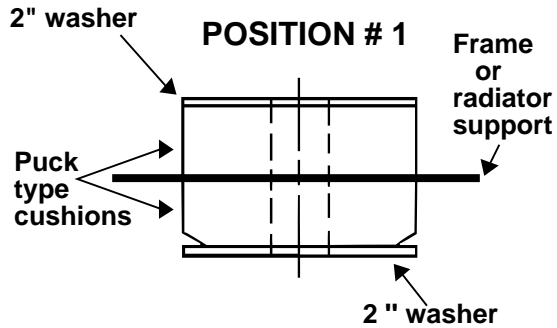
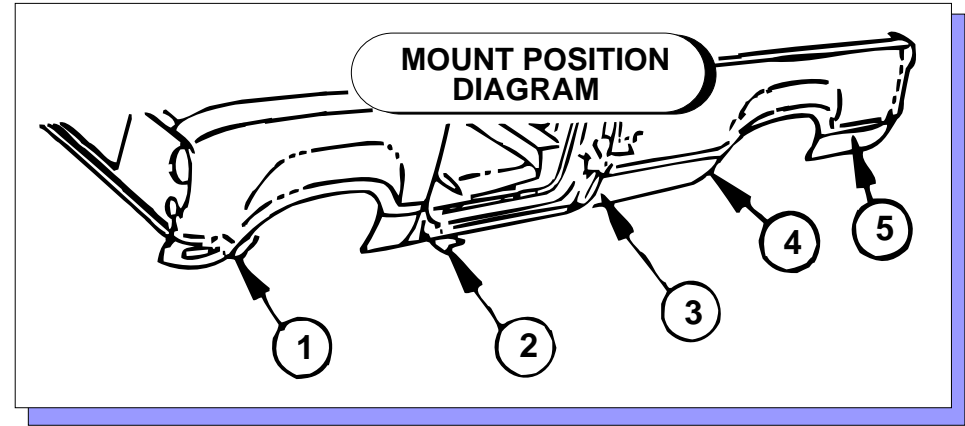

Typical style 1978-1985 P/U and all Ramchargers

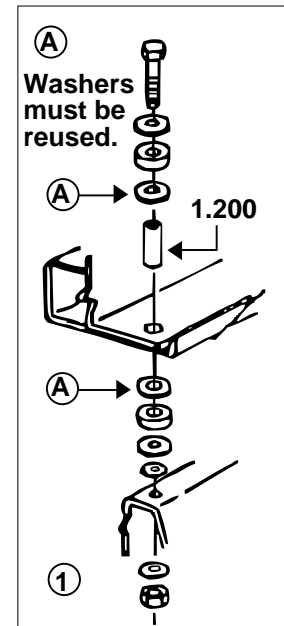

1st Style

Typical style 1972-1977 P/U and 1978-1981 Diesel P/U only

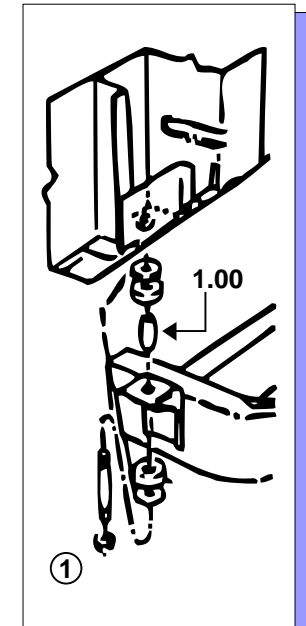

2nd Style

Note: On mount position # 3 when shoulder bolt installs from bottom up. Original 2" washers must be reused at the bottom. Also 2-1/2" washer with 1/2" I.D. will now be used at the top. (2-1/2" washer with 3/4" I.D. is not used)