

# Installation Instructions for Set # 8-3115



**Step #1** Remove front upper control arm from vehicle.

## Front upper control arm

**Step #2** Remove bushing and inner metal sleeve from the control arm. **Caution:** Do Not remove or damage the outer metal shell. We have found that using a slight amount of heat to break the bond between the rubber and shell will help ease removal. **Important!** Press the shells into the control arm so that there is **no gap** between the shell and the control arm. (diagram B) **Caution:** Always work in a well ventilated room and use the proper protective gear.

**Step #3** Clean out the inside of the shells and apply grease. Grease all sides of the bushing that contact metal. Install as shown in the diagram below. (diagram A)

**Step #4** Tighten all fasteners to factory specifications.

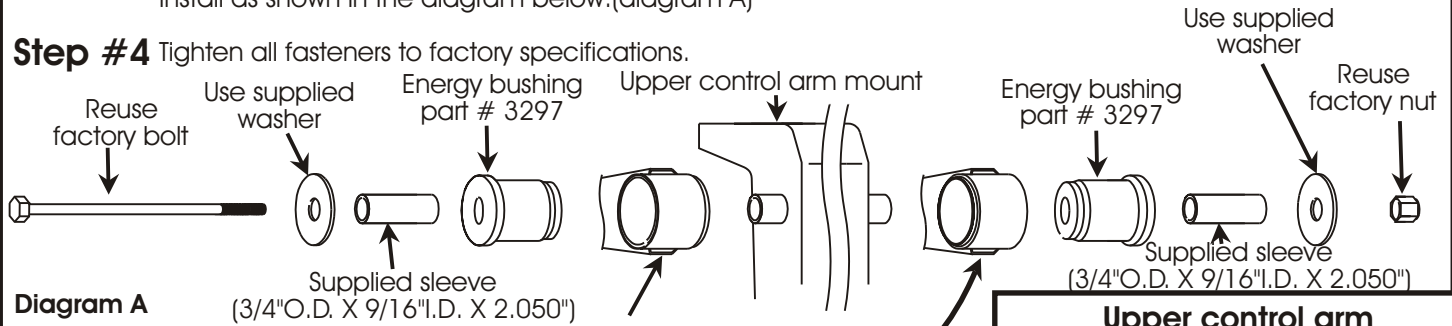
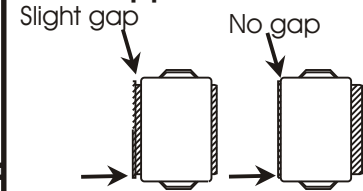

Diagram A

Remove bushing and inner metal sleeve from the control arm. **Caution:** Do Not remove or damage the outer metal shell. **Important!** Press the shells into the control arm so that there is **no gap** between the shell and the control arm. (diagram B)

## Upper control arm



Press bushing outer metal shell into the control arm. There should be no gap between the shell and the control arm.

Diagram B

## Front lower control arm

**Step #1**

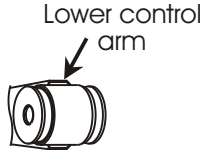

Marking the alignment cams of their location before removing the arm will help with alignment afterwards. Remove control arm from vehicle. This is a view of the stock original bushing including outer

**Step #2**

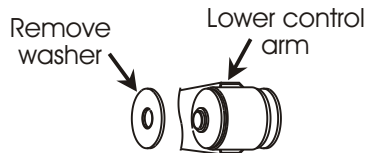

Remove one washer per bushing. The washers are pressed onto the sleeve and will need to be pressed off. We have found that careful use of a pickle fork or a blunt nosed punch seems to work best. **Caution:** Do not bend or damage this washer. You will reuse both the washers and the sleeves.

**Step #3**

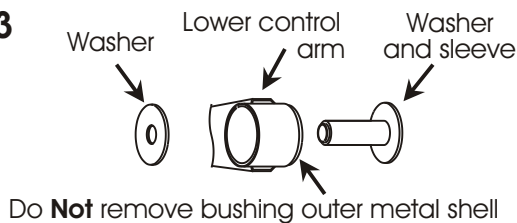

Remove the sleeve and rubber from the outer metal shell in the control arm. Do not remove or damage the bushing outer metal shell. Remove the center sleeve and attached washer from the bushing. We have found that using a slight amount of heat to break the bond between the rubber and sleeve and/or shell will help ease removal. **Caution:** Always work in a well ventilated room and use the proper protective gear.

**Step #4**

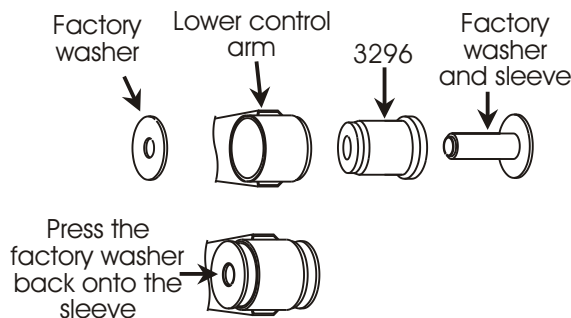

Clean all remaining rubber out of the control arm and off of the inner metal sleeve. Grease the inner metal sleeve and the I.D. of the bushing. Install the sleeve and attached washer into the bushing. Grease all remaining surfaces that contact metal and install the bushing and sleeve assembly into the control arm. Press the loose washer onto the sleeve and install the arm. Realign the alignment cams to the markings in step 1 and tighten all fasteners to factory specifications. Have your vehicle realigned as soon as possible.