

Installation Instructions

For set # 8.3132

Front Control Arm Bushing

1996-2002 Toyota 4Runner



It is recommended that if you are unfamiliar with this type of work that you refer to a qualified service center specializing in this type of work. It is also recommended that if you choose to do this work yourself that a factory service manual be obtained for the proper procedures pertaining to removal, replacement and proper torque specifications for your vehicle. This instruction set is intended as a guideline for the safe installation of Energy Suspension's polyurethane bushings, once you have removed the factory components from your vehicle. Wheel alignment is almost always disturbed when suspension components are removed or replaced. It is recommended that you have the alignment checked on your vehicle at a qualified alignment shop. Energy Suspension recommends that you read over all the installation instructions and check all P/N's and quantities in the parts list before you start. Prior to installation, make sure that your vehicle is in top mechanical condition and that there are no suspension or steering related problems. This part has been designed to work only with a vehicle that is in good state of repair. No matter how carefully we design our parts, this is one area we have no control over and cannot be held responsible.

THIS SET WILL NOT FIT AFTERMARKET REPLACEMENT RUBBER BUSHINGS. ONLY FACTORY ORIGINAL TOYOTA RUBBER BUSHINGS.

Parts list:

- 4 - 3297 (upper bushing)
- 4 - 3296 (lower bushing).
- 4 - 15P1070839
(sleeve .750" O.D. x .563" I.D. x 2.125" LG)
- 4 - 15.03.12.39
(washer 2" O.D. X 9/16" I.D. X 1/8" THK.)
- 1 - 17P17661 (instructions)

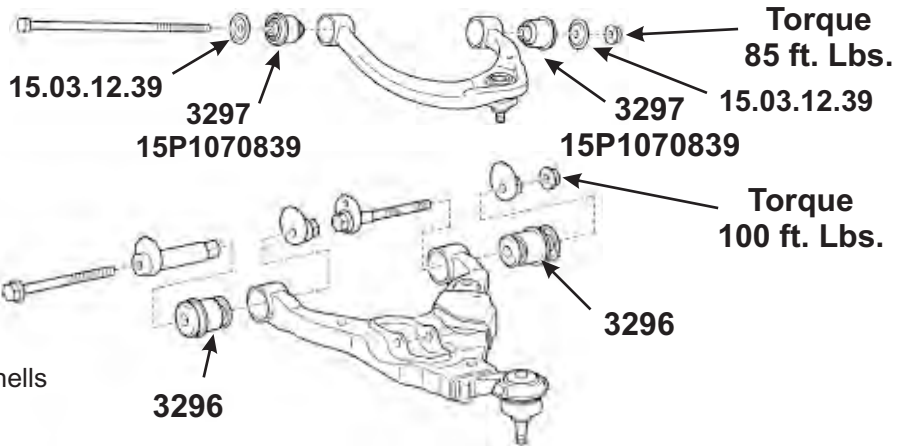

FOOT NOTES:

- (24) Uppers must reuse existing outer shells
- (23) Front lowers must reuse existing outer shells
- (73) Lowers must reuse all metal parts

Do this before loosening or removing anything.

Lower Control Arm

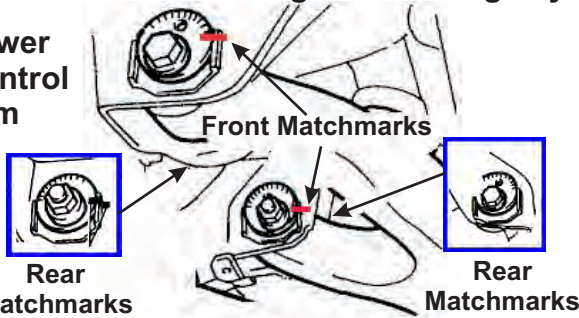

Be sure to place matchmarks on the front and rear adjusting cams before you start. You will need to use these matchmarks to reinstall the lower control arms back in the same position after the new polyurethane bushings are installed. Torque to 100 ft-lbs.

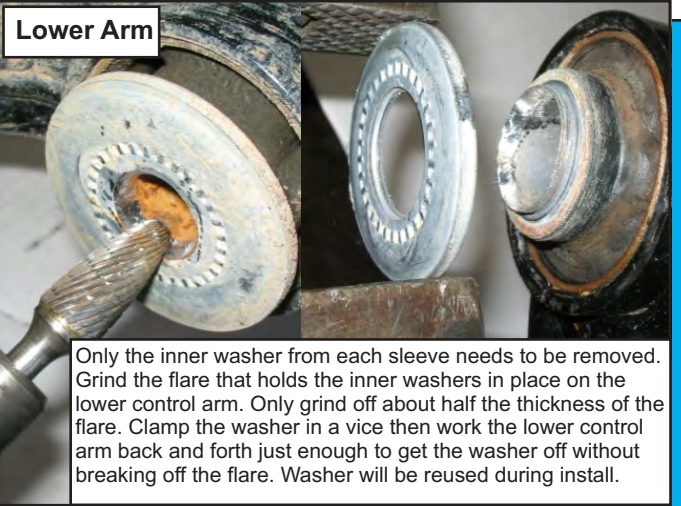

Only the inner washer from each sleeve needs to be removed. Grind the flare that holds the inner washers in place on the lower control arm. Only grind off about half the thickness of the flare. Clamp the washer in a vice then work the lower control arm back and forth just enough to get the washer off without breaking off the flare. Washer will be reused during install.



Do not remove the factory metal shells from the lower control arms, they must be reused. The inner metal sleeves and washers on the lower control arm must also be reused. To remove the old rubber from the factory shells and inner sleeves, first apply light heat from a torch evenly to inside of sleeves until bond is broken and use pliers to pull sleeve from rubber. Next apply light heat evenly around the outside of the control arm outer metal shell, just enough to break the bond with the rubber. When you see light smoke coming from the sides of the bushing the bond should be broken. **At no time should there be any flames coming from the rubber.** If there are any flames, you need to back off with the heat. Just push the old rubber and inner metal sleeve out. Let the outer metal shells and sleeves cool off before cleaning. Use a wire brush to remove any remaining old rubber. File off any sharp edges that will contact the new polyurethane bushings.

Installation instructions

For set # 8.3132

Front Control Arm Bushing 1996-2002 Toyota 4Runner

ENERGY
SUSPENSION 

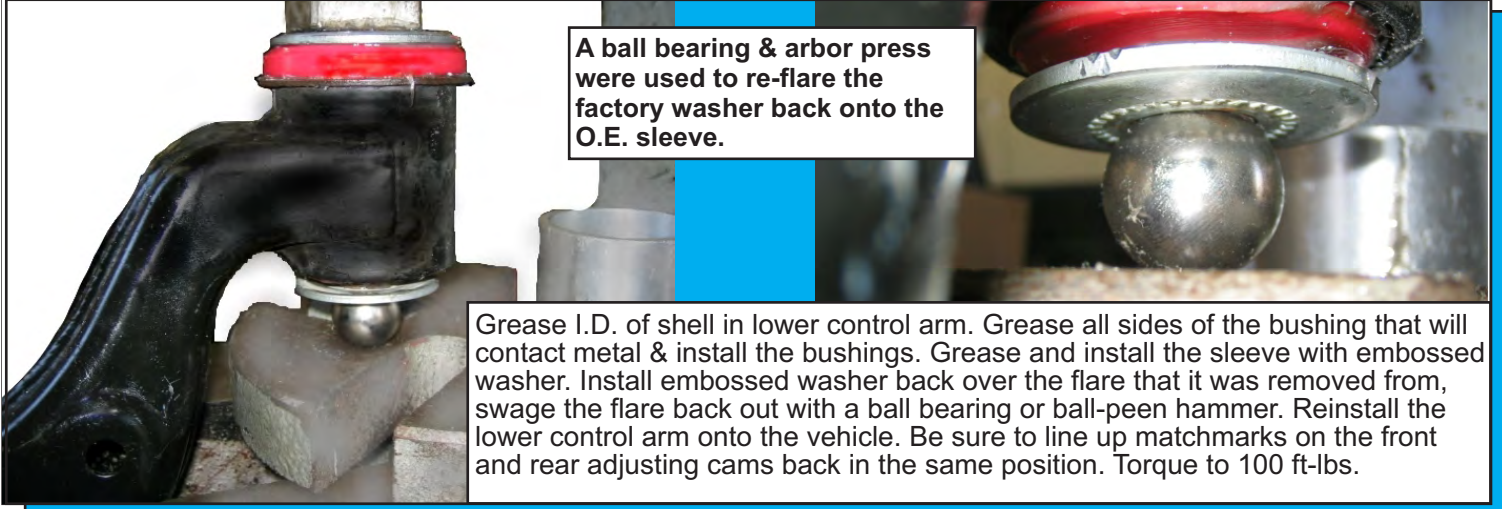

A ball bearing & arbor press were used to re-flare the factory washer back onto the O.E. sleeve.

Grease I.D. of shell in lower control arm. Grease all sides of the bushing that will contact metal & install the bushings. Grease and install the sleeve with embossed washer. Install embossed washer back over the flare that it was removed from, swage the flare back out with a ball bearing or ball-peen hammer. Reinstall the lower control arm onto the vehicle. Be sure to line up matchmarks on the front and rear adjusting cams back in the same position. Torque to 100 ft-lbs.

Upper arm



Do not remove the factory metal shells from the upper control arms, they must be reused. New inner metal sleeves are supplied for the upper control arms. To remove the old rubber and inner sleeves from the factory shells, apply light heat evenly around the outside of the control arm, just enough to break the bond with the rubber. When you see light smoke coming from the sides of the bushing the bond should be broken. **At no time should there be any flames coming from the rubber.** If there are any flames, you need to back off with the heat. Push the old rubber and inner metal sleeve out. Let the control arm and outer metal shells cool off before cleaning.



Use a wire brush to remove any remaining old rubber. File off any sharp edges that will contact the new polyurethane bushings. Apply grease to all metal parts that contact the polyurethane bushings and press the new bushing and sleeve into the control arms. Reinstall control arms back onto vehicle. Apply thread locking compound to upper control arm through-bolt, then torque to 85 ft-lbs. Check that all nuts and bolts that were previously removed for the new polyurethane bushing install have been torqued to factory specs. Replace all removed cotter pins with new cotter pins. After installation is complete, Energy Suspension recommends you have the alignment checked and set to factory specs by a certified technician after the work has been completed on the vehicle.