

## Instructions for Set # 8-4103

### Removal

**Spray all nuts to be removed generously with your favorite rust buster.**

1. Loosen all body mounting bolts, but only remove one side at a time. Some mounts are accessed from the inside of the cab.
2. The front bumper must be removed before raising the body.
3. Install the new body mounts one side at a time with the bolts on the other side loosened only. (see diagram for assembly sequence)
4. Retorque to factory specs.

**Note:** When disassembling, note the quantity and positions of any shims that may have been inserted for body alignment. These shims will have to be reused to insure proper body alignment.

**Important:** Only raise body high enough to remove & replace mounts. Always watch the fan shroud for sufficient clearance when raising the body. When jacking the body use a long enough 2X4 or 4X4 for maximum support. Never put jack pad directly on body panels.

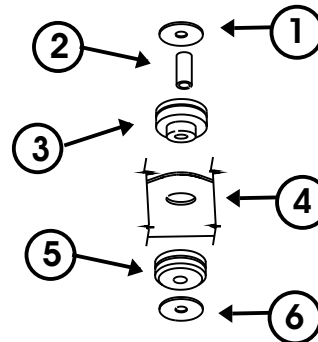
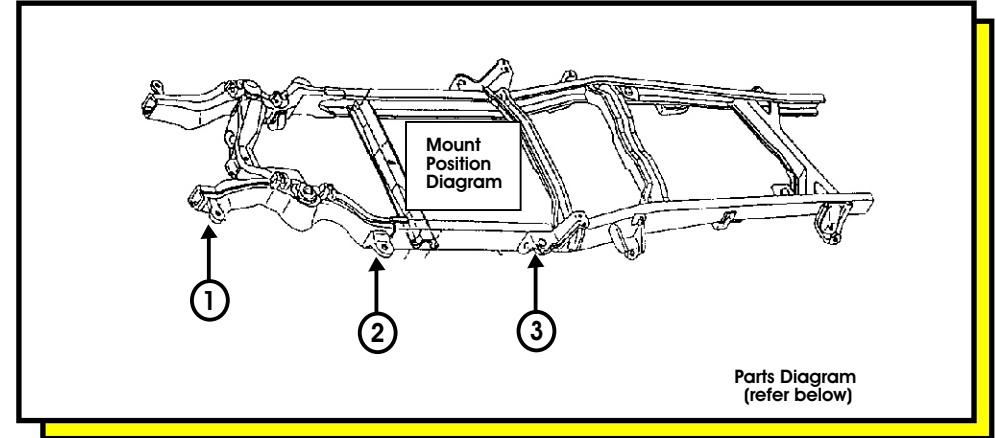

#### Position # 1

1. Supplied washer (2" O.D.)
2. Supplied sleeve (5/8"O.D. x 7/16"l.D. x 1.640")
3. Polyurethane bushing #4138
4. Frame perch
5. Polyurethane bushing #4139
6. Supplied washer (1-3/4"O.D. x 7/16"l.D. )

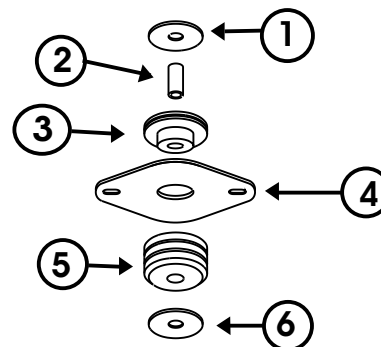

#### Position # 2 and # 3

1. Supplied washer (2 1/2" O.D.)
2. Supplied sleeve (3/4"O.D. x 1/2"l.D. x 1.900")
3. Polyurethane bushing #4136
4. Supplied adapter plate mounts on top of frame perch. Reuse factory bolts.
5. Polyurethane bushing #4137
6. Must reuse factory washer