

# Installation instructions

For set # 4.3157

98-11 FORD RANGER 2WD  
& 4WD WITH TORSION BARS

**ENERGY**  
**SUSPENSION** 

## Parts list:

- 4 - 3384 (upper C.A.B.).
- 2 - 3383 (lower C.A.B. front position).
- 2 - 3382 (lower C.A.B. rear position).
- 4 - 15.10.424.39 (sleeve .875"O.D. x .625" I.D. x 3.275"LG).
- 2 - 9.11114 (grease).

## UPPER CONTROL ARM

DO NOT REMOVE  
O.E. SHELLS  
MUST REUSE

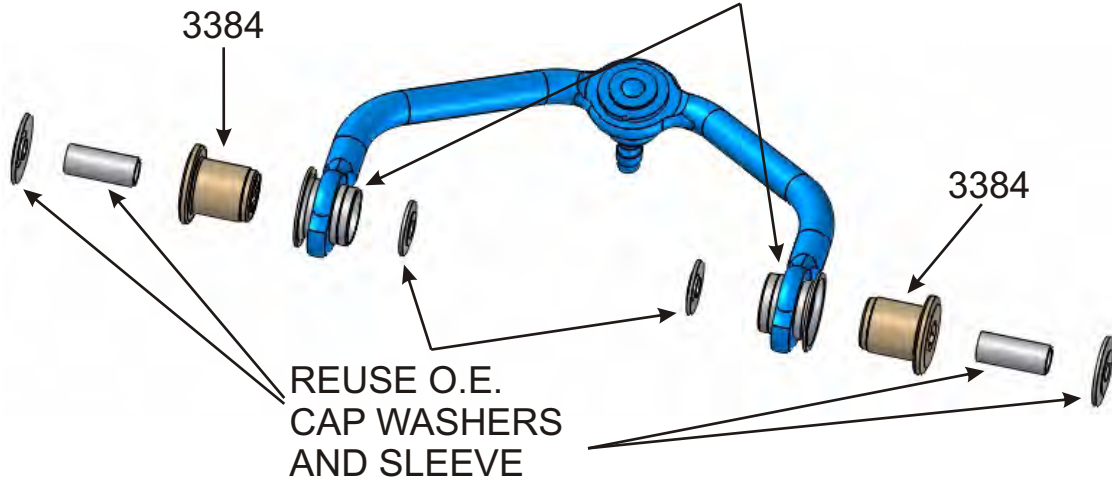

DO NOT REMOVE OUTER METAL SHELL FROM UPPER CONTROL ARM.



Rubber bushing is not bonded to outer metal shell. Use an arbor press and spray lube to push the rubber bushing out of the shell. Make sure inside surface of shell are free of all old bushing material and sharp edges.



# Installation instructions

For set # 4.3157

98-11 FORD RANGER 2WD  
& 4WD WITH TORSION BARS

**ENERGY**  
**SUSPENSION** 



Inner sleeve is bonded with the old rubber bushing. To remove the old rubber bushing from the sleeve, clamp the sleeve in a vice and using a utility knife, slice the bushing longways away from yourself. Clamp the bushing with vicegrips pulling the rubber back and slice as close to the sleeve as possible. Rotate the sleeve in the vice until you get all the way around. Clean as much rubber off the sleeve until smooth.

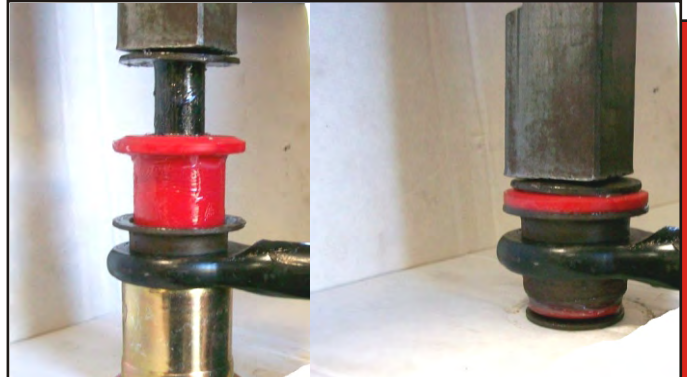

Coat urethane bushing, sleeve and shell I.D. with supplied grease. (all surfaces of bushings that contact metal). Inner sleeve and cap washer must be reused. Press the polyurethane, sleeve and big cap washer into the shell, then press on the small cap washer. The lower control arm bushings will be similar to the upper with the removal of the old rubber bushings and installation of the new polyurethane bushings.

## Lower control arms

**Note:** Do not remove O.E. Outer Shells from lower control arms.

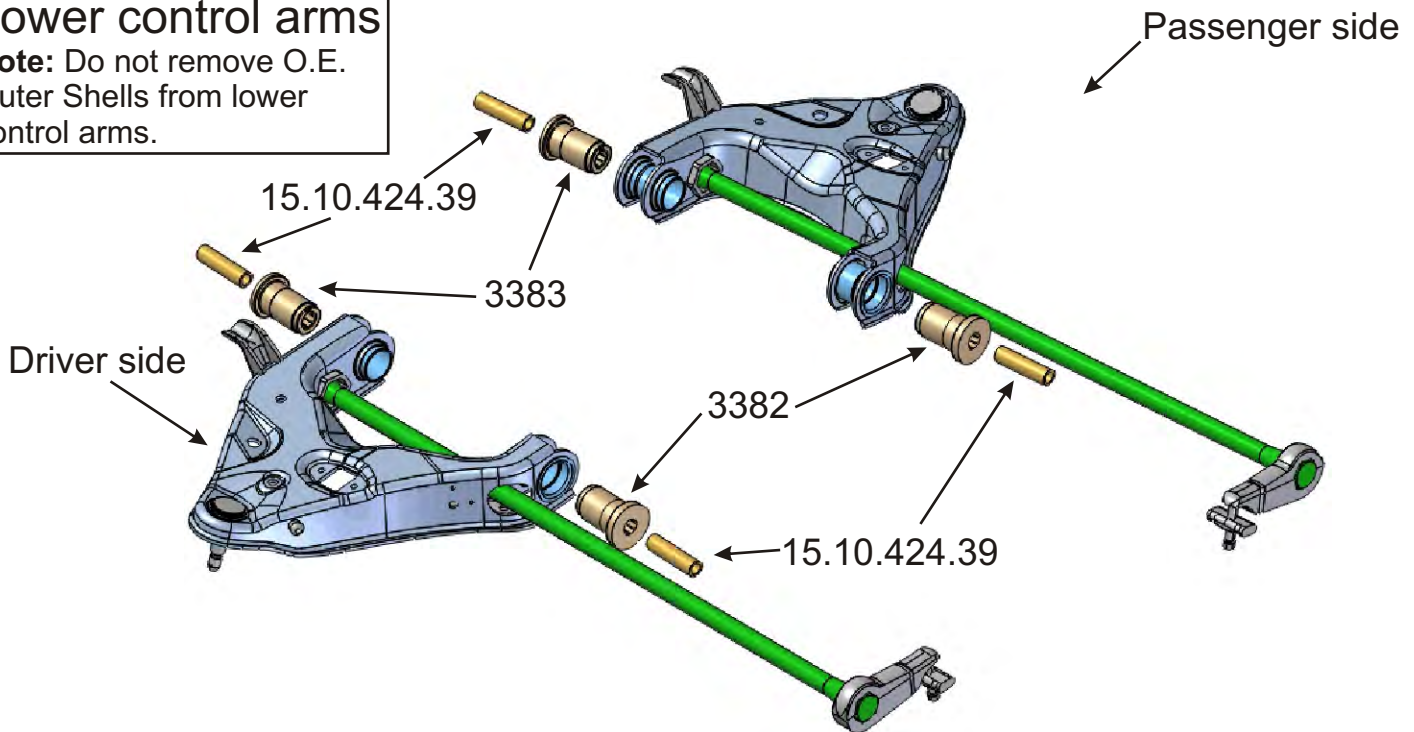

Bushing removal on the lower control arms will be similar to the upper control arms. Remove cap washers from the passenger rear position. Inner sleeve is not bonded to the rubber. With an arbor press and spray lube, press out the inner sleeve first to relieve the load from the rubber bushing. Use a lot of lube to help press out rubber bushing from shell. Install the new polyurethane bushings the same way as the upper control arm. Have the vehicle's alignment checked by a certified technician. The alignment must be within factory specifications.