



EQUIPMENT SUPPLY COMPANY



INSTRUCTION MANUAL

CYCLONE X-SERIES BEAD SEATING TANK

ESCO #20390—5 GALLON

ESCO #20391—10 GALLON



COPYRIGHT © 2019 EQUIPMENT SUPPLY CO., ALL RIGHTS RESERVED

Thank you for choosing ESCO tire service tools and equipment. We suggest you read this instruction manual thoroughly before using the product. Save this instruction manual for future use.

TABLE OF CONTENTS

- Introduction.....2
- Specifications.....2
- General Safety Rules.....3
- Operating Instructions.....4
- Parts Breakdown 5
- Warranty..... 6
- Parts and Repair Service..... 7

INTRODUCTION

The Cyclone X-Series Bead Seating Tank offers two models for small and medium applications. Both models are equipped with robust air tanks, casted out of steel and ASME certified. The Cyclone X-Series Bead Seaters supply a hassle-free, simple solution to seat the beads on equipment tires ranging from golf carts up to heavy duty and construction application. The Cyclone X-Series 5-gallon Bead Seating Tank is recommended for small and passenger tire application. The Cyclone X-Series 10-gallon Bead Seating Tank is recommended for most commercial tire sizes, skid steers and some tractor tires.

SPECIFICATIONS

MODEL NO.	TANK	OPERATING PRESSURE	WEIGHT	DIMENSIONS
20390	5 GAL	40-155 PSI	27.5 lbs	19" (482.6 mm) x16" (152.4 mm)x
20391	10 GAL	40-155 PSI	29.7 lbs (13.5 kg)	23" (584.2 mm) x 17" (431.8 mm) x

GENERAL SAFETY RULES

WARNING

- Read and understand all instructions. Failure to comply could result in death, bodily injury and/or damage to equipment.
- Do not allow children or untrained individuals to use this product.
- Always wear ANSI and OSHA standard Personal Protective Equipment when using this product. Not wearing eye wear, non-slip shoes or hearing protection may result in injury.
- Do not modify or use non-factory authorized parts on this product.
- Do not inflator or over flate the tire.
- Keep bystanders 20 feet away when tank is charged.
- Do not use this product for any other purpose than what it is designed for.
- Do not store or transport charged bead seating tanks. Discharge the air tank when it is not in use.
- Always follow OSHA 1910.77 standard* while using this product.
- Always visually inspect the product before use for damage. Do not use product if damaged, altered, or in poor condition.



EYE PROTECTION
MUST BE WORN



HEARING PROTECTION
MUST BE WORN



RESTRAINING DEVICE
MUST BE USED DURING
DE/INFLATION

*OSHA 1910.177 standard

1910.177(d)(1)

The employer shall furnish a restraining device for inflating tires on multi-piece wheels.

1910.177(d)(2)

The employer shall provide a restraining device or barrier for inflating tires on single piece wheels unless the rim wheel will be bolted onto a vehicle during inflation.

1910.177(d)(3)

Restraining devices and barriers shall comply with the following requirements:

1910.177(d)(3)(i)

Each restraining device or barrier shall have the capacity to withstand the maximum force that would be transferred to it during a rim wheel separation occurring at 150 percent of the maximum tire specification pressure for the type of rim wheel being serviced.

1910.177(d)(3)(ii)

Restraining devices and barriers shall be capable of preventing the rim wheel components from being thrown outside or beyond the device or barrier for any rim wheel positioned within or behind the device;

1910.177(d)(3)(iii)

Restraining devices and barriers shall be visually inspected prior to each day's use and after any separation of the rim wheel components or sudden release of contained air. Any restraining device or barrier exhibiting damage such as the following defects shall be immediately removed from service.

OPERATING INSTRUCTIONS

1. Always wear eyewear, hearing protection and the proper footwear while operating bead seating tank.
2. Keep work area clear.
3. Lay mounted tire flat on ground or stand (optional) with wide flange up (inflating stem facing down) place stand under rim near inflating stem.
4. Attached self holding chuck from air supply to inflating stem on rim.
5. Hold bead seater at an approximately 45 degree angle (shown below) from floor with guide on top of rim.
6. Hold handle tight and quickly open discharge valve.
7. Operating pressure of unit is 40-155 PSI from compressed air supply. Fill bead seating tank to a minimum of 40 psi from air compressor. Increase pressure as necessary. The safety pop-off is set at 165 psi (11.3 bar)

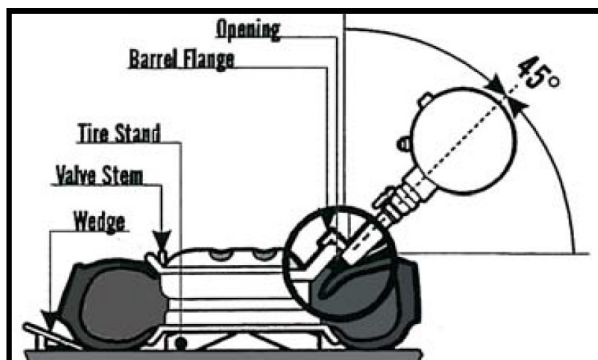

Figure 1.(above) When using on a horizontal Tire and wheel

RECOMMENDED PRESSURE CHART	
Tire Type	Pressure
ATV	40 PSI / 2.75 BAR
Passenger Car Radial Tire	60 PSI / 4.15 BAR
LT/SUV	80 PSI / 5.5 BAR
Truck and Bus Radial Tire	100 PSI / 6.9 BAR
OTR	120-155 PSI / 8.25-10.6 BAR

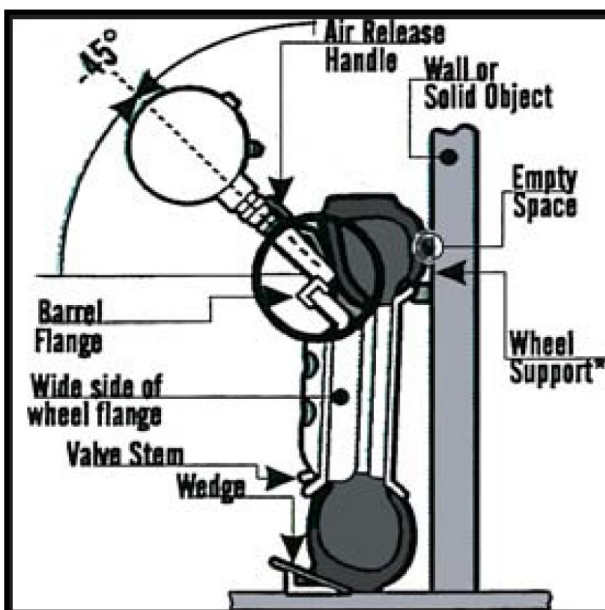
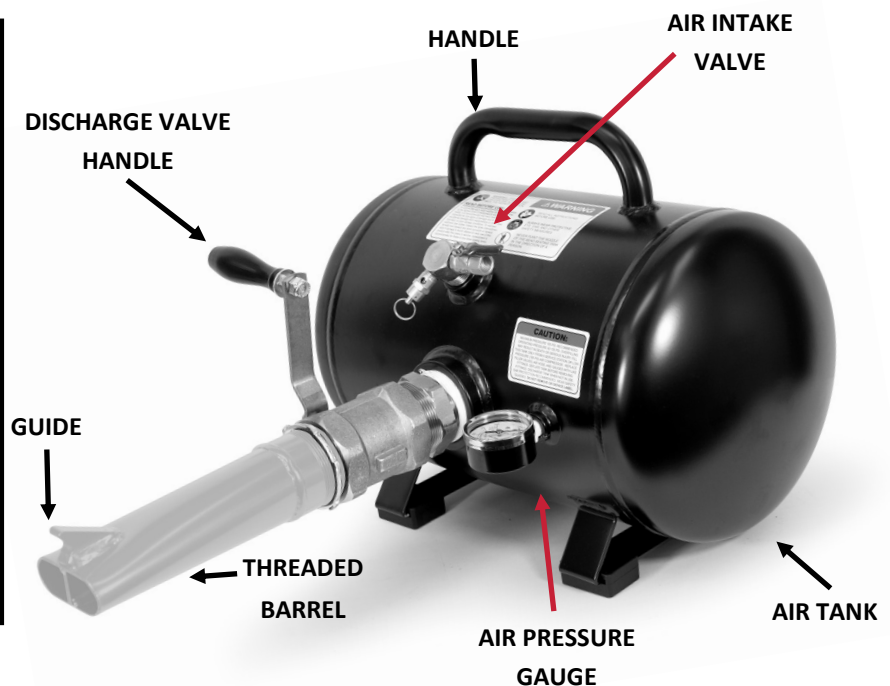

Figure 2. When using on vertical tire and wheel



Larger tires may be too difficult to seat, please make sure to use the proper sized Bead Seater for the Size Tire.

PARTS BREAKDOWN

FOR ALL CYCLONE X-SERIES MODELS:

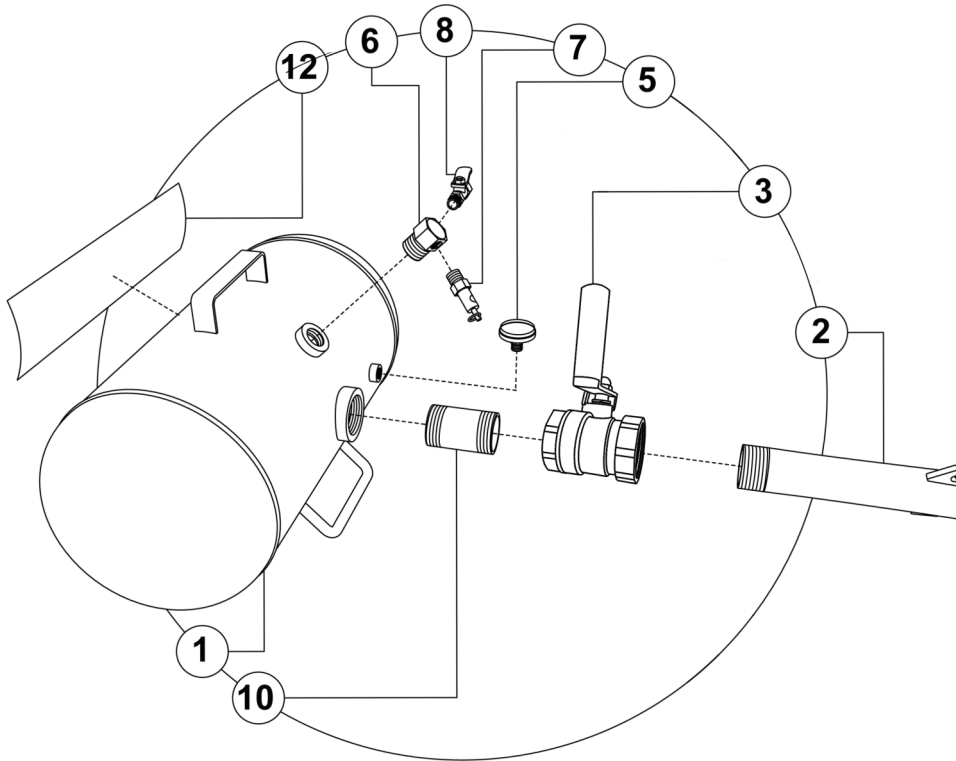

	DESCRIPTION	PART NUMBER
1.	AIR TANK	N/A
2.	THREADED FLARRED BARREL	20390-1
3.	2" BUTTERFLY VALVE (W/ HANDLE)	20390-4
5.	PRESSURE GAUGE	20390-5
6.	3/4" -1/4" BUSHING	2090-3
7.	PRESSURE RELEASE VALVE	20390-7
8.	FILLER VALVE	20390-8
10.	2" PIPE NIPPLE	N/A
12.	DECAL	N/A

PARTS AND REPAIR SERVICE

GUARANTEED 1-Day Turnaround Service.

Received by ESCO - Repaired in 24 Hours - Returned to you!

- ESCO will pick up product for repair/warranty at your location.
- ESCO will guarantee Repair/Service for 30 days.
- ESCO has rental tools available
- ESCO repairs IMT, FEC, Stellar, Blackhawk, OTC, Power Team, Ame Int., & Enerpac hydraulic pumps, bead breaker, and cylinders.
- Authorized ESCO Repair & Warranty Centers Located through the US & Canada. For more information contact your ESCO sales representative.

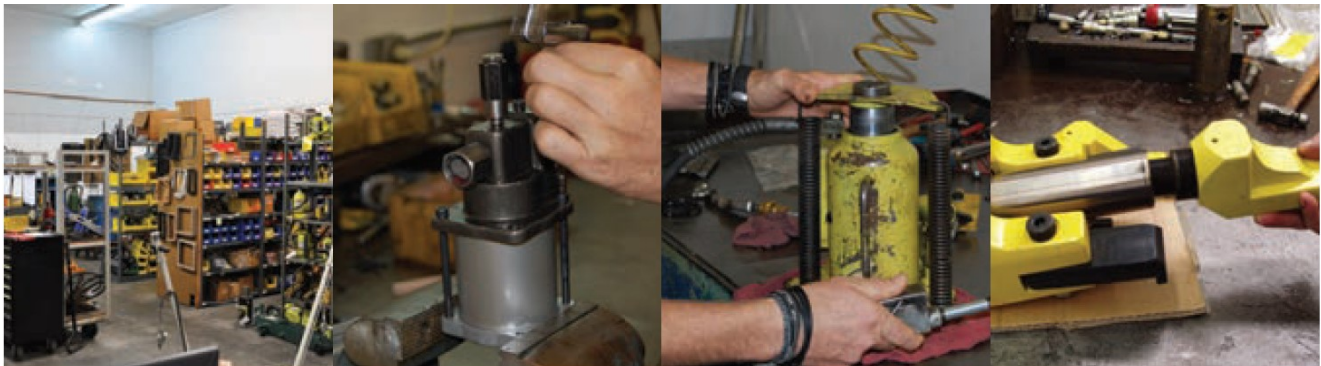

Prompt, reliable service after the sale is very important to ESCO. ESCO maintains an in-house repair facility in Brooksville, Florida. To insure that our customers have as little down-time as possible, we offer a 1 day turnaround service. Our factory repair service is equipped with all the tools and machinery needed to repair your equipment quickly and affordably. Our trained technicians are the best in the industry. Not only do we service our own products, but we also service our competitors' products.

In addition to ESCO's 30 years of providing quality repair service, ESCO has reached out and partnered with more than 50+ hydraulic repair facilities across the US & Canada, to deliver quality repair and timely return of products.

If you have a bead breaker, ram, or hydraulic pump that needs repair, ESCO fixes your product with factory parts and guarantees the repair. In addition to servicing ESCO brand products, we also re-pair CP, IMT, Elrick, Branick, Goodyear, FEC, AME Int., and Haltec lines of hydraulic bead breakers, rams, pumps, jacks, and many other hydraulic tire service equipment.